

Transistors

MPSA94

HIGH VOLTAGE TRANSISTOR

- High Collector-Emitter Voltage: $V_{CEO} = -400V$
- Low Collector-Emitter Saturation Voltage

ABSOLUTE MAXIMUM RATINGS ($T_A = 25^\circ C$)

Characteristic	Symbol	Rating	Unit
Collector Base Voltage	V_{CBO}	-400	V
Collector Emitter Voltage	V_{CEO}	-400	V
Emitter Base Voltage	V_{EBO}	-6	V
Collector Current	I_C	-300	mA
Collector Dissipation	P_C	625	mW
Junction Temperature	T_J	150	$^\circ C$
Storage Temperature	T_{STG}	-55 ~ 150	$^\circ C$

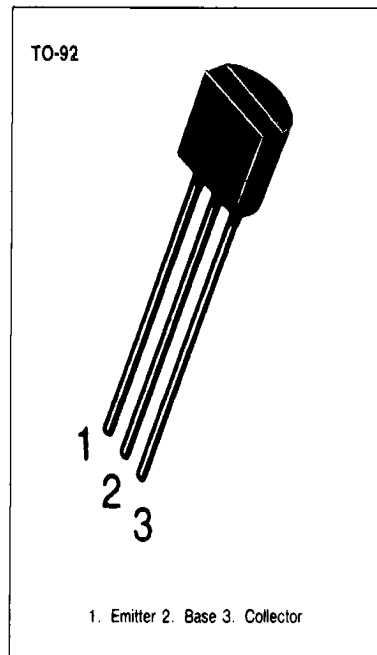

ELECTRICAL CHARACTERISTICS ($T_A = 25^\circ C$)

Characteristic	Symbol	Test Condition	Min	Typ	Max	Unit
Collector Base Breakdown Voltage	BV_{CBO}	$I_C = -100\mu A, I_E = 0$	-400			V
Collector Emitter Breakdown Voltage	BV_{CEO}	$I_C = -1mA, I_B = 0$	-400			V
Collector Emitter Breakdown Voltage	BV_{CES}	$I_C = -100\mu A, V_{BE} = 0$	-400			V
Emitter Base Breakdown Voltage	BV_{EBO}	$I_E = -10\mu A, I_C = 0$	-6			V
Collector Cutoff Current	I_{CBO}	$V_{CB} = -300V, V_E = 0$			-100	nA
Collector Cutoff Current	I_{CES}	$V_{CE} = -400V, V_{BE} = 0V$			-1	μA
Emitter Cutoff Current	I_{EBO}	$V_{BE} = -4V, I_C = 0$			-100	nA
DC Current Gain	h_{FE1}	$V_{CE} = -10V, I_C = -1mA$	40			
	h_{FE2}	$V_{CE} = -10V, I_C = -10mA$	50		300	
	h_{FE3}	$V_{CE} = -10V, I_C = -50mA$	45			
	h_{FE4}	$V_{CE} = -10V, I_C = -100mA$	40			
Collector Emitter Saturation Voltage	$V_{CE(sat)1}$	$I_C = -10mA, I_B = -1mA$			-500	mV
	$V_{CE(sat)2}$	$I_C = -50mA, I_B = -5mA$			-750	mV
Base Emitter Saturation Voltage	$V_{BE(sat)}$	$I_C = -10mA, I_B = -1mA$			-750	mV
Output Capacitance	C_{OB}	$V_{CB} = -20V, I_E = 0, f = 1MHz$		7		pF