

MS-211-3



MS-211-3

Ultraminiature Reed Sensor

Electrical Characteristics @ 25 °C

Contact form		A
Contact rating max.	W / VA	10
Switching voltage max.	VDC	150
	VAC	120
Switching current max.	A	0.5
Carry current max.	A	0.7
Breakdown voltage min.	VDC	200
Total resistance max. (initial)	mΩ	300
Insulation resistance min.	Ω	10 ⁹

Features

- > Small size
- > Customized types available
- > No power supply required

Magnetical Characteristics (of unmodified Reed Switch) @ 25 °C

Pull in range available	AT	10 - 20
Drop out min.	AT	3
Test coil	TC	010
Test equipment tolerance	± AT	2

Approvals

RoHS

REACH

Operating Characteristics (of unmodified Reed Switch) @ 25 °C

Switching frequency max.	Hz	600
Resonant frequency typ.	Hz	12000
Operate time max. (incl. bounce)	ms	0.3
Release time max.	ms	0.1

Environmental Characteristics

Operating temperature	°C	-20 to +85
Vibration (50-2000 Hz)	g	20
Shock (1/2 sin 11 ms)	g	100

Dimensions in mm

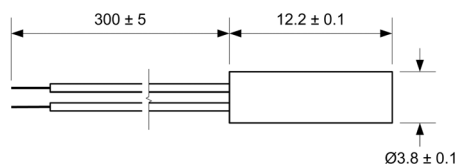

Ordering Information

Packing Unit	50 pcs
Weight per piece	1.52 g
Weight per package	85 g
Standard AT Ranges	

- 1 = 10 to 15 AT
- 2 = 15 to 20 AT

Ordering Example

MS-211-3-1 describes MS-211 with 10 to 15 AT

MS-211-3



MS-211-3

Ultraminiature Reed Sensor

Material Information		
	Material	Colour
Housing	ABS	black
Potting compound	Epoxy	black
Cable	UL 1061, AWG 26, 4 mm stripped and tinned	black

Test Procedure of final Reed Sensor

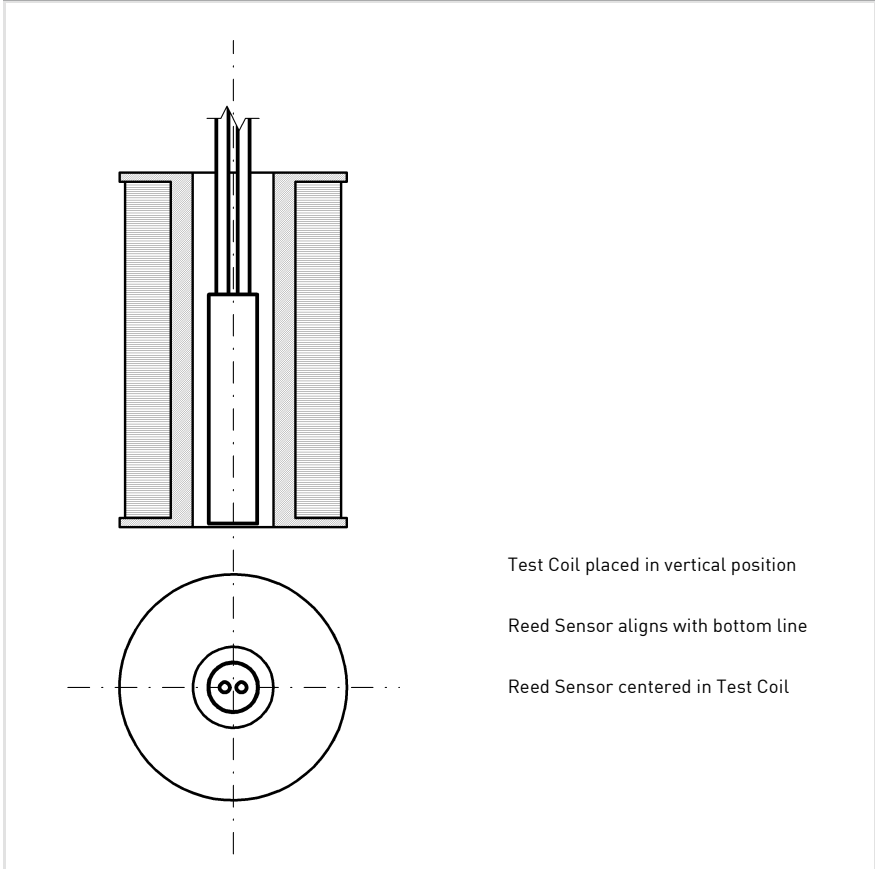

Test Parameters

Test coil	TC- 093
Test programs	
AT range	Test program
1 =	MS-211-3-1
2 =	MS-211-3-2

Remarks

When mounted onto ferromagnetic parts switching distance of MS-211-3 may reduce.
Electromagnetical influences and magnetic fields may change the switching behaviour of the sensor.