

MSM64P164

4-Bit Microcontroller with Built-in RC Oscillation Type A/D Converter and LCD Driver

GENERAL DESCRIPTION

The MSM64P164 is a one-time-programmable ROM-version product, which has one-time PROM (OTP) as internal program memory. On the other hand, the MSM64164C is a mask ROM-version product, which has mask ROM as internal program memory.

Unlike the mask ROM-version MSM64164C, which has a P-well CMOS structure, the MSM64P164 has been fabricated with the N-well CMOS-structured EEPROM process technology. Therefore, the MSM64P164 differs from the MSM64164C in the polarity of the power supply for LCD bias generation and 5 V interface, and in the external circuit structure.

Unlike the mask ROM-version product, the MSM64P164 cannot be supplied in the form of a chip. The MSM64P164 is an OTP-version product used to evaluate an application program.

The MSM64P164 has two operation modes, microcontroller operation mode and PROM mode. The microcontroller operation mode is used to operate the MSM64P164 like a mask ROM-version product and the PROM mode is used to program or read the PROM.

FEATURES

- Operating range
 - Operating frequencies : 32.768 kHz, 400 kHz
 - Operating voltage : 1.5 V/3.0 V selectable by mask option
 - Low supply current
 - Operating temperature : 0 to +65°C
- Memory space
 - Internal program memory : 4064 bytes
 - Internal data memory : 256 nibbles
- RC oscillation type A/D converter : 2 channels
 - Time dividing 2-channel method
 - Counter A : $1/(10^4 \times 8) \times 1$
 - Counter B : $1/2^{14} \times 1$
- Serial port : Synchronous 8-bit transfer
 - External clock/internal clock selectable
 - MSB first/LSB first selectable
- LCD driver : 34 outputs; duty ratio switchable by software
 - (1) At 1/4 duty and 1/3 bias : 120 segments (max)
 - (2) At 1/3 duty and 1/3 bias : 93 segments (max)
 - (3) At 1/2 duty and 1/2 bias : 64 segments (max)
- Buzzer driver : 1 output (4 output modes selectable)
- Capture circuit : 2 channels (256 Hz, 128 Hz, 64 Hz, 32 Hz)
- Watchdog timer
- I/O port
 - Input-output port : 3 ports \times 4 bits
 - Input port : 1 port \times 4 bits
 - Output port : 1 port \times 4 bits

- Interrupt sources
 - External interrupt : 2 sources
 - Internal interrupt : 8 sources
- Package:
 - 80-pin plastic QFP (QFP80-P-1420-0.80-BK) : (Product name : MSM64P164-xxxGS-BK)
xxx indicates a code number.

BLOCK DIAGRAM

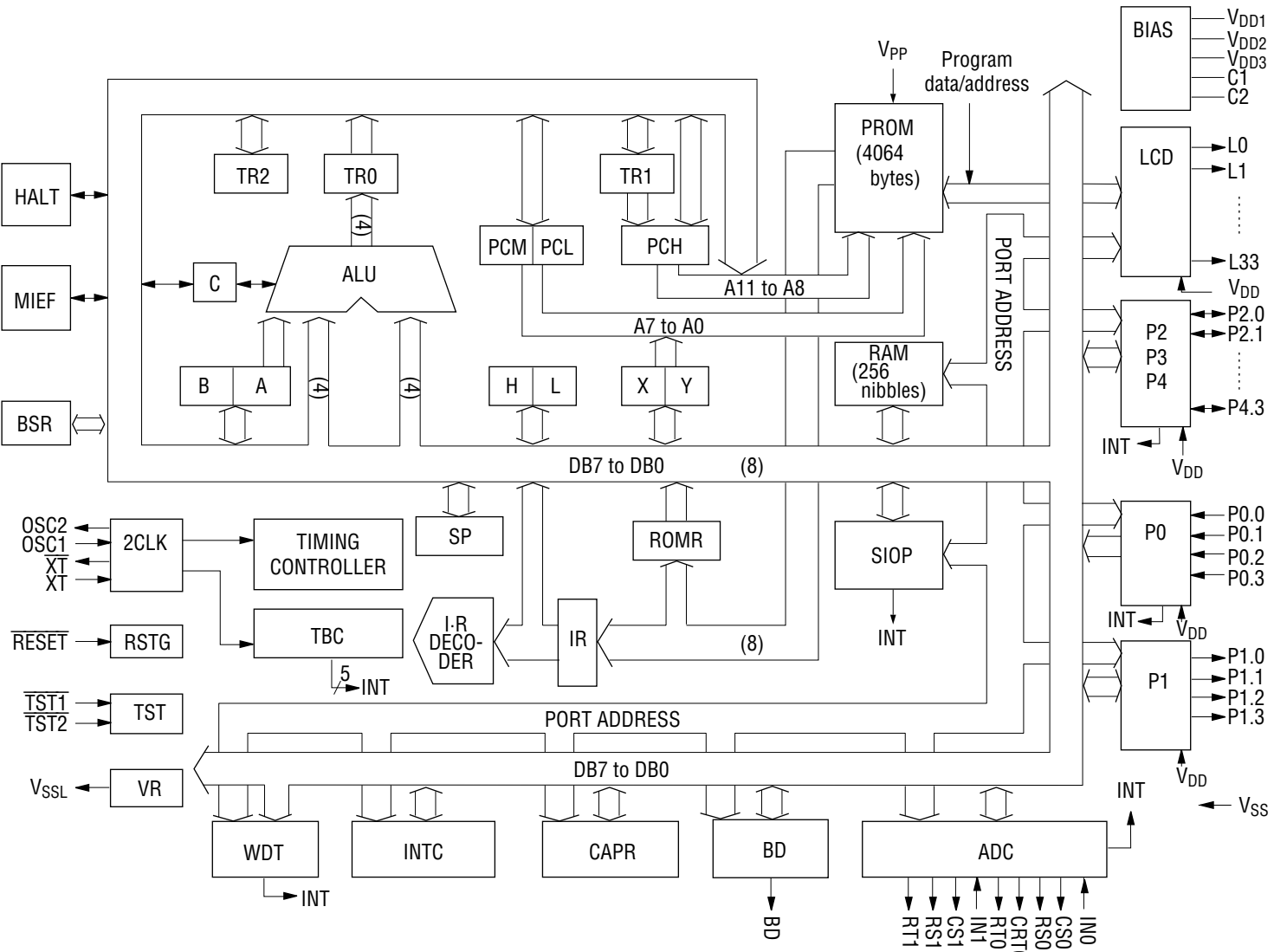

PIN CONFIGURATION (TOP VIEW)

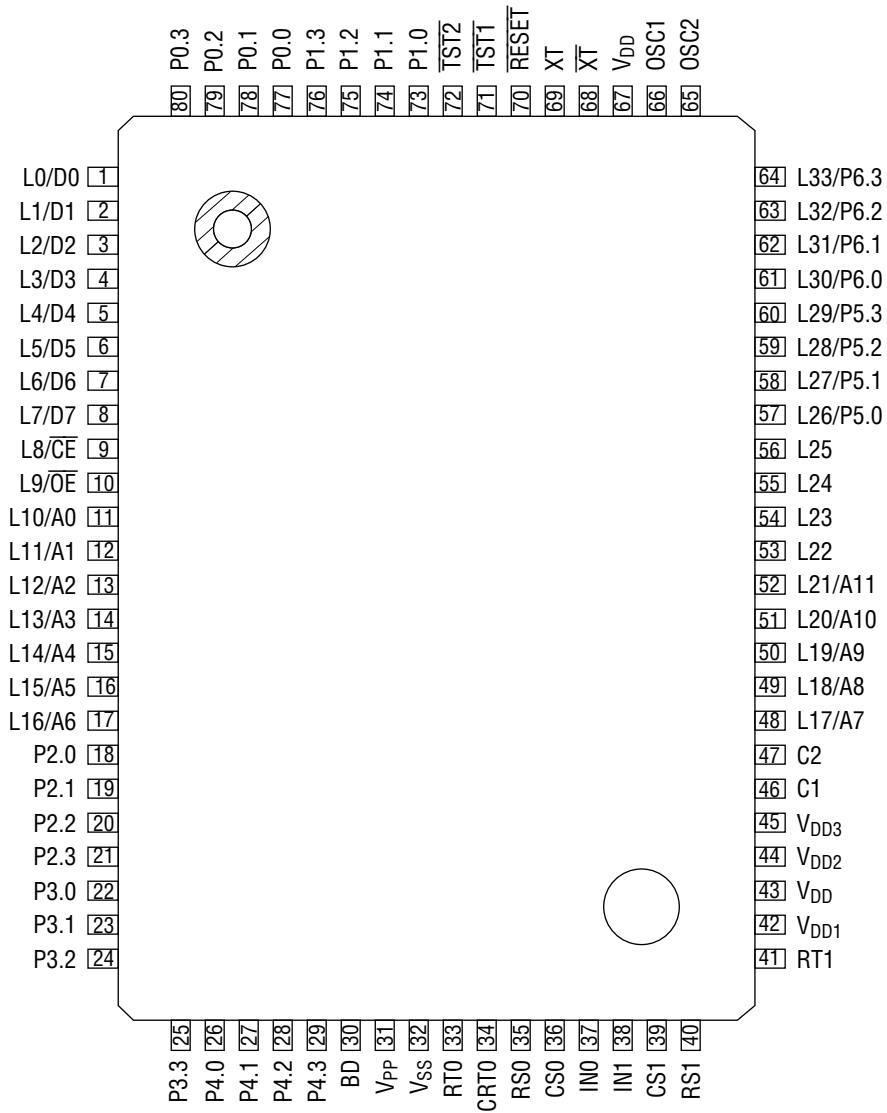

80-Pin Plastic QFP

Note: Because pin 32 and pin 67 are internally connected with each other, V_{DD} can be supplied from either pin 32 or pin 67.

PIN DESCRIPTIONS

Basic Functions

Function	Pin	Symbol	Type	Description	
Power Supply	32	V _{SS}	—	0 V power supply	
	42	V _{DD1}	—	Bias output for driving LCD (+1.5 V), or positive power supply at 1.5 V spec.	
	44	V _{DD2}	—	Bias output for driving LCD (+3.0 V), or positive power supply at 3.0 V spec.	
	45	V _{DD3}	—	Bias output for driving LCD (+4.5 V).	
	43	V _{DD}	—	Positive power supply for I/O port interface	
	31	V _{PP}	—	Positive power supply for writing to PROM (+12.5 V)	
	46,47	C1, C2	—	Pins for connecting a capacitor for generating LCD driving bias.	
Oscillation	69	XT	I	32.768 kHz crystal connection pins	
	68	\overline{XT}	O		
	66	OSC1	I	External 400 kHz oscillation resistor (R _{OS}) connection pins	
	65	OSC2	O		
Ports	73 to 76	P1.0 to P1.3	O	Output port (P1.0 : high current output)	
	77 to 80	P0.0 to P0.3	I	Input port	
	18 to 29	P2.0 to P4.3	I/O	Input-output ports	
	30	BD	O	Output pin for the buzzer driver	
A/D Converter	33	RT0	O	Resistance temperature sensor connection pin	RC oscillation pins for A/D converter (channel 0) (CROSC0)
	34	CRT0	O	Resistance/capacitance temperature sensor connection pin	
	35	RS0	O	Reference resistor connection pin	
	36	CS0	O	Reference capacitor connection pin	
	37	IN0	I	Input pin for RC oscillator circuit	
	41	RT1	O	Resistance temperature sensor connection pin	RC oscillation pins for A/D converter (channel 1) (CROSC1)
	40	RS1	O	Reference resistor connection pin	
	39	CS1	O	Reference capacitor connection pin	
38	IN1	I	Input pin for RC oscillator circuit		
Reset	70	\overline{RESET}	I	System reset input pin. Setting this pin to "L" level puts this device into a reset state. Then, setting this pin to "H" level starts executing an instruction from address 000H. This pin is internally pulled up to V _{DD} .	
Test	71	$\overline{TST1}$	I	Input pins for testing.	
	72	$\overline{TST2}$	I		
LCD Drivers	1 to 17, 48 to 56	L0 to L25	O	LCD driver pins	
	57 to 64	L26/P5.0 to L33/P6.3	O	LCD driver pins, or output ports by mask option	

Secondary Functions

Function	Pin	Symbol	Type	Description
External Interrupt	77	P0.0	I	Secondary functions of P0.0 to P0.3: Level-triggered external interrupt input pins. The change of input signal level causes an interrupt to occur.
	78	P0.1		
	79	P0.2		
	80	P0.3		
	18	P2.0	I	Secondary functions of P2.0 to P2.3, P3.0 to P3.3, and P4.0 to P4.3: Level-triggered external interrupt input pins. The change of input signal level causes an interrupt to occur.
	19	P2.1		
	20	P2.2		
	21	P2.3		
	22	P3.0		
	23	P3.1		
	24	P3.2		
	25	P3.3		
	26	P4.0		
	27	P4.1		
	28	P4.2		
29	P4.3			
Capture Trigger	77	P0.0	I	Secondary functions of P0.0 and P0.1: Capture circuit trigger input pins.
	78	P0.1		
Serial Port	25	P3.3	I	Secondary functions of P3.3: This pin is assigned the data input of a serial port (SIN).
	26	P4.0	O	Secondary functions of P4.0: This pin is assigned the data output of a serial port (SOUT).
	27	P4.1	O	Secondary functions of P4.1: This pin is assigned the ready output of a serial port (SPR).
	28	P4.2	I/O	Secondary functions of P4.2: This pin is assigned the clock I/O of a serial port (SCLK).
RC Oscillation Monitor	29	P4.3	O	Secondary functions of P4.3: This pin is a monitor output (MON) of an RC oscillation clock (OSCCLK) for an A/D converter and a 400 kHz RC oscillation clock for a system clock.

PROM-Related Pins

Function	Pin	Symbol	Type	Description
Program- ming	32, 67	V _{SS}	0	0 V power supply.
	42	V _{DD1} *	—	Positive power supply pin (+5 V supplied).
	44	V _{DD2} *	—	Positive power supply pin (+5 V supplied).
	31	V _{PP}	—	PROM write power supply (+12.5 V supplied).
	70	$\overline{\text{RESET}}$	I	PROM write setting pins: PROM mode is set by a "L" level input.
	71	$\overline{\text{TST1}}$		
	72	$\overline{\text{TST2}}$		
	1	L0/D0	I/O	Pins for writing and reading program data.
	2	L1/D1		
	3	L2/D2		
	4	L3/D3		
	5	L4/D4		
	6	L5/D5		
	7	L6/D6		
	8	L7/D7		
	9	L8/ $\overline{\text{CE}}$	I/O	PROM chip enable pin.
	10	L9/ $\overline{\text{OE}}$	I/O	PROM output enable signal.
	11	L10/A0	I	Program address input pins.
	12	L11/A1		
	13	L12/A2		
	14	L13/A3		
	15	L14/A4		
	16	L15/A5		
	17	L16/A6		
	48	L17/A7		
49	L18/A8			
50	L19/A9			
51	L20/A10			
52	L21/A11			
53	L22	I	Apply a "H" level to this pin.	

* When in PROM mode, supply a 5 V power to both V_{DD1} and V_{DD2}.

ABSOLUTE MAXIMUM RATINGS (1.5 V Spec.)(V_{SS} = 0 V)

Parameter	Symbol	Condition	Rating	Unit
Power Supply Voltage 1	V _{DD1}	Ta = 25°C	-0.3 to +2.0	V
Power Supply Voltage 2	V _{DD2}	Ta = 25°C	-0.3 to +4.0	V
Power Supply Voltage 3	V _{DD3}	Ta = 25°C	-0.3 to +5.5	V
Power Supply Voltage 4	V _{DD}	Ta = 25°C	-0.3 to +5.5	V
Input Voltage 1	V _{IN1}	V _{DD1} input, Ta = 25°C	-0.3 to V _{DD1} + 0.3	V
Input Voltage 2	V _{IN2}	V _{DD} input, Ta = 25°C	-0.3 to V _{DD} + 0.3	V
Output Voltage 1	V _{OUT1}	V _{DD1} output, Ta = 25°C	-0.3 to V _{DD1} + 0.3	V
Output Voltage 2	V _{OUT2}	V _{DD2} output, Ta = 25°C	-0.3 to V _{DD2} + 0.3	V
Output Voltage 3	V _{OUT3}	V _{DD3} output, Ta = 25°C	-0.3 to V _{DD3} + 0.3	V
Output Voltage 4	V _{OUT4}	V _{DD} output, Ta = 25°C	-0.3 to V _{DD} + 0.3	V
Storage Temperature	T _{STG}	—	-55 to +150	°C

RECOMMENDED OPERATING CONDITIONS (1.5 V Spec.)(V_{SS} = 0 V)

Parameter	Symbol	Condition	Range	Unit
Operating Temperature	T _{OP}	—	0 to +65	°C
Operating Voltage	V _{DD1}	—	1.4 to 1.7	V
	V _{DD}	—	V _{DD1} to 5.25	V
External 400 kHz RC Oscillator Resistance	R _{OS}	—	250 to 500	kΩ
Crystal Oscillation Frequency	f _{XT}	—	30 to 35	kHz

ELECTRICAL CHARACTERISTICS (1.5 V Spec.)**DC Characteristics**(V_{SS} = 0 V, V_{DD1} = V_{DD} = 1.5 V, T_a = 0 to +65°C unless otherwise specified)

Parameter	Symbol	Condition	Min.	Typ.	Max.	Unit	Measuring Circuit
V _{DD2} Voltage	V _{DD2}	C _a , C _b , C ₁₂ = 0.1 μF +100% -50%	2.8	3.0	3.2	V	1
V _{DD3} Voltage	V _{DD3}	C _a , C _b , C ₁₂ = 0.1 μF +100% -50%	4.3	4.5	4.7	V	
Crystal Oscillation Start Voltage	V _{STA}	Oscillation start time: within 5 seconds	1.47	—	—	V	
Crystal Oscillation Hold Voltage	V _{HOLD}	—	1.40	—	—	V	
Crystal Oscillation Stop Detection Time	T _{STOP}	—	0.1	—	1000	ms	
Internal Crystal Oscillator Capacitance	C _G	—	10	15	20	pF	
External Crystal Oscillator Capacitance	C _{GEX}	When external C _G used	10	—	30	pF	
Internal Crystal Oscillator Capacitance	C _D	—	10	15	20	pF	
Internal 400k RC Oscillator Capacitance	C _{OS}	—	8	12	16	pF	
400k RC Oscillation Frequency	f _{OSC}	External resistor R _{OS} = 300 kΩ V _{DD1} = 1.40 to 1.7 V	80	220	350	kHz	
POR Generation Voltage	V _{POR1}	When V _{DD1} is between V _{POR1} and 1.5 V	0	—	0.4	V	
POR Non-generation Voltage	V _{POR2}	No POR when V _{DD1} is between V _{POR2} and 1.5 V	1.4	—	1.5	V	

Notes: 1. "POR" denotes Power On Reset.

- "T_{STOP}" indicates that if the crystal oscillator stops over the value of T_{STOP}, the system reset occurs.

DC Characteristics (continued)

($V_{SS} = 0\text{ V}$, $V_{DD1} = V_{DD} = 1.5\text{ V}$, $T_a = 0\text{ to }+65^\circ\text{C}$ unless otherwise specified)

Parameter	Symbol	Condition	Min.	Typ.	Max.	Unit	Measuring Circuit
Supply Current 1	I_{DD1}	CPU in halt state (400k RC oscillation halt)	—	2.0	5.0	μA	1
Supply Current 2	I_{DD2}	CPU in operating state (400k RC oscillation halt)	—	50	80	μA	
Supply Current 3	I_{DD3}	CPU in operating state (400k RC oscillation in operation) $R_{OS} = 300\text{ k}\Omega$	—	90	180	μA	
Supply Current 4	I_{DD4}	Serial transfer, $f_{SCK} = 300\text{ kHz}$, CPU in operating state (400k RC oscillation halt)	—	60	100	μA	
Supply Current 5	I_{DD5}	CPU in halt state (400k RC oscillation halt), RC oscillator for	$RT0 = 10\text{ k}\Omega$	—	150	230	
		A/D converter is in operating state	$RT0 = 2\text{ k}\Omega$	—	600	900	μA

DC Characteristics (continued)

($V_{SS} = 0\text{ V}$, $V_{DD1} = V_{DD} = 1.5\text{ V}$, $V_{DD2} = 3.0\text{ V}$, $V_{DD3} = 4.5\text{ V}$,
 $T_a = 0\text{ to }+65^\circ\text{C}$ unless otherwise specified)

Parameter (Pin Name)	Symbol	Condition	Min.	Typ.	Max.	Unit	Measuring Circuit
Output Current 1 (P1.0)	I_{OH1}	$V_{OH1} = V_{DD} - 0.5\text{ V}$	-2.1	-0.7	-0.2	mA	2
	I_{OL1}	$V_{OL1} = 0.5\text{ V}$	1.0	3.0	9.0	mA	
	I_{OL1S}	$V_{DD} = 5\text{ V}$, $V_{OL1} = 0.5\text{ V}$	4.0	12	36	mA	
Output Current 2 (P1.1 to P1.3) (P2.0 to P2.3) (P3.0 to P3.3) (P4.0 to P4.3)	I_{OH2}	$V_{OH2} = V_{DD} - 0.5\text{ V}$	-2.1	-0.7	-0.2	mA	
	I_{OL2}	$V_{OL2} = 0.5\text{ V}$	0.2	0.7	2.1	mA	
	I_{OL2S}	$V_{DD} = 5\text{ V}$, $V_{OL2} = 0.5\text{ V}$	1.0	3.0	9.0	mA	
Output Current 3 (BD)	I_{OH3}	$V_{OH3} = V_{DD1} - 0.7\text{ V}$	-1.8	-0.6	-0.2	mA	
	I_{OL3}	$V_{OL3} = 0.7\text{ V}$	0.2	0.6	1.8	mA	
Output Current 4 (RT0, RT1, RS0, RS1, CRT0, CS0, CS1)	I_{OH4}	$V_{OH4} = V_{DD1} - 0.1\text{ V}$	-1.1	-0.6	-0.3	mA	
	I_{OL4}	$V_{OL4} = 0.1\text{ V}$	0.3	0.6	1.1	mA	
Output Current 5 (When L26 to L33 are configured as output ports)	I_{OH5}	$V_{OH5} = V_{DD} - 0.5\text{ V}$	-1.5	-0.5	-0.1	mA	
	I_{OL5}	$V_{OL5} = 0.5\text{ V}$	0.1	0.5	1.5	mA	
	I_{OL5S}	$V_{DD} = 5\text{ V}$, $V_{OL5S} = 0.5\text{ V}$	0.2	0.7	2.0	mA	
Output Current 6 (OSC2)	I_{OH6}	$V_{OH6} = V_{DD1} - 0.5\text{ V}$	-2.1	-0.7	-0.2	mA	
	I_{OL6}	$V_{OL6} = 0.5\text{ V}$	0.2	0.7	2.1	mA	
Output Current 7 (L0 to L33)	I_{OH7}	$V_{OH7} = V_{DD3} - 0.2\text{ V}$ (V_{DD3} level)	—	—	-4.0	μA	
	I_{OMH7}	$V_{OMH7} = V_{DD2} + 0.2\text{ V}$ (V_{DD2} level)	4.0	—	—	μA	
	I_{OMH7S}	$V_{OMH7S} = V_{DD2} - 0.2\text{ V}$ (V_{DD2} level)	—	—	-4.0	μA	
	I_{OML7}	$V_{OML7} = V_{DD1} + 0.2\text{ V}$ (V_{DD1} level)	4.0	—	—	μA	
	I_{OML7S}	$V_{OML7S} = V_{DD1} - 0.2\text{ V}$ (V_{DD1} level)	—	—	-4.0	μA	
	I_{OL7}	$V_{OL7} = V_{SS} + 0.2\text{ V}$ (V_{SS} level)	4.0	—	—	μA	
Output Leakage Current (P1.0 to P1.3) (P2.0 to P2.3) (P3.0 to P3.3) (P4.0 to P4.3) (RT0, RT1, RS0, RS1, CRT0, CS0, CS1)	I_{OOH}	$V_{OH} = V_{DD1}$	—	—	0.3	μA	
	I_{OOL}	$V_{OL} = V_{SS}$	-0.3	—	—	μA	

DC Characteristics (continued)

($V_{SS} = 0\text{ V}$, $V_{DD1} = V_{DD} = 1.5\text{ V}$, $V_{DD2} = 3.0\text{ V}$, $V_{DD3} = 4.5\text{ V}$,
 $T_a = 0\text{ to }+65^\circ\text{C}$ unless otherwise specified)

Parameter (Pin Name)	Symbol	Condition	Min.	Typ.	Max.	Unit	Measuring Circuit
Input Current 1 (P0.0 to P0.3) (P2.0 to P2.3) (P3.0 to P3.3) (P4.0 to P4.3)	I_{IH1}	$V_{IH1} = V_{DD}$ (when pulled down)	5.0	18	60	μA	3
	I_{IL1}	$V_{IL1} = V_{SS}$ (when pulled up)	-60	-18	-5.0	μA	
	I_{IH1S}	$V_{IH1} = V_{DD} = 5\text{ V}$ (when pulled down)	70	250	660	μA	
	I_{IL1S}	$V_{IL1} = V_{SS}$, $V_{DD} = 5\text{ V}$ (when pulled up)	-660	-250	-70	μA	
	I_{IH1Z}	$V_{IH1} = V_{DD}$ (in a high impedance state)	0	—	1.0	μA	
	I_{IL1Z}	$V_{IL1} = V_{SS}$ (in a high impedance state)	-1.0	—	0	μA	
Input Current 2 (IN0, IN1)	I_{IH2}	$V_{IH2} = V_{DD1}$ (when pulled down)	5.0	18	60	μA	3
	I_{IH2Z}	$V_{IH2} = V_{DD1}$ (in a high impedance state)	0	—	1.0	μA	
	I_{IL2Z}	$V_{IL2} = V_{SS}$ (in a high impedance state)	-1.0	—	0	μA	
Input Current 3 (OSC1)	I_{IL3}	$V_{IL3} = V_{SS}$ (when pulled up)	-60	-22	-6.0	μA	3
	I_{IH3Z}	$V_{IH3} = V_{DD1}$ (in a high impedance state)	0	—	1.0	μA	
	I_{IL3Z}	$V_{IL3} = V_{SS}$ (in a high impedance state)	-1.0	—	0	μA	
Input Current 4 (RESET, TST1, TST2)	I_{IH4}	$V_{IH4} = V_{DD1}$	0	—	1.0	μA	3
	I_{IL4}	$V_{IL4} = V_{SS}$	-1.0	-0.3	-0.1	mA	
Input Voltage 1 (P0.0 to P0.3) (P2.0 to P2.3) (P3.0 to P3.3) (P4.0 to P4.3)	V_{IH1}	—	1.2	—	1.5	V	4
	V_{IL1}	—	0	—	0.3	V	
	V_{IH1S}	$V_{DD} = 5\text{ V}$	4.0	—	5.0	V	
	V_{IL1S}	$V_{DD} = 5\text{ V}$	0	—	1.0	V	
Input Voltage 2 (IN0, IN1, OSC1)	V_{IH2}	—	1.2	—	1.5	V	4
	V_{IL2}	—	0	—	0.3	V	
Input Voltage 3 (RESET, TST1, TST2)	V_{IH3}	—	1.2	—	1.5	V	4
	V_{IL3}	—	0	—	0.3	V	

DC Characteristics (continued)

($V_{SS} = 0\text{ V}$, $V_{DD1} = V_{DD} = 1.5\text{ V}$, $V_{DD2} = 3.0\text{ V}$, $V_{DD3} = 4.5\text{ V}$,
 $T_a = 0\text{ to }+65^\circ\text{C}$ unless otherwise specified)

Parameter (Pin Name)	Symbol	Condition	Min.	Typ.	Max.	Unit	Measuring Circuit
Hysteresis Width (P0.0 to P0.3) (P2.0 to P2.3) (P3.0 to P3.3) (P4.0 to P4.3)	ΔV_{T1}	—	0.05	0.1	0.3	V	4
	ΔV_{T1S}	$V_{DD} = 5\text{ V}$	0.25	1.0	1.5	V	
Hysteresis Width (RESET, TST1, TST2)	ΔV_{T2}	—	0.05	0.1	0.3	V	
Input Pin Capacitance (P0.0 to P0.3) (P2.0 to P2.3) (P3.0 to P3.3) (P4.0 to P4.3)	C_{IN}	—	—	—	5.0	pF	1

Measuring circuit 1

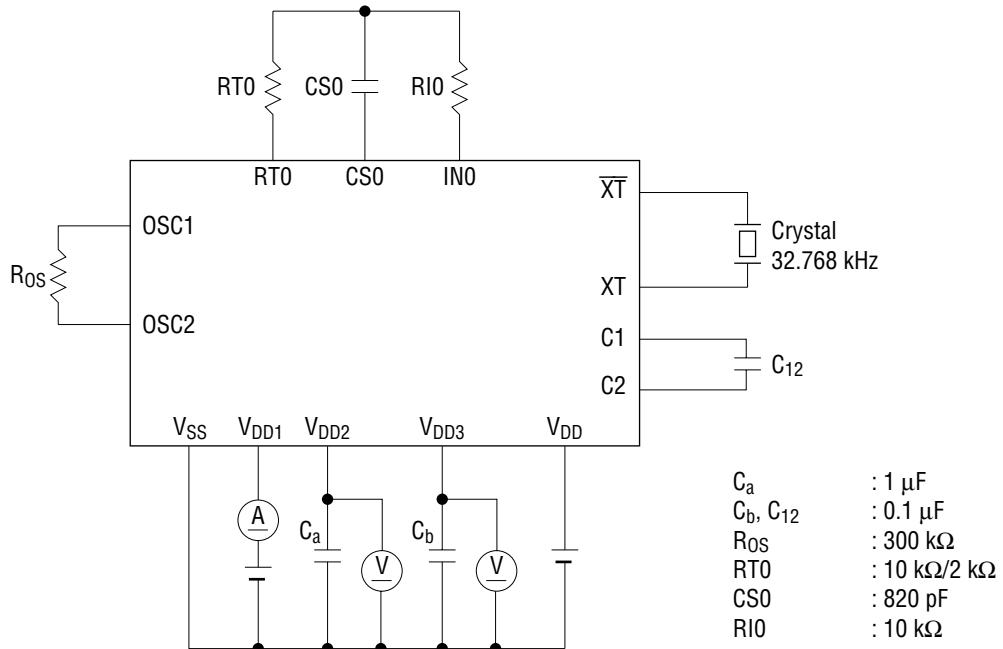

Measuring circuit 2

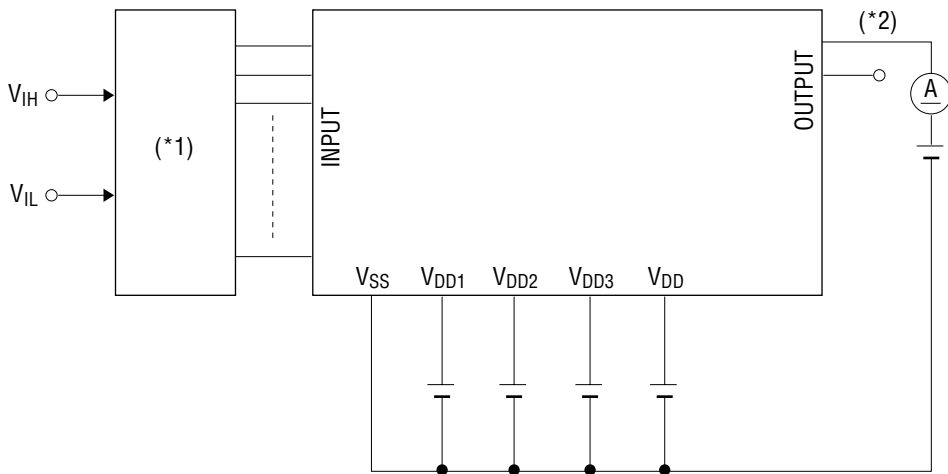

Measuring circuit 3

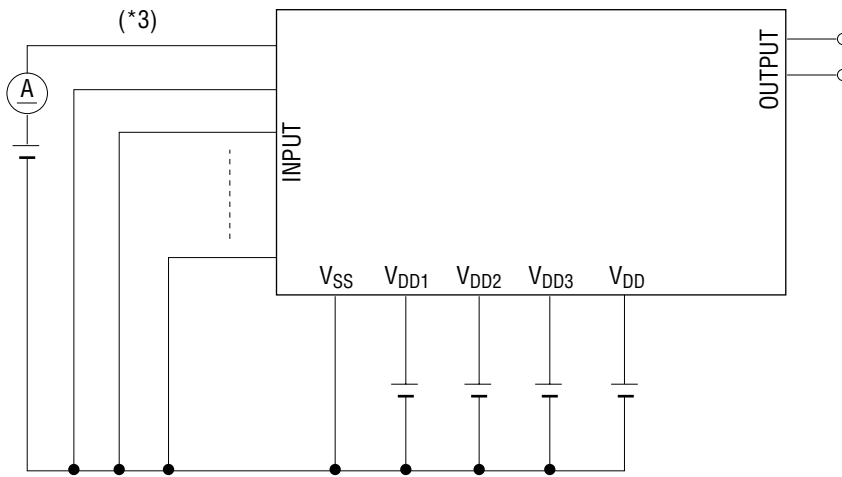

Measuring circuit 4

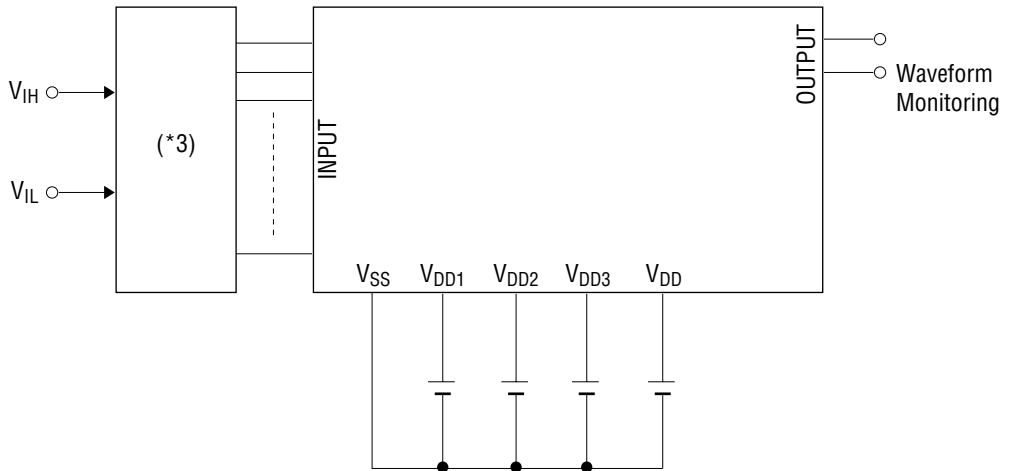

*1 Input logic circuit to determine the specified measuring conditions.

*2 Measured at the specified output pins.

*3 Measured at the specified input pins.

A/D Converter Characteristics

(V_{SS} = 0 V, V_{DD} = 1.5 V, Ta = 0 to +65°C unless otherwise specified)

Parameter	Symbol	Condition	Min.	Typ.	Max.	Unit	Measuring Circuit
Resistor for Oscillation	RS0, RS1, RT0, RT0-1, RT1	CS0, CT0, CS1 ≥ 740 pF	2.0	—	—	kΩ	5
Input Current Limiting Resistor	RI0, RI1	—	1.0	10	—	kΩ	
Oscillation Frequency	f _{OSC1}	Resistor for oscillation = 2 kΩ	165	221	256	kHz	
	f _{OSC2}	Resistor for oscillation = 10 kΩ	41.8	52.2	60.6	kHz	
	f _{OSC3}	Resistor for oscillation = 200 kΩ	2.55	3.04	3.53	kHz	
RS•RT Oscillation Frequency Ratio (*)	Kf1	RT0, RT0-1, RT1 = 2 kΩ	3.89	4.18	4.35	—	
	Kf2	RT0, RT0-1, RT1 = 10 kΩ	0.990	1.0	1.010	—	
	Kf3	RT0, RT0-1, RT1 = 200 kΩ	0.0561	0.0584	0.0637	—	

* Kfx is the ratio of the oscillation frequency by a sensor resistor to the oscillation frequency by a reference resistor in the same condition.

$$Kfx = \frac{f_{oscx} \text{ (RT0-CS0 Oscillation)}}{f_{oscx} \text{ (RS0-CS0 Oscillation)}} , \frac{f_{oscx} \text{ (RT0-1-CS0 Oscillation)}}{f_{oscx} \text{ (RS0-CS0 Oscillation)}} , \frac{f_{oscx} \text{ (RT1-CS1 Oscillation)}}{f_{oscx} \text{ (RS1-CS1 Oscillation)}} \\ (x = 1, 2, 3)$$

Measuring circuit 5

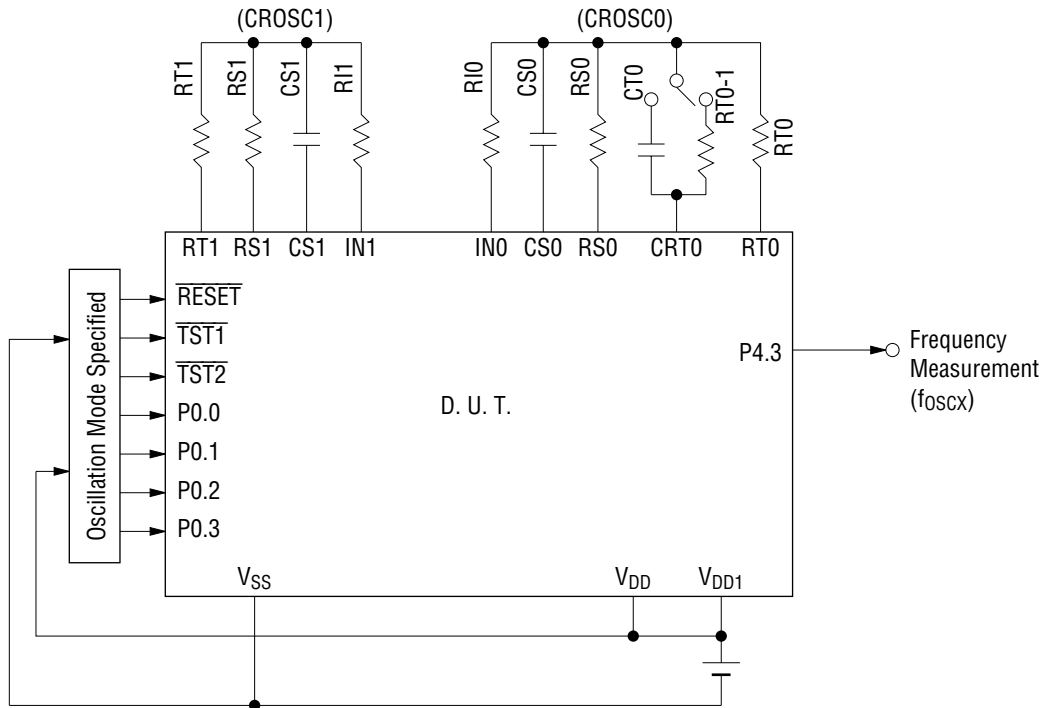

- RT0, RT0-1, RT1 = 2 kΩ/10 kΩ/200 kΩ
- RS0, RS1 = 10 kΩ
- RIO, RI1 = 10 kΩ
- CS0, CTO, CS1 = 820 pF

AC Characteristics (Serial Interface)

($V_{SS} = 0\text{ V}$, $V_{DD1} = 1.5\text{ V}$, $V_{DD} = 5\text{ V}$, $T_a = 0\text{ to }+65^\circ\text{C}$)

Parameter	Symbol	Condition	Min.	Typ.	Max.	Unit
SCLK Input Fall Time	t_f	—	—	15	50	ns
SCLK Input Rise Time	t_r	—	—	15	50	ns
SCLK Input "L" Level Pulse Width	t_{CWL}	—	0.8	—	—	μs
SCLK Input "H" Level Pulse Width	t_{CWH}	—	0.8	—	—	μs
SCLK Input Cycle Time	t_{CYC}	—	2.0	—	—	μs
SCLK Output Cycle Time	$t_{CYC1(0)}$	CPU is operating at 32.768 kHz.	—	30.5	—	μs
SCLK Output Cycle Time	$t_{CYC2(0)}$	CPU is operating at 400 kHz.	—	2.5	—	μs
SOUT Output Delay Time	t_{DDR}	$C_1 = 10\text{ pF}$	—	—	0.4	μs
SIN Input Setup Time	t_{DS}	—	0.5	—	—	μs
SIN Input Hold Time	t_{DH}	—	0.8	—	—	μs

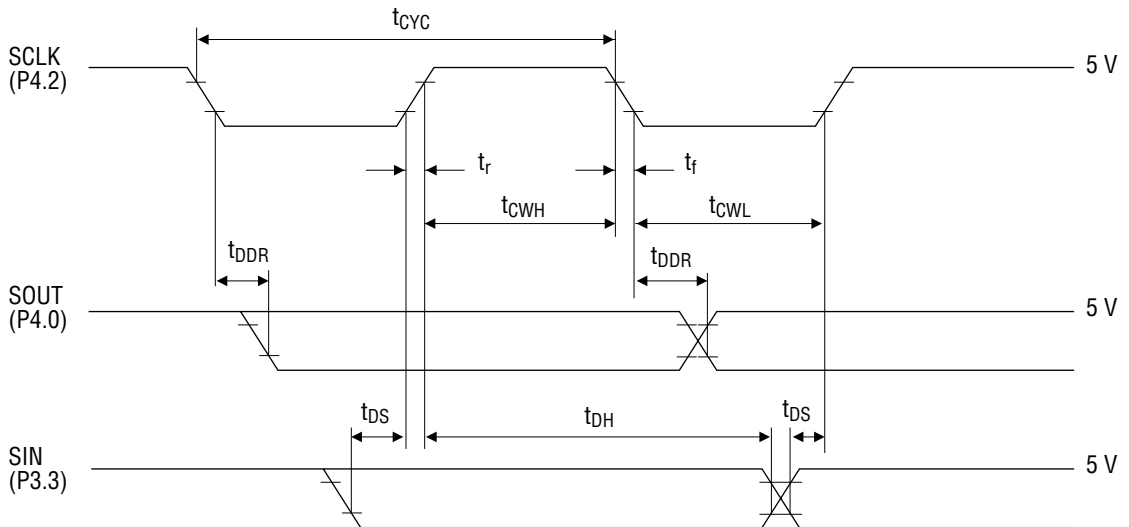

("H" level = 4 V, "L" level = 1 V)

ABSOLUTE MAXIMUM RATINGS (3.0 V Spec.)(V_{SS} = 0 V)

Parameter	Symbol	Condition	Rating	Unit
Power Supply Voltage 1	V _{DD1}	T _a = 25°C	-0.3 to +2.0	V
Power Supply Voltage 2	V _{DD2}	T _a = 25°C	-0.3 to +4.0	V
Power Supply Voltage 3	V _{DD3}	T _a = 25°C	-0.3 to +5.5	V
Power Supply Voltage 4	V _{DD}	T _a = 25°C	-0.3 to +5.5	V
Input Voltage 1	V _{IN1}	V _{DD2} input, T _a = 25°C	-0.3 to V _{DD2} + 0.3	V
Input Voltage 2	V _{IN2}	V _{DD} input, T _a = 25°C	-0.3 to V _{DD} + 0.3	V
Output Voltage 1	V _{OUT1}	V _{DD2} output, T _a = 25°C	-0.3 to V _{DD2} + 0.3	V
Output Voltage 2	V _{OUT2}	V _{DD3} output T _a = 25°C	-0.3 to V _{DD3} + 0.3	V
Output Voltage 3	V _{OUT3}	V _{DD} output, T _a = 25°C	-0.3 to V _{DD} + 0.3	V
Storage Temperature	T _{STG}	—	-55 to +150	°C

RECOMMENDED OPERATING CONDITIONS (3.0 V Spec.)(V_{SS} = 0 V)

Parameter	Symbol	Condition	Range	Unit
Operating Temperature	T _{OP}	—	0 to +65	°C
Operating Voltage	V _{DD2}	—	2.7 to 3.5	V
	V _{DD}	—	V _{DD2} to 5.25	V
External 400kHz RC Oscillator Resistance	R _{OS}	—	90 to 500	kΩ
Crystal Oscillation Frequency	f _{XT}	—	30 to 66	kHz

ELECTRICAL CHARACTERISTICS (3.0 V Spec.)

DC Characteristics

($V_{SS} = 0\text{ V}$, $V_{DD2} = V_{DD} = 3.0\text{ V}$, $T_a = 0\text{ to }+65^\circ\text{C}$ unless otherwise specified)

Parameter	Symbol	Condition	Min.	Typ.	Max.	Unit	Measuring Circuit
V_{DD1} Voltage	V_{DD1}	$C_a, C_b, C_{12} = 0.1\ \mu\text{F}$ +100% -20%	1.3	1.5	1.7	V	1
V_{DD3} Voltage	V_{DD3}	$C_a, C_b, C_{12} = 0.1\ \mu\text{F}$ +100% -20%	4.3	4.5	4.7	V	
Crystal Oscillation Start Voltage	V_{STA}	Oscillation start time: within 5 seconds	2.7	—	—	V	
Crystal Oscillation Hold Voltage	V_{HOLD}	—	2.7	—	—	V	
Crystal Oscillation Stop Detection Time	T_{STOP}	—	0.1	—	1000	ms	
Internal Crystal Oscillator Capacitance	C_G	—	10	15	20	pF	
External Crystal Oscillator Capacitance	C_{GEX}	When external C_G used	10	—	30	pF	
Internal Crystal Oscillator Capacitance	C_D	—	10	15	20	pF	
Internal 400k RC Oscillator Capacitance	C_{OS}	—	8	12	16	pF	
400k RC Oscillation Frequency	f_{OSC}	External resistor $R_{OS} = 100\ \text{k}\Omega$ $V_{DD2} = 2.7\text{ to }3.5\ \text{V}$	300	400	620	kHz	
POR Generation Voltage	V_{POR1}	When V_{DD2} is between V_{POR1} and 3.0 V	0	—	0.7	V	
POR Non-generation Voltage	V_{POR2}	No POR when V_{DD2} is between V_{POR2} and 3.0 V	2.7	—	3	V	

Notes: 1. "POR" denotes Power On Reset.

- " T_{STOP} " indicates that if the crystal oscillator stops over the value of T_{STOP} , the system reset occurs.

DC Characteristics (continued)

($V_{SS} = 0\text{ V}$, $V_{DD2} = V_{DD} = 3.0\text{ V}$, $T_a = 0\text{ to }+65^\circ\text{C}$ unless otherwise specified)

Parameter	Symbol	Condition	Min.	Typ.	Max.	Unit	Measuring Circuit
Supply Current 1	I_{DD1}	CPU in halt state (400k RC oscillation halt)	—	1.0	4.0	μA	1
Supply Current 2	I_{DD2}	CPU in operating state (400k RC oscillation halt)	—	25	50	μA	
Supply Current 3	I_{DD3}	CPU in operating state (400k RC oscillation in operation)	—	220	450	μA	
Supply Current 4	I_{DD4}	Serial transfer, $f_{SCK} = 300\text{ kHz}$, CPU in operating state (400k RC oscillation halt)	—	30	60	μA	
Supply Current 5	I_{DD5}	CPU in halt state (400k RC oscillation halt), RC oscillator for	$R_{T0} = 10\text{ k}\Omega$	—	300	450	
		A/D converter is in operating state	$R_{T0} = 2\text{ k}\Omega$	—	1300	2000	μA

DC Characteristics (continued)

($V_{SS} = 0\text{ V}$, $V_{DD1} = 1.5\text{ V}$, $V_{DD2} = V_{DD} = 3.0\text{ V}$, $V_{DD3} = 4.5\text{ V}$,
 $T_a = 0\text{ to }+65^\circ\text{C}$ unless otherwise specified)

Parameter (Pin Name)	Symbol	Condition	Min.	Typ.	Max.	Unit	Measuring Circuit
Output Current 1 (P1.0)	I_{OH1}	$V_{OH1} = V_{DD} - 0.5\text{ V}$	-6.0	-2.0	-0.7	mA	2
	I_{OL1}	$V_{OL1} = 0.5\text{ V}$	3.0	8.0	25	mA	
	I_{OL1S}	$V_{DD} = 5\text{ V}$, $V_{OL1} = 0.5\text{ V}$	4.0	12	36	mA	
Output Current 2 (P1.1 to P1.3) (P2.0 to P2.3) (P3.0 to P3.3) (P4.0 to P4.3)	I_{OH2}	$V_{OH2} = V_{DD} - 0.5\text{ V}$	-6.0	-2.0	-0.7	mA	
	I_{OL2}	$V_{OL2} = 0.5\text{ V}$	0.7	2.0	6.0	mA	
	I_{OL2S}	$V_{DD} = 5\text{ V}$, $V_{OL2} = 0.5\text{ V}$	1.0	3.0	9.0	mA	
Output Current 3 (BD)	I_{OH3}	$V_{OH3} = V_{DD2} - 0.7\text{ V}$	-6.0	-2.0	-0.7	mA	
	I_{OL3}	$V_{OL3} = 0.7\text{ V}$	0.7	2.0	6.0	mA	
Output Current 4 (RT0, RT1, RS0, RS1, CRT0, CS0, CS1)	I_{OH4}	$V_{OH4} = V_{DD2} - 0.1\text{ V}$	-2.5	-1.3	-0.7	mA	
	I_{OL4}	$V_{OL4} = 0.1\text{ V}$	0.7	1.3	2.5	mA	
Output Current 5 (When L26 to L33 are configured as output ports)	I_{OH5}	$V_{OH5} = V_{DD} - 0.5\text{ V}$	-1.5	-0.6	-0.15	mA	
	I_{OL5}	$V_{OL5} = 0.5\text{ V}$	0.15	0.6	1.5	mA	
	I_{OL5S}	$V_{DD} = 5\text{ V}$, $V_{OL5S} = 0.5\text{ V}$	0.2	0.7	2.0	mA	
Output Current 6 (OSC2)	I_{OH6}	$V_{OH6} = V_{DD2} - 0.5\text{ V}$	-6.0	-2.0	-0.7	mA	
	I_{OL6}	$V_{OL6} = 0.5\text{ V}$	0.7	2.0	6.0	mA	
Output Current 7 (L0 to L33)	I_{OH7}	$V_{OH7} = V_{DD3} - 0.2\text{ V}$ (V_{DD3} level)	—	—	-4.0	μA	
	I_{OMH7}	$V_{OMH7} = V_{DD2} + 0.2\text{ V}$ (V_{DD2} level)	4.0	—	—	μA	
	I_{OMH7S}	$V_{OMH7S} = V_{DD2} - 0.2\text{ V}$ (V_{DD2} level)	—	—	-4.0	μA	
	I_{OML7}	$V_{OML7} = V_{DD1} + 0.2\text{ V}$ (V_{DD1} level)	4.0	—	—	μA	
	I_{OML7S}	$V_{OML7S} = V_{DD1} - 0.2\text{ V}$ (V_{DD1} level)	—	—	-4.0	μA	
	I_{OL7}	$V_{OL7} = 0.2\text{ V}$ (V_{SS} level)	4.0	—	—	μA	
Output Leakage Current (P1.0 to P1.3) (P2.0 to P2.3) (P3.0 to P3.3) (P4.0 to P4.3) (RT0, RT1, RS0, RS1, CRT0, CS0, CS1)	I_{OOH}	$V_{OH} = V_{DD2}$	—	—	0.3	μA	
	I_{OOL}	$V_{OL} = V_{SS}$	-0.3	—	—	μA	

DC Characteristics (continued)

($V_{SS} = 0\text{ V}$, $V_{DD1} = 1.5\text{ V}$, $V_{DD2} = V_{DD} = 3.0\text{ V}$, $V_{DD3} = 4.5\text{ V}$,
 $T_a = 0\text{ to }+65^\circ\text{C}$ unless otherwise specified)

Parameter (Pin Name)	Symbol	Condition	Min.	Typ.	Max.	Unit	Measuring Circuit
Input Current 1 (P0.0 to P0.3) (P2.0 to P2.3) (P3.0 to P3.3) (P4.0 to P4.3)	I_{IH1}	$V_{IH1} = V_{DD}$ (when pulled down)	30	90	300	μA	3
	I_{IL1}	$V_{IL1} = V_{SS}$ (when pulled up)	-300	-90	-30	μA	
	I_{IH1S}	$V_{IH1} = V_{DD} = 5\text{ V}$ (when pulled down)	80	250	800	μA	
	I_{IL1S}	$V_{IL1} = V_{SS}$, $V_{DD} = 5\text{ V}$ (when pulled up)	-800	-250	-80	μA	
	I_{IH1Z}	$V_{IH1} = V_{DD}$ (in a high impedance state)	0	—	1.0	μA	
	I_{IL1Z}	$V_{IL1} = V_{SS}$ (in a high impedance state)	-1.0	—	0	μA	
Input Current 2 (IN0, IN1)	I_{IH2}	$V_{IH2} = V_{DD2}$ (when pulled down)	30	90	300	μA	3
	I_{IH2Z}	$V_{IH2} = V_{DD2}$ (in a high impedance state)	0	—	1.0	μA	
	I_{IL2Z}	$V_{IL2} = V_{SS2}$ (in a high impedance state)	-1.0	—	0	μA	
Input Current 3 (OSC1)	I_{IL3}	$V_{IL3} = V_{SS}$ (when pulled up)	-300	-110	-10	μA	3
	I_{IH3Z}	$V_{IH3} = V_{DD2}$ (in a high impedance state)	0	—	1.0	μA	
	I_{IL3Z}	$V_{IL3} = V_{SS}$ (in a high impedance state)	-1.0	—	0	μA	
Input Current 4 (RESET, TST1, TST2)	I_{IH4}	$V_{IH4} = V_{DD2}$	0	—	1.0	μA	3
	I_{IL4}	$V_{IL4} = V_{SS}$	-3.0	-1.5	-0.75	mA	
Input Voltage 1 (P0.0 to P0.3) (P2.0 to P2.3) (P3.0 to P3.3) (P4.0 to P4.3)	V_{IH1}	—	2.4	—	3.0	V	4
	V_{IL1}	—	0	—	0.6	V	
	V_{IH1S}	$V_{DD} = 5\text{ V}$	4.0	—	5.0	V	
	V_{IL1S}	$V_{DD} = 5\text{ V}$	0	—	1.0	V	
Input Voltage 2 (IN0, IN1, OSC1)	V_{IH2}	—	2.4	—	3.0	V	4
	V_{IL2}	—	0	—	0.6	V	
Input Voltage 3 (RESET, TST1, TST2)	V_{IH3}	—	2.4	—	3.0	V	4
	V_{IL3}	—	0	—	0.6	V	

DC Characteristics (continued)

($V_{SS} = 0\text{ V}$, $V_{DD1} = 1.5\text{ V}$, $V_{DD2} = V_{DD} = 3.0\text{ V}$, $V_{DD3} = 4.5\text{ V}$,
 $T_a = 0\text{ to }+65^\circ\text{C}$ unless otherwise specified)

Parameter (Pin Name)	Symbol	Condition	Min.	Typ.	Max.	Unit	Measuring Circuit
Hysteresis Width (P0.0 to P0.3) (P2.0 to P2.3) (P3.0 to P3.3) (P4.0 to P4.3)	ΔV_{T1}	—	0.2	0.5	1.0	V	4
	ΔV_{T1S}	$V_{DD} = 5\text{ V}$	0.25	1.0	1.5	V	
Hysteresis Width ($\overline{\text{RESET}}$, $\overline{\text{TST1}}$, $\overline{\text{TST2}}$)	ΔV_{T2}	—	0.2	0.5	1.0	V	
Input Pin Capacitance (P0.0 to P0.3) (P2.0 to P2.3) (P3.0 to P3.3) (P4.0 to P4.3)	C_{IN}	—	—	—	5.0	pF	1

Measuring circuit 1

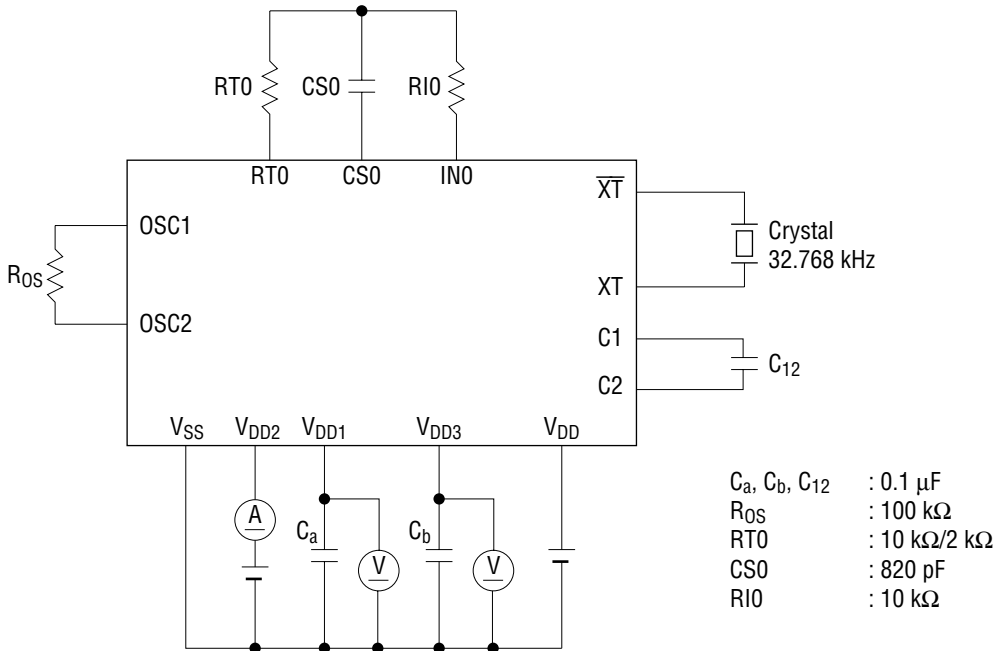

Measuring circuit 2

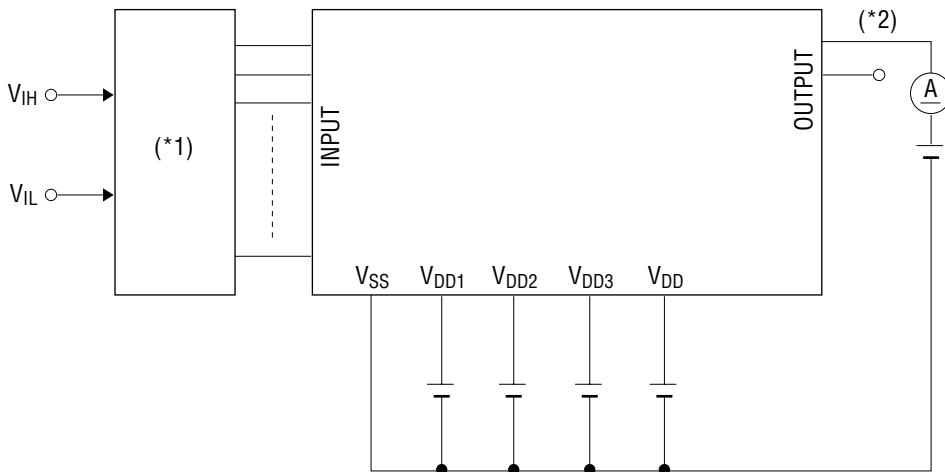

Measuring circuit 3

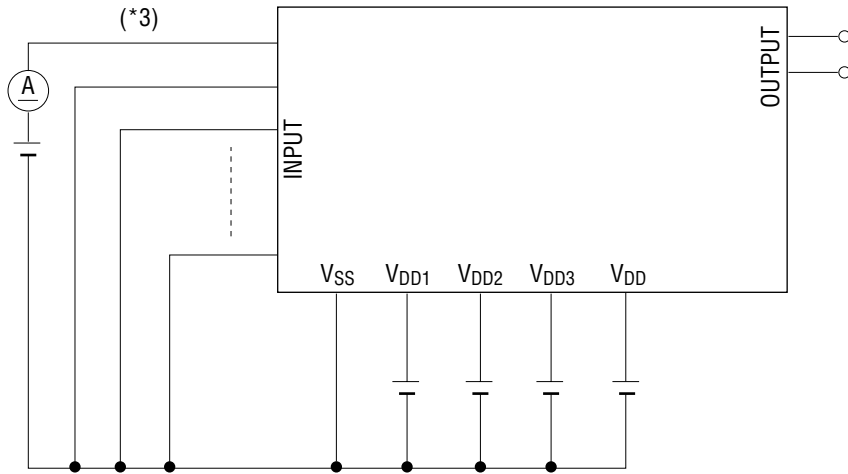

Measuring circuit 4

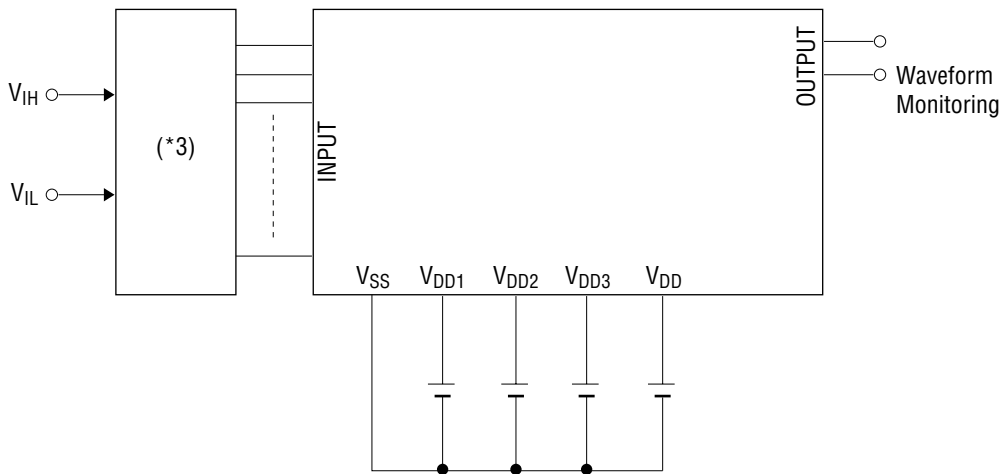

- *1 Input logic circuit to determine the specified measuring conditions.
- *2 Measured at the specified output pins.
- *3 Measured at the specified input pins.

A/D Converter Characteristics

(V_{SS} = 0 V, V_{DD2} = V_{DD} = 3.0 V, Ta = 0 to +65°C unless otherwise specified)

Parameter	Symbol	Condition	Min.	Typ.	Max.	Unit	Measuring Circuit
Resistor for Oscillation	RS0, RS1, RT0, RT0-1, RT1	CS0, CT0, CS1 ≥ 740 pF	1.0	—	—	kΩ	5
Input Current Limiting Resistor	RI0, RI1	—	1.0	10	—	kΩ	
Oscillation Frequency	f _{OSC1}	Resistor for oscillation = 2 kΩ	200	239	277	kHz	
	f _{OSC2}	Resistor for oscillation = 10 kΩ	46.5	55.4	64.3	kHz	
	f _{OSC3}	Resistor for oscillation = 200 kΩ	2.79	3.32	3.85	kHz	
RS•RT Oscillation Frequency Ratio (*)	Kf1	RT0, RT0-1, RT1 = 2 kΩ	4.115	4.22	4.326	—	
	Kf2	RT0, RT0-1, RT1 = 10 kΩ	0.990	1.0	1.010	—	
	Kf3	RT0, RT0-1, RT1 = 200 kΩ	0.0573	0.0616	0.0659	—	

* K_{fx} is the ratio of the oscillation frequency by a sensor resistor to the oscillation frequency by a reference resistor in the same condition.

$$K_{fx} = \frac{f_{OSCx} \text{ (RT0-CS0 Oscillation)}}{f_{OSCx} \text{ (RS0-CS0 Oscillation)}}, \frac{f_{OSCx} \text{ (RT0-1-CS0 Oscillation)}}{f_{OSCx} \text{ (RS0-CS0 Oscillation)}}, \frac{f_{OSCx} \text{ (RT1-CS1 Oscillation)}}{f_{OSCx} \text{ (RS1-CS1 Oscillation)}} \quad (x = 1, 2, 3)$$

Measuring circuit 5

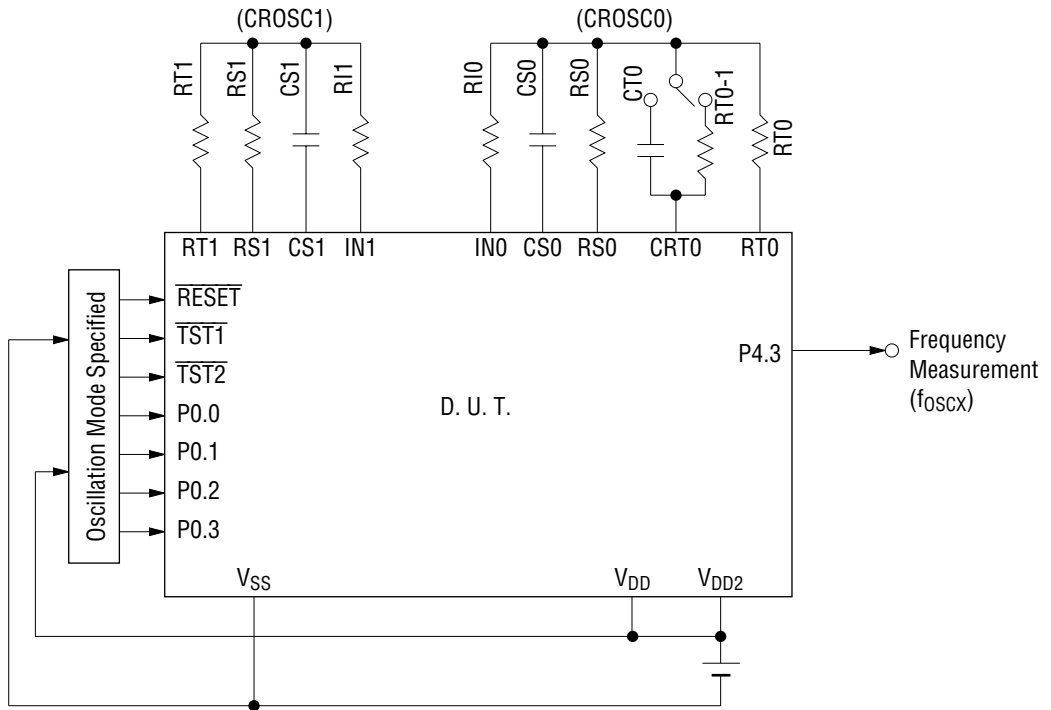

- RT0, RT0-1, RT1 = 2 kΩ/10 kΩ/200 kΩ
- RS0, RS1 = 10 kΩ
- R10, R11 = 10 kΩ
- CS0, CTO, CS1 = 820 pF

AC Characteristics (Serial Interface)

($V_{SS} = 0\text{ V}$, $V_{DD2} = 3\text{ V}$, $V_{DD} = 5\text{ V}$, $T_a = 0\text{ to }+65^\circ\text{C}$)

Parameter	Symbol	Condition	Min.	Typ.	Max.	Unit
SCLK Input Fall Time	t_f	—	—	15	50	ns
SCLK Input Rise Time	t_r	—	—	15	50	ns
SCLK Input "L" Level Pulse Width	t_{CWL}	—	0.8	—	—	μs
SCLK Input "H" Level Pulse Width	t_{CWH}	—	0.8	—	—	μs
SCLK Input Cycle Time	t_{CYC}	—	2.0	—	—	μs
SCLK Output Cycle Time	$t_{CYC1(0)}$	CPU is operating at 32.768 kHz.	—	30.5	—	μs
SCLK Output Cycle Time	$t_{CYC2(0)}$	CPU is operating at 400 kHz.	—	2.5	—	μs
SOUT Output Delay Time	t_{DDR}	$C_1 = 10\text{ pF}$	—	—	0.4	μs
SIN Input Setup Time	t_{DS}	—	0.5	—	—	μs
SIN Input Hold Time	t_{DH}	—	0.8	—	—	μs

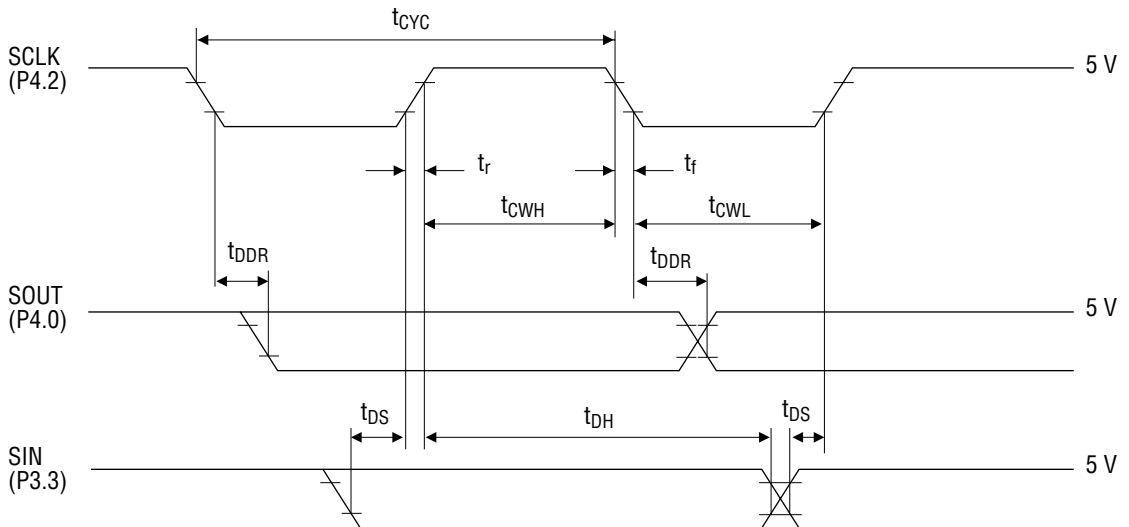

("H" level = 4 V, "L" level = 1 V)

ABSOLUTE MAXIMUM RATINGS (1.5 V/3.0 V Spec., PROM Mode)

(V_{SS} = 0 V)

Parameter	Symbol	Condition	Rating	Unit
PROM Power Supply Voltage	V _{CC}	V _{CC} = V _{DD1} = V _{DD2} , Ta = 25°C	-0.3 to +6.7	V
Program Voltage	V _{PP}	Ta = 25°C	-0.3 to +14.0	V
PROM Input Voltage	V _I	V _{CC} input, Ta = 25°C	-0.3 to V _{CC} + 0.3	V
PROM Output Voltage	V _O	V _{CC} output, Ta = 25°C	-0.3 to V _{CC} + 0.3	V
Storage Temperature	T _{STG}	—	-55 to +150	°C

RECOMMENDED OPERATING CONDITIONS (1.5 V/3.0 V Spec., PROM Mode)

(V_{SS} = 0 V)

Parameter	Symbol	Condition	Range	Unit
Operating Temperature	T _{op}	—	0 to 65	°C
V _{CC} Power Supply Voltage	V _{CC}	V _{CC} = V _{DD1} = V _{DD2}	4.75 to 5.25	V
V _{PP} Power Supply Voltage	V _{PP}	During read	4.75 to 5.25	V
		During write	12.0 to 13.0	V
Input Voltage	V _{IH}	V _{CC} = V _{DD1} = V _{DD2}	4 to V _{CC}	V
	V _{IL}	—	0 to 1	V

ELECTRICAL CHARACTERISTICS (1.5 V/3.0 V Spec., PROM Mode)

(1) Read Operation

DC Characteristics

($V_{DD1} = V_{DD2} = V_{PP} = 5\text{ V} \pm 5\%$, $T_a = 25^\circ\text{C} \pm 5^\circ\text{C}$, unless otherwise specified)

Parameter	Symbol	Condition	Min.	Typ.	Max.	Unit
V_{CC} Power Supply Current (Standby)	I_{CC1}	$V_{CC} = V_{DD1} = V_{DD2}$ $\overline{CE} = V_{IH}$	—	—	35	mA
V_{CC} Power Supply Current (Operating)	I_{CC2}	$V_{CC} = V_{DD1} = V_{DD2}$ $\overline{CE} = V_{IL}$	—	—	100	mA
Input Voltage	V_{IH}	$V_{CC} = V_{DD1} = V_{DD2}$	4.0	—	V_{CC}	V
	V_{IL}	—	0	—	1.0	V
Output Current	I_{OH}	$V_{CC} = V_{DD1} = V_{DD2}$ $V_{OH} = V_{CC} - 0.5\text{ V}$	-2.0	-0.7	-0.2	mA
	I_{OL}	$V_{OL} = 0.5\text{ V}$	0.2	0.7	2.0	mA

AC Characteristics

($V_{CC} = 5\text{ V} \pm 5\%$, $V_{PP} = V_{CC}$, $T_a = 25^\circ\text{C} \pm 5^\circ\text{C}$, unless otherwise specified)

Parameter	Symbol	Condition	Min.	Typ.	Max.	Unit
Address Access Time	t_{ACC}	$\overline{OE} = \overline{CE} = V_{IL}$	—	—	120	ns
\overline{CE} Access Time	t_{CE}	$\overline{OE} = V_{IL}$	—	—	120	ns
\overline{OE} Access Time	t_{OE}	$\overline{CE} = V_{IL}$	—	—	50	ns
Output Disable Time	t_{DF}	$\overline{CE} = V_{IL}$	0	—	40	ns

Measurement conditions:

Input pulse level 0.45 V to 4.55 V

Input rise/fall time 5 ns

Threshold level input 0.8 V, 2 V/output 0.8 V, 2 V

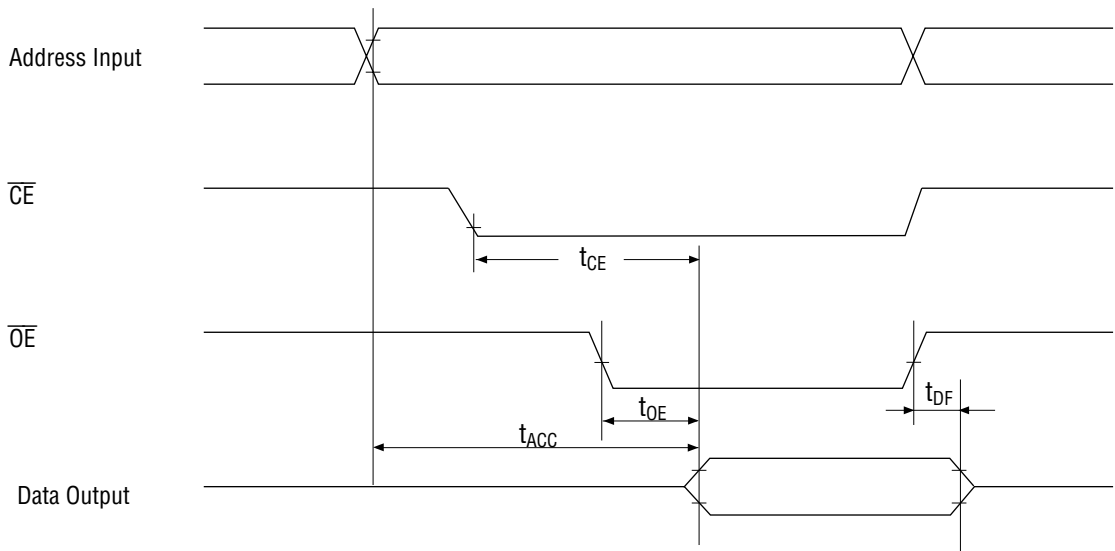

(2) Write Operation

DC Characteristics

($V_{SS} = 0\text{ V}$, $V_{DD1} = V_{DD2} = 5\text{ V} \pm 5\%$, $V_{PP} = 12.5\text{ V} \pm 0.5\text{ V}$, $T_a = 25^\circ\text{C} \pm 5^\circ\text{C}$, unless otherwise specified)

Parameter	Symbol	Condition	Min.	Typ.	Max.	Unit
V_{PP} Power Supply Current	I_{PP}	$\overline{CE} = V_{IL}$	—	—	50	mA
V_{CC} Power Supply Current	I_{CC}	$V_{CC} = V_{DD1} = V_{DD2}$	—	—	100	mA
Input Voltage	V_{IH}	$V_{CC} = V_{DD1} = V_{DD2}$	4.0	—	V_{CC}	V
	V_{IL}	—	0	—	1.0	V
Output Current	I_{OH}	$V_{CC} = V_{DD1} = V_{DD2}$ $V_{OH} = V_{CC} - 0.5\text{ V}$	-2.0	-0.7	-0.2	mA
	I_{OL}	$V_{OL} = 0.5\text{ V}$	0.2	0.7	2.0	mA

AC Characteristics

($V_{SS} = 0\text{ V}$, $V_{DD1} = V_{DD2} = 5\text{ V} \pm 5\%$, $V_{PP} = 12.5\text{ V} \pm 0.5\text{ V}$, $T_a = 25^\circ\text{C} \pm 5^\circ\text{C}$, unless otherwise specified)

Parameter	Symbol	Condition	Min.	Typ.	Max.	Unit
Address Setup Time	t_{AS}	—	2.0	—	—	μs
\overline{OE} Setup Time	t_{OES}	—	2.0	—	—	μs
Data Setup Time	t_{DS}	—	2.0	—	—	μs
Address Hold Time	t_{AH}	—	0	—	—	μs
Data Hold Time	t_{DH}	—	2.0	—	—	μs
\overline{OE} Output Floating Delay Time	t_{DFP}	—	0	—	130	ns
V_{PP} Power Source Setup Time	t_{VS}	—	2.0	—	—	μs
Initial Program Pulse Width	t_{PW}	$V_{DD1} = V_{DD2}$ $6\text{ V} \pm 0.25\text{ V}$	0.95	1.0	1.05	ms
Additional Program Pulse Width	t_{OPW}	$V_{DD1} = V_{DD2}$ $6\text{ V} \pm 0.25\text{ V}$	2.85	—	78.75	ms
\overline{OE} Output Effective Delay Time	t_{OE}	—	—	—	150	ns

Measurement conditions:

Input pulse level 0.45 V to 4.55 V

Input rise/fall time less than 20 ns

Threshold level input 0.8 V, 2 V/output 0.8 V, 2 V

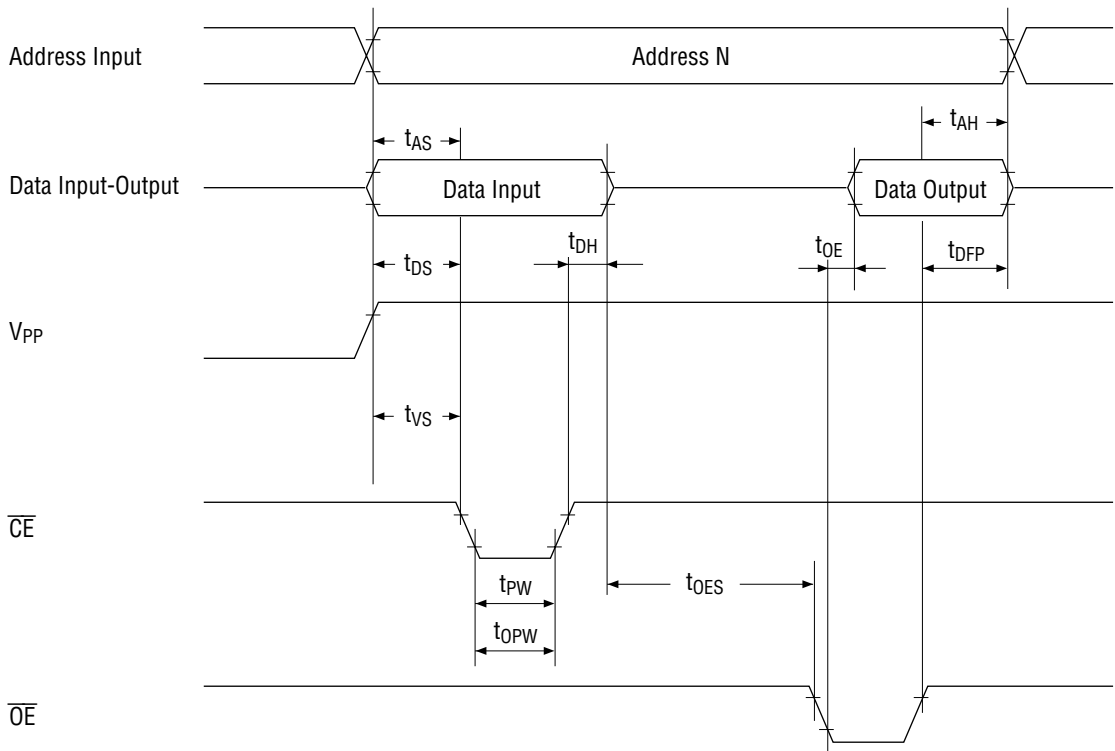

APPLICATION CIRCUITS

1.5 V Spec. Application Circuit

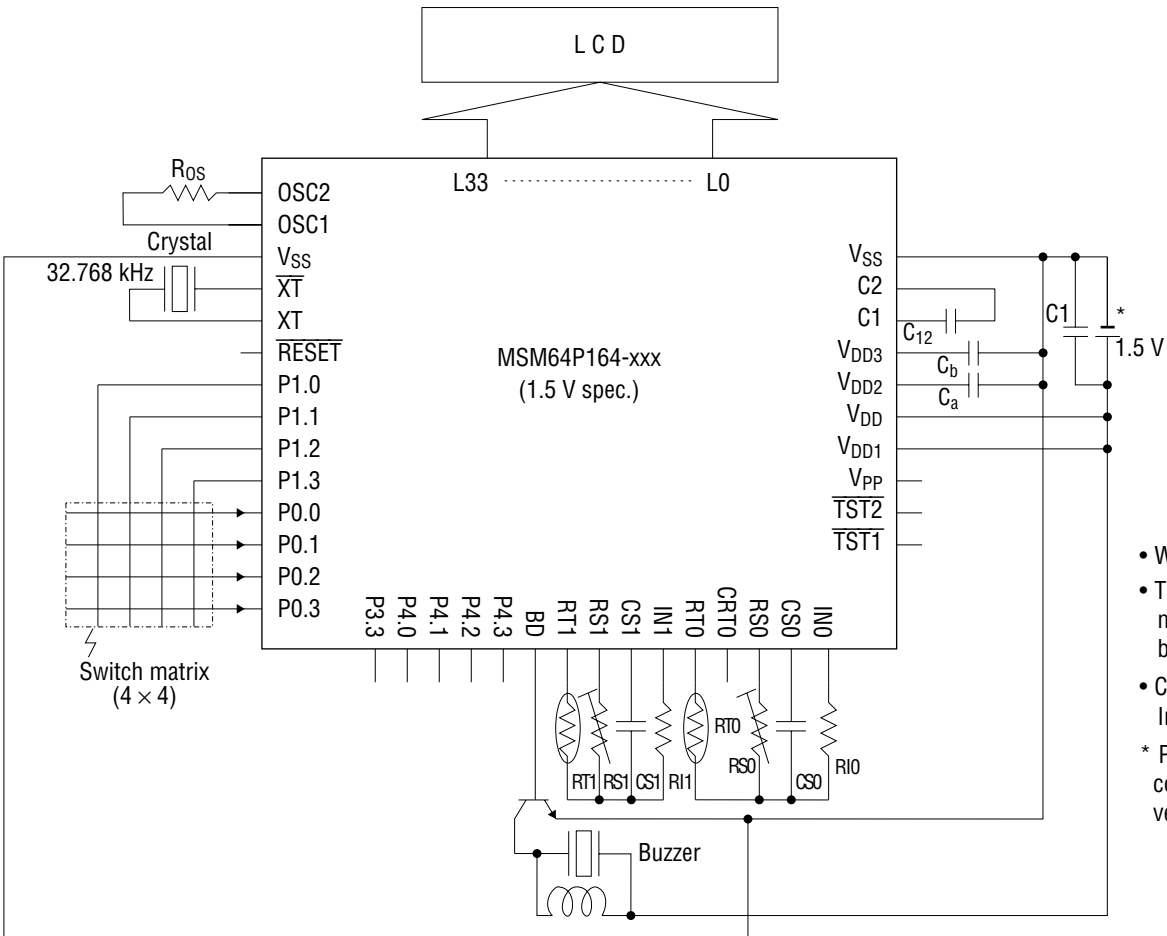

- Without 5 V interface
 - Temperature measurement by two thermistors
 - C_G of crystal oscillator : Internal
- * Polarity is reversed when compared to mask ROM version of this device.

APPLICATION CIRCUITS (continued)

3.0 V Spec. Application Circuit

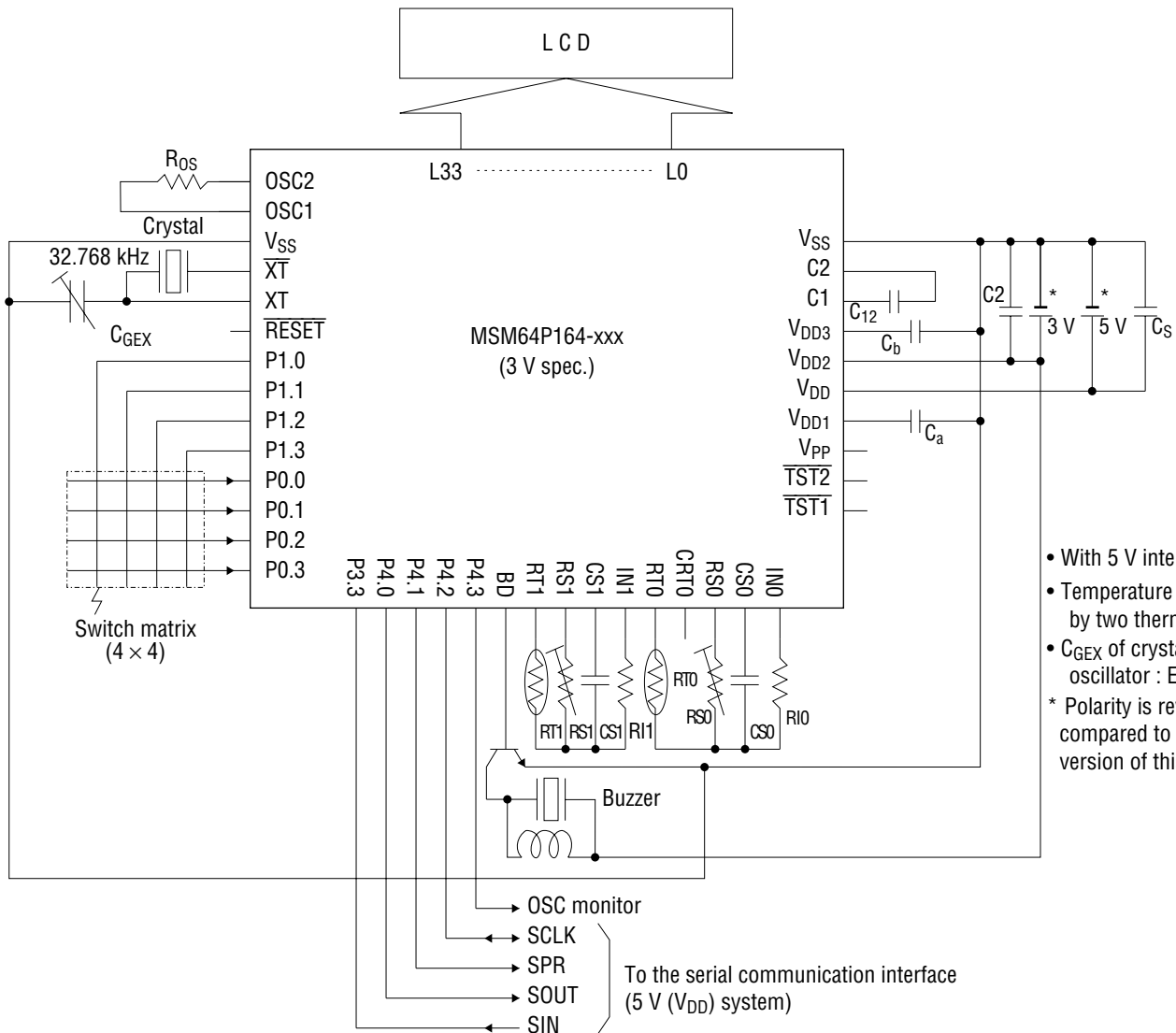

- With 5 V interface
- Temperature measurement by two thermistors
- C_{GEX} of crystal oscillator : External
- * Polarity is reversed when compared to mask ROM version of this device.

PACKAGE DIMENSIONS

(Unit : mm)

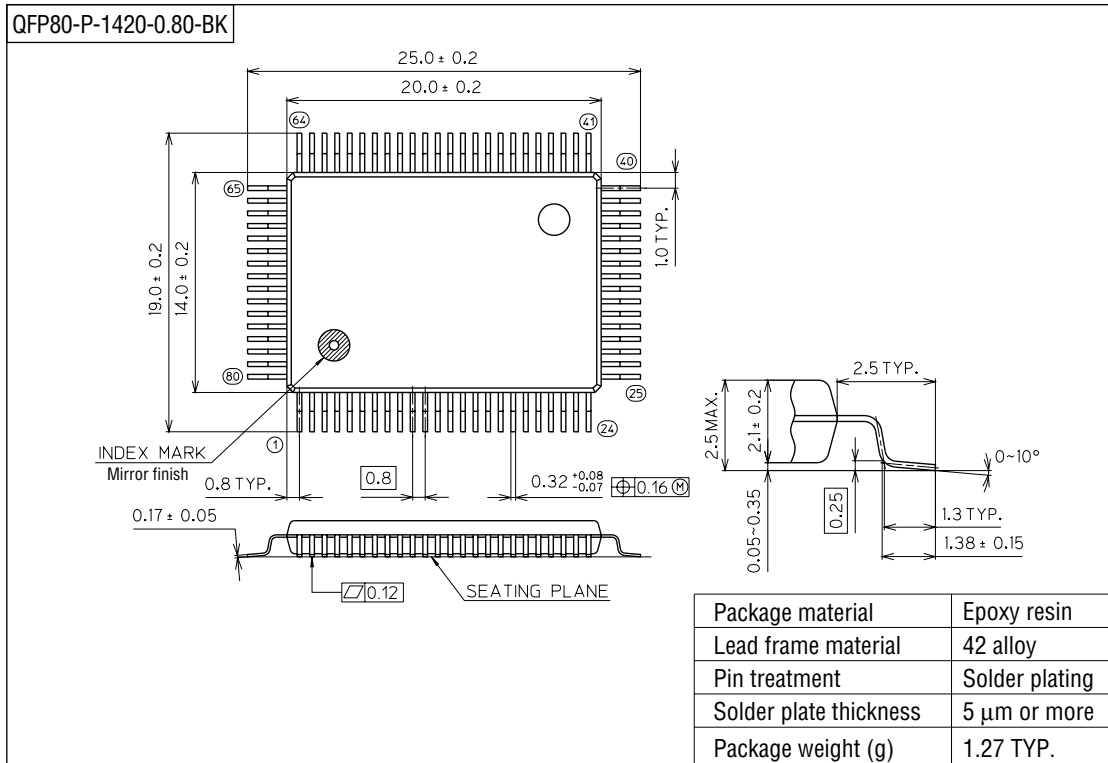

Notes for Mounting the Surface Mount Type Package

The SOP, QFP, TSOP, SOJ, QFJ (PLCC), SHP and BGA are surface mount type packages, which are very susceptible to heat in reflow mounting and humidity absorbed in storage. Therefore, before you perform reflow mounting, contact Oki's responsible sales person for the product name, package name, pin number, package code and desired mounting conditions (reflow method, temperature and times).