

OKI Semiconductor

MSM6685A

8,388,608-Word x 1-Bit Serial Register

GENERAL DESCRIPTION

The MSM6685A is a serial register composed of 8,388,608 words x one bit, characterized by medium-speed, low power consumption operation.

This device has a built-in internal address generation circuit allowing continuous serial read/write operation by external clock input. Read/write operation causes the internal address to be incremented automatically by +1.

External address input enables addressing in units of 1024 words. Furthermore, a refresh timer and a refresh address counter are installed, which makes an external refresh circuit unnecessary. In addition, this configuration allows lower power consumption.

The device is packaged in 26-pin SOJ having a width of 300 mil.

It is well adapted for storing much data by means of a battery backup. Its combination with OKI's recording and playback IC enables the easy implementation of a solid recording and playback system.

FEATURES

- Configuration : 8,388,608 × 1 bit
- Serial access operation
 - Serial access time : 1.5 μs
 - Serial read/write time : 2.5 μs
- Low current drain : 200 μA max. ($V_{CC} = 4V$, at refresh operation, with data stored and under standard conditions)
- Refresh operation
 - A self-refresh function is supported.
- Wide range of operating voltage : Single 3.5 to 5.5 V supply
- Addressing : In units of 1024 words
- Process : 0.45 μm double well CMOS process
- Package:
 - 26/20-pin plastic SOJ (SOJ26/20-P-300-1.27) (Product name : MSM6685AJS)

BLOCK DIAGRAM

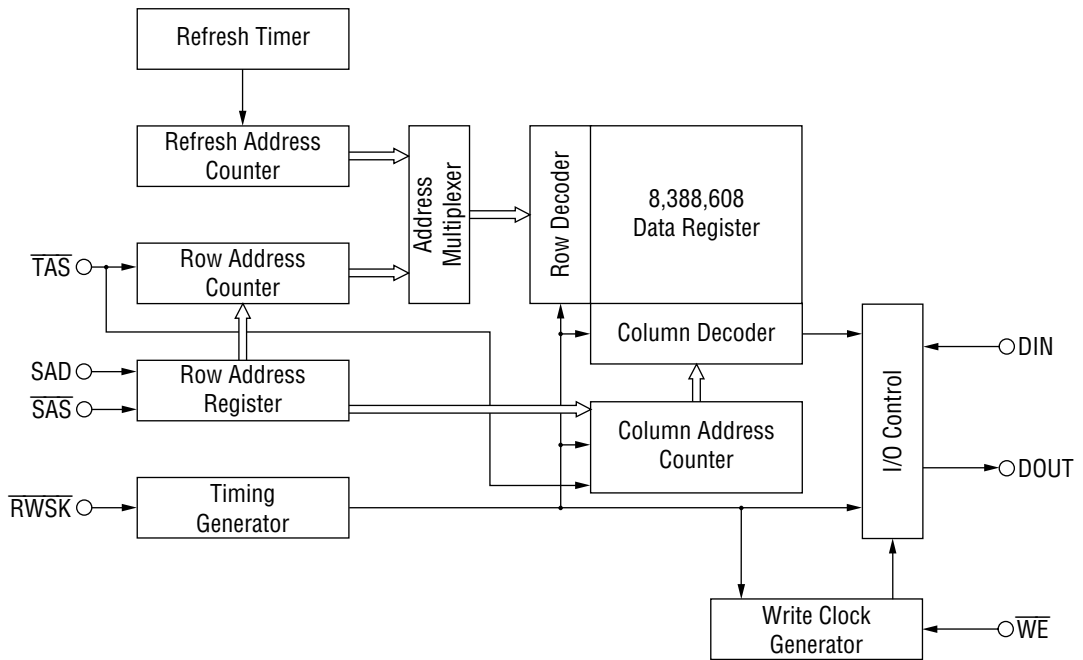

PIN CONFIGURATION (TOP VIEW)

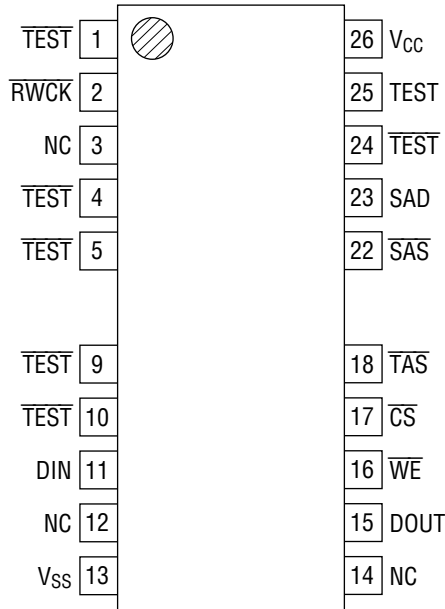

NC : No connection

26/20-Pin Plastic SOJ

PIN DESCRIPTION

Pin	Symbol	Description
25	TEST	Test input
1, 4, 5 9, 10, 24	$\overline{\text{TEST}}$	Test input
2	$\overline{\text{RWCK}}$	Read/write clock
11	DIN	Data input
13	V _{SS}	Ground (0 V)
15	DOUT	Data output
16	$\overline{\text{WE}}$	Write enable
17	$\overline{\text{CS}}$	Chip select
18	$\overline{\text{TAS}}$	Transfer address strobe
22	$\overline{\text{SAS}}$	Serial address strobe
23	SAD	Serial address data
26	V _{CC}	Power supply (5 V)

Note : All $\overline{\text{TEST}}$ pins are to be connected to the power supply.
The TEST pin is to be referenced to the ground level.

ABSOLUTE MAXIMUM RATINGS

Parameter	Symbol	Condition	Rating	Unit
Pin Voltage	V_T	Against V_{SS} at $T_a = 25\text{ }^\circ\text{C}$	-1.0 to +7.0	V
Short-circuit Output Current	I_{OS}	$T_a = 25\text{ }^\circ\text{C}$	50	mA
Power Dissipation	P_D	$T_a = 25\text{ }^\circ\text{C}$	1	W
Operating Temperature	T_{op}	—	0 to 70	$^\circ\text{C}$
Storage Temperature	T_{STG}	—	-55 to +150	$^\circ\text{C}$

RECOMMENDED OPERATING CONDITIONS

(Ta = 0 to 70°C)

Parameter	Symbol	Min	Typ	Max	Unit
Supply Voltage	V_{CC}	3.5	4.5	5.5	V
Supply Voltage	V_{SS}	0	0	0	V
"H" Input Voltage	V_{IH}	$V_{CC} - 0.5$	V_{CC}	$V_{CC} + 0.2$	V
"L" Input Voltage	V_{IL}	-0.2	0	+0.5	V

ELECTRICAL CHARACTERISTICS**DC Characteristics**(V_{CC} = 3.5V to 5.5V, Ta = 0 to 70°C)

Parameter	Symbol	Condition	Min	Max	Unit
"H" Output Voltage	V_{OH}	$I_{OH} = -0.5\text{ mA}$	$V_{CC} - 0.5$	—	V
"L" Output Voltage	V_{OL}	$I_{OL} = 0.5\text{ mA}$	—	0.4	V
Input Leakage Current	I_{IL}	$V_I = 0\text{ V to } V_{CC}$	-1	+1	μA
Output Leakage Current	I_{OL}	$V_O = 0\text{ V to } V_{CC}$	-1	+1	μA
Supply Current (Operation)	I_{CC1}	$V_{CC} = 4\text{ V, } t_{RWC} = 1\text{ }\mu\text{s}$	—	20	mA
Supply Current (Standby)	I_{CC2}	$V_{CC} = 4\text{ V}$	—	200	μA

AC Characteristics

(V_{CC} = 3.5 V to 5.5 V, T_a = 0 to 70°C)

Parameter	Symbol	Min	Max	Unit
Read/Write Cycle Time	t _{RWC}	2,500	—	ns
Access Time	t _{ACC}	—	1,500	ns
Output Turn-off Delay Time	t _{OFF}	0	50	ns
I/O Signal Rise Time	t _T	3	50	ns
RWCK Pre-charge Time	t _{RWP}	1,000	—	ns
RWCK Pulse Time	t _{RW}	1,500	10,000	ns
SAS Cycle Time	t _{SSC}	100	—	ns
SAS Pre-charge Time	t _{SAP}	50	—	ns
SAS Pulse Duration	t _{SAS}	50	—	ns
Address Setup Time	t _{AS}	0	—	ns
Address Hold Time	t _{AH}	50	—	ns
TAS Setup Time	t _{ATS}	50	—	ns
TAS . RWCK Setup Time	t _{TRS}	50	—	ns
TAS Pulse Duration	t _{TAS}	50	—	ns
Read Instruction Setup Time	t _{RRS}	0	—	ns
Read Instruction Hold Time	t _{RRH}	250	—	ns
Write Instruction Setup Time	t _{WRS}	0	—	ns
Write Instruction Hold Time	t _{WRH}	50	—	ns
Write Instruction Pulse Duration	t _{WP}	50	—	ns
WE. RWCK Read Time	t _{RWL}	50	—	ns
Data Setup Time	t _{DS}	0	—	ns
Data Hold Time	t _{DH}	50	—	ns
RWCK. WE Delay Time	t _{RWD}	50	—	ns

TIMING DIAGRAM
Read/Write and Read/Modify/Write Cycles

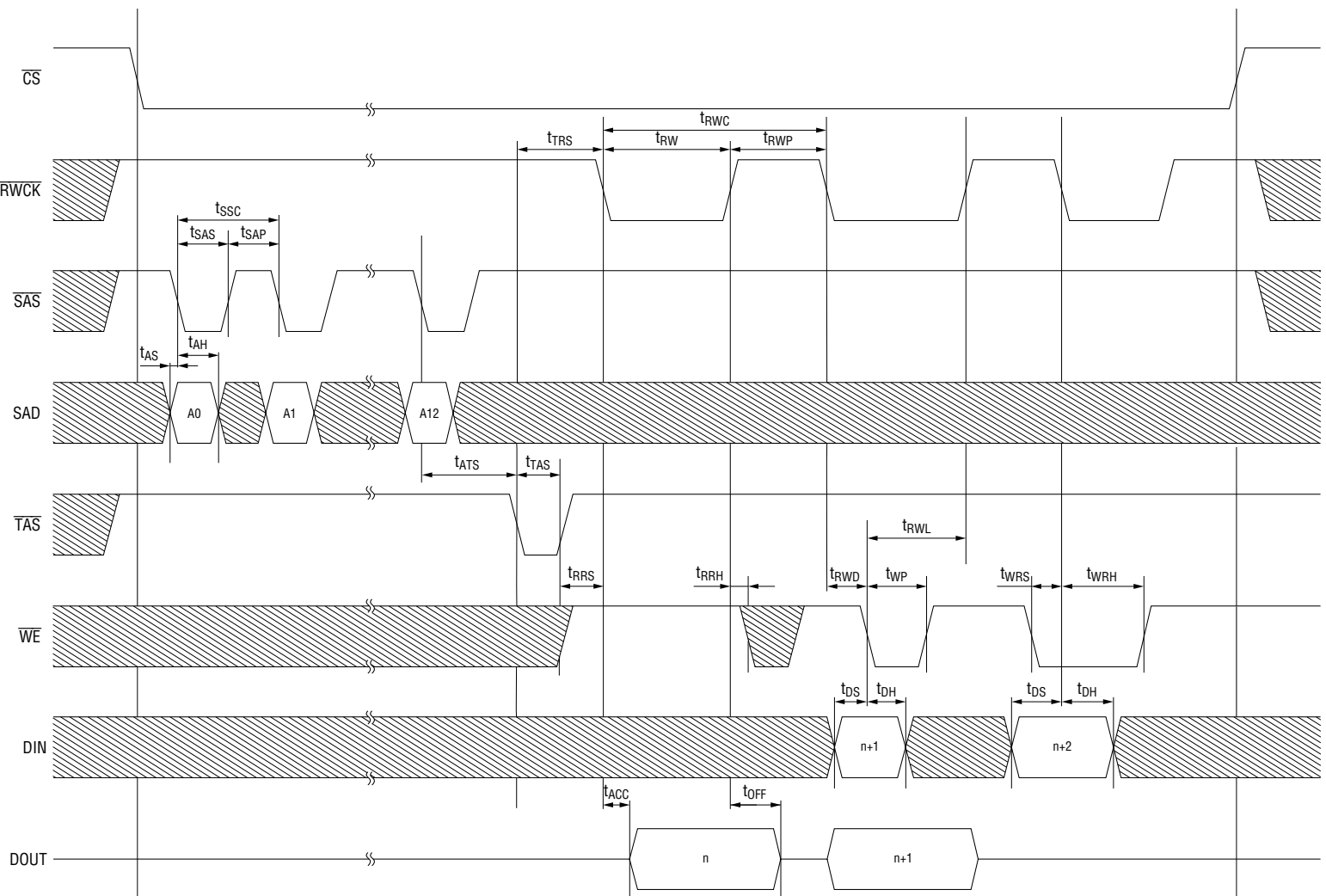

PIN FUNCTIONS AND OPERATING MODES

- Serial address input (SAD)

Pin used to enter start address for reading/writing. An address can be specified in units of 1024 words. 1024 words of address data can be entered through the pin as 13 bits (A0 to A12) of serial data.

- Serial address strobe (\overline{SAS})

This is a clock pin for latching serial address data into an internal register.

- Address transfer strobe (\overline{TAS})

This is an input pin for loading the internal address counter with serial address data latched in the address register.

- Read/write clock (\overline{RWCK})

This is a clock input pin for reading and writing information in the data register. The trailing edge of \overline{RWCK} triggers off internal operation. In the reading mode, information in the data register is output to the DOUT pin. In the writing mode, the data register is loaded with DIN information. At the leading edge of \overline{RWCK} , the internal address counter is incremented automatically by +1.

- Write enable (\overline{WE})

This is an input pin for selecting the read mode, the write mode, or the read-modify-write mode. When \overline{WE} is "H", the read mode is set up and, when \overline{WE} is "L", the write mode is set up. When the level is lowered from "H" to "L" with \overline{RWCK} active, the read-modify-write mode is set up.

- Data input (DIN)

This is a pin for entering write data. Information on the data input pin is latched when the trailing edge of \overline{RWCK} is encountered in the write mode and that of \overline{WE} is encountered in the read-modify mode.

- Data output (DOUT)

The data output pin always provides high impedance as long as \overline{RWCK} or \overline{CS} is kept at "H". When "H" or "L" information is read, the output pin set at "H" or "L", and information read is held until \overline{RWCK} returns to "H". In the early write mode, the output pin is maintained at high impedance, so that, connection of DIN and DOUT enables "I/O common operation".

- Chip select (\overline{CS})

This is an input pin for disabling all input pins. This pin allows the use of two or more MSM6684A devices with data input and output pins connected in parallel.

- Test (TEST, \overline{TEST})

The TEST pin must always be fixed at "L" and the \overline{TEST} pin at "H".

NOTES ON ENERGIZATION

MSM6685A has built-in bias generator and internal power supply circuits, thus, power up must be followed by a pause of 1 ms or more for internal circuit stabilization. Furthermore, the TEST pin must be brought "L" concurrently with or prior to V_{CC} , and all clock input pins and TEST pins must be brought "H" concurrently with or prior to V_{CC} .

To achieve proper operation of internal circuits, the initial pause above must be followed by a minimum ten dummy read cycles with \overline{RWCK} for internal circuit initialization.

NOTES ON SUPPLY VOLTAGE VARIATION

When using MSM6685A, take precautions so that the supply voltage does not vary over one volt within a period of 1,000 μ s or less in the active state.

PACKAGE DIMENSIONS

(Unit : mm)

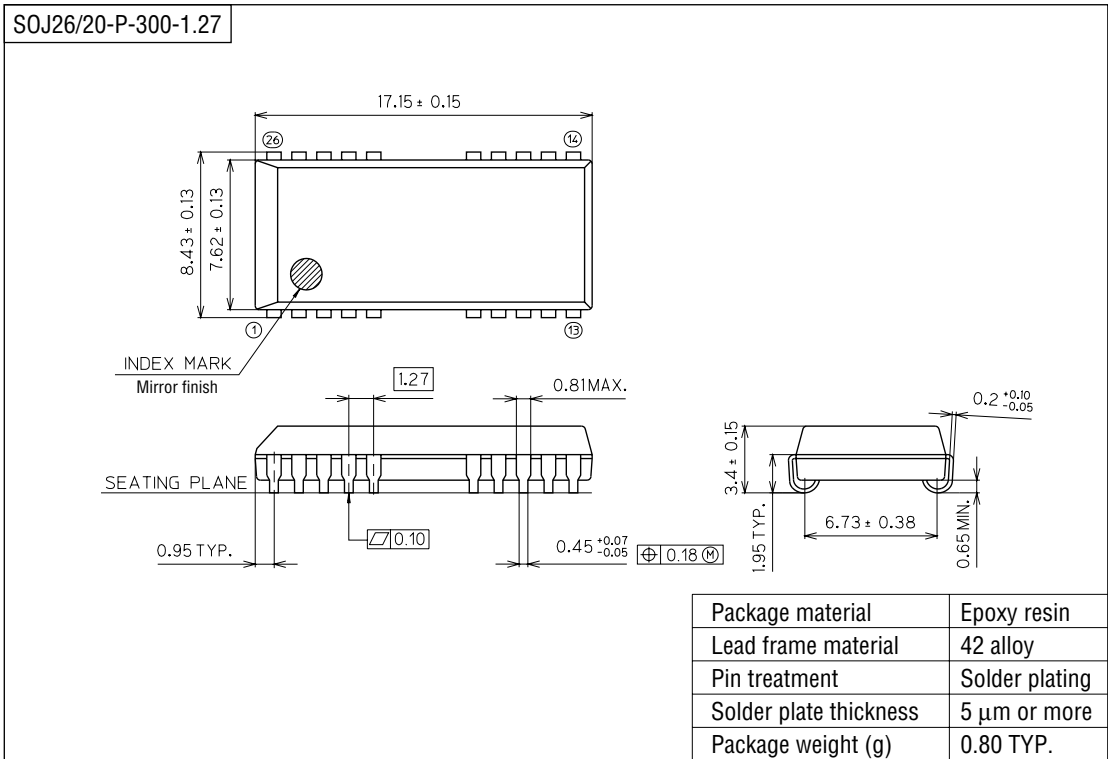

Notes for Mounting the Surface Mount Type Package

The SOP, QFP, TSOP, TQFP, LQFP, SOJ, QFJ (PLCC), SHP, and BGA are surface mount type packages, which are very susceptible to heat in reflow mounting and humidity absorbed in storage. Therefore, before you perform reflow mounting, contact Oki's responsible sales person on the product name, package name, pin number, package code and desired mounting conditions (reflow method, temperature and times).

NOTICE

1. The information contained herein can change without notice owing to product and/or technical improvements. Before using the product, please make sure that the information being referred to is up-to-date.
2. The outline of action and examples for application circuits described herein have been chosen as an explanation for the standard action and performance of the product. When planning to use the product, please ensure that the external conditions are reflected in the actual circuit, assembly, and program designs.
3. When designing your product, please use our product below the specified maximum ratings and within the specified operating ranges including, but not limited to, operating voltage, power dissipation, and operating temperature.
4. Oki assumes no responsibility or liability whatsoever for any failure or unusual or unexpected operation resulting from misuse, neglect, improper installation, repair, alteration or accident, improper handling, or unusual physical or electrical stress including, but not limited to, exposure to parameters beyond the specified maximum ratings or operation outside the specified operating range.
5. Neither indemnity against nor license of a third party's industrial and intellectual property right, etc. is granted by us in connection with the use of the product and/or the information and drawings contained herein. No responsibility is assumed by us for any infringement of a third party's right which may result from the use thereof.
6. The products listed in this document are intended for use in general electronics equipment for commercial applications (e.g., office automation, communication equipment, measurement equipment, consumer electronics, etc.). These products are not authorized for use in any system or application that requires special or enhanced quality and reliability characteristics nor in any system or application where the failure of such system or application may result in the loss or damage of property, or death or injury to humans. Such applications include, but are not limited to, traffic and automotive equipment, safety devices, aerospace equipment, nuclear power control, medical equipment, and life-support systems.
7. Certain products in this document may need government approval before they can be exported to particular countries. The purchaser assumes the responsibility of determining the legality of export of these products and will take appropriate and necessary steps at their own expense for these.
8. No part of the contents contained herein may be reprinted or reproduced without our prior permission.
9. MS-DOS is a registered trademark of Microsoft Corporation.

Copyright 1999 Oki Electric Industry Co., Ltd.