

OKI Semiconductor

FEDL9811FULL-04

Issue Date: Sep. 1, 2004

MSM9811

4-Channel Mixing OKI ADPCM Type Voice Synthesis LSI

GENERAL DESCRIPTION

The MSM9811 is a 4-channel mixing voice synthesis LSI, to which up to 128 Mbits of ROM and/or EPROM storing voice data can directly be connected externally.

The device is straight 8-bit PCM playback, non-linear 8-bit PCM playback, 4-bit ADPCM playback, and 4-bit ADPCM2 playback selectable and provides 2-channel stereo output and volume control. The MSM9811 contains a 14-bit D/A converter and LPF.

The MSM9811 can easily configure a system by connecting voice data storage memory, power amplifier, and CPU externally.

FEATURES

- Non-linear 8-bit PCM/straight 8-bit PCM/4-bit ADPCM/4-bit ADPCM2
- Serial input or parallel input selectable
- Phrase Control Table function
- 4-channel mixing function
- Master clock frequency : 4.096 MHz
- Sampling frequency : 4.0 kHz, 5.3 kHz, 6.4 kHz, 8.0 kHz, 10.6 kHz, 12.8 kHz, 16.0 kHz, 21.2 kHz, 25.6 kHz, 32.0 kHz
- Maximum number of phrases : 256
- Output channel : L/R 2 channels
- Built-in volume control function (for each output channel)
- Built-in 14-bit D/A converter
- Built-in low-pass filter : Digital filter
- Package : 64-pin plastic QFP (QFP64-P-1414-0.80-BK) (MSM9811GA)

PIN CONFIGURATION (TOP VIEW)

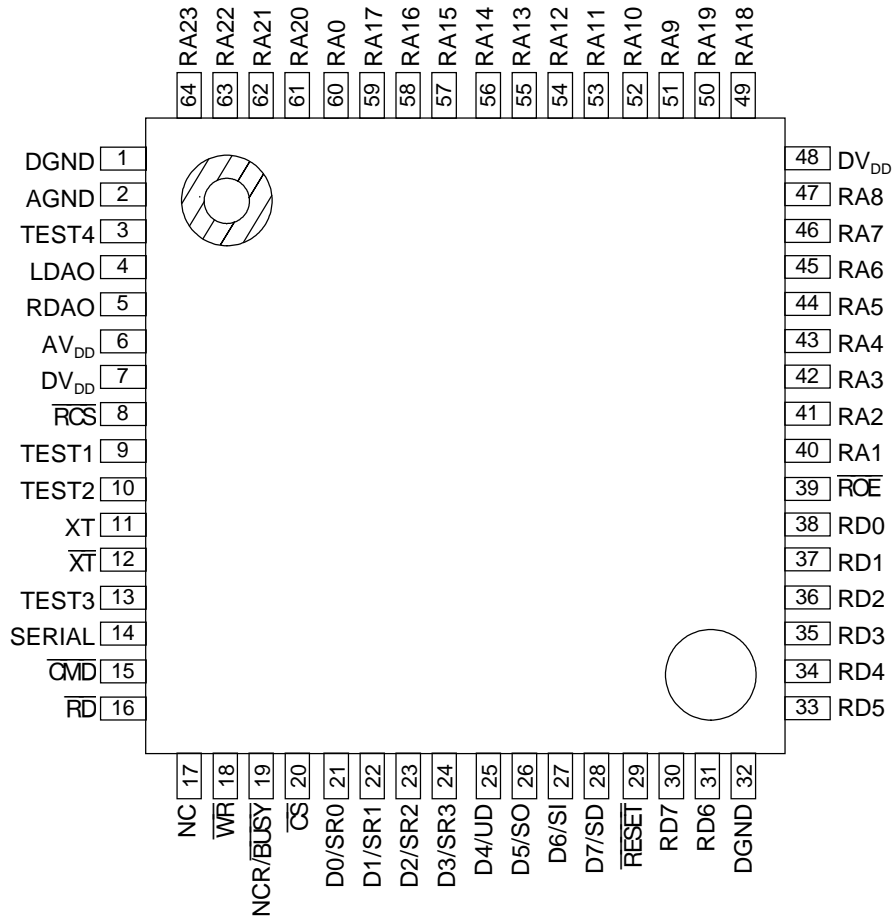

NC: No connection

64-pin Plastic QFP

PIN DESCRIPTIONS

Pin	Symbol	Type	Description
40-47, 49-64	RA23-RA0	O	Address pins for external memory. These pins become high impedance when \overline{RCS} pin is "H".
30, 31, 33-38	RD7-RD0	I	Data pin for external memory. Pull-down resistors are internally connected to these pins. These pull-down resistors become valid when the \overline{RCS} pin is "H", and become invalid when the \overline{RCS} pin is "L".
39	\overline{ROE}	O	Output enable pin for external memory. This pin becomes high impedance when \overline{RCS} pin is "H".
8	\overline{RCS}	I	When this pin is "L", RA23 to RA0 and \overline{ROE} pins output address data and output enable signal. When this pin is "H", RA23 to RA0 and \overline{ROE} pins become high impedance.
15	\overline{CMD}	I	Select pin for Command data or Subcommand data for CPU interface. When this pin is "H", subcommand input is selected. When this pin is "L", command input is selected. A pull-up resistor is internally connected to this pin.
16	\overline{RD}	I	Read pin for CPU interface. A pull-up resistor is internally connected to this pin.
18	\overline{WR}	I	Write pin for CPU interface. A pull-up resistor is internally connected to this pin.
20	\overline{CS}	I	Chip select pin for CPU interface. When \overline{CS} is "H", \overline{WR} signal is not entered in this LSI. A pull-up resistor is internally connected to this pin.
14	SERIAL	I	CPU input interface select pin. When SERIAL is "H", serial input interface is selected. When it is "L", parallel input interface is selected.
28	D7/SD	I/O	Data bus pin for CPU interface when parallel input interface is selected. When \overline{WR} is "L", this pin serves as data input pin. When \overline{RD} is "L", this pin serves as channel status data output pin. When serial input interface is selected, this pin serves as serial data input pin.
27	D6/SI	I/O	Data bus pin for CPU interface when parallel input interface is selected. When \overline{WR} is "L", this pin serves as data input pin. When \overline{RD} is "L", this pin serves as channel status output pin. When serial input interface is selected, this pin serves as serial clock input pin.
26	D5/SO	I/O	Data bus pin for CPU interface when parallel input interface is selected. When \overline{WR} is "L", this pin serves as data input pin. When \overline{RD} is "L", this pin serves as channel status output pin. When serial input interface is selected, this pin serves as channel status serial output pin.

Pin	Symbol	Type	Description
25	D4/UD	I/O	Data bus pin for CPU interface when parallel interface is selected. When \overline{WR} is "L", this pin serves as data input pin. When \overline{RD} is "L", this pin serves as channel status output pin. When serial input interface is selected, fix this pin at GND level.
24	D3/SR3	I/O	Data bus pin for CPU interface when parallel input interface is selected. When \overline{WR} is "L", this pin serves as data input pin. When \overline{RD} is "L", this pin serves as channel status output pin. When serial input interface is selected, this pin serves as channel status output pin. Channels 4 thru 1 are output to SR3 thru SR0, respectively.
23	D2/SR2		
22	D1/SR1		
21	D0/SR0		
4	LDAO	O	LEFT side D/A output pin.
5	RDAO	O	RIGHT side D/A output pin.
11	XT	I	Crystal or ceramic oscillator connection pin. A feedback resistor of about $1M\Omega$ is connected between XT and \overline{XT} . If necessary, enter external clocks into this pin.
12	\overline{XT}	O	Crystal or ceramic oscillator connection pin. When external clocks are used, leave this pin open.
29	\overline{RESET}	I	When this pin is "L" level, the LSI is initialized. At that time, oscillation stops and D/A outputs go to GND level.
19	NCR/ \overline{BUSY}	I	Channel status select pin. When this pin is "H", NCR signal is output. When it is "L", \overline{BUSY} signal is output.
9	TEST1	I	Pins for LSI testing. Apply "L" level to these pins.
10	TEST2		
13	TEST3		
3	TEST4		
7, 48	DV _{DD}	—	Digital power supply pin. A bypass capacitor of 0.1 μ F or more should be connected between the DGND pin and the DV _{DD} pin.
6	AV _{DD}	—	Analog power supply pin. A bypass capacitor of 0.1 μ F or more should be connected between the AGND pin and the AV _{DD} pin.
1, 32	DGND	—	Digital GND pin.
2	AGND	—	Analog GND pin.

ABSOLUTE MAXIMUM RATINGS

(GND = 0 V)

Parameter	Symbol	Condition	Rating	Unit
Power Supply Voltage	V_{DD}	$T_a = 25^\circ\text{C}$	-0.3 to +7.0	V
Input Voltage	V_{IN}		-0.3 to $V_{DD} + 0.3$	V
Storage Temperature	T_{STG}	—	-55 to +150	$^\circ\text{C}$

RECOMMENDED OPERATING CONDITIONS

(GND = 0 V)

Parameter	Symbol	Condition	Range			Unit
Power Supply Voltage	V_{DD}	—	4.5 to 5.5			V
Operating Temperature	T_{op}	—	-40 to +85			$^\circ\text{C}$
Master Clock Frequency	f_{OSC}	—	Min.	Typ.	Max.	MHz
			3.5	4.096	4.5	

ELECTRICAL CHARACTERISTICS**DC Characteristics**(DV_{DD} = AV_{DD} = 4.5 to 5.5 V, DGND = AGND = 0 V, T_a = -40 to +85 $^\circ\text{C}$)

Parameter	Symbol	Condition	Min.	Typ.	Max.	Unit
High-level Input Voltage	V_{IH}	—	$0.84 \times V_{DD}$	—	—	V
Low-level Input Voltage	V_{IL}	—	—	—	$0.16 \times V_{DD}$	V
High-level Output Voltage	V_{OH}	$I_{OH} = -1 \text{ mA}$	$V_{DD} - 0.4$	—	—	V
Low-level Output Voltage	V_{OL}	$I_{OL} = 2 \text{ mA}$	—	—	0.4	V
High-level Input Current 1	I_{IH1}	$V_{IH} = V_{DD}$	—	—	10	μA
High-level Input Current 2 (Note 1)	I_{IH2}	Applied to pins with internal pull-down resistor	30	—	300	μA
Low-level Input Current 1	I_{IL1}	$V_{IL} = \text{GND}$	-10	—	—	μA
Low-level Input Current 2 (Note 2)	I_{IL2}	Applied to pins with internal pull-up resistor	-300	—	-30	μA
Output Leakage Current	I_{LO}	$0 \leq V_{OUT} \leq V_{DD}$	-10	—	+10	μA
Operating Current	I_{DD}	$f_{OSC} = 4 \text{ MHz}$, No load	—	6	15	mA
Standby Current	I_{DS}	$T_a = -40 \text{ to } +70^\circ\text{C}$	—	—	15	μA
		$T_a = -40 \text{ to } +85^\circ\text{C}$	—	—	50	μA

Notes 1: Applicable to RD7 to RD0 pins (when $\overline{\text{RCS}} = \text{"H"}$).

2: Applicable to CMD, RD, WR, and CS pins.

Analog Characteristics(DV_{DD} = AV_{DD} = 4.5 to 5.5 V, DGND = AGND = 0 V, Ta = -40 to +85°C)

Parameter	Symbol	Condition	Min.	Typ.	Max.	Unit
LDAO,RDAO Load Resistance (During OP amplifier output)	R _{OUTA}	—	50	—	—	kΩ
LDAO,RDAO Output Impedance (When OP amplifier is not used)	R _{OUTD}	—	—	3	—	kΩ
LDAO,RDAO Output Level	—	No load	—	0.7 to 0.94 V _{DD}	—	V

AC Characteristics(V_{DD} = 4.5 to 5.5 V, GND = 0 V, Ta = -40 to +85°C, C_L = 5 pF)

Parameter	Symbol	Min.	Typ.	Max.	Unit
Master Clock Duty Cycle	f _{duty}	40	50	60	%
RESET Input Pulse Width	t _{w(RST)}	1	—	—	μs
RESET Delay Time From Raising of Power Supply	t _{D(RST)}	0	—	—	μs
Set up and Hold Time of \overline{CS} for \overline{RD}	t _{CR}	30	—	—	ns
\overline{RD} Pulse Width	t _{RR}	200	—	—	ns
Output Data Valid Time after Fall of \overline{RD}	t _{DRE}	—	—	100	ns
Data Float Time after Rise of \overline{RD}	t _{DRF}	—	10	50	ns
Setup and Hold Time of \overline{CMD} for \overline{WR}	t _{DW}	50	—	—	ns
Setup and Hold Time of \overline{CS} for \overline{WR}	t _{CW}	30	—	—	ns
\overline{WR} Pulse Width	t _{WW}	200	—	—	ns
Data Setup Time before Rise of \overline{WR}	t _{DWS}	100	—	—	ns
Data Hold Time after Rise of \overline{WR}	t _{DWH}	30	—	—	ns
\overline{WR} - \overline{WR} Pulse Interval	t _{WWS}	160	—	—	ns
\overline{CS} - \overline{CS} Pulse Interval	t _{CC}	100	—	—	ns
Serial Data Setup Time	t _{SDS}	30	—	—	ns
Serial Data Hold Time	t _{SSD}	30	—	—	ns
Serial Clock Pulse Width	t _{w(SCK)}	200	—	—	ns
Output Data Valid Time after Rise of Serial Clock	t _{SDD}	—	—	200	ns
Setup Time of \overline{WR} for Serial Data	t _{SWDS}	200	—	—	ns
Setup Time of Serial Clock Fall for \overline{WR} Rise	t _{SIWS}	300	—	—	ns
Setup Time of \overline{RD} for Serial Clock Rise	t _{SRIS}	300	—	—	ns

TIMING DIAGRAMS (PARALLEL INPUT)

Data Read Timing

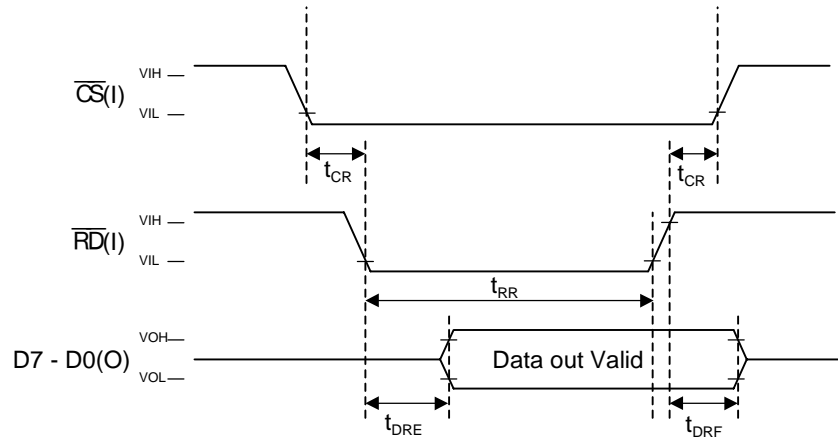

Data Write Timing (Sub-command, Command Input)

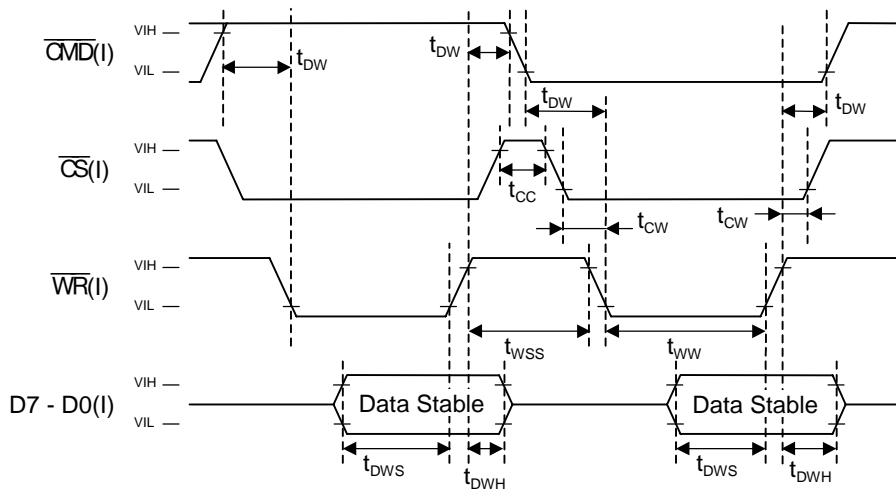

TIMING DIAGRAMS (SERIAL INPUT)

Data Write Timing (Sub-command, Command Input)

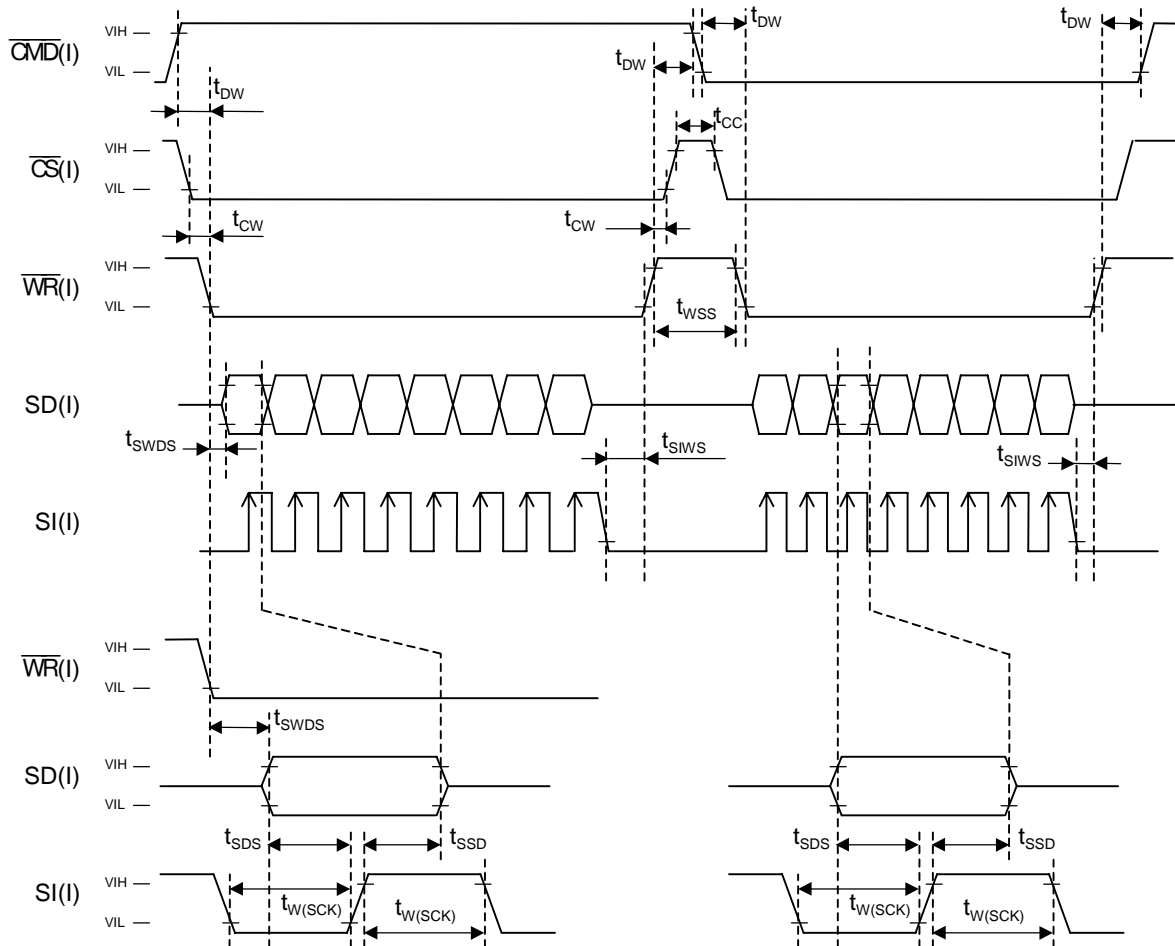

Data Read Timing

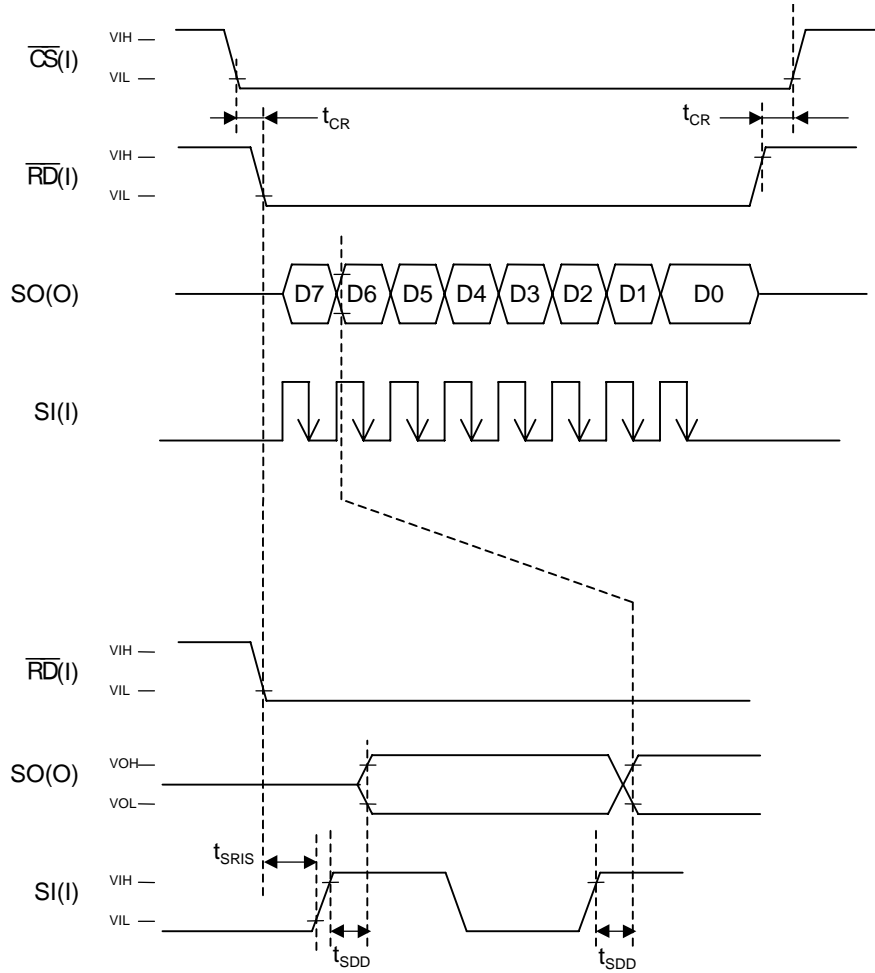

TIMING DIAGRAM (COMMON TO PARALLEL AND SERIAL I/O)

Power-on Timing · Power-down Timing

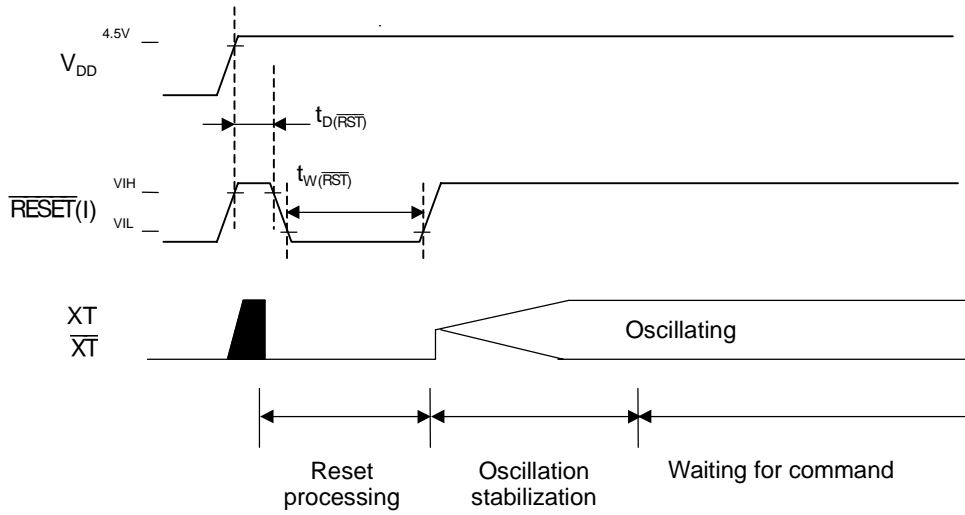

Standby

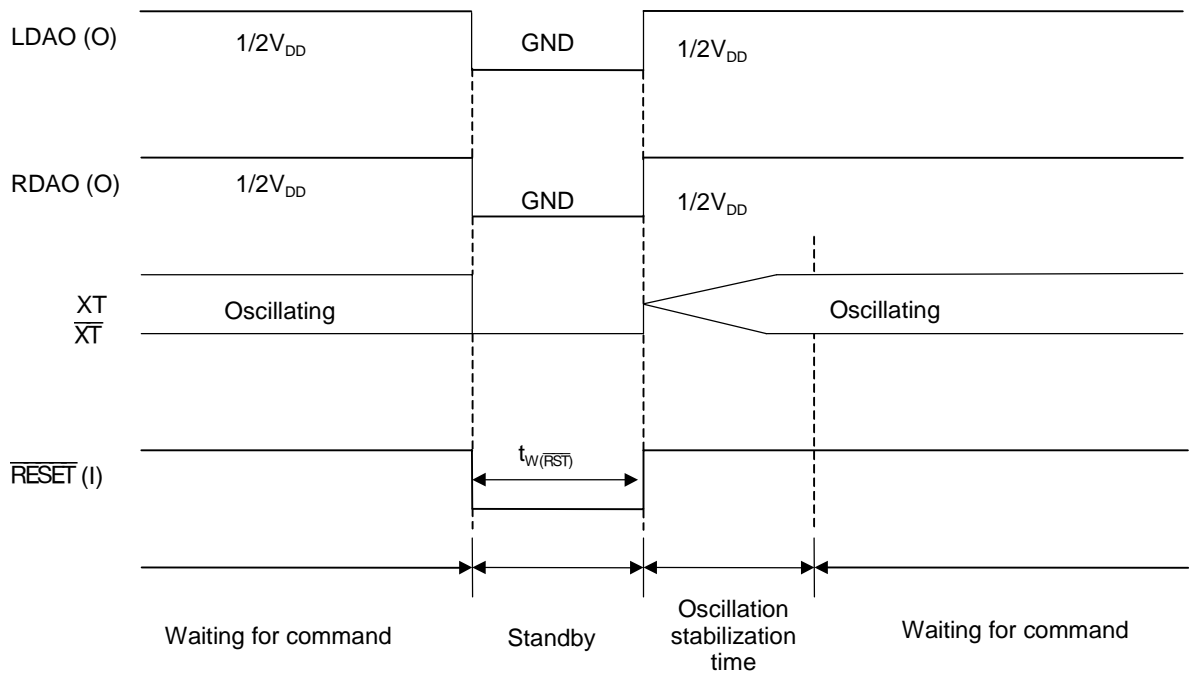

Continuous Playback Timing When Phrase Control Table is not Used

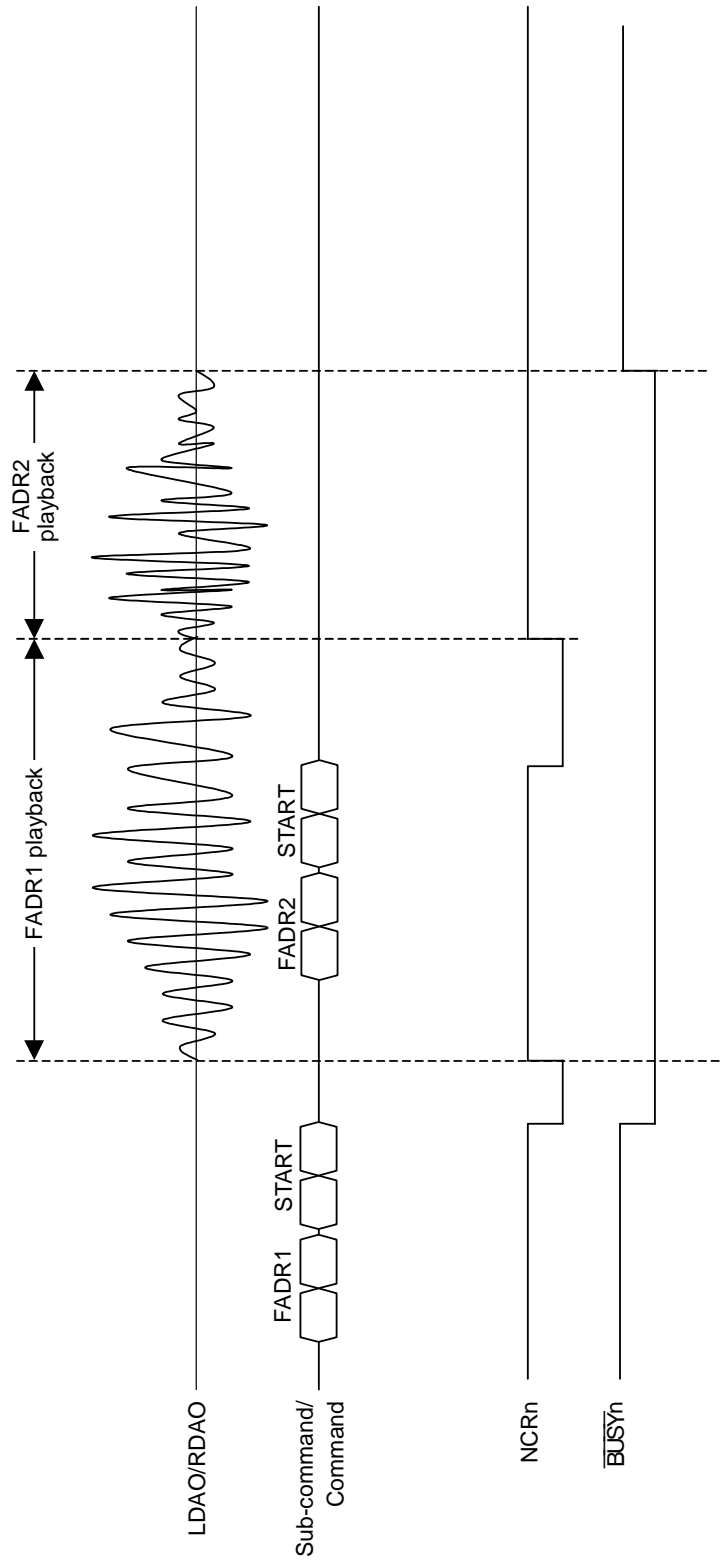

Continuous Playback Timing When Phrase Control Table is Used

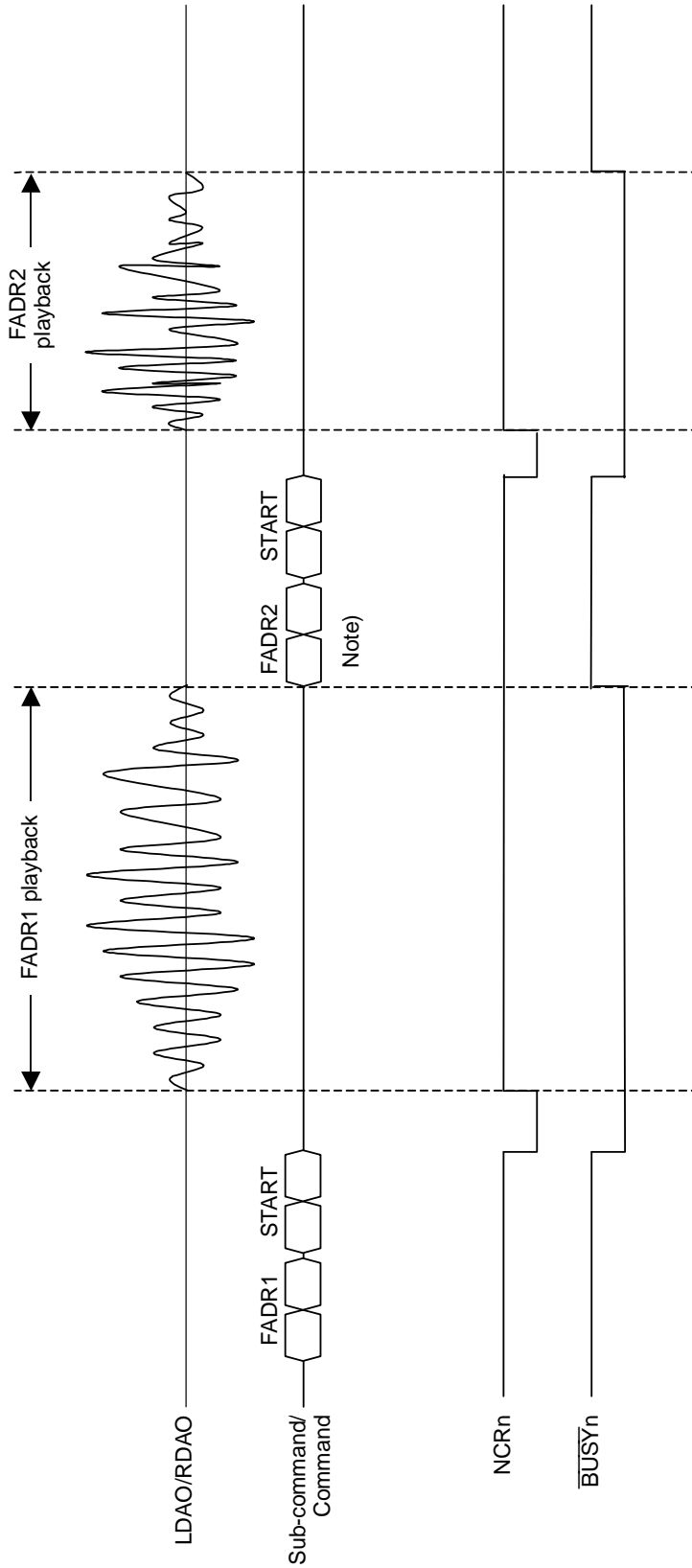

(Note)
Do not enter the **START** command and **MUON** command during playback (**BUSY** = "L") when the phrase control table is used. Otherwise, the LSI may malfunction. Enter the **START** command and **MUON** command after **BUSY** = "H".

LOOP Playback Timing (Phrase Control Table is Used/not Used)

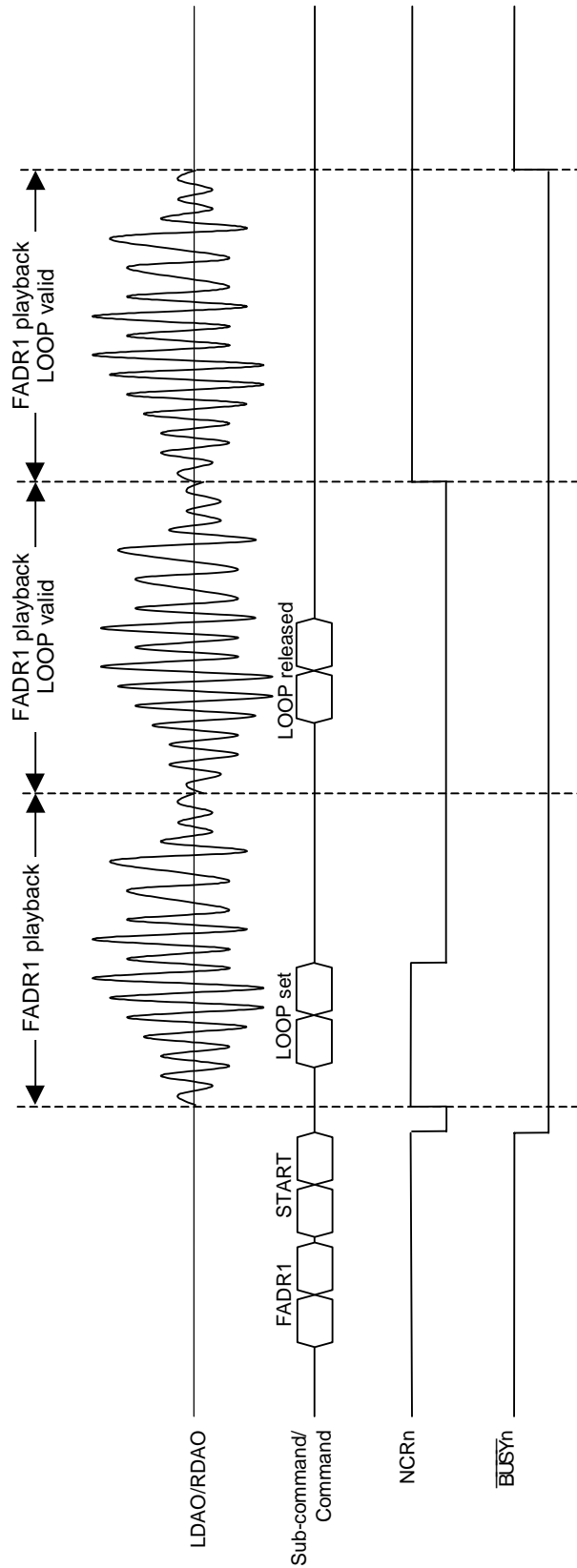

MUON Command Input Timing When Phrase Control Table is not Used

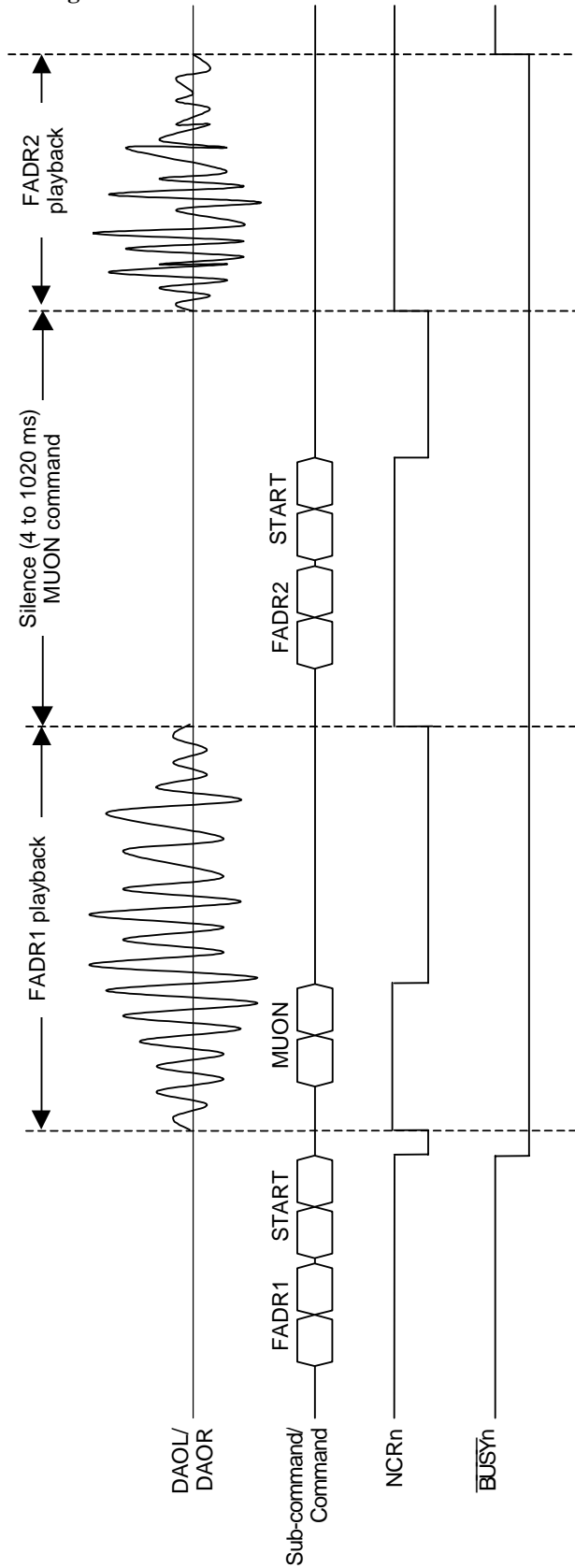

MUON Command Input Timing When Phrase Control Table is Used

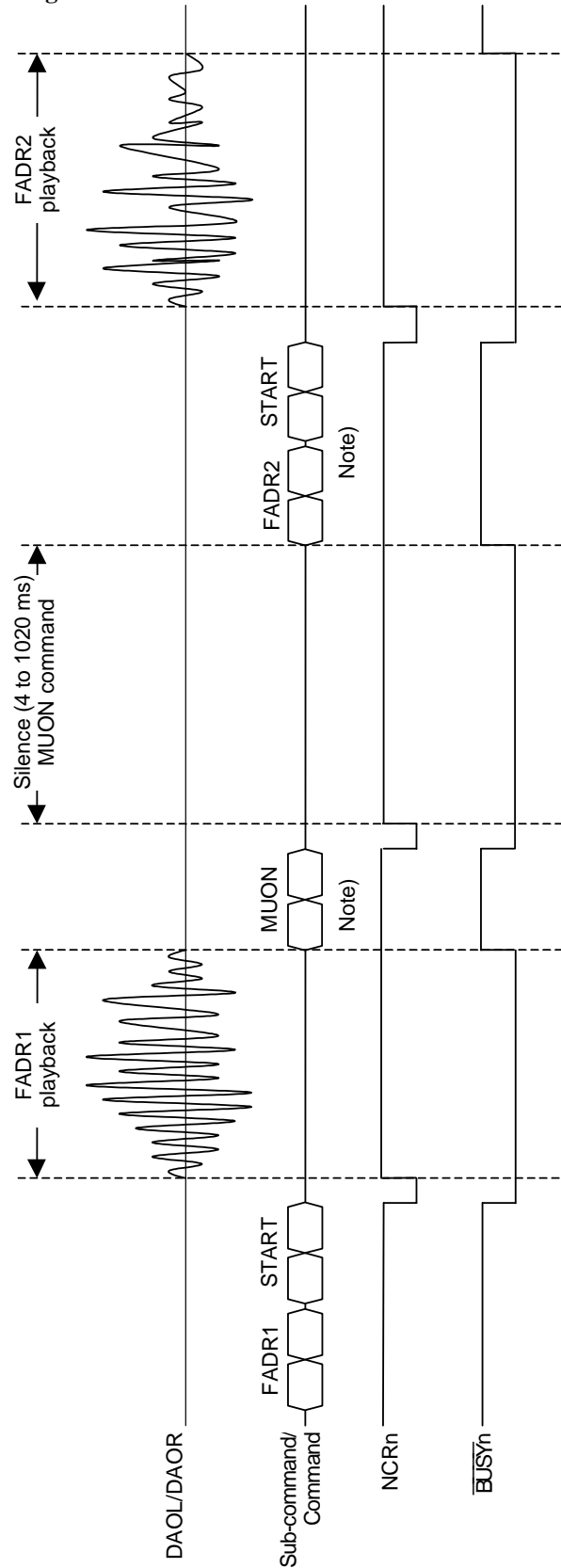

(Note)

Do not enter the START command and MUON command during playback ($\overline{\text{BUSY}} = \text{"L"}$) when the phrase control table is used. Otherwise, the LSI may malfunction. Enter the START command and MUON command after $\overline{\text{BUSY}} = \text{"H"}$.

FUNCTIONAL DESCRIPTION

Microcontroller Interface

The microcontroller interface includes two interface circuits, parallel interface and serial interface. The statuses of each pin both in parallel interface mode and in serial interface mode are shown below.

SERIAL = "L"		SERIAL = "H"	
Parallel I/O interface		Serial I/O interface	
D7 (I/O)	Data I/O pins	SD (I)	Serial data input pin
D6 (I/O)		SI (I)	Serial clock input pin
D5 (I/O)		SO (O)	Serial data output pin
D4 (I/O)		UD (I)	Fix this pin at GND level
D3 (I/O)		SR3 (O)	Channel status signal output pin
D2 (I/O)		SR2 (O)	
D1 (I/O)		SR1 (O)	
D0 (I/O)		SR0 (O)	

Command List

Commands

Each command consists of a command and a sub-command.

Data is input when the CMD pin is "H". A command is input when the CMD pin is "L".

NCRn	Command name	CMD pin	D7 to D0								Description	
			7	6	5	4	3	2	1	0		
Valid only at "H"	START	H	0	0	0	0	CH4 to CH1				Sets the bit of a voice synthesis start channel to "1".	
		L	0	0	0	0	0	X	X	X	Starts playback.	
None	STOP	H	0	0	0	0	CH4 to CH1				Sets the bit of a voice synthesis end channel to "1".	
		L	0	0	0	0	1	X	X	X	Ends playback.	
None	LOOP	H	0	0	0	0	CH4 to CH1				Sets the bit of a LOOP channel to "1".	
		L	0	0	0	1	0	X	X	X	Starts LOOP.	
None	OPT	H	0	0	0	0	0	0	0	0	00	Selects an option.
		L	0	0	0	1	1	X	X	X		
Valid only at "H"	MUON	H	M7 to M0								Selects a silence time at $M \times 4$ ms. (Condition: $1 \leq M \leq 255$)	
		L	0	0	1	0	0	0	C1 to C0			Selects a channel that outputs a silence and plays a silence.
None	FADR	H	FA7 to FA0								Selects a phrase to be played.	
		L	0	0	1	0	1	0	C1 to C0			Selects a channel that sets up a phrase.
None	DADR	H	SA23 to SA16								Selects a ROM address at which voice synthesis starts.	
		H	SA15 to SA8									
		H	SA7 to SA0									
		H	ST23 to ST16								Selects a ROM address at which voice synthesis ends.	
		H	ST15 to ST8									
		H	ST7 to ST0									
		H	S3 to S0				P1 to P0		0	0	Selects a sampling frequency using S3 to S0. Selects a voice synthesis method using P1 to P0.	
L	0	0	1	1	0	0	C1 to C0			Selects the condition to a channel selected by C1 to C0.		
None	CVOL	H	X	X	X	X	V3 to V0				Sets a playback volume between V3 and $V0 \times -2$ dB.	
		L	0	0	1	1	1	0	C1 to C0			Selects a channel to which a playback volume is set.
None	PAN	H	L3 to L0				R3 to R0				Selects a left side voice volume using L3 to L0 and selects a right side voice volume using R3 to R0. The volume of output is -2 dB \times (L or R).	
		L	0	1	0	0	0	0	C1 to C0			Selects a channel for setting PAN using C1 to C0.

X: Don't Care

Sampling Frequency List

S3 to S0	Sampling Frequency
0	4.0 kHz
1	8.0 kHz
2	16.0 kHz
3	32.0 kHz
4	Undefined
5	6.4 kHz
6	12.8 kHz
7	25.6 kHz
8	Undefined
9	5.3 kHz
10	10.6 kHz
11	21.2 kHz
12	Undefined
13	Undefined
14	Undefined
15	Undefined

Voice Synthesis Algorithm List

P1 to P0	Voice synthesis algorithm
0	OKI 4-bit ADPCM
1	OKI 4-bit ADPCM2
2	8-bit Straight PCM
3	OKI 8-bit Nonlinear PCM

PAN and CVOL List

L3 to L0 R3 to R0 V3 to V0	Volume	L3 to L0 R3 to R0 V3 to V0	Volume
0	0 dB	8	-16 dB
1	-2 dB	9	-18 dB
2	-4 dB	10	-20 dB
3	-6 dB	11	-22 dB
4	-8 dB	12	-24 dB
5	-10 dB	13	-26 dB
6	-12 dB	14	-28 dB
7	-14 dB	15	-30 dB

OPT Command List

Default	O4	O3	O2	O1	O0	Description
*	0	0	x	x	x	Sets the volumes of all channels to V_{DD} (p-p).
	0	1	x	x	x	Sets the volumes of all channels to $1/2 V_{DD}$ (p-p).
	1	0	x	x	x	Sets the volumes of all channels to $1/4 V_{DD}$ (p-p).
	1	1	x	x	x	Sets the volumes of all channels to $1/8 V_{DD}$ (p-p).
*	x	x	0	0	x	Secondary digital filtering is performed.
	x	x	0	1	x	Primary digital filtering is performed.
	x	x	1	x	x	An on-chip digital filter is not used.
*	x	x	x	x	0	Data is output directly from a D/A converter. (Output $Z \cong 3 \text{ k}\Omega$)
	x	x	x	x	1	Data is output via a voltage follower. (Output $Z \cong 500 \Omega$)

(Note) x indicates that data is independent of a function described.

LPF Frequency Characteristics

This LSI contains a LPF in which a digital filter technology is used. The frequency characteristics when a secondary filter is used at $f_s = 8$ kHz is shown below. The cutoff frequency is directly proportional to the sampling frequency f_s .

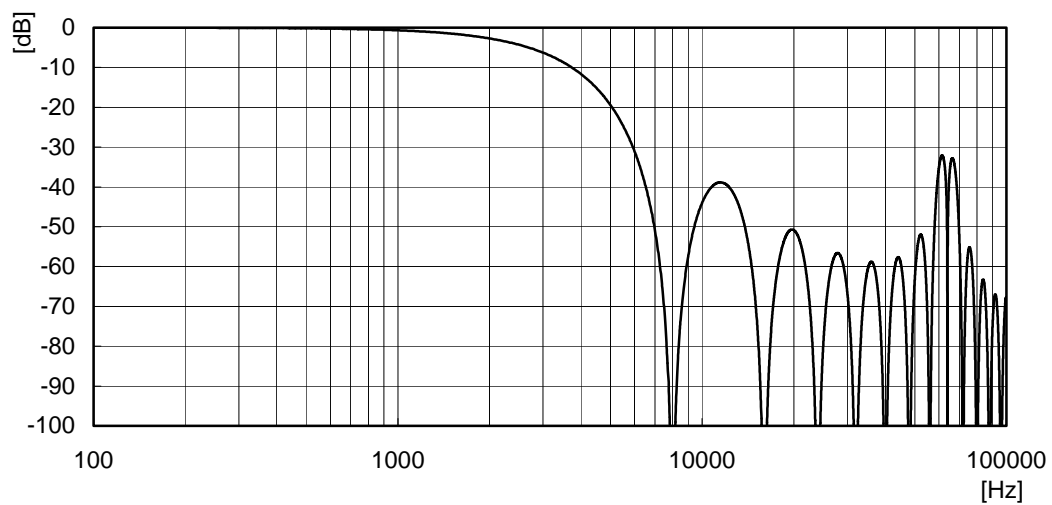

LPF Output Frequency Characteristics ($f_s = 8$ kHz)

Power Down Function

To enter the power down mode, set the RESET pin to “L”.

When an external clock is supplied to the XT pin, fix the XT pin at “L”.

If an external clock is supplied via the XT pin during the power down mode, the I_{DS} specification is not satisfied because current flows between the XT pin and the \overline{XT} pin.

The circuit of XT and \overline{XT} pins is shown below.

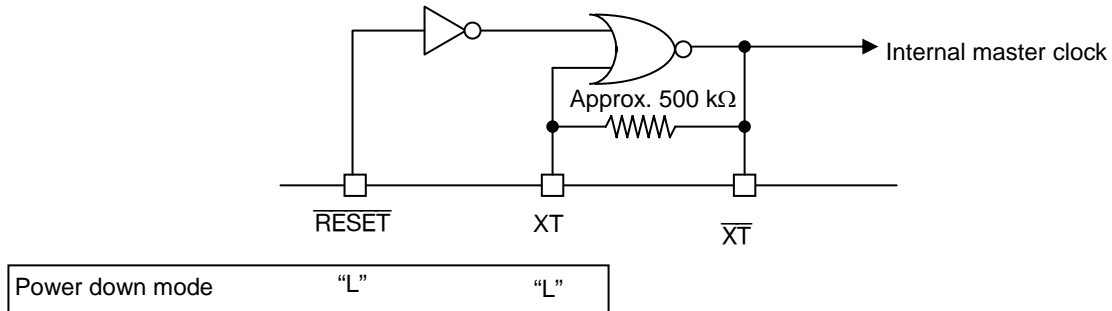

Channel Status

The channel status includes NCR_n and BUSY_n. These two channel statuses can be switched by setting the NCR/BUSY pin.

Corresponding channel	NCR/BUSY = “H”	NCR/BUSY = “L”
CH1	NCR1	$\overline{BUSY1}$
CH2	NCR2	$\overline{BUSY2}$
CH3	NCR3	$\overline{BUSY3}$
CH4	NCR4	$\overline{BUSY4}$

The n-channel NCR signal is NCR_n and the n-channel BUSY signal is BUSY_n.

When NCR_n is “H”, the START command and MUON command can be input for the next message of “n” channel to be played.

When the phrase control table is used and BUSY_n is “L”, do not enter the START command and MUON command even if NCR_n is “H”.

Otherwise, the LSI may malfunction.

When BUSY_n is “H”, the “n” channel does not output a voice.

When BUSY_n is “L”, the “n” channel outputs a voice.

Parallel I/O (SERIAL = "L")

The outputs of channel statuses in parallel I/O mode are shown below.

Pin name	NCR/ $\overline{\text{BUSY}}$ = "H"	NCR/ $\overline{\text{BUSY}}$ = "L"
D3	NCR4	$\overline{\text{BUSY4}}$
D2	NCR3	$\overline{\text{BUSY3}}$
D1	NCR2	$\overline{\text{BUSY2}}$
D0	NCR1	$\overline{\text{BUSY1}}$

Serial I/O (SERIAL = "H")

The outputs when channel statuses are serially read during serial I/O mode are shown below.

Signal name	NCR/ $\overline{\text{BUSY}}$ = "H"	NCR/ $\overline{\text{BUSY}}$ = "L"
SO3	NCR4	$\overline{\text{BUSY4}}$
SO2	NCR3	$\overline{\text{BUSY3}}$
SO1	NCR2	$\overline{\text{BUSY2}}$
SO0	NCR1	$\overline{\text{BUSY1}}$

The outputs when channel statuses are output via SR3 to SR0 during serial I/O mode are shown below.

Pin name	NCR/ $\overline{\text{BUSY}}$ = "H"	NCR/ $\overline{\text{BUSY}}$ = "L"
SR3	NCR4	$\overline{\text{BUSY4}}$
SR2	NCR3	$\overline{\text{BUSY3}}$
SR1	NCR2	$\overline{\text{BUSY2}}$
SR0	NCR1	$\overline{\text{BUSY1}}$

Voice Synthesis Algorithms

The MSM9811 contains 4-bit ADPCM algorithm, 4-bit ADPCM2 algorithm, 8-bit straight PCM algorithm, and 8-bit non-linear PCM algorithm. One of these algorithms can be selected depending on the kind of voices to be played. The features of these algorithms are described below.

Voice synthesis algorithm	Applicable waveform	Feature
Oki 4-bit ADPCM	Normal voice waveforms	Oki-original 4-bit ADPCM
Oki 4-bit ADPCM2	Normal voice waveforms	An improved version of Oki-original 4-bit ADPCM. This algorithm has improved its waveform traceability.
Oki 8-bit Nonlinear PCM	Sound effects including high frequency components	This algorithm plays back the center of waveform as a 10-bit sound.
8-bit PCM	Sound effects including high frequency components	Normal 8-bit PCM algorithm

Memory Configuration and Voice Data Creation Method

The ROM data consists of a voice management area, a voice data area, and a phrase control table area.

The voice management area controls the voice data start address, voice data end address, and use of the phrase control table.

256 phrases of voice management data are stored in this area.

The voice data area stores actual waveform data.

The phrase control table area stores data for effectively using voice data. See "Phrase Control Table Function" for details.

The ROM data is created by using a dedicated tool.

ROM address	
0x000000	Voice management area (16 Kbit fixed)
0x0007FF	
0x000800	Voice data area
max: 0x7fffff	
max: 0x7fffff	Phrase control table area This area is used to create ROM data.

Playback Time and Memory Capacity

The playback time is determined by external memory capacity, sampling frequency, and voice synthesis algorithm. The relationship is described below.

$$\text{Playback time} = \frac{1.024 \times (\text{Memory capacity} - 16) \text{ (Kbits)}}{\text{Sampling frequency (kHz)} \times \text{bit length}} \quad (\text{Seconds})$$

(The bit length is 4 bits for ADPCM and ADPCM2 and 8 bits for PCM.)

When the sampling frequency is 16 kHz and the voice synthesis algorithm is 4-bit ADPCM and an 8-Mbit ROM is used, the playback time is calculated as shown below.

$$\text{Playback time} = \frac{1.024 \times (8192 - 16) \text{ (Kbits)}}{16 \text{ (kHz)} \times 4 \text{ (bit)}} \cong 131 \text{ (Seconds)}$$

In the above equation, the playback time when the phrase control table function is not used is shown.

Mixing Function

It is possible to mix 4 channels at a time. Moreover, the LSI is capable of starting or stopping voices of each channel separately.

- Note on waveform clamping during mixing
Increasing the number of channels to be mixed may cause clamping.
To prevent clamping, reduce the volumes of all channels using the OPT command.

(Note)

Mixing using a different sampling frequency cannot be done.

Continuous Playback Function

The continuous playback function is used to continuously play back the next phrase after playing back a phrase. The next phrase to be played can be previously selected while a phrase is being played back. See “Continuous Playback Flowchart” for details.

The continuous playback function is also available in the case of the phase control table.

(Note)

The following changes of voice synthesis algorithms are not permitted for continuous playback function. These changes may generate noises.

- ADPCM → ADPCM2
- ADPCM2 → ADPCM

Phrase Control Table Function

The phrase control table function is used to continuously play back multiple phrases and to set up a volume. It is possible to perform the following functions using the phrase control table function.

- CVOL setting
- Continuous playback (The number of continuous playbacks can be specified limitlessly, but depends on memory capacity.)
- Silence insertion function (4 mSec to 124 mSec)

The memory capacity of voice ROM is effectively used by using the phrase control table function. Examples of ROM data when the phrase control table function is used are shown below.

Example 1) Phrases when the phrase control table function is used

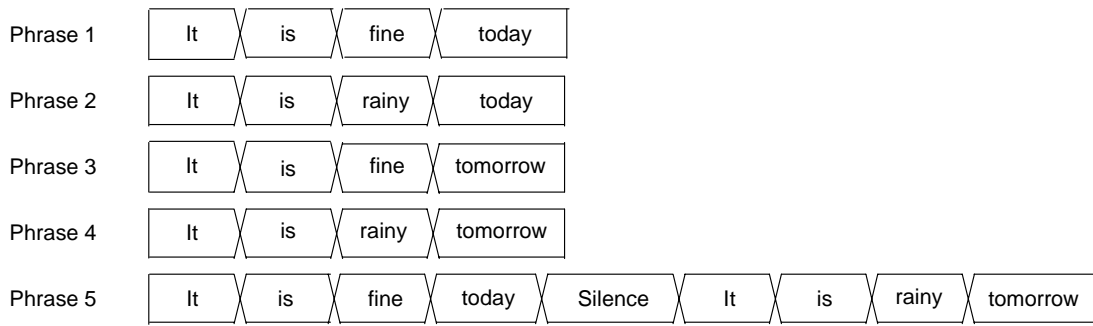

Example 2) ROM data when the example 1 is converted into ROM

Address management area	
It	
fine	rainy
is	today
tomorrow	
Phrase control area	

(Note)

In the phrase control table, each message of the playing phrase is provided with a CVOL value. Note that a CVOL value is overwritten over each message.

Volume Function

- A volume can be adjusted at the stages of OPT, CVOL and PAN as shown below.
- A volume is set to all channels at the stage of OPT.
- A volume is set to each channel at the stage of CVOL.
- A volume is set to “L” and “R” of each channel at the stage of PAN.

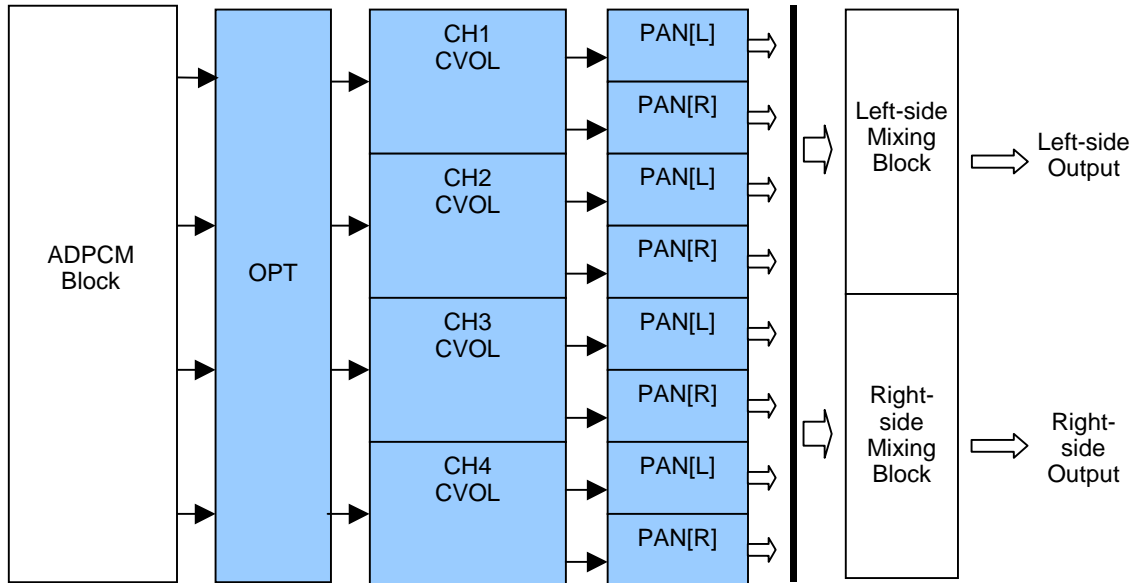

The output level attenuations when the CVOL, OPT and PAN commands are executed are shown below.

<Left-side output volume calculation>

Left-side output volume = $(V + L) \times -2 + (O4 \times 2 + O3) \times -6$ [dB]

V: Setting a volume (0 to 15) with the CVOL command

L: Setting a left-side volume (0 to 15) with the PAN command

O4, O3: Setting a volume (0 or 1) with the OPT command

<Right-side output volume calculation>

Right-side output volume = $(V + L) \times -2 + (O4 \times 2 + O3) \times -6$ [dB]

V: Setting a volume (0 to 15) with the CVOL command

L: Setting a right-side volume (0 to 15) with the PAN command

O4, O3: Setting a volume (0 or 1) with the OPT command

START Command

The START command starts voice synthesis of the channel corresponding to the data stored in the TMP register. Table 1 shows the correspondence between data input (D7-D0) and channels. In the case of serial input, all 8 bits of D7 to D0 should be input serially from MSB.

Table 1 Correspondence between D7-D0 and Channels

Data bus	D7	D6	D5	D4	D3	D2	D1	D0
Corresponding channel	0	0	0	0	CH4	CH3	CH2	CH1

When the START command is input, data stored in the TMP register is set at the start register, and voice synthesis processing starts. For example, when all "1's" are written from the data bus to the TMP register and the START command is input, all channels start voice synthesis simultaneously.

Input the START command when the status signal (NCR or BUSY) of the channel to be started is at "H". When NCR is "L", input is disabled. When the phrase control table is used, input the START command while BUSY is "H". Otherwise, the LSI may malfunction.

Figure 4 shows the flowchart when the START command is input.

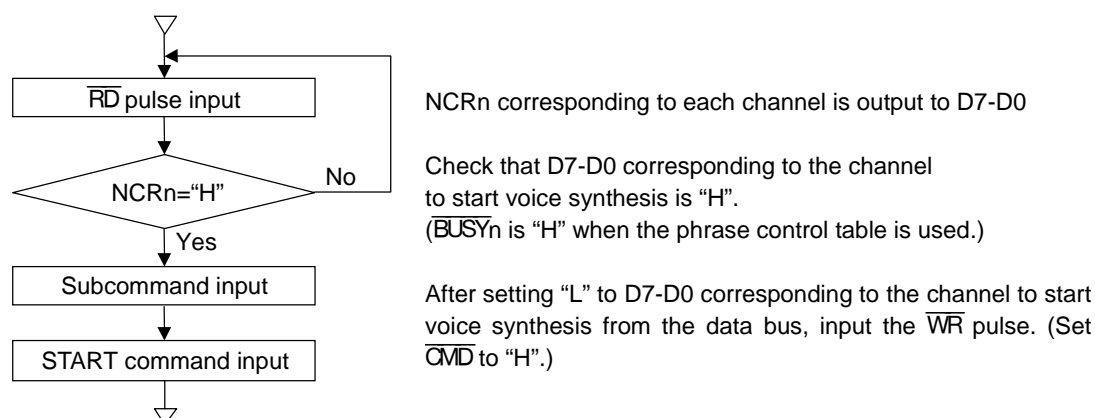

Figure 4 START Command Input Flow

STOP Command

The STOP command stops voice synthesis processing of the channel corresponding to data stored in the TMP register. Table 2 shows the correspondence between data input (D7-D0) and channels.

Table 2 Correspondence between D7-D0 and channels

Data bus	D7	D6	D5	D4	D3	D2	D1	D0
Corresponding channel	0	0	0	0	CH4	CH3	CH2	CH1

When the STOP command is input, the LSI stops processing of voice synthesis of the corresponding channel at the rise of the WR pulse. When voice synthesis stops, the PCM value of that channel is cleared to $1/2 V_{DD}$, and the NCR and BUSY channel status signals become "H".

When "H" has been set at the START register, the START register is cleared to "L".

LOOP Command

The LOOP command repeats a playback of voice synthesis of the channel corresponding to data stored in the TMP registers. Table 3 shows the correspondence between data input (D7-D0) and channels.

Table 3 Correspondence between D7-D0 and Channels

Data bus	D7	D6	D5	D4	D3	D2	D1	D0
Corresponding channel	0	0	0	0	CH4	CH3	CH2	CH1

When the LOOP command is input, the LSI writes data of the TMP register to the LOOP register at rise of WR pulse, and repeats a playback of the channel where “H” is set. Once “H” is set at the LOOP register, playback continues until “L” is set from the outside. If the phrase control table function has been used for a phrase address, the edited voice is repeatedly played back.

To end a repeating playback, set the register of the channel to end the repeat to “L” using the LOOP command again. When the register is set to “L”, repeating ends with the phrase next to the current playback phrase. If the START register has been set to continue the playback of another phrase, another phrase is played back continuously after repeating ends.

Figure 5 shows an example.

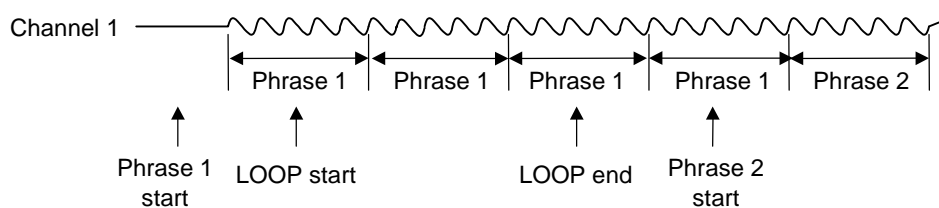

Figure 5 LOOP Command Execution Example

OPT Command

The OPT command changes the setting inside the LSI according to data stored in the TMP register. Table 4 shows the correspondence between data input (D7 to D0) and options.

Table 4 OPT Command List

Default	O4	O3	O2	O1	O0	Description
*	0	0	x	x	x	Sets the volumes of all channels to V_{DD} (p-p).
	0	1	x	x	x	Sets the volumes of all channels to $1/2 V_{DD}$ (p-p).
	1	0	x	x	x	Sets the volumes of all channels to $1/4 V_{DD}$ (p-p).
	1	1	x	x	x	Sets the volumes of all channels to $1/8 V_{DD}$ (p-p).
*	x	x	0	0	x	Secondary digital filtering is performed.
	x	x	0	1	x	Primary digital filtering is performed.
	x	x	1	x	x	An on-chip digital filter is not used.
*	x	x	x	x	0	Data is output directly from a D/A converter. (Output $Z \cong 3 \text{ k}\Omega$)
	x	x	x	x	1	Data is output via a voltage follower. (Output $Z \cong 500 \Omega$)

(Note) x indicates that data is independent of a function described.

When the OPT command is input, the LSI changes the option at the rising edge of the WR pulse. When power is turned on, or when the RESET pulse is input, the registers corresponding to D4-D0 have been set to "L".

If the option is changed when voice synthesis is in execution, voice quality may change. Oki recommends to set the option after power is turned on or after RESET is input.

1) Volume Option

Volume can be set by the CVOL command and PAN command, but a waveform may be clamped when channel synthesis is executed.

If the CVOL command and PAN command are used to prevent a waveform from being clamped, the number of steps used for actual volume decreases, and effective voice synthesis may not be performed.

If it is known that a waveform will be clamped, this option can set the volume of all channels to low, so that the number of steps of the volume can be utilized to the maximum level.

2) Digital Filter Processing

This LSI has a built-in oversampling circuit for digital filter processing. This oversampling system evenly generates four times more points of sampling frequencies.

When power is turned on or if the RESET pulse is input, those pulses have been set to pass through the oversampling circuit. If digital filter processing is unnecessary, change this setting by the OPT command.

3) Analog Output

When power is turned on, it has been set that the output of the D/A converter is output via the voltage follower. To change this setting, use the OPT command.

The output impedance of analog signals being output via the voltage follower is about 500 Ω.

The output impedance of analog signals directly output from the D/A converter is about 3 kΩ.

MUON Command

The MUON command inserts silence into the specified channel at the rise of the WR pulse. The length of silence is according to the size of data stored in the TMP register.

The length of silence data is input in advance, before executing the MUON command. Silence length can be set for 255 steps, 4 ms to 1020 ms, in 4 ms intervals. Silence time can be set as follows.

$$t_{mu} = (2^7 \times (D7) + 2^6 \times (D6) + 2^5 \times (D5) + 2^4 \times (D4) + 2^3 \times (D3) + 2^2 \times (D2) + 2^1 \times (D1) + 2^0 \times (D0)) \times 4.096 \text{ ms}$$

The operation of the MUON command is similar to the START command to start voice synthesis. When the MUON command is input, "H" is set to the START register, and NCR and BUSY signals becomes "L".

If the MUON command is input when voice synthesis is in execution, silence time is inserted after voice synthesis ends.

Input the MUON command when the status signal (NCR or BUSY) of the channel to start voice synthesis is at "H". When NCR is "L", input is disabled. When the phrase control table is used, input the MUON command while BUSY is "H". Otherwise, the LSI may malfunction.

Figure 6 shows a flow chart example when the MUON command is input.

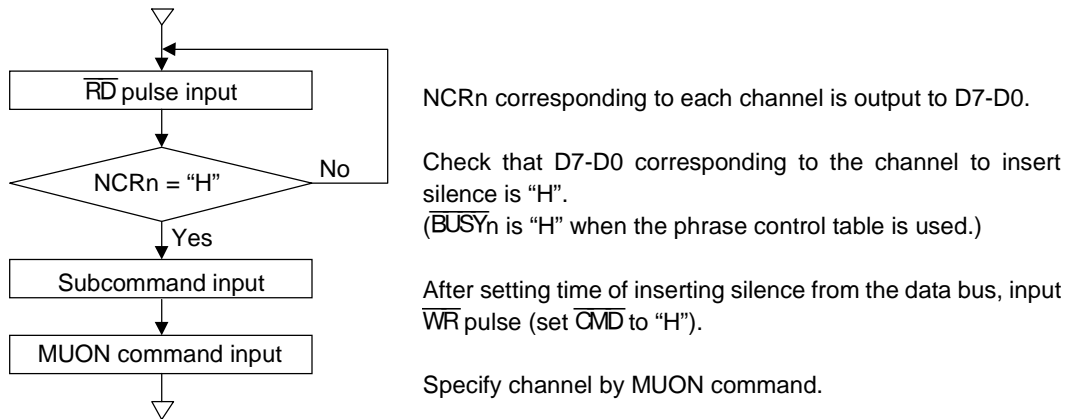

Figure 6 MUON Command Input Flow

FADR Command

The FADR command transfers data stored in the TMP register to the phrase address register of the corresponding channel at the rise of the WR pulse.

For the phrase address, the user specification phrases have been set by an analysis tool, and the playback system, sampling frequency and start and stop address of voice data have been registered to the address management area. When the phrase address is set and the START command is input, the LSI reads data of the address management area, and starts voice synthesis.

Since the phrase address is set by D7-D0, a maximum of 256 phrases can be set. The edit function can be used for phrase addresses, so not only one phrase but combinations with other phrases are possible.

DADR Command

The DADR command transfers data stored in the TMP (1-7) register to the start and stop address register of the corresponding channel at the rise of the WR pulse.

For the direct address, the playback system, sampling frequency, and start and stop addresses of voice data are directly input from the microcomputer without using the address management area.

Direct address playback system is available with channel 1 to 4, and not available with channel 5 to 8.

Since the phrases that can be set at a phrase address is a maximum of 256, if voice data exceeds 256 phrases, use this command. Data on the playback system, sampling frequency, and start and stop address of voice data is displayed when an analysis tool is used.

Data on the playback system, sampling frequency, and start and stop address of voice data is input to the TMP1 to TMP7 registers divided in 7 steps, unlike the data input of other commands.

Figure 7 shows the input method.

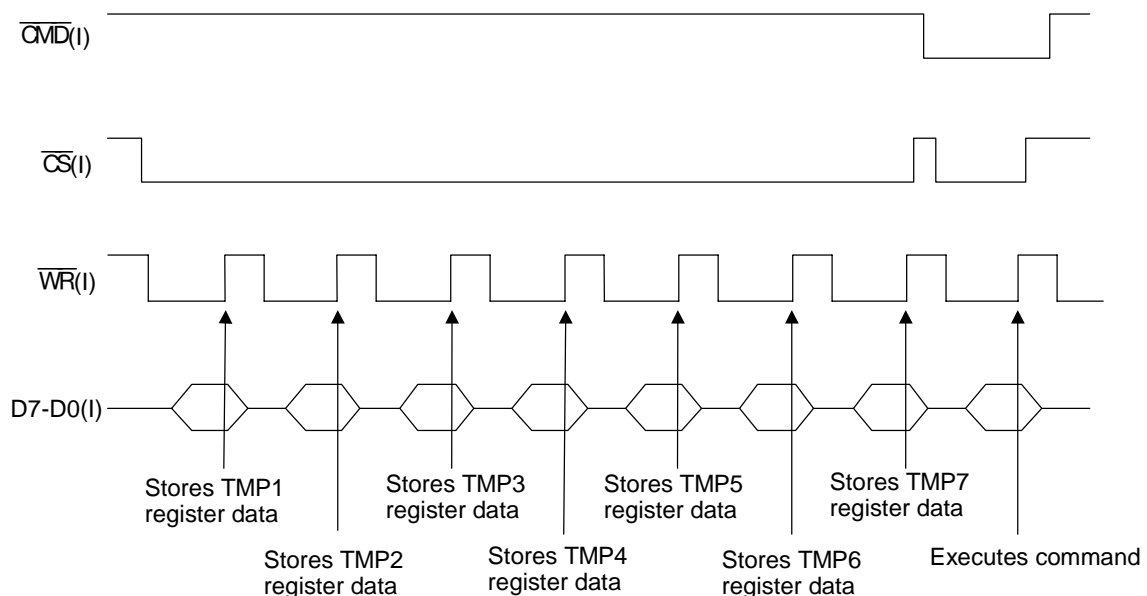

Figure 7 DADR Input Timing

As Figure 7 shows, CS and WR pulses are input 7 times when CMD is in “H” status, to input data to the TMP1 to TMP7 registers. The LSI increments the registers at the rise of the WR pulse when CMD is “H”. CMD must not be “L” while inputting data. When CMD becomes “L” while inputting data, the increment of registers is cleared.

Table 5 shows the configuration of data to be input to TMP1 to TMP7 registers.

Table 5 TMP Register Data Configuration

	D7	D6	D5	D4	D3	D2	D1	D0
TMP1 register	A23	A22	A21	A20	A19	A18	A17	A16
TMP2 register	A15	A14	A13	A12	A11	A10	A9	A8
TMP3 register	A7	A6	A5	A4	A3	A2	A1	A0
TMP4 register	T23	T22	T21	T20	T19	T18	T17	T16
TMP5 register	T15	T14	T13	T12	T11	T10	T9	T8
TMP6 register	T7	T6	T5	T4	T3	T2	T1	T0
TMP7 register	S3	S2	S1	S0	P1	P0	0	0

Input the start address of voice data to TMP1 to TMP3 registers. Input the stop address of voice data to TMP4 to TMP6 registers. Input the playback system and sampling frequency to the TMP7 register.

Table 6 shows the input data configuration of the playback system and sampling frequency.

Table 6 Data Configuration of Playback System and Sampling Frequency

S3	S2	S1	S0	
0	0	0	0	Sampling frequency 4.0 kHz
0	0	0	1	Sampling frequency 8.0 kHz
0	0	1	0	Sampling frequency 16.0 kHz
0	0	1	1	Sampling frequency 32.0 kHz
0	1	0	1	Sampling frequency 6.4 kHz
0	1	1	0	Sampling frequency 12.8 kHz
0	1	1	1	Sampling frequency 25.6 kHz
1	0	0	1	Sampling frequency 5.3 kHz
1	0	1	0	Sampling frequency 10.6 kHz
1	0	1	1	Sampling frequency 21.3 kHz

P1	P0	
0	0	Playback algorithm: 4-bit ADPCM
0	1	Playback algorithm: 4-bit ADPCM2
1	0	Playback algorithm: 8-bit non-linear PCM
1	1	Playback algorithm: 8-bit straight PCM

CVOL Command

The CVOL command adjusts the volume of the specified channel to the volume which corresponds to the size of data stored in the TMP register at the rise of the WR pulse.

Volume can be set in 16 steps up to -30 dB in -2dB step units. Set data as shown in Table 7.

Table 7 Volume Setting Data Configuration

D3	D2	D1	D0	Volume(dB)
0	0	0	0	0 dB
0	0	0	1	-2 dB
0	0	1	0	-4 dB
0	0	1	1	-6 dB
0	1	0	0	-8 dB
0	1	0	1	-10 dB
0	1	1	0	-12 dB
0	1	1	1	-14 dB
1	0	0	0	-16 dB
1	0	0	1	-18 dB
1	0	1	0	-20 dB
1	0	1	1	-22 dB
1	1	0	0	-24 dB
1	1	0	1	-26 dB
1	1	1	0	-28 dB
1	1	1	1	-30 dB

(D7-D4: Don't care)

When power is turned on and the RESET pulse is input, all channels are set to 0dB.

PAN Command

The PAN command adjusts the volume of the specified channel for the left and right respectively, to the volume which corresponds to the size of data stored in the TMP register at the rise of the WR pulse.

This command enables stereo output.

When volume is controlled by the OPT command and CVOL command, volume to be output is the volume stored in ROM multiplied by volume set by the OPT command, CVOL command, and PAN command respectively. This volume is output from LDAO and RDAO.

Volume can be set in 16 steps up to -30 dB in -2 dB step units. Set data as shown in Table 8.

Table 8 PAN Data Configuration

D7	D6	D5	D4	Volume at left side
D3	D2	D1	D0	Volume at right side
0	0	0	0	0 dB
0	0	0	1	-2 dB
0	0	1	0	-4 dB
0	0	1	1	-6 dB
0	1	0	0	-8 dB
0	1	0	1	-10 dB
0	1	1	0	-12 dB
0	1	1	1	-14 dB
1	0	0	0	-16 dB
1	0	0	1	-18 dB
1	0	1	0	-20 dB
1	0	1	1	-22 dB
1	1	0	0	-24 dB
1	1	0	1	-26 dB
1	1	1	0	-28 dB
1	1	1	1	-30 dB

FLOWCHART

Monaural Playback

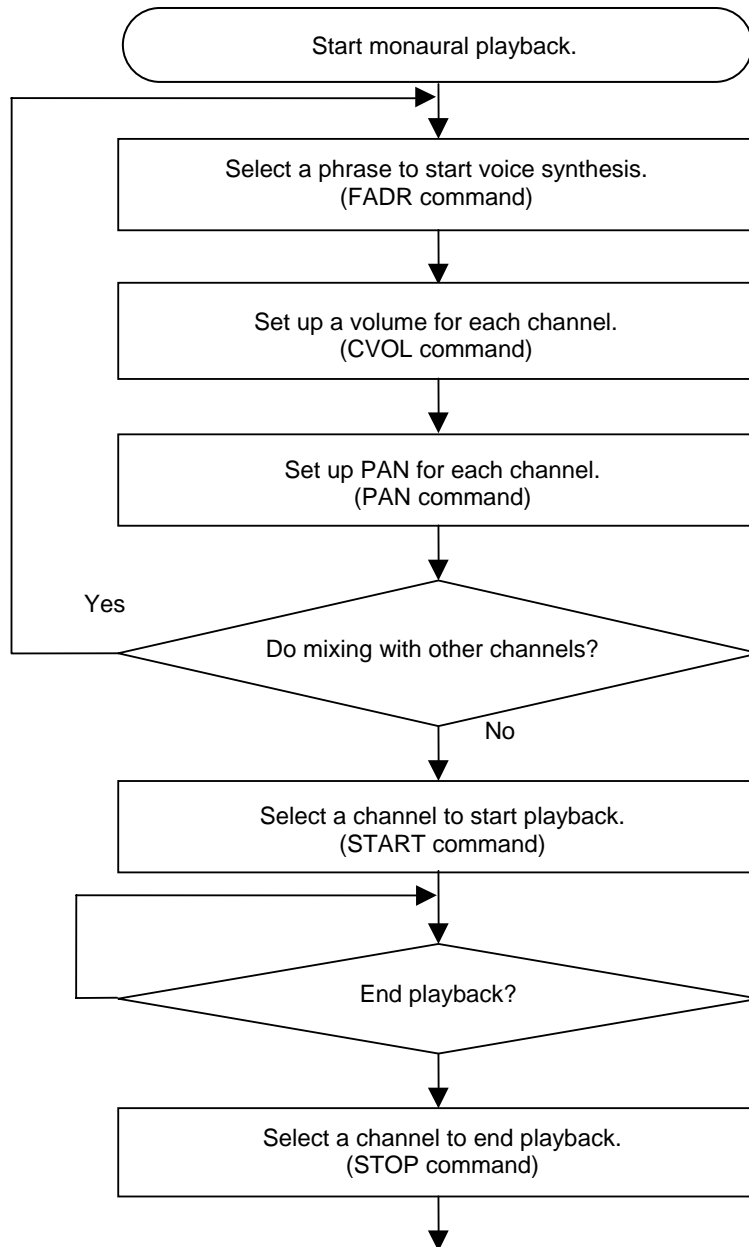

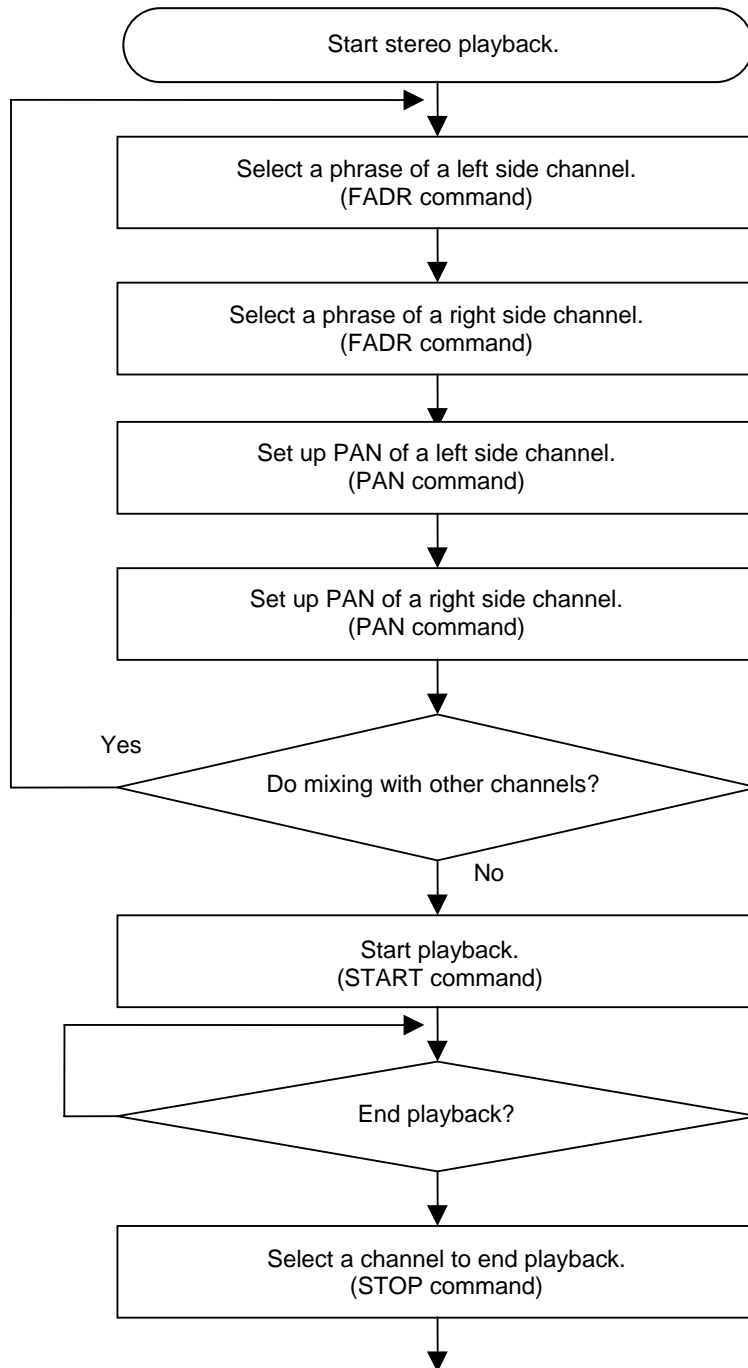
Stereo Playback

Continuous Playback

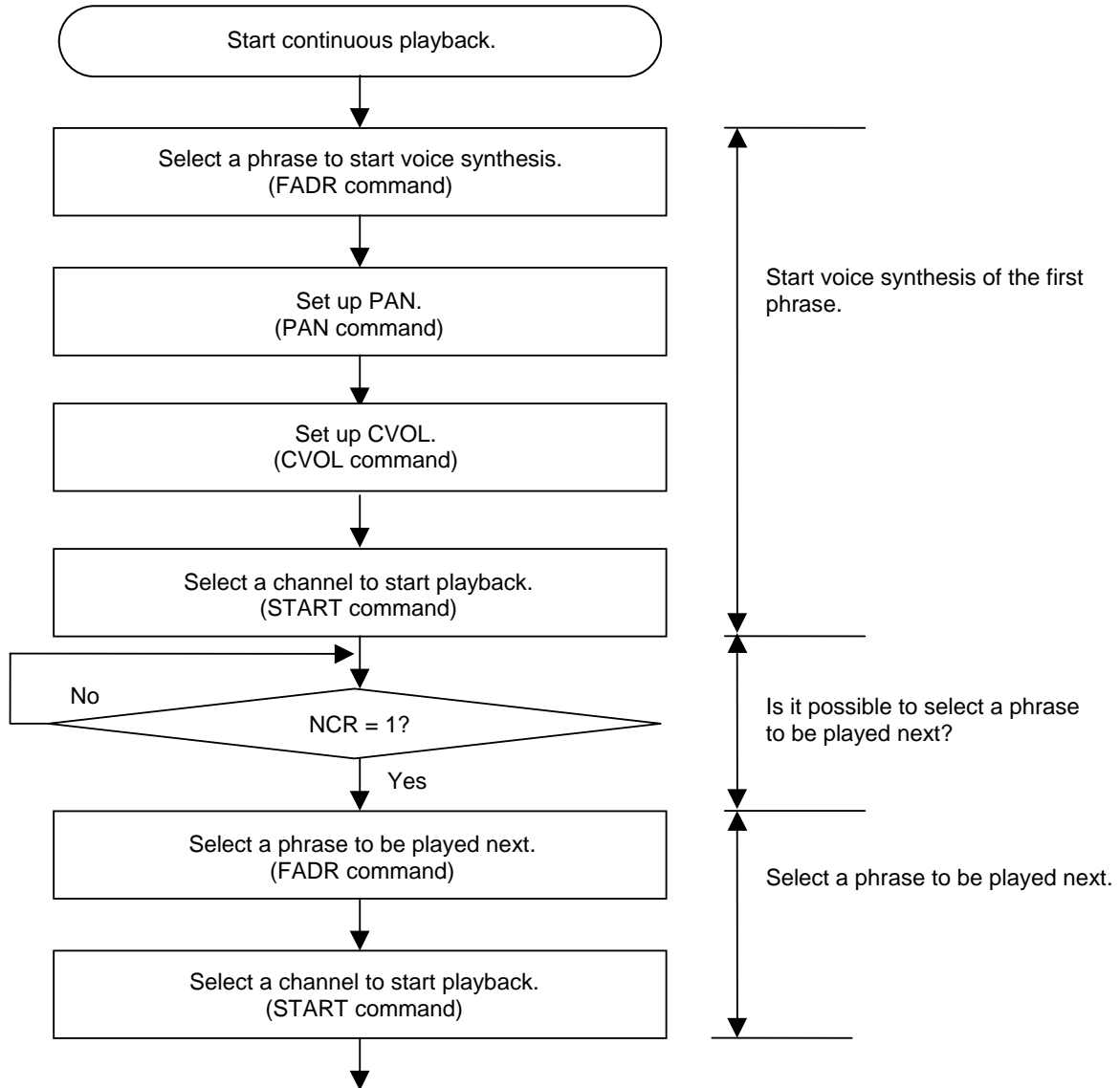

Changing Volume Level

It is possible to change the volume level of a channel that is being played. If the CVOL command is issued when voices are not being played, the changed volume level will be valid during the next playback. When the phrase control table function is used, the value of CVOL is changed by the phrase control table function because there are volume setting values in the phrase control table.

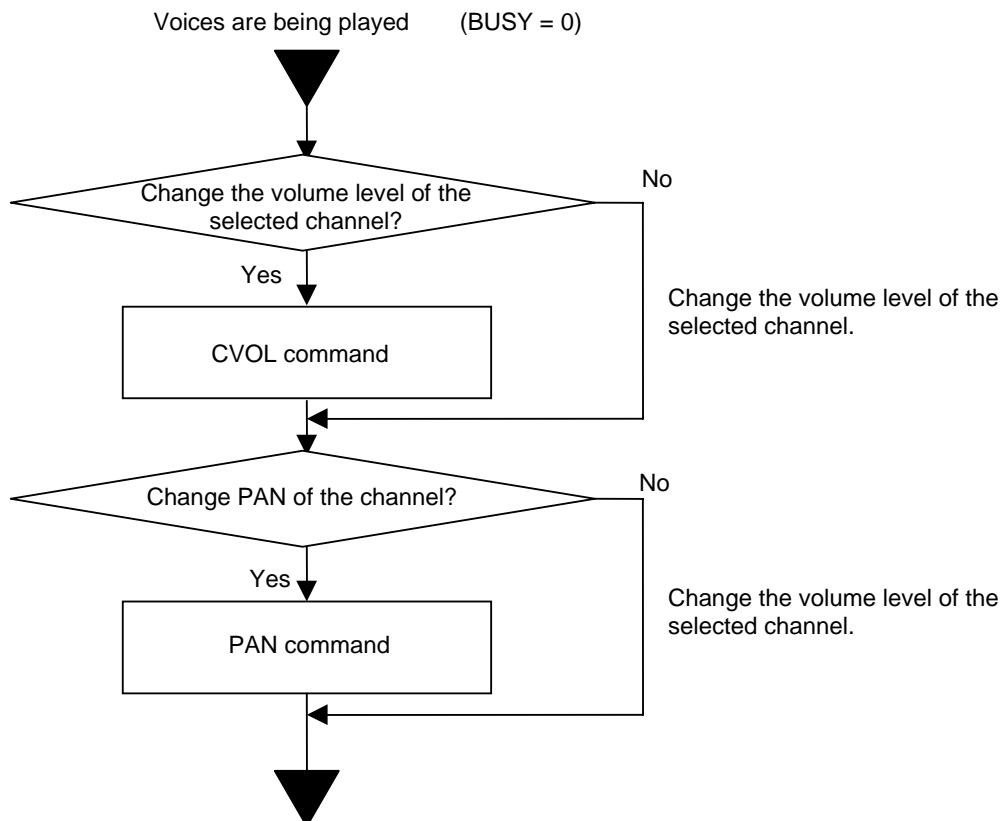

APPLICATION CIRCUITS

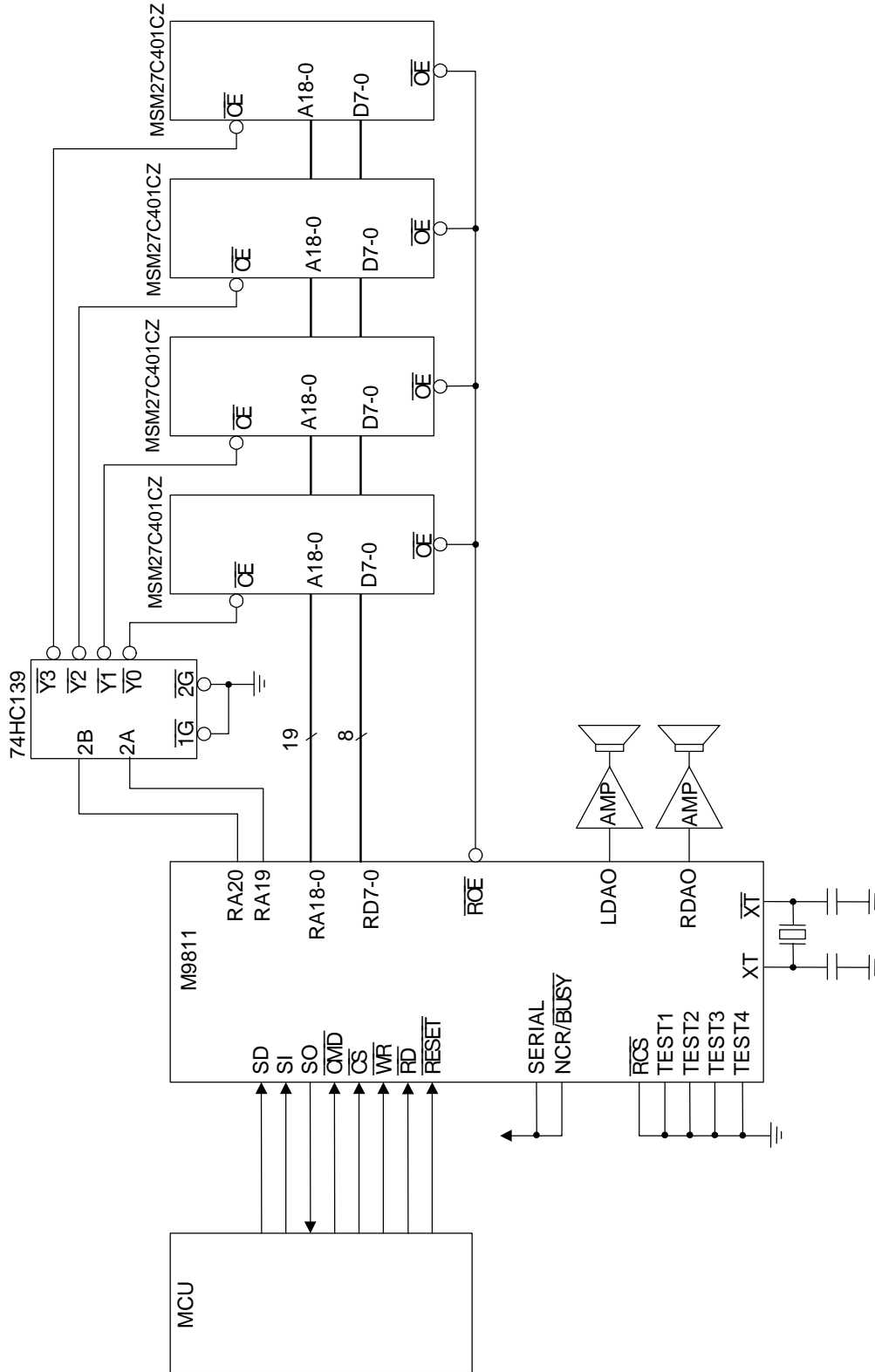

Application circuit example when four 4 Mbit OTP ROMs are connected (serial input interface)

PACKAGE DIMENSIONS

(Unit: mm)

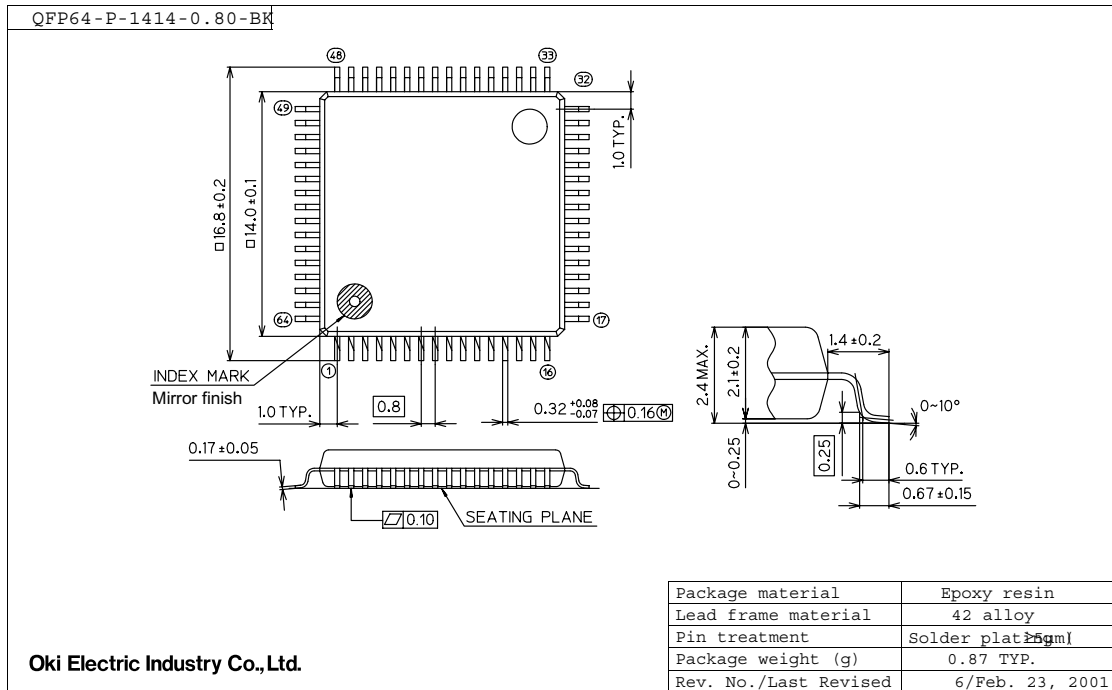

Notes for Mounting the Surface Mount Type Package

The surface mount type packages are very susceptible to heat in reflow mounting and humidity absorbed in storage.

Therefore, before you perform reflow mounting, contact Oki's responsible sales person for the product name, package name, pin number, package code and desired mounting conditions (reflow method, temperature and times).

REVISION HISTORY

Document No.	Date	Page		Description
		Previous Edition	Current Edition	
FEDL9811FULL-01	Jun. 2000	–	–	Edition 1
FEDL9811FULL-02	May. 2001	–	–	Edition 2
FEDL9811FULL-03	Jun 20, 2003	7,20,31,32	7,20,31,32	Corrected the output impedance of analog signals.
		7	7	Corrected the word "AOUT" to "LDAO,RDAO" In Analog Characteristics table.
FEDL9811FULL-04	Sep. 1, 2004	–	–	Edition 4

NOTICE

1. The information contained herein can change without notice owing to product and/or technical improvements. Before using the product, please make sure that the information being referred to is up-to-date.
2. The outline of action and examples for application circuits described herein have been chosen as an explanation for the standard action and performance of the product. When planning to use the product, please ensure that the external conditions are reflected in the actual circuit, assembly, and program designs.
3. When designing your product, please use our product below the specified maximum ratings and within the specified operating ranges including, but not limited to, operating voltage, power dissipation, and operating temperature.
4. Oki assumes no responsibility or liability whatsoever for any failure or unusual or unexpected operation resulting from misuse, neglect, improper installation, repair, alteration or accident, improper handling, or unusual physical or electrical stress including, but not limited to, exposure to parameters beyond the specified maximum ratings or operation outside the specified operating range.
5. Neither indemnity against nor license of a third party's industrial and intellectual property right, etc. is granted by us in connection with the use of the product and/or the information and drawings contained herein. No responsibility is assumed by us for any infringement of a third party's right which may result from the use thereof.
6. The products listed in this document are intended for use in general electronics equipment for commercial applications (e.g., office automation, communication equipment, measurement equipment, consumer electronics, etc.). These products are not, unless specifically authorized by Oki, authorized for use in any system or application that requires special or enhanced quality and reliability characteristics nor in any system or application where the failure of such system or application may result in the loss or damage of property, or death or injury to humans.
Such applications include, but are not limited to, traffic and automotive equipment, safety devices, aerospace equipment, nuclear power control, medical equipment, and life-support systems.
7. Certain products in this document may need government approval before they can be exported to particular countries. The purchaser assumes the responsibility of determining the legality of export of these products and will take appropriate and necessary steps at their own expense for these.
8. No part of the contents contained herein may be reprinted or reproduced without our prior permission.

Copyright 2004 Oki Electric Industry Co., Ltd.