



VOLTAGE RANGE: 50 --- 600V

CURRENT: 8.0A

Features

- Low cost
- Diffused junction
- Glass passivated junction
- Low forward voltage drop
- High current capability
- Easily cleaned with Alcohol, Isopropanol and similar solvents
- The plastic material carries U/L recognition 94V-0

ITO - 220AC

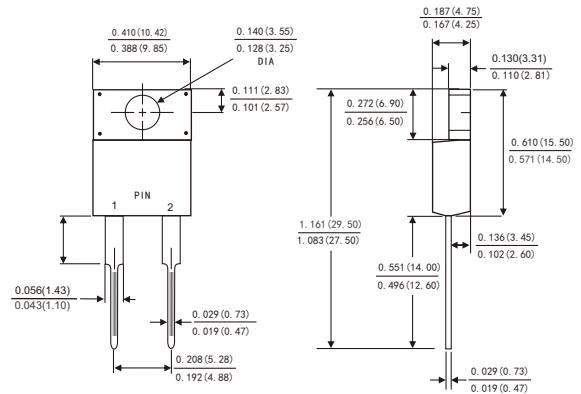

Mechanical Data

- Case: JEDEC TO-220AC
- Terminals: solderable per MIL-STD-202, Method 208
- Polarity: Color band denotes cathode
- Weight: 0.064 ounces, 1.81 gram
- Mounting position: Any

MAXIMUM RATINGS AND ELECTRICAL CHARACTERISTICS

Ratings at 25 °C ambient temperature unless otherwise specified.

Single phase, half wave, 60 Hz, resistive or inductive load. For capacitive load, derate by 20%.

		MUR 805F	MUR 810F	MUR 815F	MUR 820F	MUR 830F	MUR 840F	MUR 860F	UNITS
Device marking code		U805F	U810F	U815F	U820F	U830F	U840F	U860F	
Maximum recurrent peak reverse voltage	V_{RRM}	50	100	150	200	300	400	600	V
Maximum RMS voltage	V_{RMS}	35	70	105	140	210	280	420	V
Maximum DC blocking voltage	V_{DC}	50	100	150	200	300	400	600	V
Maximum average forward rectified current total device (rated V_R), $T_C=150$	$I_{(AV)}$	8.0							A
Peak forward surge current 8.3ms single half-sine-wave superimposed on rated load	I_{FSM}	100							A
Maximum instantaneous forward voltage (Note1) @ $I_F=8.0A, T_C=25$ / @ $I_F=8.0A, T_C=150$	V_F		0.975 / 0.895			1.30 / 1.00	1.50 / 1.20		V
Maximum reverse current at rated DC blocking voltage @ $T_j=25$ / $T_j=150$	I_R		5.0 / 250			10 / 500			μA
Maximum reverse recovery time (Note2) / (Note3)	t_{rr}		25 / 35			50 / 60			ns
Typical thermal resistance junction to case	$R_{\theta JC}$		3.0			2.0			/W
Operating junction temperature range	T_j	- 65 ---- + 175							
Storage temperature range	T_{STG}	- 65 ---- + 175							

NOTE: 1. Pulse test: pulse width=300 μs , duty cycle 2.0%

2. Measured with $I_F=0.5A, I_R=1A, I_{rr}=0.25A$.

3. Measured with $I_F=1.0A, di/dt=50A/\mu s$.

Ratings AND Characteristic Curves

FIG.1 –TYPICAL FORWARD CHARACTERISTIC

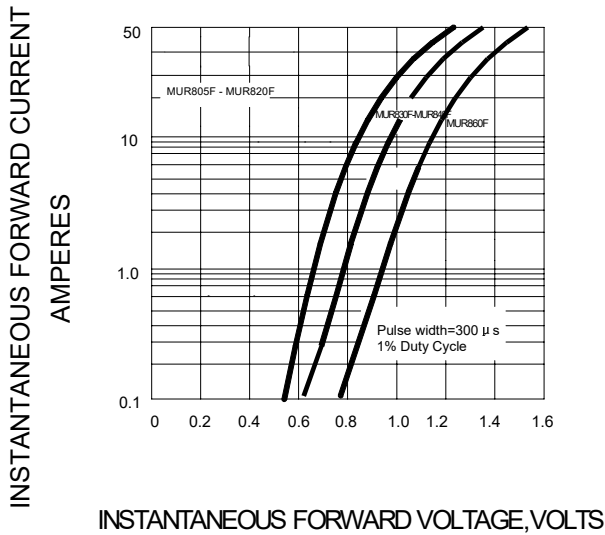

FIG.2 –TYPICAL REVERSE CHARACTERISTICS

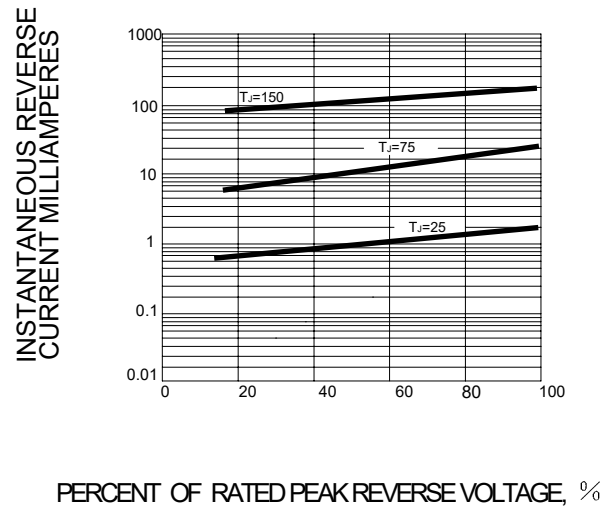

FIG.3 – PEAK FORWARD SURGE CURRENT

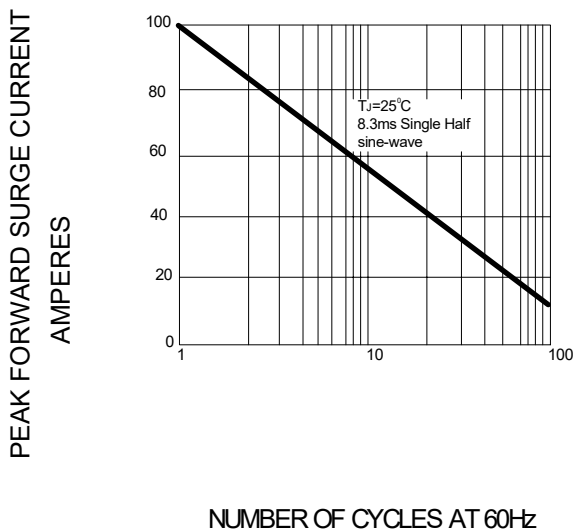

FIG.4 – FORWARD DERATING CURVE

