



Obsolescence Notice

This product is obsolete.

This information is available for your convenience only.

For more information on Zarlink's obsolete products and replacement product lists, please visit http://products.zarlink.com/obsolete_products/

MV8870 / MV8870-1

INTEGRATED DTMF RECEIVER

The MV8870 / MV8870-1 is a complete DTMF receiver integrating both the bandsplit filter and digital decoder functions, fabricated in GPS's double-poly ISO2-CMOS technology. The filter section uses switched capacitor techniques for high and low group filters; the decoder uses digital counting techniques to detect and decode all 16 DTMF tone pairs into a 4-bit code.

External component count is minimised by on-chip provision of a differential input amplifier, clock oscillator and latched 3-state bus interface.

The MV8870 and MV8870-1 are functionally identical, but differ in Electrical Characteristics.

FEATURES

- Complete DTMF Receiver
- Low Power Consumption
- Internal Gain Setting Amplifier
- Adjustable Guard Time
- Central Office Quality

APPLICATIONS

- Receiver Systems for BT or CEPT Specifications
- Paging Systems
- Repeater Systems / Mobile Radio
- Credit Card Systems
- Remote Control

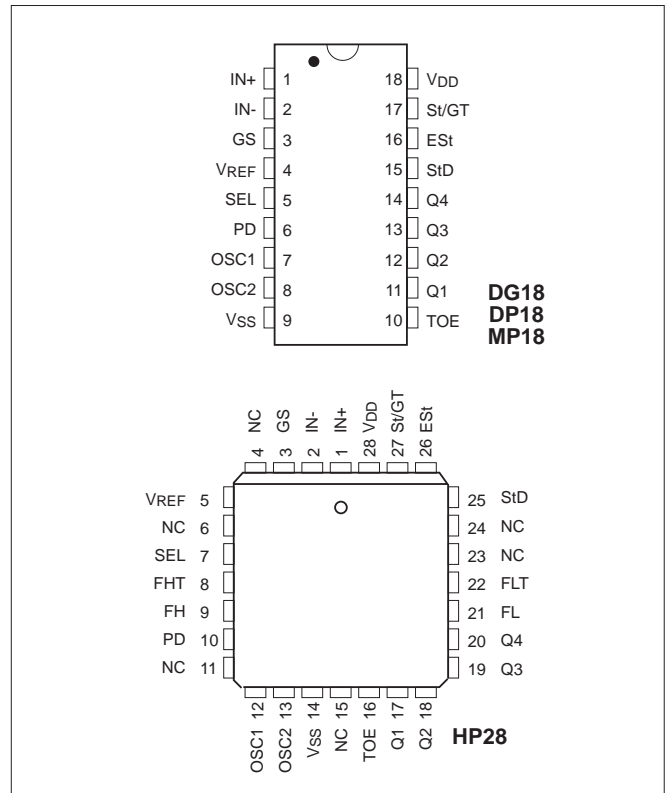

Figure 1: Pin connections - top view

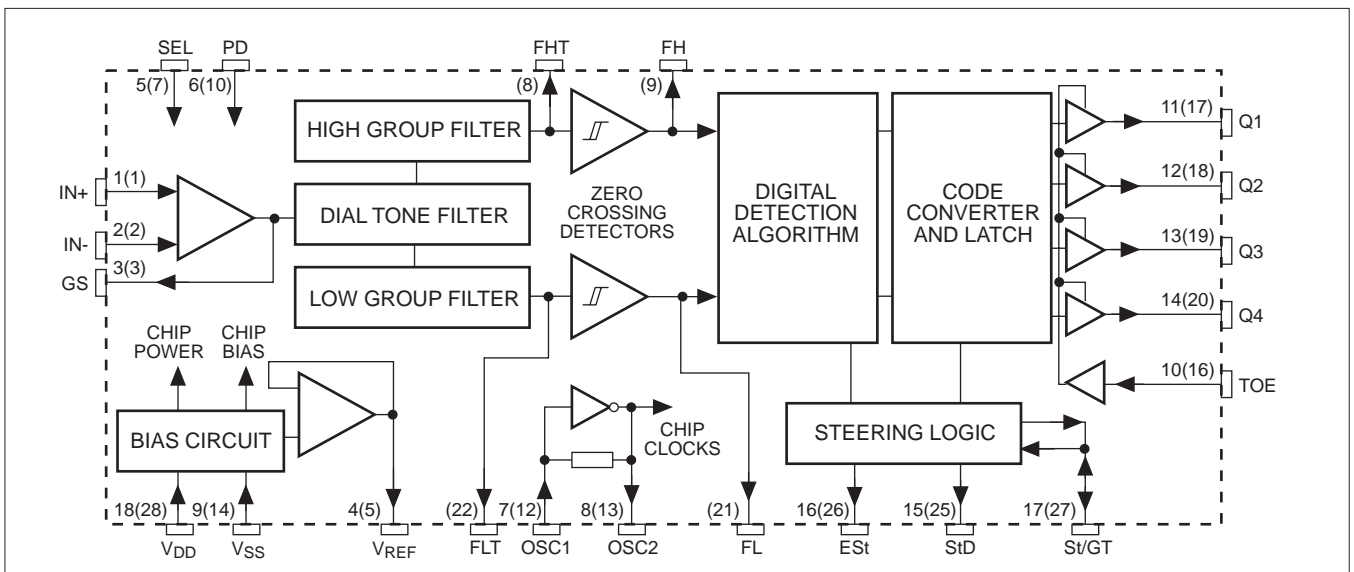

Figure 2: Functional block diagram (Pin numbers in brackets refer to HP package)

MV8870/MV8870-1

FUNCTIONAL DESCRIPTION

The MV8870 / MV8870-1 monolithic DTMF receiver offers small size, low power consumption and high performance. Its architecture consists of a bandsplit filter section, which separates the high and low tone groups, followed by a digital counting section which verifies the frequency and duration of the received tones before passing the corresponding code to the output bus.

FILTER SECTION

Separation of the low-group and high-group tones is achieved by applying the DTMF signal to the inputs of two sixth-order switched capacitor band-pass filters, the bandwidths of which correspond to the low and high group frequencies. The filter section also incorporates notches at 350 and 440 Hz for exceptional dial tone rejection (see Fig.3). Each filter is followed by a single order switched capacitor filter section which smooths the signals prior to limiting. Limiting is performed by high-gain comparators which are provided with hysteresis to prevent detection of unwanted low-level signals. The outputs of the comparators provide full rail logic swings at the frequencies of the incoming DTMF signals.

For testing and monitoring, the high and low group filter and zero crossing detector outputs are made available via FHT, FH, FLT and FL (HP package only).

DECODER SECTION

Following the filter section is a decoder employing digital counting techniques to determine the frequencies of the incoming tones and to verify that they correspond to standard DTMF frequencies. A complex averaging algorithm protects against tone simulation by extraneous signals such as voice while providing tolerance to small frequency deviations and variations. This averaging algorithm has been developed to ensure an optimum combination of immunity to talk-off and tolerance to the presence of interfering frequencies (third tones) and noise. When the detector recognises the simultaneous presence of two valid tones (this is referred to as the 'Signal Condition' in some industry specifications) the Early Steering output (ESt) will go to an active state. Any subsequent loss of signal condition will cause the ESt pin to go to its inactive state (see Fig.5).

STEERING CIRCUIT

Before registration of a decoded tone-pair, the receiver checks for a valid signal duration (referred to as (character recognition condition)). This check is performed by an external RC time constant driven by ESt. A logic high on ESt causes the voltage at the SVGT pin (V_{SVGT}) to rise as the capacitor discharges (see Figs.4 and 5).

Provided signal condition is maintained (ESt remains high) for the validation period (t_{GTP}), V_{SVGT} reaches the threshold (V_{TS}) of the steering logic which allows it to register the tone pair and strobe the corresponding 4-bit code into the output latch (see Fig.6). At this point the SVGT pin is activated as an output and drives V_{SVGT} to V_{DD} (see Fig.5).

St/GT continues to drive high as long as ESt remains high. After a short delay (t_{DP}) to allow the output latch to settle, the delayed steering output pin (StD) goes high to indicate that the code for a new received tone-pair is available. The contents of the output latch are output onto the output bus (Q1 to Q4 pins) when the three-state output enable (TOE) pin is high.

The steering circuit works in reverse to validate the interdigit pause between signals. Thus as well as rejecting signals too short to be considered valid, the receiver will tolerate signal interruptions (drop-out) too short to be considered a valid pause. This facility, together with the capability of selecting the steering time constants externally, allows the designer to tailor performance to meet a wide variety of system requirements.

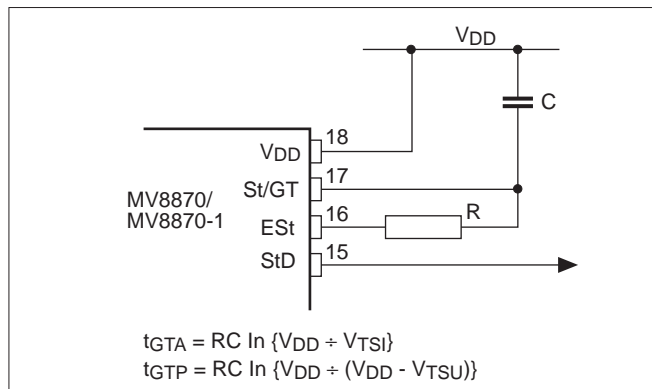

Figure 4: Basic Steering Circuit

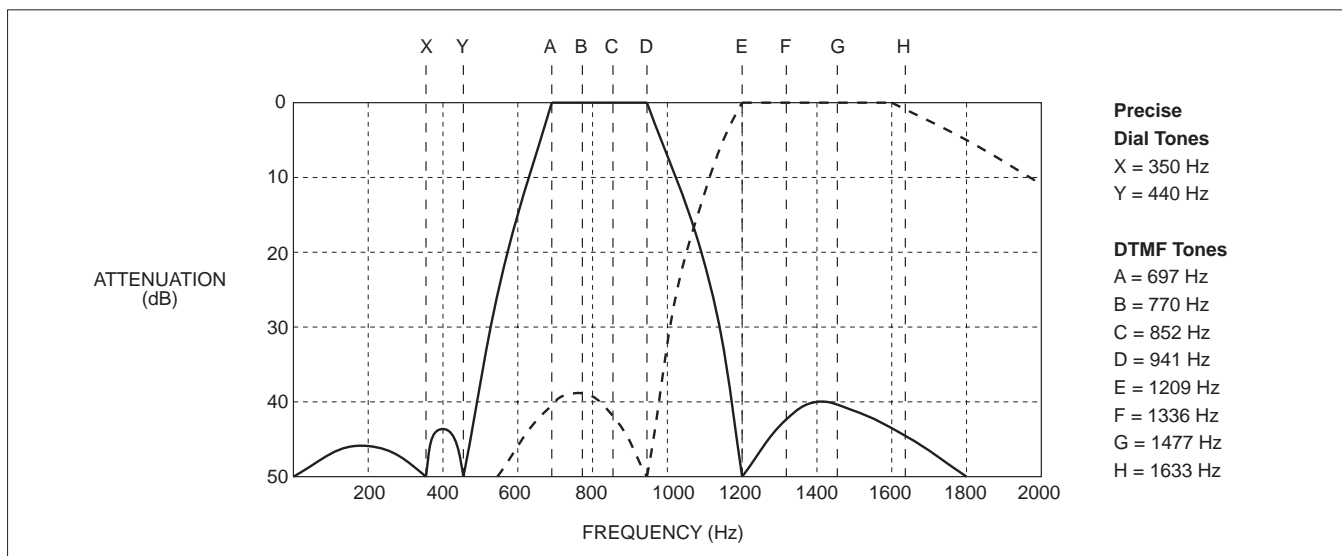

Figure 3: Filter response

APPLICATIONS

A simple application circuit is shown in Fig.7. This has a symmetric guard time circuit, a single-ended analog input and a dedicated crystal oscillator.

GUARD TIME ADJUSTMENT

In many situations not requiring separate selection of tone duration and interdigit pause, the simple steering circuit shown in Fig.7 is applicable. Component values are chosen according to the formulae (see Figs. 4, 8a and 8b):-

$$t_{REC} = t_{DP} + t_{GTP}$$

$$t_{ID} = t_{DA} + t_{GTA}$$

The value of t_{DP} is a device parameter (see Dynamic Characteristics and Fig.5) and t_{REC} is the minimum signal duration to be recognised by the receiver. Likewise t_{DA} is a

device parameter (Fig.5) and t_{ID} is the minimum time taken to recognise an interdigit pause. A value for C2 of 0.1 μ -F is recommended for most applications, leaving R3 to be selected by the designer.

Different steering arrangements may be used to select independently the guard times for tone present (t_{GTP}) and tone absent (t_{GTA}). This may be necessary to meet system specifications which place both accept and reject limits on both tone duration and interdigit pause. Guard Time adjustment also allows the designer to tailor system parameters such as talk-off and noise immunity. Increasing t_{REC} improves talk-off performance since it reduces the probability that tones simulated by speech will maintain signal conditions long enough to be registered. Alternatively a relatively short t_{REC} with a long t_{ID} would be appropriate for extremely noisy environments where fast acquisition time and immunity to tone drop-outs are required. Design information for guard time adjustment is shown in Figs. 8a and 8b.

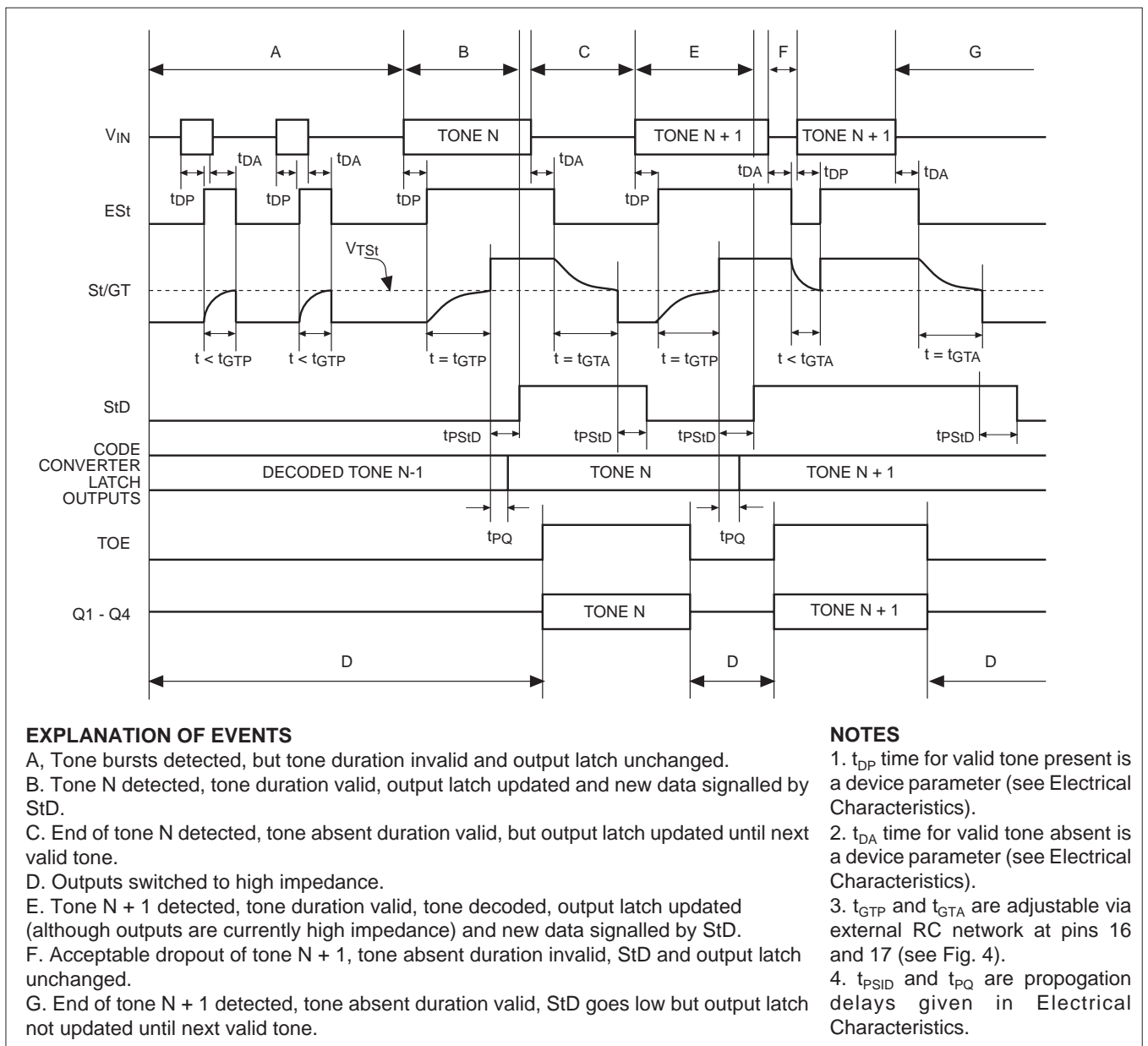

Figure 5: Timing diagram

MV8870/MV8870-1

f _{LOW}	f _{HIGH}	DIGIT	TOE	SELECT = L				SELECT = H			
				Q4	Q3	Q2	Q1	Q4	Q3	Q2	Q1
697	1209	1	H	0	0	0	1	0	0	0	1
697	1336	2	H	0	0	1	0	0	0	1	0
697	1477	3	H	0	0	1	1	0	0	1	1
770	1209	4	H	0	1	0	0	0	1	0	0
770	1336	5	H	0	1	0	1	0	1	0	1
770	1477	6	H	0	1	1	0	0	1	1	0
852	1209	7	H	0	1	1	1	0	1	1	1
852	1336	8	H	1	0	0	0	1	0	0	0
852	1477	9	H	1	0	0	1	1	0	0	1
941	1209	0	H	1	0	1	0	0	0	0	0
941	1336	*	H	1	0	1	1	1	0	1	0
941	1477	#	H	i	1	0	0	1	0	1	1
697	1633	A	H	1	1	0	1	1	1	0	0
770	1633	B	H	1	1	1	0	1	1	0	1
852	1633	C	H	1	1	1	1	1	1	1	0
941	1633	D	H	0	0	0	0	1	1	1	1
-	-	Any	L	Z	Z	Z	Z	Z	Z	Z	Z

Figure 6: Functional decode table

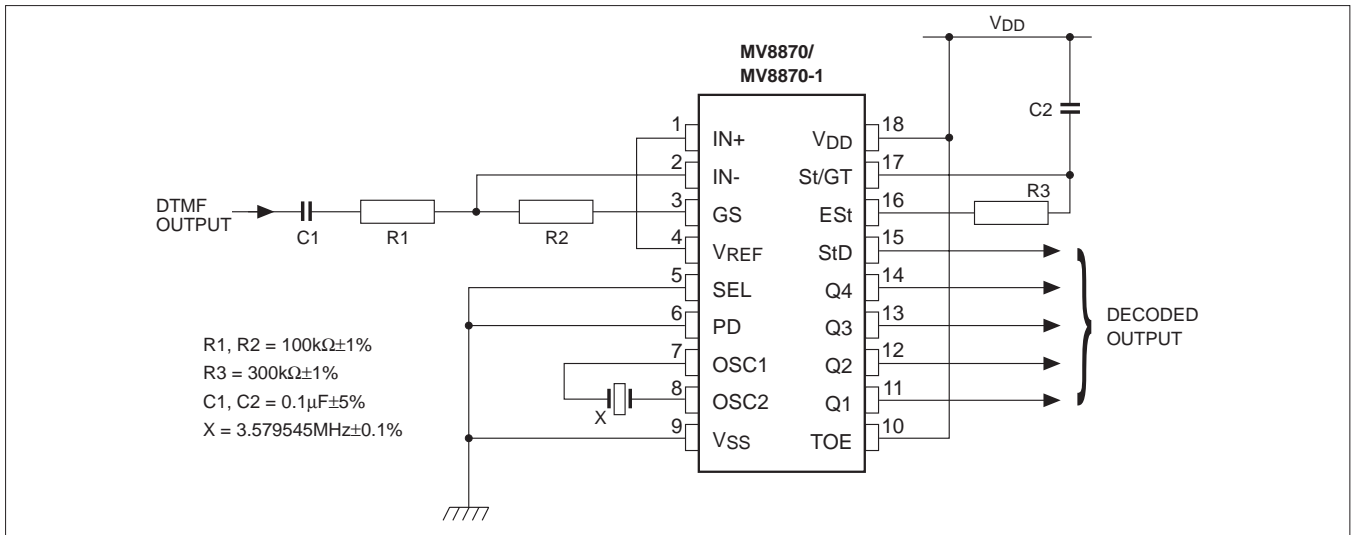

Figure 7: Simple application circuit; single ended input

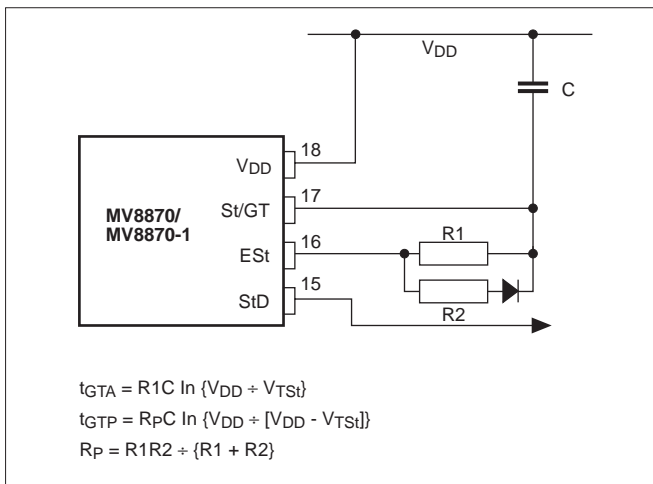

Figure 8a: Guard time adjustment ($t_{GTP} < t_{GTA}$)

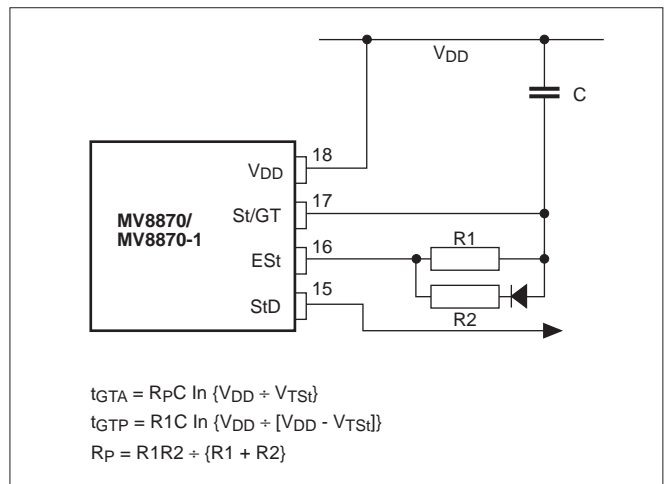

Figure 8b: Guard time adjustment ($t_{GTP} > t_{GTA}$)

DIFFERENTIAL INPUT CONFIGURATION

The input arrangement of the MV8870 / MV8870-1 provides a differential input op. amp. and a bias source (V_{REF}) to bias the inputs at mid-rail. The gain may be adjusted through a feedback resistor from the op. amp. output (GS). In a single-ended configuration the input pins are connected as shown in Fig. 7 where the op. amp. is connected to give unity gain and the V_{REF} pin biases the input at $(V_{DD} \div 2)$.

Fig.9 shows the differential configuration. In this circuit gain is adjusted through the feedback resistor R5.

CRYSTAL OSCILLATOR

The internal clock circuit is completed with the addition of an external 3.58MHz crystal which is normally connected as shown in Fig. 7. However it is possible to configure several MV8870 / MV8870-1 devices to use only a single oscillator crystal.

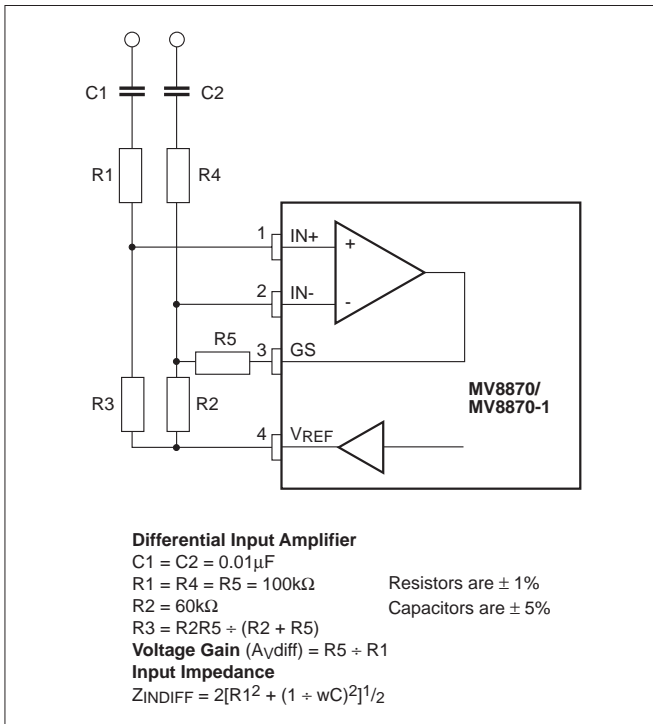

Figure 9: Differential input configuration

The devices are chained together with the oscillator output of the first device in the chain capacitively coupled to the oscillator input of the second device and so on down the chain. The details are shown in Fig. 10. Precision balancing capacitors are not required as problems of unbalanced loading are not a concern.

RECEIVER SYSTEM FOR BT SPECIFICATION POR 1151

The circuit shown in Fig.11 illustrates the use of the MV8870-1 in a typical receiver system. The BT specification defines the non-operate level as input signals below 34 dBm. This is obtained by choosing R1 and R2 to give 3dB of attenuation so that an input of 34 dBm corresponds to -37 dBm at the op. amp. output pin (GS). The tolerances on R3 and C2 give a tolerance on guard time of 6%. For better performance the non-symmetric guard time circuit shown in Fig.12 is recommended.

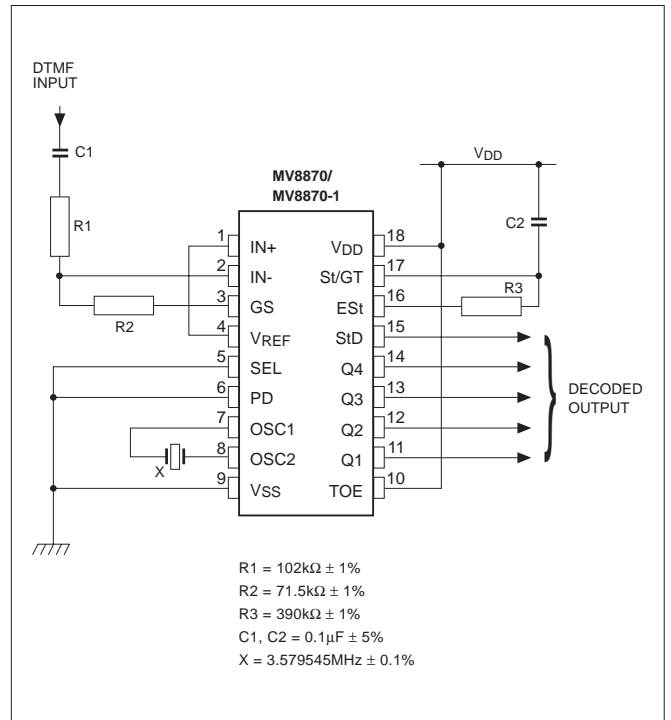

Figure 11: Single ended circuit for BT/CEPT Specs

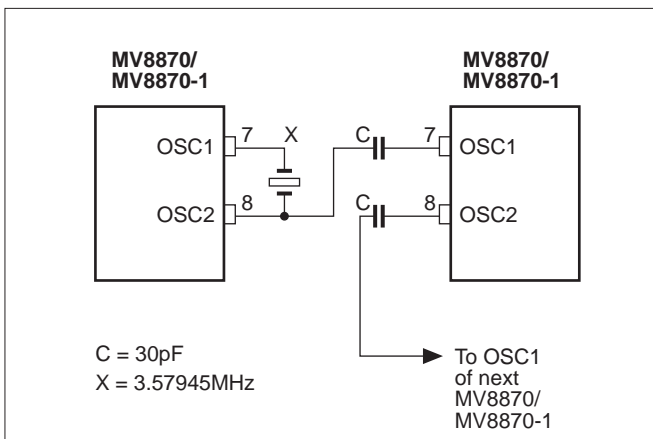

Figure 10: Oscillator circuit

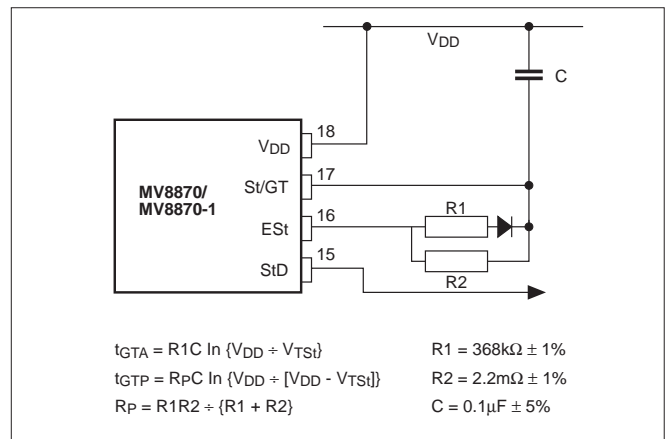

Figure 12: Non-symmetric guard time circuit

MV8870/MV8870-1

PIN DESCRIPTIONS (Note 1)

Symbol	Pin no	Pin name and description
IN+, IN -	1 (1) 2 (2)	In Plus and Minus (Voltage Inputs). These are respectively the non-inverting and inverting inputs to the front-end op-amp. The DTMF input is applied to these pins in normal operation.
GS	3 (3)	Gain Select (Voltage Output). This pin is connected to the output of the front-end op-amp. A feedback resistor between this pin and the inverting input (IN -) controls the front-end gain.
VREF	4 (5)	Reference Voltage (Voltage Output). This pin outputs a voltage which is half-way between the power supply voltages (V_{SS} and V_{DD}). It can be used to bias the input signal.
SEL	5 (7)	Select Input. This pin determines the Q4.....Q1 truth table as shown in Fig. 6
PD	6 (10)	Power Down Input. This pin is used to power down and inhibit the oscillator. It is active high and includes an internal pull-up resistor.
FHT	- (8)	Filter High Tones. Sine wave output from the high group filter circuit.
FH	- (9)	High Frequency Output. Square wave output from the high group zero crossing detector.
OSC1	7 (12)	Oscillator 1 (Digital Input). This is the input to the inverter of the oscillator circuit. There is an internal biasing resistor between this pin and the inverter output (OSC2). A 3.579545MHz crystal is normally connected externally between the two pins to complete the oscillator circuit.
OSC2	8 (13)	Oscillator 2 (Digital Output). This is the output of the inverter of the oscillator circuit. There is an internal biasing resistor between this pin and the inverter input (OSC1). A 3.579545MHz crystal is normally connected externally between the two pins to complete the oscillator circuit.
V_{SS}	9 (14)	Negative Supply (Power Input). This is the negative power supply for the device. It is normally 0V.
TOE	10 (16)	Three-State Output Enable (Digital Input with Pull-up). If this pin is high then the decoder outputs (Q1 to Q4) are enabled. If it is low then the outputs go into their high-impedance state. There is an internal pull-up at this pin.
Q1 Q2 Q3 Q4	11 (17) 12 (18) 13 (19) 14 (20)	Q1 to Q4 (Three-State Outputs). When the TOE pin is high these pins output the code in the output latch which corresponds to the last valid tone-pair detected. They go into their high impedance state when the TOE pin is low.
FL	- (21)	Low Frequency Output. Square wave output from the low group zero crossing detector
FLT	- (22)	Filter Low Tones. Sine wave output from the low group filter circuit.
StD	15 (25)	Delayed Steering (Digital Output). This pin follows the ESt and SVGT pins. It goes high to indicate that a new tone-pair has been detected and the corresponding code has been loaded into the output latch. It goes low to indicate that a new tone-pair is expected.
ESt	16 (26)	Early Steering (Digital Output). This pin goes high when the digital detection algorithm decides that there is a valid DTMF input. It goes low as soon as the algorithm decides that there is no valid DTMF input. In normal use this pin is used to drive an external guard time circuit which in turn drives the SUGT pin.
SVGT	17 (27)	Steering / Guard Time (Voltage Input / Digital Output). This pin follows the ESt pin. When ESt pin changes state this pin acts as an input and monitors the voltage developed here by the ESt pin acting through the external guard time circuit. When the voltage reaches the internally generated VTSI level then this pin acts as an output and pulls itself fully to the state of the ESt pin. When this pin goes fully high a new code is loaded into the output latch and the StD pin goes high. When this pin goes fully low the device prepares itself for a new tone-pair and the StD pin goes low.
V_{DD}	18 (28)	Positive Supply (Power Input). This is the positive power supply for the device. It is normally 5V.

Note: 1. Figures in brackets are for HP28 package.

RECOMMENDED OPERATING RANGE

Characteristic	Value (MV8870)			Value (MV8870-1)			Units	Conditions	
	Symbol	Min	Typ	Max	Min	Typ			Max
Positive supply voltage	V_{DD}	4.75	5.0	5.25	4.75	5.0	5.25	V	
Operating temperature	T_{OP}	-40	+25	+80	-40	+25	+80	$^{\circ}\text{C}$	

ELECTRICAL CHARACTERISTICS Over Recommended Operating Range (unless otherwise specified)

These characteristics are guaranteed over the following conditions (unless otherwise stated):

Voltages measured with respect to ground (V_{SS}).

Typical figures are for design aid only; they are not guaranteed and are not subject to production testing.

STATIC CHARACTERISTICS

Characteristic	Symbol	Value (MV8870)			Value (MV8870-1)			Units	Conditions
		Min	Typ	Max	Min	Typ	Max		
Power dissipation	P_D		15	35		15	37	mW	$f_0 = 3.579545\text{MHz}$
V_{DD} supply current	I_{DD}		3.0	7.0		3.0	7.0	mA	
Input high voltage (OSC1 & TOE)	V_{IH}	3.5		V_{DD}	3.5		V_{DD}	V	
Input low voltage (OSC1 and TOE)	V_{IL}	0		1.5	0		1.5	V	
Input leakage current (OSC1, IN + and IN-)	I_I		100			100		mA	$0 \leq V_{PIN} \leq V_{DD}$
Internal pull-up current (TOE)	I_{PU}		7.5	15.0		7.5	15.0	μA	$0 \leq V_{PIN} \leq V_{DD}$
Steering threshold voltage (St/GT)	V_{Tst}	2.2	2.35	2.5	2.2	2.35	2.5	V	
Low level output voltage	V_{OL}		0.03			0.03		V	No Load
High level output voltage	V_{OH}		4.97			4.97		V	No Load
Output low sink current (OSC2, Q1-Q4, StD and ESt)	I_{OL}	1.0	2.5		1.0	2.5		mA	$V_{PIN} = 0.4\text{V}$
Output high source current (OSC2, Q1-Q4, StD and ESt)	I_{OH}	0.4	0.8		0.4	0.8		mA	$V_{PIN} = 4.6\text{V}$
Reference voltage	V_{REF}	2.4		2.7	2.4		2.8	V	No Load
V_{REF} output resistance	R_{REF}		10.0		10.0			$\text{k}\Omega$	
Pin capacitance	C_P		7.0	15.0		7.0	15.0	pF	Pin to supplies

MV8870/MV8870-1

DYNAMIC CHARACTERISTICS: INPUT OP AMP

Characteristic	Symbol	Value (MV8870)			Value (MV8870-1)			Units	Conditions
		Min	Typ	Max	Min	Typ	Max		
Input impedance (IN+ and IN-)	R_{IN}		10			10		M Ω	1 kHz
Input offset voltage (IN+ and IN-)	V_{OS}		25			25		mV	
Input leakage current	I_{IN}		100			100		nA	$V_{SS} < V_{IN} < V_{DD}$
Power supply rejection	PSRR		60			60		dB	1 kHz
Common mode range	V_{CM}		3.0			3.0		V	No Load
Common mode rejection	CMRP		60			60		dB	$V_{IN} = V_{REF} + 1.3V$
DC open loop voltage gain	A_{VOL}		65			65		dB	
Open loop unity gain bandwidth	f_C		1.5			1.5		MHz	
Output voltage swing (GS)	V_O		4.5			4.5		Vp-p	R_{OUT} to $V_{SS} \geq 100k\Omega$
Output capacitive load (GS)	C_{OUT}			100			100	pF	
Output resistive load (GS)	R_{OUT}	50			50			k Ω	

DYNAMIC CHARACTERISTICS: OSCILLATOR CIRCUIT

Characteristic	Symbol	Value (MV8870 and MV8870-1)			Units	Conditions
		Min	Typ	Max		
Crystal/clock frequency (OSC1 and OSC2)	f_O	3.579	3.579545	3.5831	MHz	
Oscillator input rise time (OSC1) - external clock	t_{OR}			110	ns	See Fig.13
Oscillator input high time (OSC1) - external clock	t_{OH}	110		170	ns	See Fig.13
Oscillator input fall time (OSC1) - external clock	t_{OF}			110	ns	See Fig.13
Oscillator Input Low Time (OSC1 Pin) - external clock	t_{OL}	110		170	ns	See Fig.13
Oscillator Output Load (OSC2)	C_{LO}			30	pF	

DYNAMIC CHARACTERISTICS: DETECTOR

Characteristic	Symbol	Value (MV8870)			Value (MV8870-1)			Units	Notes
		Min	Typ	Max	Min	Typ	Max		
Valid input level (GS)	V _{VL} P _{VL}	77.7 -29		2458 1.0	6-17 -31		2458 10	mV _{p-p} dBm	1, 2, 3, 5, 6, 9
Invalid input level (GS)	V _{IL} P _{IL}						30.8 -37	mV _{p-p} dBm	1, 2, 3, 5, 6, 9
Acceptable positive twist	T _{AP}		10		6.0	10		dB	2, 3, 6, 9
Acceptable negative twist	T _{AN}		10		6.0	10	—	dB	2, 3, 6, 9
Frequency deviation accept	Δ _{FA}	-1.5 -2.0		+1.5 +2.0	-1.5 -2.0		+1.5 +2.0	% Hz	2, 3, 5, 9
Frequency deviation rejected as too low	Δ _{FRL}		-5.0	-3.5		-5.0	-3.5	%	2, 3, 5, 9
Frequency deviation rejected as too high	Δ _{FRH}	3.5	5.0	.	3.5	5.0	—		2, 3, 5, 9
Third tone tolerance	P _{ITT}	-16				-18		dB	2, 3, 4, 5, 9, 12
Noise tolerance	P _{NT}		-12			-12		dB	2, 3, 4, 5, 7, 9, 10
Dial tone tolerance	P _{DTT}		+22			+22		dB	2, 3, 4, 5, 8, 9, 11
Tone present detect time	t _{DP}	5	11	14	5	11	14	ms	
Tone absent detect time	t _{DA}	0.5	4.0	8.5	0.5	4.0	8.5	ms	

NOTES

1. dBm = decibels above or below a reference power of 1 mW into a 600Ω load.
2. Digit sequence consists of all DTMF tones.
3. Tone duration = 40ms, tone pause = 40ms.
4. Signal condition consists of nominal DTMF frequencies.
5. Both tones in composite signal have equal amplitudes.
6. Tone pair is deviated by ± (1.5% + 2Hz).
7. Bandwidth limited (3kHz) Gaussian noise.
8. The precise dial tone frequencies are (350Hz and 440Hz) ± 2%.
9. For an error rate of better than 1 in 10,000.
10. Referenced to lowest frequency component in DTMF signal.
11. Referenced to the minimum valid input level.
12. Refer to Fig.11. Input DTMF Tone Level at -25dBm (-28dBm at GS pin). Interference Frequency Range is 480 to 3400Hz.

DYNAMIC CHARACTERISTICS: DECODER

Characteristic	Symbol	Value (MV8870/MV8870-1)			Units	Conditions
		Min	Typ	Max		
Propagation delay (SVGT to Q)	t _{PQ}		8	11	μs	TOE high. See Fig.14
Propagation delay (SVGT to StD)	t _{PSID}		12		μs	See Fig. 14
Output data set-up time (Q to StD)	t _{QSID}		3.4		μs	TOE high. See Fig.14
Enable propagation delay (TOE to Q)	t _{PTE}		50	60	ns	R _L = 10kΩ(pulldown) C _L = 50pF See Fig. 15.
Disable propagation delay (TOE to Q)	t _{PTD}		300		ns	R _L = 10kΩ(pulldown) C _L = 50pF See Fig. 15.

MV8870/MV8870-1

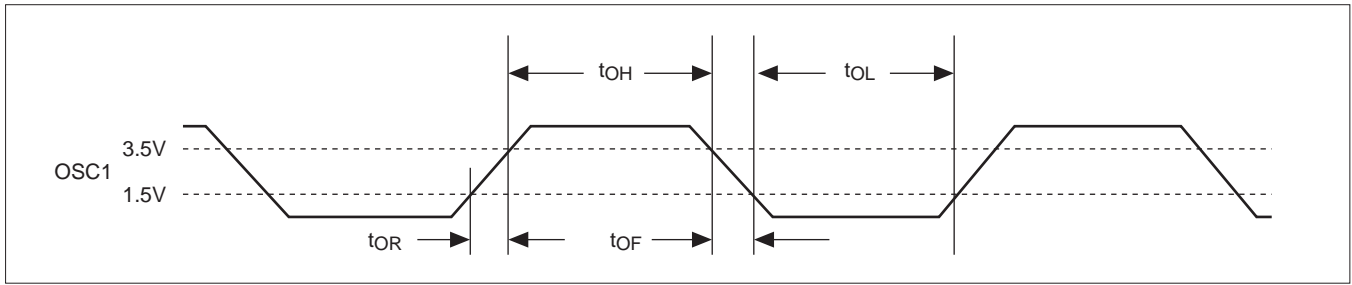

Figure 13: Timing - external oscillator input

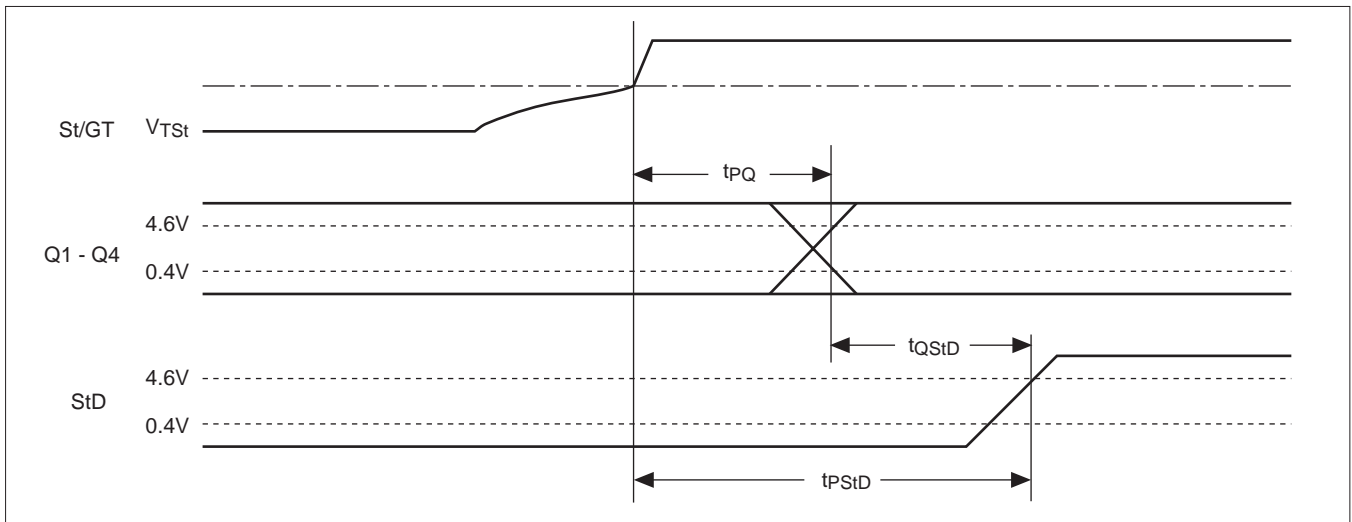

Figure 14: Timing - decoded data

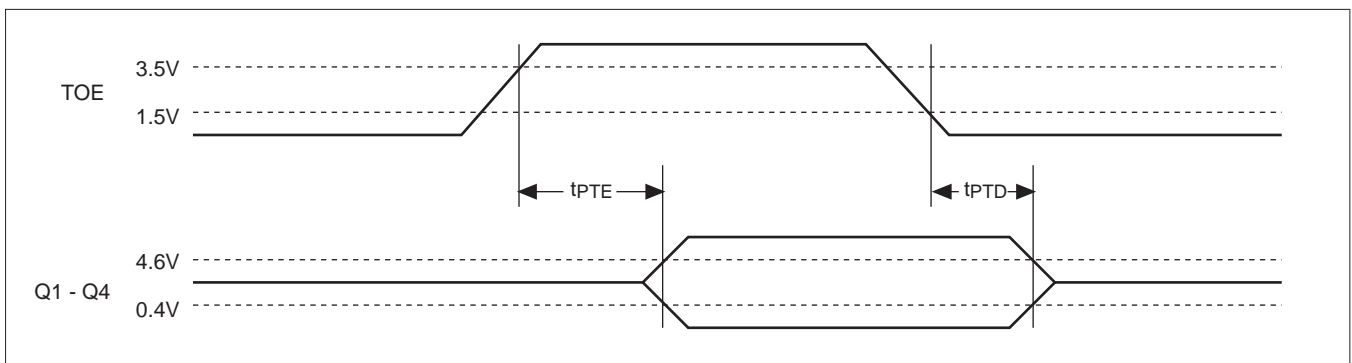

Figure 15: Timing - Output enable and disable

ABSOLUTE MAXIMUM RATINGS* Voltages are with respect to the negative power supply (V_{SS})

Parameter	Symbol	Value (MV8870)		Value (MV8870-1)		Units
		Min	Max	Min	Max	
Positive supply voltage (Pin 18)	V_{DD}		+6.0		+6.0	V
Voltage on any pin (other than supplies)	V_{MAX}	-0.3	$V_{DD} + 0.3$	-0.3	$V_{DD} + 0.3$	
Current at any pin (other than supplies)	I_{MAX}		10		10	mA
Storage temperature	T_{STG}	-65	+150	-65	+150	°C
Package power dissipation	P_P		1000†		1000†	mW

* Exceeding these ratings may cause permanent damage. Functional operation under these conditions is not implied.

† Derate parameter above +75°C at 16mW/°C, all leads soldered to board.



HEADQUARTERS OPERATIONS
GEC PLESSEY SEMICONDUCTORS
 Cheney Manor, Swindon,
 Wiltshire SN2 2QW, United Kingdom.
 Tel: (0793) 518000
 Fax: (0793) 518411

GEC PLESSEY SEMICONDUCTORS
 P.O.Box 660017,
 1500 Green Hills Road,
 Scotts Valley, California 95067-0017,
 United States of America.
 Tel (408) 438 2900
 Fax: (408) 438 5576

CUSTOMER SERVICE CENTRES

- **FRANCE & BENELUX** Les Ulis Cedex Tel: (1) 64 46 23 45 Fax: (1) 64 46 06 07
- **GERMANY** Munich Tel: (089) 3609 06-0 Fax : (089) 3609 06-55
- **ITALY** Milan Tel: (02) 66040867 Fax: (02) 66040993
- **JAPAN** Tokyo Tel: (3) 5276-5501 Fax: (3) 5276-5510
- **NORTH AMERICA Integrated Circuits and Microwave Products**, Scotts Valley, USA
 Tel (408) 438 2900 Fax: (408) 438 7023.
- **Hybrid Products**, Farmingdale, USA Tel (516) 293 8686 Fax: (516) 293 0061.
- **SOUTH EAST ASIA** Singapore Tel: 2919291 Fax: 2916455
- **SWEDEN** Johanneshov Tel: 46 8 702 97 70 Fax: 46 8 640 47 36
- **UK, EIRE, DENMARK, FINLAND & NORWAY**
 Swindon Tel: (0793) 518510 Fax : (0793) 518582

These are supported by Agents and Distributors in major countries world-wide.

© GEC Plessey Semiconductors 1993 Publication No. DS 3140 Issue No. 2.1 September 1993

This publication is issued to provide information only which (unless agreed by the Company in writing) may not be used, applied or reproduced for any purpose nor form part of any order or contract nor to be regarded as a representation relating to the products or services concerned. No warranty or guarantee express or implied is made regarding the capability, performance or suitability of any product or service. The Company reserves the right to alter without prior knowledge the specification, design or price of any product or service. Information concerning possible methods of use is provided as a guide only and does not constitute any guarantee that such methods of use will be satisfactory in a specific piece of equipment. It is the user's responsibility to fully determine the performance and suitability of any equipment using such information and to ensure that any publication or data used is up to date and has not been superseded. These products are not suitable for use in any medical products whose failure to perform may result in significant injury or death to the user. All products and materials are sold and services provided subject to the Company's conditions of sale, which are available on request.