

FEATURES

- **LOW NOISE FIGURE**
NF = 1.6 dB TYP at f = 12 GHz
- **HIGH ASSOCIATED GAIN**
GA = 9.5 dB TYP at f = 12 GHz
- **L_G = 0.3 μm, W_G = 280 μm**
- **EPITAXIAL TECHNOLOGY**
- **LOW PHASE NOISE**

DESCRIPTION

The NE71300 features a low noise figure and high associated gain through K-band by employing a recessed 0.3 micron gate and triple epitaxial technology. The active area of the chip is covered with SiO₂ and Si₃N₄ for scratch protection as well as surface stability. This device is suitable for both amplifier and oscillator applications in the consumer and industrial markets.

NEC's stringent quality assurance and test procedures ensure the highest reliability and performance.

**NOISE FIGURE & ASSOCIATED GAIN
vs. FREQUENCY**
V_{DS} = 3 V, I_{DS} = 10 mA

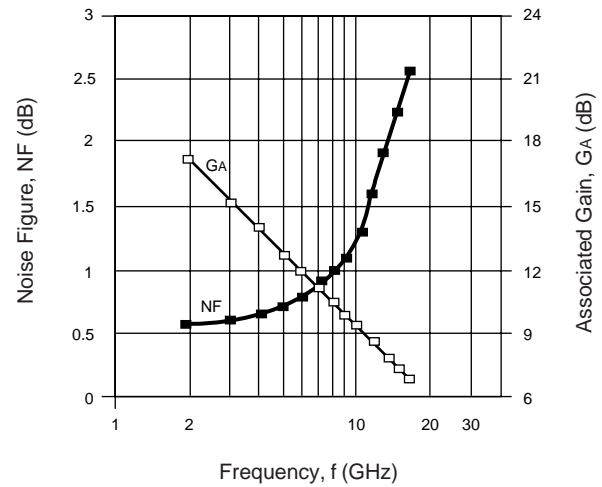

ELECTRICAL CHARACTERISTICS (T_A = 25°C)

PART NUMBER PACKAGE OUTLINE			NE71300 00 (CHIP)		
SYMBOLS	PARAMETERS AND CONDITIONS	UNITS	MIN	TYP	MAX
NFOPT ¹	Optimum Noise Figure, V _{DS} = 3 V, I _{DS} = 10 mA, f = 4 GHz f = 12 GHz	dB dB		0.6 1.6	0.7 1.8
GA ¹	Associated Gain, V _{DS} = 3 V, I _{DS} = 10 mA, f = 4 GHz f = 12 GHz	dB dB	11.5 8.5	14.0 9.5	
P _{1dB}	Output Power at 1 dB Compression, V _{DS} = 3 V, I _{DS} = 30 mA, f = 12 GHz	dBm		14.5	
I _{DSS}	Saturated Drain Current, V _{DS} = 3 V, V _{GS} = 0	mA	20	40	120
V _P	Pinch-Off Voltage, V _{DS} = 3 V, I _{DS} = 0.1 mA	V	-3.5	-1.1	-0.5
g _m	Transconductance, V _{DS} = 3 V, I _{DS} = 10 mA	mS	20	50	
I _{GSO}	Gate to Source Leakage Current at V _{GS} = -5 V	μA		1.0	10
R _{TH (CH-C)} ²	Thermal Resistance (Channel to Case)	°C/W			190

Notes:

1. RF performance is determined by packaging and testing 10 samples per wafer; wafer rejection criteria for standard devices is 2 rejects for 10 samples.
2. Chip mounted on infinite heat sink.

ABSOLUTE MAXIMUM RATINGS¹ (T_A = 25°C)

SYMBOLS	PARAMETERS	UNITS	RATINGS
V _{DS}	Drain to Source Voltage	V	5
V _{GD}	Gate to Drain Voltage	V	-6
V _{GS}	Gate to Source Voltage	V	-5
I _{DS}	Drain Current	mA	I _{DSS}
P _{IN}	RF Input (CW)	dBm	+15
T _{CH}	Channel Temperature	°C	175
T _{STG}	Storage Temperature	°C	-65 to +175
P _T ²	Total Power Dissipation	mW	400

Notes:

1. Operation in excess of any one of these parameters may result in permanent damage.
2. With chip mounted on a copper heat sink.

TYPICAL PERFORMANCE CURVES (T_A = 25 °C)

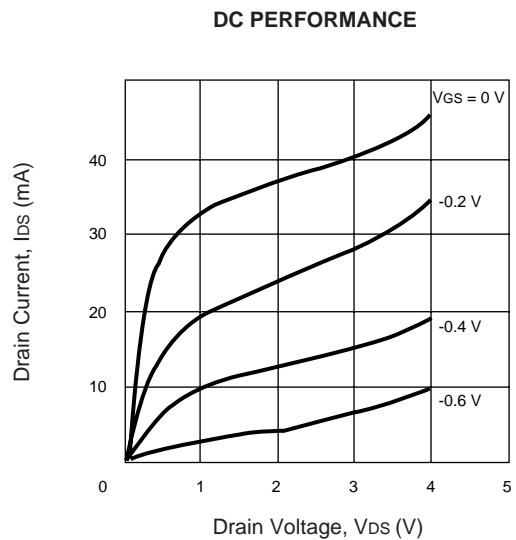
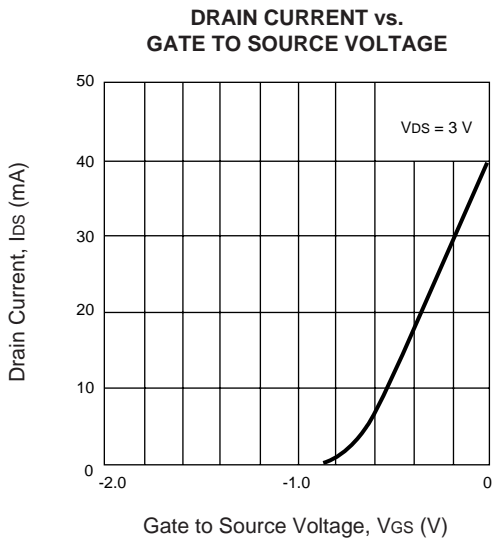
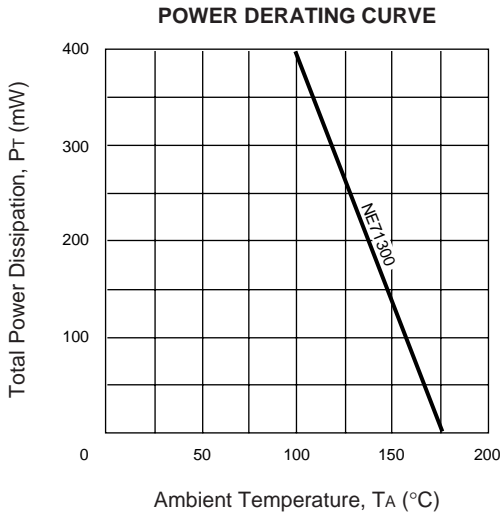

TYPICAL SCATTERING PARAMETERS¹

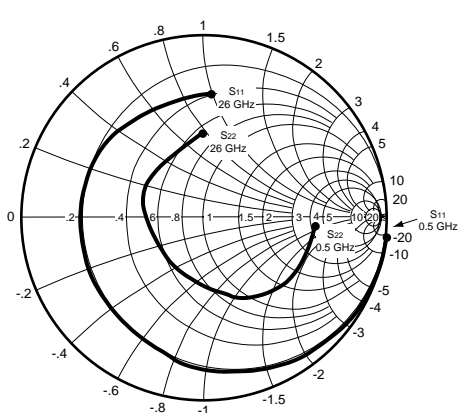

Coordinates in Ohms
Frequency in GHz
(V_{ds} = 2 V, I_d = 10 mA)

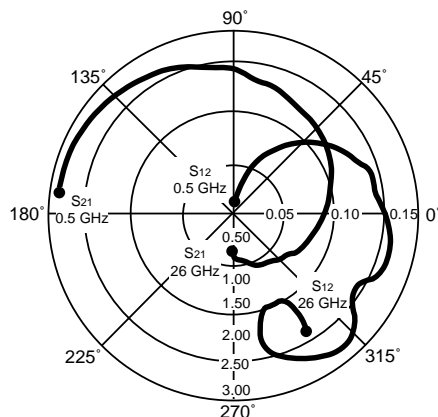

NE71300

V_{ds} = 2 V, I_d = 10 mA

FREQUENCY (GHz)	S ₁₁		S ₂₁		S ₁₂		S ₂₂		K	MAG ² (dB)
	MAG	ANG	MAG	ANG	MAG	ANG	MAG	ANG		
0.5	0.998	-7.5	2.931	172.9	0.013	84.6	0.602	-5.5	0.047	23.531
1.0	0.995	-15.0	2.922	165.9	0.026	79.9	0.600	-10.8	0.063	20.507
2.0	0.982	-29.9	2.882	152.1	0.052	69.1	0.593	-21.4	0.127	17.437
3.0	0.959	-44.4	2.823	138.0	0.075	59.1	0.581	-31.6	0.201	15.756
4.0	0.928	-58.8	2.703	124.6	0.097	48.8	0.563	-41.6	0.277	14.451
5.0	0.895	-72.7	2.652	111.2	0.113	38.4	0.541	-51.6	0.352	13.705
6.0	0.852	-86.5	2.470	97.9	0.128	28.8	0.506	-61.2	0.447	12.855
7.0	0.817	-100.5	2.384	86.2	0.141	18.8	0.472	-71.0	0.509	12.281
8.0	0.762	-113.5	2.248	73.2	0.141	8.9	0.426	-78.5	0.677	12.026
9.0	0.736	-126.3	2.108	63.8	0.147	2.4	0.396	-87.2	0.729	11.566
10.0	0.713	-139.6	2.046	51.1	0.155	-4.9	0.368	-97.7	0.767	11.206
11.0	0.702	-153.1	1.911	40.7	0.159	-14.4	0.342	-109.8	0.810	10.799
12.0	0.687	-166.7	1.842	29.2	0.156	-24.5	0.317	-124.7	0.874	10.722
13.0	0.682	-179.1	1.710	17.8	0.142	-27.6	0.298	-139.0	0.999	10.807
14.0	0.675	169.7	1.618	8.2	0.139	-31.9	0.295	-153.3	1.065	9.101
15.0	0.674	160.4	1.501	-2.5	0.138	-32.3	0.300	-165.9	1.126	8.207
16.0	0.676	152.0	1.391	-10.4	0.145	-37.8	0.309	-175.7	1.128	7.642
17.0	0.673	144.9	1.315	-19.8	0.149	-39.2	0.326	175.3	1.138	7.198
18.0	0.666	138.2	1.248	-31.4	0.161	-42.3	0.340	167.6	1.112	6.860
19.0	0.664	132.5	1.112	-36.3	0.174	-51.1	0.359	160.7	1.132	5.846
20.0	0.656	126.5	1.101	-45.1	0.160	-65.9	0.369	152.0	1.274	5.230
21.0	0.658	119.6	0.995	-51.5	0.137	-80.3	0.371	142.4	1.659	3.865
22.0	0.654	113.6	0.933	-63.7	0.097	-76.0	0.369	133.3	2.561	2.913
23.0	0.646	107.2	0.882	-71.0	0.099	-68.6	0.373	123.2	2.679	2.369
24.0	0.660	100.7	0.783	-77.6	0.098	-60.6	0.385	113.3	2.919	1.496
25.0	0.670	94.7	0.760	-86.4	0.111	-57.8	0.411	103.3	2.495	1.561
26.0	0.681	89.6	0.675	-91.4	0.130	-57.9	0.446	94.5	2.220	0.919

Notes:

1. S-parameters include bond wires.

Gate: Total 2 wire (s), 2 per bond pad, 0.0298" (756 μm) long each wire.

Drain: Total 739 wire(s), 2 per bond pad, 0.0291" (739 μm) long each wire.

Source: Total 4 wire (s), 2 per side, 0.0186" (472 μm) long each wire.

Wire: 0.0007" (17.8 μm) Diameter, Gold.

2. Gain Calculations:

$$MAG = \frac{|S_{21}|}{|S_{12}|} (K \pm \sqrt{K^2 - 1})$$

When $K \leq 1$, MAG is undefined and MSG values are used. $MSG = \frac{|S_{21}|}{|S_{12}|}$, $K = \frac{1 + |\Delta|^2 - |S_{11}|^2 - |S_{22}|^2}{2 |S_{12} S_{21}|}$, $\Delta = S_{11} S_{22} - S_{21} S_{12}$

MAG = Maximum Available Gain

MSG = Maximum Stable Gain

TYPICAL SCATTERING PARAMETERS¹

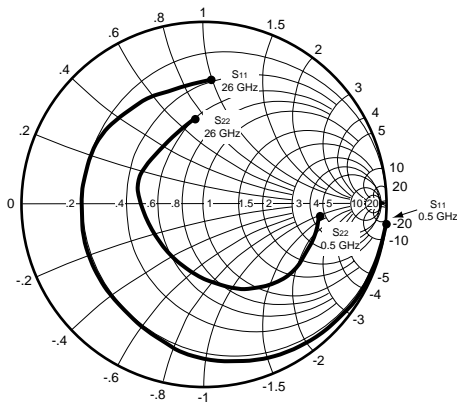

Coordinates in Ohms
Frequency in GHz
(V_{DS} = 3 V, I_D = 10 mA)

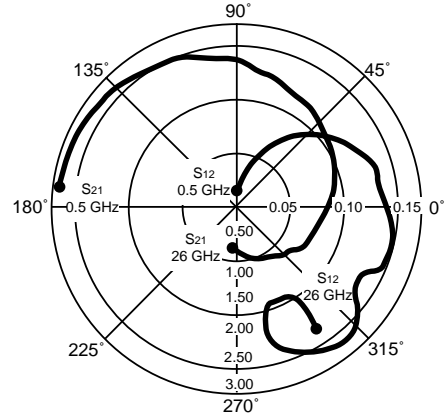

NE71300

V_{DS} = 3 V, I_D = 10 mA

FREQUENCY (GHz)	S ₁₁		S ₂₁		S ₁₂		S ₂₂		K	MAG ² (dB)
	MAG	ANG	MAG	ANG	MAG	ANG	MAG	ANG		
0.500	0.998	-7.5	2.926	172.9	0.013	84.4	0.637	-5.2	0.050	23.523
1.000	0.995	-15.0	2.917	165.9	0.025	79.6	0.635	-10.3	0.068	20.670
2.000	0.982	-29.8	2.877	152.1	0.050	69.2	0.628	-20.5	0.130	17.600
3.000	0.958	-44.3	2.820	138.0	0.071	59.1	0.616	-30.1	0.212	15.990
4.000	0.927	-58.7	2.698	124.6	0.092	49.0	0.598	-39.7	0.287	14.673
5.000	0.894	-72.6	2.650	111.2	0.108	38.6	0.576	-49.2	0.363	13.898
6.000	0.851	-86.4	2.468	97.8	0.121	29.0	0.541	-58.3	0.464	13.096
7.000	0.816	-100.3	2.382	86.1	0.134	19.1	0.507	-67.5	0.527	12.498
8.000	0.761	-113.3	2.250	73.2	0.134	9.1	0.463	-74.5	0.698	12.251
9.000	0.734	-126.0	2.105	63.7	0.138	2.7	0.434	-82.6	0.762	11.834
10.000	0.712	-139.3	2.051	51.1	0.146	-4.4	0.406	-92.3	0.796	11.476
11.000	0.700	-152.8	1.915	40.6	0.150	-13.4	0.378	-103.5	0.843	11.061
12.000	0.685	-166.4	1.850	29.2	0.147	-23.4	0.350	-117.1	0.913	10.999
13.000	0.681	-178.7	1.725	17.7	0.134	-26.4	0.329	-130.2	1.037	9.915
14.000	0.674	170.0	1.631	8.0	0.131	-30.6	0.321	-143.7	1.110	8.932
15.000	0.672	160.7	1.518	-2.7	0.130	-30.9	0.321	-156.0	1.176	8.135
16.000	0.675	152.3	1.406	-10.8	0.136	-36.1	0.329	-166.1	1.179	7.584
17.000	0.673	145.2	1.330	-20.3	0.140	-37.1	0.344	-175.4	1.182	7.193
18.000	0.666	138.5	1.268	-31.9	0.152	-40.0	0.360	176.2	1.138	6.953
19.000	0.664	132.8	1.124	-37.3	0.164	-48.4	0.379	168.5	1.167	5.886
20.000	0.658	126.8	1.114	-46.0	0.153	-62.9	0.388	159.5	1.290	5.392
21.000	0.659	119.8	1.004	-52.7	0.131	-77.1	0.389	149.4	1.692	3.993
22.000	0.655	113.8	0.945	-65.1	0.094	-73.3	0.386	140.2	2.566	3.095
23.000	0.647	107.2	0.890	-72.3	0.095	-65.6	0.387	129.8	2.724	2.509
24.000	0.662	100.7	0.787	-79.3	0.095	-57.4	0.398	119.5	2.936	1.626
25.000	0.672	94.7	0.764	-88.1	0.109	-54.5	0.420	109.0	2.479	1.691
26.000	0.682	89.6	0.676	-93.4	0.127	-54.8	0.454	99.4	2.231	1.004

Notes:

- S-parameters include bond wires.
 Gate: Total 2 wire (s), 2 per bond pad, 0.0298" (756 μm) long each wire.
 Drain: Total 739 wire(s), 2 per bond pad, 0.0291" (739 μm) long each wire.
 Source: Total 4 wire (s), 2 per side, 0.0186" (472 μm) long each wire.
 Wire: 0.0007" (17.8 μm) Diameter, Gold.

2. Gain Calculations:

$$MAG = \frac{|S_{21}|}{|S_{12}|} (K \pm \sqrt{K^2 - 1})$$

When $K \leq 1$, MAG is undefined and MSG values are used. $MSG = \frac{|S_{21}|}{|S_{12}|}$, $K = \frac{1 + |\Delta|^2 - |S_{11}|^2 - |S_{22}|^2}{2 |S_{12} S_{21}|}$, $\Delta = S_{11} S_{22} - S_{21} S_{12}$

MAG = Maximum Available Gain
 MSG = Maximum Stable Gain

TYPICAL SCATTERING PARAMETERS¹

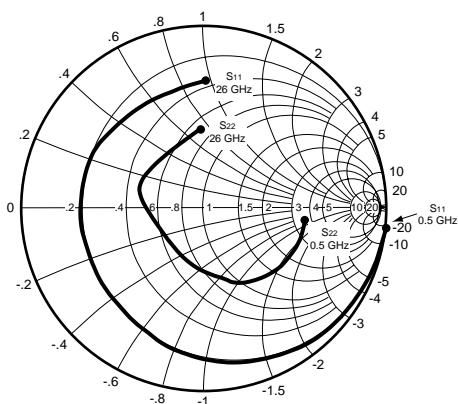

Coordinates in Ohms
Frequency in GHz
(V_{DS} = 3 V, I_D = 30 mA)

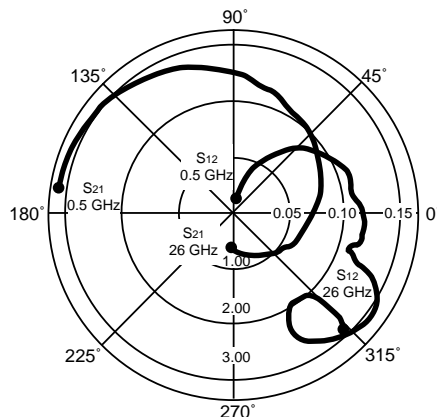

NE71300

V_{DS} = 3 V, I_D = 30 mA

FREQUENCY (GHz)	S ₁₁		S ₂₁		S ₁₂		S ₂₂		K	MAG ² (dB)
	MAG	ANG	MAG	ANG	MAG	ANG	MAG	ANG		
0.500	0.998	-8.3	3.738	172.5	0.011	84.3	0.574	-5.3	0.049	25.312
1.000	0.993	-16.5	3.718	165.1	0.021	79.7	0.571	-10.6	0.080	22.481
2.000	0.976	-32.7	3.640	150.6	0.042	68.8	0.562	-21.0	0.153	19.379
3.000	0.946	-48.2	3.527	136.0	0.060	59.1	0.548	-30.8	0.242	17.693
4.000	0.909	-63.3	3.341	122.4	0.077	49.1	0.529	-40.6	0.327	16.374
5.000	0.870	-77.7	3.236	108.9	0.089	39.1	0.507	-50.4	0.411	15.606
6.000	0.821	-92.2	2.984	95.6	0.100	30.1	0.475	-59.5	0.522	14.748
7.000	0.783	-106.9	2.845	83.8	0.109	20.5	0.443	-68.6	0.597	14.167
8.000	0.725	-120.4	2.646	71.1	0.107	11.5	0.401	-74.3	0.808	13.932
9.000	0.702	-133.6	2.449	61.8	0.109	7.0	0.376	-80.9	0.888	13.516
10.000	0.687	-146.9	2.354	49.7	0.116	1.5	0.352	-89.4	0.911	13.073
11.000	0.685	-159.8	2.179	39.7	0.119	-6.1	0.325	-99.7	0.958	12.627
12.000	0.680	-172.3	2.085	28.9	0.117	-14.8	0.294	-113.5	1.029	11.467
13.000	0.683	176.7	1.935	18.0	0.109	-15.5	0.272	-128.3	1.147	10.163
14.000	0.679	166.5	1.829	8.8	0.109	-18.8	0.264	-143.9	1.206	9.505
15.000	0.677	157.8	1.701	-1.5	0.111	-18.0	0.270	-158.7	1.251	8.838
16.000	0.675	149.5	1.582	-9.4	0.118	-22.5	0.285	-169.7	1.245	8.294
17.000	0.670	142.1	1.497	-18.7	0.125	-22.5	0.310	-179.3	1.217	7.969
18.000	0.662	134.9	1.423	-30.3	0.143	-25.0	0.334	173.5	1.107	7.983
19.000	0.658	128.7	1.259	-35.4	0.159	-35.1	0.358	167.2	1.101	7.052
20.000	0.655	122.2	1.245	-44.0	0.149	-50.8	0.373	159.0	1.183	6.633
21.000	0.663	115.2	1.117	-50.3	0.127	-65.2	0.373	149.9	1.540	5.111
22.000	0.661	109.6	1.045	-62.5	0.095	-60.3	0.363	141.1	2.279	4.053
23.000	0.658	104.2	0.982	-69.4	0.097	-53.5	0.355	130.3	2.416	3.412
24.000	0.675	99.0	0.873	-76.3	0.100	-46.2	0.359	118.5	2.532	2.546
25.000	0.686	94.4	0.847	-85.0	0.116	-44.4	0.381	106.1	2.126	2.611
26.000	0.698	90.5	0.756	-90.2	0.136	-45.0	0.418	95.0	1.884	2.034

Notes:

1. S-parameters include bond wires.

Gate: Total 2 wire (s), 2 per bond pad, 0.0298" (756 μm) long each wire.

Drain: Total 739 wire(s), 2 per bond pad, 0.0291" (739 μm) long each wire.

Source: Total 4 wire (s), 2 per side, 0.0186" (472 μm) long each wire.

Wire: 0.0007" (17.8 μm) Diameter, Gold.

2. Gain Calculations:

$$MAG = \frac{|S_{21}|}{|S_{12}|} \left(K \pm \sqrt{K^2 - 1} \right). \text{ When } K \leq 1, \text{ MAG is undefined and MSG values are used. } MSG = \frac{|S_{21}|}{|S_{12}|}, K = \frac{1 + |\Delta|^2 - |S_{11}|^2 - |S_{22}|^2}{2 |S_{12} S_{21}|}, \Delta = S_{11} S_{22} - S_{21} S_{12}$$

MAG = Maximum Available Gain

MSG = Maximum Stable Gain

NE71300

TYPICAL SCATTERING PARAMETERS¹

NE71300

V_{DS} = 4 V, I_D = 10 mA

FREQUENCY (GHz)	S ₁₁		S ₂₁		S ₁₂		S ₂₂		K	MAG ² (dB)
	MAG	ANG	MAG	ANG	MAG	ANG	MAG	ANG		
0.500	0.998	-7.5	2.874	172.9	0.012	83.7	0.658	-5.0	0.060	23.793
1.000	0.994	-14.9	2.866	165.9	0.024	79.5	0.656	-10.0	0.081	20.771
2.000	0.981	-29.7	2.828	152.1	0.048	69.4	0.649	-19.8	0.137	17.702
3.000	0.958	-44.1	2.774	138.0	0.069	59.1	0.637	-29.2	0.219	16.043
4.000	0.927	-58.4	2.654	124.6	0.089	49.2	0.620	-38.4	0.295	14.745
5.000	0.894	-72.2	2.610	111.3	0.105	38.8	0.598	-47.7	0.372	13.955
6.000	0.851	-86.0	2.432	97.8	0.118	29.1	0.564	-56.4	0.477	13.141
7.000	0.816	-99.9	2.348	86.1	0.130	19.4	0.531	-65.3	0.540	12.568
8.000	0.761	-112.9	2.223	73.2	0.130	9.2	0.488	-72.0	0.717	12.330
9.000	0.735	-125.6	2.078	63.6	0.133	2.9	0.460	-79.8	0.783	11.938
10.000	0.711	-138.9	2.030	51.1	0.141	-3.9	0.433	-89.1	0.817	11.583
11.000	0.700	-152.3	1.895	40.4	0.144	-12.9	0.405	-99.7	0.871	11.192
12.000	0.685	-165.9	1.834	29.1	0.141	-22.7	0.376	-112.6	0.944	11.142
13.000	0.681	-178.2	1.716	17.5	0.129	-25.5	0.353	-124.9	1.069	9.635
14.000	0.674	170.5	1.621	7.8	0.126	-29.6	0.342	-138.1	1.147	8.767
15.000	0.672	161.2	1.512	-3.0	0.126	-29.8	0.341	-150.0	1.202	8.073
16.000	0.675	152.7	1.402	-11.3	0.131	-35.3	0.348	-160.0	1.213	7.511
17.000	0.673	145.5	1.328	-20.8	0.134	-35.7	0.362	-169.7	1.219	7.138
18.000	0.666	138.8	1.269	-32.5	0.146	-38.3	0.379	-178.5	1.162	6.948
19.000	0.665	133.1	1.120	-38.2	0.158	-46.6	0.397	173.5	1.191	5.864
20.000	0.659	127.0	1.111	-46.8	0.148	-61.0	0.406	164.1	1.311	5.414
21.000	0.661	120.0	0.999	-53.7	0.128	-75.2	0.405	153.9	1.708	4.020
22.000	0.657	114.1	0.943	-66.3	0.093	-70.9	0.402	144.6	2.547	3.168
23.000	0.649	107.4	0.886	-73.6	0.093	-63.5	0.402	133.9	2.738	2.557
24.000	0.664	100.9	0.782	-80.9	0.093	-55.0	0.410	123.5	2.962	1.651
25.000	0.673	94.8	0.760	-89.7	0.108	-52.3	0.432	112.6	2.466	1.735
26.000	0.684	89.6	0.669	-95.0	0.126	-52.5	0.464	102.8	2.221	1.014

Notes:

1. S-parameters include bond wires.

Gate: Total 2 wire (s), 2 per bond pad, 0.0298" (756 μm) long each wire.

Drain: Total 739 wire(s), 2 per bond pad, 0.0291" (739 μm) long each wire.

Source: Total 4 wire (s), 2 per side, 0.0186" (472 μm) long each wire.

Wire: 0.0007" (17.8 μm) Diameter, Gold.

2. Gain Calculations:

$$MAG = \frac{|S_{21}|}{|S_{12}|} (K \pm \sqrt{K^2 - 1})$$

When $K \leq 1$, MAG is undefined and MSG values are used. $MSG = \frac{|S_{21}|}{|S_{12}|}$, $K = \frac{1 + |\Delta|^2 - |S_{11}|^2 - |S_{22}|^2}{2 |S_{12} S_{21}|}$, $\Delta = S_{11} S_{22} - S_{21} S_{12}$

MAG = Maximum Available Gain

MSG = Maximum Stable Gain

OUTLINE DIMENSIONS (Units in μm)

NE71300 (CHIP)
(Units in μm)

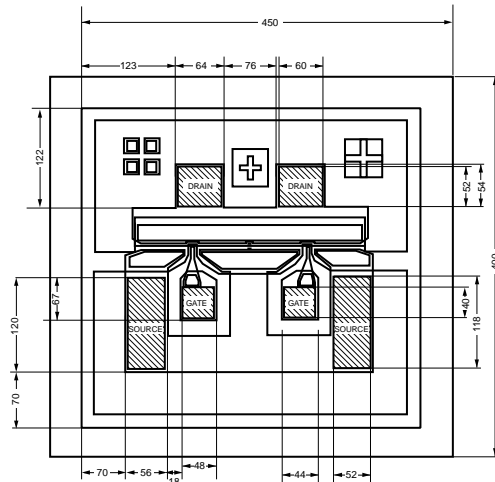

Note: All dimensions are typical unless otherwise stated.

ORDERING INFORMATION

PART NUMBER	I _{DSS} SELECTION (mA)
NE71300	20 to 120 (Standard)
NE71300N	20 to 50
NE71300M	50 to 80
NE71300L	80 to 120

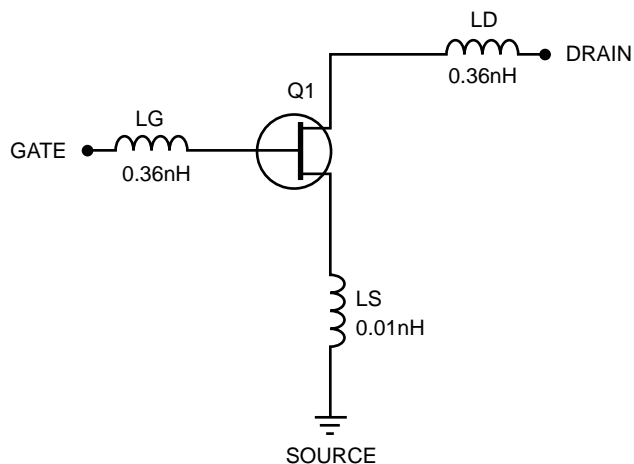
NE71300(L) NONLINEAR MODEL**SCHEMATIC****FET NONLINEAR MODEL PARAMETERS ⁽¹⁾**

Parameters	Q1	Parameters	Q1
VTO	-2.04	RG	6
VTOSC	0	RD	2
ALPHA	2.5	RS	2
BETA	0.03145	RGMET	0
GAMMA	0.115	KF	0
GAMMADC	0.06	AF	1
Q	1.7	TNOM	27
DELTA	0.42	XTI	3
VBI	1	EG	1.43
IS	7.3e-12	VTOTC	0
N	1.2	BETATCE	0
RIS	0	FFE	1
RID	0		
TAU	6e-12		
CDS	0.15e-12		
RDB	2000		
CBS	1e-9		
CGSO	0.55e-12		
CGDO	0.04e-12		
DELTA1	0.3		
DELTA2	0.2		
FC	0.5		
VBR	Infinity		

UNITS

Parameter	Units
time	seconds
capacitance	farads
inductance	henries
resistance	ohms
voltage	volts
current	amps

MODEL RANGE

Frequency: 0.5 to 20 GHz
 Bias: $V_{DS} = 2\text{ V to }4\text{ V}$, $I_D = 10\text{ mA to }30\text{ mA}$
 Date: 2/10/97

(1) Series IV Libra TOM Model

NE71300(N) NONLINEAR MODEL

SCHEMATIC

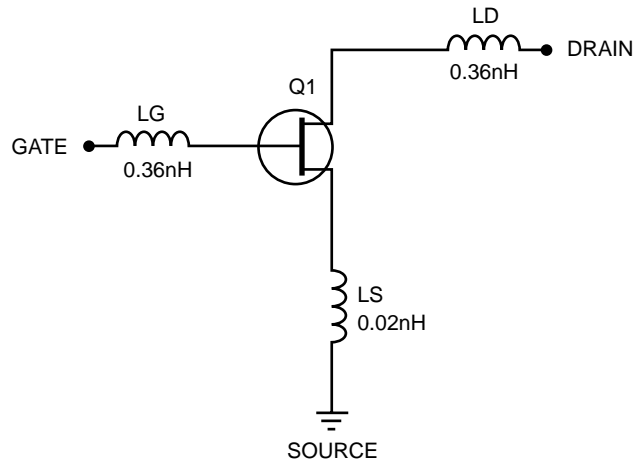

FET NONLINEAR MODEL PARAMETERS (1)

Parameters	Q1	Parameters	Q1
VTO	-1.04	RG	6
VTOSC	0	RD	2
ALPHA	4.5	RS	2
BETA	0.0409	RGMET	0
GAMMA	0.082	KF	0
GAMMADC	0.05	AF	1
Q	1.9	TNOM	27
DELTA	0.42	XTI	3
VBI	1	EG	1.43
IS	7.3e-12	VTOTC	0
N	1.2	BETATCE	0
RIS	0	FFE	1
RID	0		
TAU	6e-12		
CDS	0.15e-12		
RDB	2000		
CBS	1e-9		
CGSO	0.5e-12		
CGDO	0.04e-12		
DELTA1	0.3		
DELTA2	0.2		
FC	0.5		
VBR	Infinity		

(1) Series IV Libra TOM Model

UNITS

Parameter	Units
time	seconds
capacitance	farads
inductance	henries
resistance	ohms
voltage	volts
current	amps

MODEL RANGE

Frequency: 0.5 to 20 GHz
 Bias: $V_{DS} = 2\text{ V to }4\text{ V}$, $I_D = 10\text{ mA to }30\text{ mA}$
 Date: 2/10/97

EXCLUSIVE NORTH AMERICAN AGENT FOR **NEC** RF, MICROWAVE & OPTOELECTRONIC SEMICONDUCTORS

CEL CALIFORNIA EASTERN LABORATORIES • Headquarters • 4590 Patrick Henry Drive • Santa Clara, CA 95054-1817 • (408) 988-3500 • Telex 34-6393 • FAX (408) 988-0279
 24-Hour Fax-On-Demand: 800-390-3232 (U.S. and Canada only) • Internet: <http://WWW.CEL.COM>

DATA SUBJECT TO CHANGE WITHOUT NOTICE

PRINTED IN USA ON RECYCLED PAPER -9/98