

4-Channel Electronic Volume with Input Selector

■ GENERAL DESCRIPTION

The **NJW1195A** is a 4-channel electronic volume with 4-in 2-out stereo audio selector. It performs low noise and low distortion characteristics with resistance ladder circuit.

The **NJW1195A** is also available for 2-channel differential transmission electronic volume with 2-in 1-out stereo audio selector by a differential transmission select function.

All of functions are controlled via three-wired serial bus. Selectable 4-Chip address is available for using four chips on same serial bus line.

It's suitable for two-channel stereo system and or multi-channel audio system.

At the volume attenuated, the **NJW1195A** improves low distortion compared with NJW1195. Furthermore, the **NJW1195A** supports both single power supply operation and dual power supply operation.

■ PACKAGE OUTLINE



NJW1195AV

■ FEATURES

- Operating Voltage
 - Dual power supply : ± 3.5 to ± 7.5 V
 - Single power supply : $+7.0$ to $+15$ V
- 3-Wired Serial Control
- Selectable 4-Chip Address
- Low Output Noise
- Low Distortion
- 4in 2out Stereo Signal Selector
- Volume
 - $+31.5$ to -95 dB / 0.5 dB step, Mute
 - -120 dB typ.
- Differential transmission select function
- Channel Separation
- Zero Cross Detection
- Bi-CMOS Technology
- Package Outline
 - SSOP32

■ BLOCK DIAGRAM

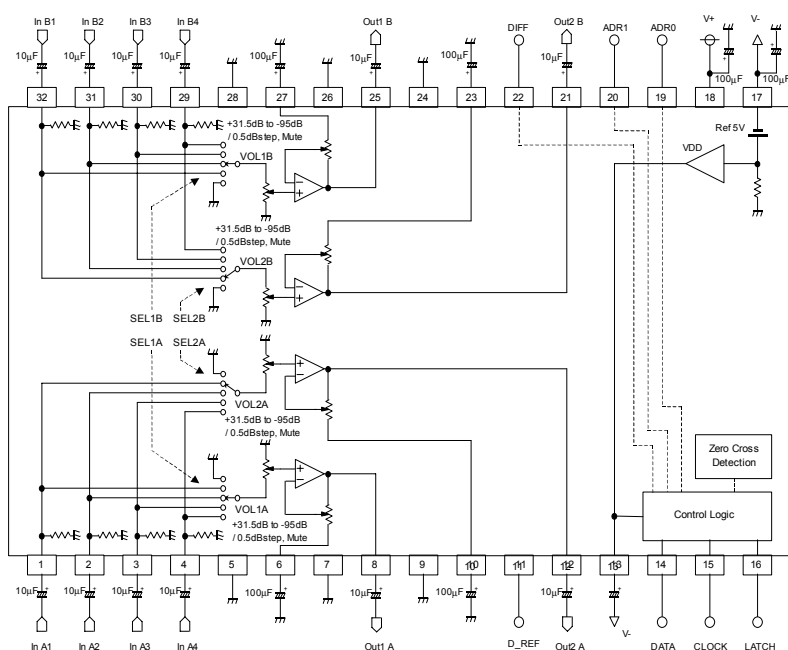

NJW1195A

■ ABSOLUTE MAXIMUM RATING (Ta=25°C)

PARAMETER	SYMBOL	RATING	UNIT
Power Supply Voltage	V _{+/-}	+8/-8	V
Maximum Input Voltage	V _{IM}	V _{+/-}	V
Power Dissipation	P _D	800 NOTE: EIA/JEDEC STANDARD Test board (76.2x114.3x1.6mm, 2layer, FR-4) mounting	mW
Operating Temperature Range	Topr	-40 ~ +85	°C
Storage Temperature Range	Tstg	-40 ~ +125	°C

■ ELECTRICAL CHARACTERISTICS (Ta=25°C, V_{+/-}=±7V, R_L=47kΩ, VOL=0dB)

PARAMETER	SYMBOL	TEST CONDITION	MIN.	TYP.	MAX.	UNIT
◆ Power Supply						
Operating Voltage	V _{+/-}		± 3.5	± 7.0	± 7.5	V
Supply Current 1	I _{CC}	No signal	-	9	15	mA
Supply Current 2	I _{EE}	No signal	-	9	15	mA
◆ Input/Output Characteristics (Output)						
Maximum Output Voltage	V _{OM}	f=1kHz, THD=1% VOL=0dB	3.6	4.2	-	Vrms
Voltage Gain 1	G _{V1}	V _{IN} =2Vrms, f=1kHz VOL=0dB	-0.5	0	0.5	dB
Voltage Gain 2	G _{V2}	V _{IN} =100mVrms, f=1kHz VOL=+15dB	+14	+15	+16	dB
Voltage Gain Error 1	ΔG _{V1}	V _{IN} =2Vrms, f=1kHz VOL=0dB	-0.5	0	0.5	dB
Voltage Gain Error 2	ΔG _{V2}	f=1kHz, V _{IN} =2Vrms VOL=-60dB	-1.0	0	1.0	dB
Maximum Attenuation	A _{TT}	f=1kHz, V _{IN} =2Vrms VOL=-95dB, A-weight	-	-95	-	dB
Mute level	Mute	f=1kHz, V _{IN} =2Vrms VOL=Mute, A-weight	-	-120	-	dB
Cross Talk 1	CT1	f=1kHz, V _{IN} =2Vrms, A-weight VOL=0dB, R _g =0Ω	-	-120	-	dB
Cross Talk 2	CT2	f=20kHz, V _{IN} =2Vrms VOL=0dB, R _g =0Ω	-	-100	-	dB
Channel Separation 1	CS1	f=1kHz, V _{IN} =2Vrms, A-weight VOL=0dB, R _g =0Ω, Out1 vs. Out2	-	-120	-90	dB
Channel Separation 2	CS2	f=20kHz, V _{IN} =2Vrms VOL=0dB, R _g =0Ω, Out1 vs. Out2	-	-100	-	dB
Channel Separation 3	CS3	f=1kHz, V _{IN} =2Vrms, A-weight VOL=0dB, R _g =0Ω, Out A vs. Out B	-	-120	-90	dB
Channel Separation 4	CS4	f=20kHz, V _{IN} =2Vrms VOL=0dB, R _g =0Ω, Out A vs. Out B	-	-100	-	dB
Input Impedance *	R _{IN}	Select Channel Input Terminal	12.0	16.7	-	kΩ

* Input Impedance is reduced by half (9.1kΩ typ.) when input selector 1 (SEL1) and input selector 2 (SEL2) chose the same input.

■ ELECTRICAL CHARACTERISTICS (Ta=25°C, V⁺/V⁻=±7V, RL=47kΩ, Volume=0dB)

PARAMETER	SYMBOL	TEST CONDITION	MIN.	TYP.	MAX.	UNIT
◆ Input/Output Characteristics (Output)						
Output Noise1	V _{NO1}	Volume=0dB, Rg=0, A-weight	-	-118 (1.26μ)	-100 (10μ)	dBV (Vrms)
Output Noise2	V _{NO2}	Volume=-95dB, Rg=0, A-weight	-	-118 (1.26μ)	-	dBV (Vrms)
Total Harmonic Distortion 1	T.H.D.1	f=1kHz, V _{IN} =200mVrms, Volume=0dB, BW=400Hz-30kHz	-	0.001	-	%
Total Harmonic Distortion 2	T.H.D.2	f=10kHz, V _{IN} =200mVrms, Volume=0dB, BW=400Hz-30kHz	-	0.001	-	%
Total Harmonic Distortion 3	T.H.D.3	f=1kHz, V _{IN} =2Vrms, Volume=0dB, BW=400Hz-30kHz	-	0.001	-	%
Total Harmonic Distortion 4	T.H.D.4	f=10kHz, V _{IN} =2Vrms, Volume=0dB, BW=400Hz-30kHz	-	0.001	-	%
Total Harmonic Distortion 5	T.H.D.5	f=1kHz, V _{IN} =200mVrms, Volume=+15dB, BW=400Hz-30kHz	-	0.001	-	%
Total Harmonic Distortion 6	T.H.D.6	f=10kHz, V _{IN} =200mVrms, Volume=+15dB, BW=400Hz-30kHz	-	0.0015	-	%
Total Harmonic Distortion 7	T.H.D.7	f=1kHz, V _{IN} =2Vrms, Volume=-24dB, BW=400Hz-30kHz	-	0.003	0.01	%
Total Harmonic Distortion 8	T.H.D.8	f=10kHz, V _{IN} =2Vrms, Volume=-24dB, BW=400Hz-30kHz	-	0.003	-	%
Total Harmonic Distortion 9	T.H.D.9	f=1kHz, V _{IN} =1Vrms, Volume=0dB, BW=400Hz-30kHz, Differential transmission	-	0.0003	-	%
Total Harmonic Distortion 10	T.H.D.10	f=10kHz, V _{IN} =1Vrms, Volume=0dB, BW=400Hz-30kHz, Differential transmission	-	0.0003	-	%
◆ Logic Control Characteristics						
High Level Input Voltage	V _{IH}	DATA, CLOCK, LATCH, ADR0, ADR1, DIFF Terminal Input	2.5	-	V ⁺	V
Low Level Input Voltage	V _{IL}	DATA, CLOCK, LATCH, ADR0, ADR1, DIFF Terminal Input	0	-	1.5	V

[CAUTION]

The specifications on this databook are only given for information, without any guarantee as regards either mistakes or omissions. The application circuits in this databook are described only to show representative usages of the product and not intended for the guarantee or permission of any right including the industrial rights.