

Features

- Output: 384 output channels
- 8-bit resolution /256 gray scales
- Dot inversion with polarity control
- V1 ~ V10 for adjusting Gamma correction
- Power for analog circuit: 7 ~ 10V
- Output dynamic range: 0.1V ~ AVDD-0.1
- Power consumption of analog circuit: 6mA
- Operating frequency: 70MHz(Vcc:3.0V~3.6V)
45MHz(Vcc:2.5V~3.0V)
- Output deviation: ±2mv
- Data inversion for reducing EMI
- Cascade function with bi-direction shift control
- CMOS silicon gate (p-type substrate)
- TCP package

General Description

The NT3980 is a data driver IC for a color TFT LCD panel, XGA and SXGA applications. It receives 8 bit per-pixel digital display data, and generates output voltage for 256 grayscales, enabling a maximum of 16.77M display colors. For better performance, dot inversion and a wide range voltage output, 10V, are designed in this chip, and for reducing EMI, data inversion control is used. This chip supplies 10 sections of voltage-reference for Gamma correction.

Block diagram

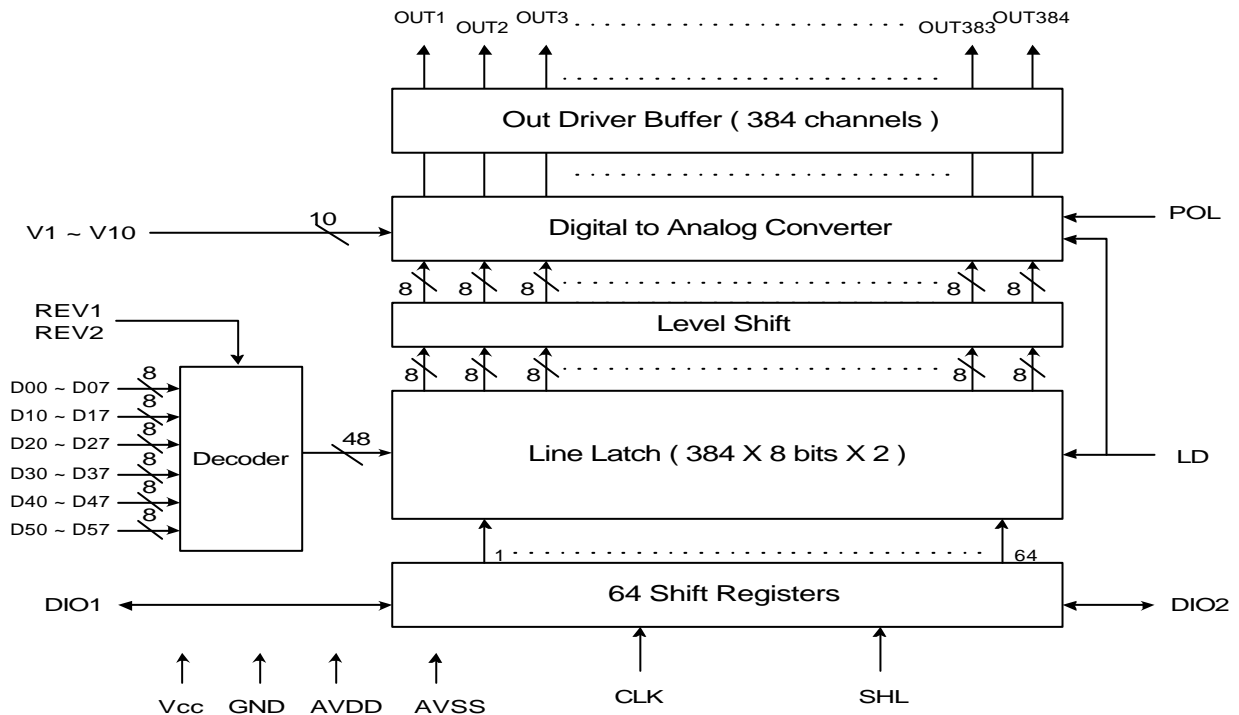

NT3980 TCP (Top view)

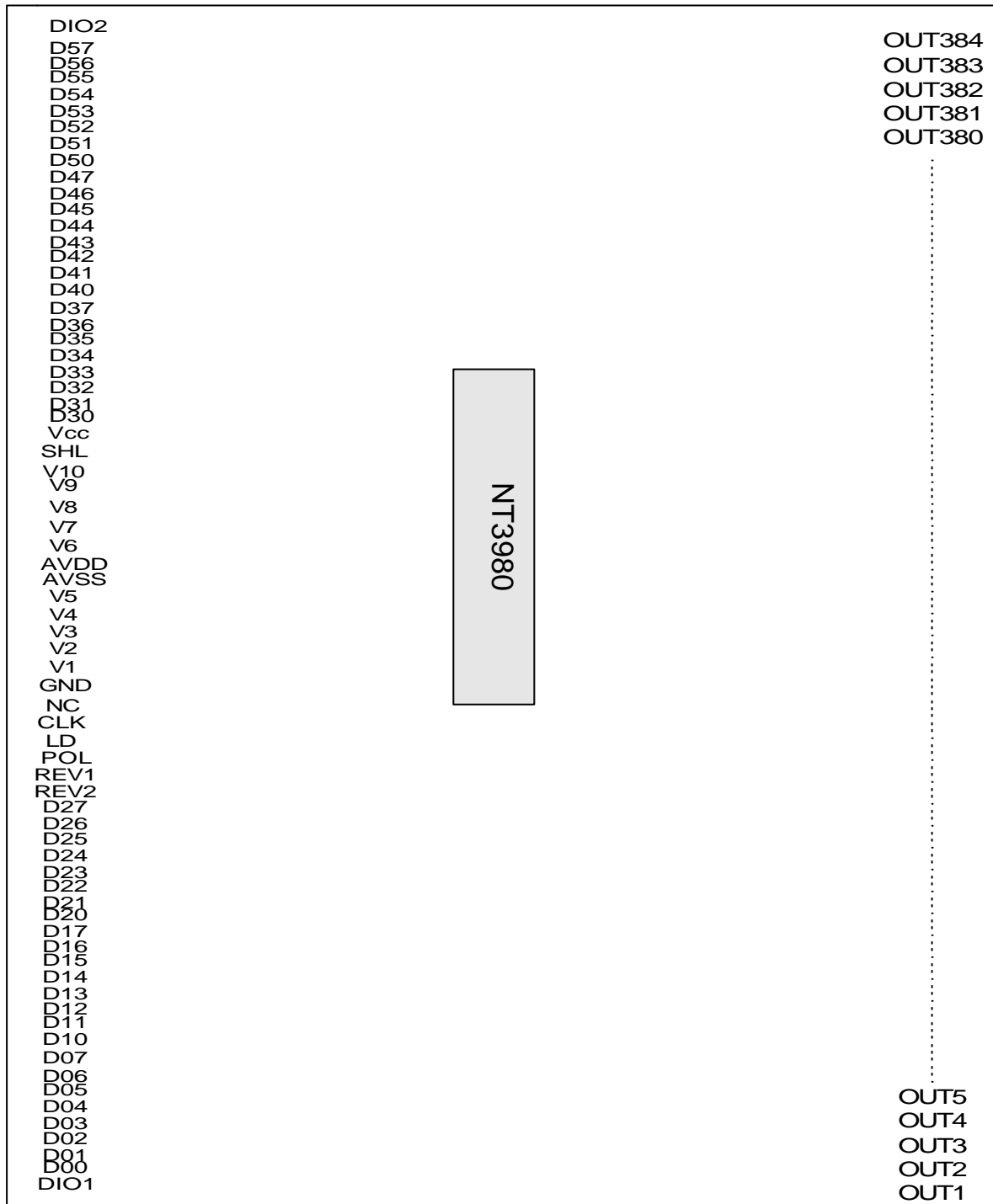

Pin Description

Designation	I/O	Description												
D07 ~ D00 D17 ~ D10 D27 ~ D20 D37 ~ D30 D47 ~ D40 D57 ~ D50	I	Data input. For six 8-bit data, 2 pixels, or color data (R, G, B) DX7 : MSB; DX0 : LSB												
REV1 REV2	I	Controls whether data are inverted or not. When "REVx"=1 the data will be inverted. EX. "00" → "FF", "07" → "F8", "15" → "EA", and so on. REV1: control D0x to D2x ,REV2: control D3x to D5x . (These two pins can be connected together on TCP.)												
V1 ~ V10	I	Gamma correction reference voltage. The voltage of these pins must be AVSS< V10< V9< V8<V7<V6; V5<V4<V3<V2<V1< AVDD												
OUT1 ~ OUT384	O	Output drive signals;												
SHL	I	Selects left or right shift; SHL="1" : DIO1 OUT1,2,3,4,5,6 OUT7,8,9,10,11,12-- OUT379,380,381,382,383,384= DIO2 SHL="0" : DIO1=OUT1,2,3,4,5,6 OUT7,8,9,10,11,12 -- OUT379,380,381,382,383,384 DIO2 <table border="1" style="margin-left: 40px;"> <thead> <tr> <th>SHL</th> <th>DIO1</th> <th>DIO2</th> <th>SHIFT</th> </tr> </thead> <tbody> <tr> <td>1</td> <td>Input</td> <td>Output</td> <td>Right</td> </tr> <tr> <td>0</td> <td>Output</td> <td>Input</td> <td>Left</td> </tr> </tbody> </table>	SHL	DIO1	DIO2	SHIFT	1	Input	Output	Right	0	Output	Input	Left
SHL	DIO1	DIO2	SHIFT											
1	Input	Output	Right											
0	Output	Input	Left											
DIO1 DIO2	I/O	Start pulse signal input/output When SHL is applied high (SHL="1"), a start high-pulse on DIO1 is latched at the rising edge of the CLK. Then the data are latched serially onto internal latches at the rising edge of the CLK. After all line latches are filled with data, 64 clocks, a pulse is shifted out through the DIO2 pin at the rising edge of the CLK. This function can cascade two or more devices for dot expansion. In normal applications, the DIO2 signal of the first device is connected to the DIO1 of the second stage, the DIO2 of the second one is connected to the DIO1 of the third, and so on, like a daisy chain. In contrast, when SHL is applied low, a start pulse inputs on DIO2, and a pulse outputs through DIO1. *Remark : The input pulse-width of DIO1/2 may exceed 1 clock-cycle.												
LD	I	Latches the polarity of outputs and switches the new data to outputs. 1.At the rising edge, the pin latches the "POL" signal to control the polarity of the outputs. 2.This pin also controls the switch of the line registers that switches the new incoming data to outputs. *Remark: The LD may switch the new data to outputs at anytime even if the line data are not completely full.												
CLK	I	Clock input; latching data onto the line latches at the rising edge . After a start pulse input, display data latching is halted automatically after 64 clock cycles. *Remark: At least one CLK cycle is necessary during the high-level period of LD.												
POL	I	Polarity selector for the dot-inversion control. Available at the rising edge of LD. "POL" value is latched at the rising edge of "LD" to control the polarity of the even or odd outputs. "POL=1" indicates that even outputs are of positive polarity with a voltage range from V1~V5, and odd outputs are of negative polarity with a voltage range from V6 to V10. On the other hand, if LD receives low level "POL", even outputs are of negative polarity and odd outputs are of positive polarity. POL=1: Even outputs range from V1 ~ V5 Odd outputs range from V6 ~ V10 POL=0: Even outputs range from V6 ~ V10 Odd outputs range from V1 ~ V5												
AVDD	I	Power supply for analog circuit;												
AVSS	I	Ground pin for analog circuit												
Vcc	I	Power supply for digital circuit												
GND	I	Ground pin for digital circuit												

Power on/off sequence:

This IC is a high-voltage LCD driver, so it may be damaged by a large current flow when an incorrect power sequence is used. The recommended connection sequence is to first connect the logical power, Vcc & GND and then connect the drive power, AVDD&AVSS with V1~V10. When shutting off the power, first shut off the drive power and then the logic system, or turn off all power simultaneously.

Relationship between the order of input data and output channels

(1) SHL="1", shift right, a start pulse from DIO1

Output	OUT1	OUT2	OUT3	OUT4	OUT5	OUT6	---		OUT384
Order	First data						-->		Last data
Data	D07~D00	D17~D10	D27~D20	D37~D30	D47~D40	D57~D50	---		D57~D50

(2) SHL="0", shift left, a start pulse from DIO2

Output	OUT379	OUT380	OUT381	OUT382	OUT383	OUT384	---		OUT6
Order	First data						-->		Last data
Data	D07~D00	D17~D10	D27~D20	D37~D30	D47~D40	D57~D50	---		D57~D50

Relationship between input data and output voltage

The figure below shows the relationship among the input data and the output voltage and the polarity. The range of V1~V5 is for positive polarity, and V6 ~ V10 for negative polarity. Please refer to the following page to get the relative resistors value and voltage calculation method.

Gamma correction diagram

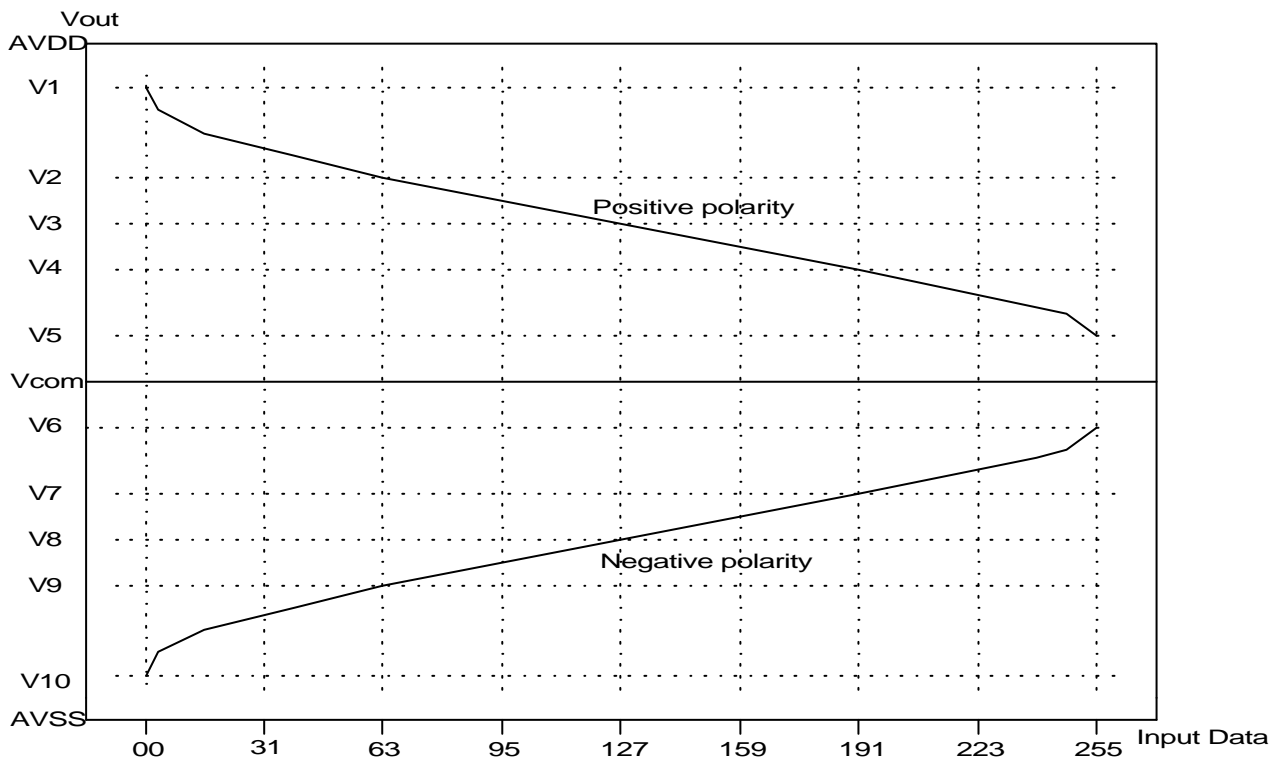

Remark : AVDD-0.1>V1>V2>V3>V4>V5>AVDD/2; AVDD/2>V6>V7>V8>V9>V10>0.1

Gamma correction resistor

V1, V10		V2, V9		V3, V8		V4, V7	
NAME	Resistor	NAME	Resistor	NAME	Resistor	NAME	Resistor
R0	210	R64	10	R128	10	R192	10
R1	210	R65	10	R129	10	R193	10
R2	150	R66	10	R130	10	R194	10
R3	150	R67	10	R131	10	R195	10
R4	110	R68	10	R132	10	R196	10
R5	110	R69	10	R133	10	R197	10
R6	80	R70	10	R134	10	R198	10
R7	80	R71	10	R135	10	R199	10
R8	80	R72	10	R136	10	R200	10
R9	80	R73	10	R137	10	R201	10
R10	80	R74	10	R138	10	R202	10
R11	80	R75	10	R139	10	R203	10
R12	50	R76	10	R140	10	R204	10
R13	50	R77	10	R141	10	R205	10
R14	50	R78	10	R142	10	R206	10
R15	50	R79	10	R143	10	R207	10
R16	40	R80	10	R144	10	R208	10
R17	40	R81	10	R145	10	R209	10
R18	40	R82	10	R146	10	R210	10
R19	40	R83	10	R147	10	R211	10
R20	40	R84	10	R148	10	R212	10
R21	40	R85	10	R149	10	R213	10
R22	40	R86	10	R150	10	R214	10
R23	40	R87	10	R151	10	R215	10
R24	30	R88	10	R152	10	R216	20
R25	30	R89	10	R153	10	R217	20
R26	30	R90	10	R154	10	R218	20
R27	30	R91	10	R155	10	R219	20
R28	30	R92	10	R156	10	R220	20
R29	30	R93	10	R157	10	R221	20
R30	30	R94	10	R158	10	R222	20
R31	30	R95	10	R159	10	R223	20
R32	30	R96	10	R160	10	R224	20
R33	30	R97	10	R161	10	R225	20
R34	30	R98	10	R162	10	R226	20
R35	30	R99	10	R163	10	R227	20
R36	30	R100	10	R164	10	R228	20
R37	30	R101	10	R165	10	R229	20
R38	20	R102	10	R166	10	R230	20
R39	20	R103	10	R167	10	R231	20
R40	20	R104	10	R168	10	R232	20
R41	20	R105	10	R169	10	R233	20
R42	20	R106	10	R170	10	R234	20
R43	20	R107	10	R171	10	R235	20
R44	20	R108	10	R172	10	R236	20
R45	20	R109	10	R173	10	R237	30
R46	20	R110	10	R174	10	R238	30
R47	20	R111	10	R175	10	R239	30
R48	20	R112	10	R176	10	R240	30
R49	20	R113	10	R177	10	R241	30
R50	20	R114	10	R178	10	R242	30
R51	20	R115	10	R179	10	R243	30
R52	20	R116	10	R180	10	R244	30
R53	20	R117	10	R181	10	R245	40
R54	20	R118	10	R182	10	R246	40
R55	20	R119	10	R183	10	R247	40
R56	20	R120	10	R184	10	R248	50
R57	20	R121	10	R185	10	R249	50
R58	20	R122	10	R186	10	R250	80
R59	20	R123	10	R187	10	R251	100
R60	20	R124	10	R188	10	R252	130
R61	20	R125	10	R189	10	R253	190
R62	20	R126	10	R190	10	R254	290
R63	20	R127	10	R191	10		

Output Voltage VS Input Data

Data(h)	Positive polarity Output Voltage	Negative polarity Output Voltage
0	V1	V10
1	$V2 + (V1 - V2) \times 267/288$	$V10 + (V9 - V10) \times 21/288$
2	$V2 + (V1 - V2) \times 246/288$	$V10 + (V9 - V10) \times 42/288$
3	$V2 + (V1 - V2) \times 231/288$	$V10 + (V9 - V10) \times 57/288$
4	$V2 + (V1 - V2) \times 216/288$	$V10 + (V9 - V10) \times 72/288$
5	$V2 + (V1 - V2) \times 205/288$	$V10 + (V9 - V10) \times 83/288$
6	$V2 + (V1 - V2) \times 194/288$	$V10 + (V9 - V10) \times 94/288$
7	$V2 + (V1 - V2) \times 186/288$	$V10 + (V9 - V10) \times 102/288$
8	$V2 + (V1 - V2) \times 178/288$	$V10 + (V9 - V10) \times 110/288$
9	$V2 + (V1 - V2) \times 170/288$	$V10 + (V9 - V10) \times 118/288$
10	$V2 + (V1 - V2) \times 162/288$	$V10 + (V9 - V10) \times 126/288$
11	$V2 + (V1 - V2) \times 154/288$	$V10 + (V9 - V10) \times 134/288$
12	$V2 + (V1 - V2) \times 146/288$	$V10 + (V9 - V10) \times 142/288$
13	$V2 + (V1 - V2) \times 141/288$	$V10 + (V9 - V10) \times 147/288$
14	$V2 + (V1 - V2) \times 136/288$	$V10 + (V9 - V10) \times 152/288$
15	$V2 + (V1 - V2) \times 131/288$	$V10 + (V9 - V10) \times 157/288$
16	$V2 + (V1 - V2) \times 126/288$	$V10 + (V9 - V10) \times 162/288$
17	$V2 + (V1 - V2) \times 122/288$	$V10 + (V9 - V10) \times 166/288$
18	$V2 + (V1 - V2) \times 118/288$	$V10 + (V9 - V10) \times 170/288$
19	$V2 + (V1 - V2) \times 114/288$	$V10 + (V9 - V10) \times 174/288$
20	$V2 + (V1 - V2) \times 110/288$	$V10 + (V9 - V10) \times 178/288$
21	$V2 + (V1 - V2) \times 106/288$	$V10 + (V9 - V10) \times 182/288$
22	$V2 + (V1 - V2) \times 102/288$	$V10 + (V9 - V10) \times 186/288$
23	$V2 + (V1 - V2) \times 98/288$	$V10 + (V9 - V10) \times 190/288$
24	$V2 + (V1 - V2) \times 94/288$	$V10 + (V9 - V10) \times 194/288$
25	$V2 + (V1 - V2) \times 91/288$	$V10 + (V9 - V10) \times 197/288$
26	$V2 + (V1 - V2) \times 88/288$	$V10 + (V9 - V10) \times 200/288$
27	$V2 + (V1 - V2) \times 85/288$	$V10 + (V9 - V10) \times 203/288$
28	$V2 + (V1 - V2) \times 82/288$	$V10 + (V9 - V10) \times 206/288$
29	$V2 + (V1 - V2) \times 79/288$	$V10 + (V9 - V10) \times 209/288$
30	$V2 + (V1 - V2) \times 76/288$	$V10 + (V9 - V10) \times 212/288$
31	$V2 + (V1 - V2) \times 73/288$	$V10 + (V9 - V10) \times 215/288$
32	$V2 + (V1 - V2) \times 70/288$	$V10 + (V9 - V10) \times 218/288$
33	$V2 + (V1 - V2) \times 67/288$	$V10 + (V9 - V10) \times 221/288$
34	$V2 + (V1 - V2) \times 64/288$	$V10 + (V9 - V10) \times 224/288$
35	$V2 + (V1 - V2) \times 61/288$	$V10 + (V9 - V10) \times 227/288$
36	$V2 + (V1 - V2) \times 58/288$	$V10 + (V9 - V10) \times 230/288$
37	$V2 + (V1 - V2) \times 55/288$	$V10 + (V9 - V10) \times 233/288$
38	$V2 + (V1 - V2) \times 52/288$	$V10 + (V9 - V10) \times 236/288$
39	$V2 + (V1 - V2) \times 50/288$	$V10 + (V9 - V10) \times 238/288$
40	$V2 + (V1 - V2) \times 48/288$	$V10 + (V9 - V10) \times 240/288$
41	$V2 + (V1 - V2) \times 46/288$	$V10 + (V9 - V10) \times 242/288$
42	$V2 + (V1 - V2) \times 44/288$	$V10 + (V9 - V10) \times 244/288$
43	$V2 + (V1 - V2) \times 42/288$	$V10 + (V9 - V10) \times 246/288$
44	$V2 + (V1 - V2) \times 40/288$	$V10 + (V9 - V10) \times 248/288$
45	$V2 + (V1 - V2) \times 38/288$	$V10 + (V9 - V10) \times 250/288$
46	$V2 + (V1 - V2) \times 36/288$	$V10 + (V9 - V10) \times 252/288$
47	$V2 + (V1 - V2) \times 34/288$	$V10 + (V9 - V10) \times 254/288$
48	$V2 + (V1 - V2) \times 32/288$	$V10 + (V9 - V10) \times 256/288$
49	$V2 + (V1 - V2) \times 30/288$	$V10 + (V9 - V10) \times 258/288$
50	$V2 + (V1 - V2) \times 28/288$	$V10 + (V9 - V10) \times 260/288$
51	$V2 + (V1 - V2) \times 26/288$	$V10 + (V9 - V10) \times 262/288$
52	$V2 + (V1 - V2) \times 24/288$	$V10 + (V9 - V10) \times 264/288$
53	$V2 + (V1 - V2) \times 22/288$	$V10 + (V9 - V10) \times 266/288$
54	$V2 + (V1 - V2) \times 20/288$	$V10 + (V9 - V10) \times 268/288$
55	$V2 + (V1 - V2) \times 18/288$	$V10 + (V9 - V10) \times 270/288$
56	$V2 + (V1 - V2) \times 16/288$	$V10 + (V9 - V10) \times 272/288$
57	$V2 + (V1 - V2) \times 14/288$	$V10 + (V9 - V10) \times 274/288$
58	$V2 + (V1 - V2) \times 12/288$	$V10 + (V9 - V10) \times 276/288$
59	$V2 + (V1 - V2) \times 10/288$	$V10 + (V9 - V10) \times 278/288$
60	$V2 + (V1 - V2) \times 8/288$	$V10 + (V9 - V10) \times 280/288$
61	$V2 + (V1 - V2) \times 6/288$	$V10 + (V9 - V10) \times 282/288$
62	$V2 + (V1 - V2) \times 4/288$	$V10 + (V9 - V10) \times 284/288$
63	$V2 + (V1 - V2) \times 2/288$	$V10 + (V9 - V10) \times 286/288$

Output Voltage VS Input Data

Data(h)	Positive polarity Output Voltage	Negative polarity Output Voltage
64	V2	V9
65	V3+(V2-V3) X 63/64	V9+(V8-V9) X 1/64
66	V3+(V2-V3) X 62/64	V9+(V8-V9) X 2/64
67	V3+(V2-V3) X 61/64	V9+(V8-V9) X 3/64
68	V3+(V2-V3) X 60/64	V9+(V8-V9) X 4/64
69	V3+(V2-V3) X 59/64	V9+(V8-V9) X 5/64
70	V3+(V2-V3) X 58/64	V9+(V8-V9) X 6/64
71	V3+(V2-V3) X 57/64	V9+(V8-V9) X 7/64
72	V3+(V2-V3) X 56/64	V9+(V8-V9) X 8/64
73	V3+(V2-V3) X 55/64	V9+(V8-V9) X 9/64
74	V3+(V2-V3) X 54/64	V9+(V8-V9) X 10/64
75	V3+(V2-V3) X 53/64	V9+(V8-V9) X 11/64
76	V3+(V2-V3) X 52/64	V9+(V8-V9) X 12/64
77	V3+(V2-V3) X 51/64	V9+(V8-V9) X 13/64
78	V3+(V2-V3) X 50/64	V9+(V8-V9) X 14/64
79	V3+(V2-V3) X 49/64	V9+(V8-V9) X 15/64
80	V3+(V2-V3) X 48/64	V9+(V8-V9) X 16/64
81	V3+(V2-V3) X 47/64	V9+(V8-V9) X 17/64
82	V3+(V2-V3) X 46/64	V9+(V8-V9) X 18/64
83	V3+(V2-V3) X 45/64	V9+(V8-V9) X 19/64
84	V3+(V2-V3) X 44/64	V9+(V8-V9) X 20/64
85	V3+(V2-V3) X 43/64	V9+(V8-V9) X 21/64
86	V3+(V2-V3) X 42/64	V9+(V8-V9) X 22/64
87	V3+(V2-V3) X 41/64	V9+(V8-V9) X 23/64
88	V3+(V2-V3) X 40/64	V9+(V8-V9) X 24/64
89	V3+(V2-V3) X 39/64	V9+(V8-V9) X 25/64
90	V3+(V2-V3) X 38/64	V9+(V8-V9) X 26/64
91	V3+(V2-V3) X 37/64	V9+(V8-V9) X 27/64
92	V3+(V2-V3) X 36/64	V9+(V8-V9) X 28/64
93	V3+(V2-V3) X 35/64	V9+(V8-V9) X 29/64
94	V3+(V2-V3) X 34/64	V9+(V8-V9) X 30/64
95	V3+(V2-V3) X 33/64	V9+(V8-V9) X 31/64
96	V3+(V2-V3) X 32/64	V9+(V8-V9) X 32/64
97	V3+(V2-V3) X 31/64	V9+(V8-V9) X 33/64
98	V3+(V2-V3) X 30/64	V9+(V8-V9) X 34/64
99	V3+(V2-V3) X 29/64	V9+(V8-V9) X 35/64
100	V3+(V2-V3) X 28/64	V9+(V8-V9) X 36/64
101	V3+(V2-V3) X 27/64	V9+(V8-V9) X 37/64
102	V3+(V2-V3) X 26/64	V9+(V8-V9) X 38/64
103	V3+(V2-V3) X 25/64	V9+(V8-V9) X 39/64
104	V3+(V2-V3) X 24/64	V9+(V8-V9) X 40/64
105	V3+(V2-V3) X 23/64	V9+(V8-V9) X 41/64
106	V3+(V2-V3) X 22/64	V9+(V8-V9) X 42/64
107	V3+(V2-V3) X 21/64	V9+(V8-V9) X 43/64
108	V3+(V2-V3) X 20/64	V9+(V8-V9) X 44/64
109	V3+(V2-V3) X 19/64	V9+(V8-V9) X 45/64
110	V3+(V2-V3) X 18/64	V9+(V8-V9) X 46/64
111	V3+(V2-V3) X 17/64	V9+(V8-V9) X 47/64
112	V3+(V2-V3) X 16/64	V9+(V8-V9) X 48/64
113	V3+(V2-V3) X 15/64	V9+(V8-V9) X 49/64
114	V3+(V2-V3) X 14/64	V9+(V8-V9) X 50/64
115	V3+(V2-V3) X 13/64	V9+(V8-V9) X 51/64
116	V3+(V2-V3) X 12/64	V9+(V8-V9) X 52/64
117	V3+(V2-V3) X 11/64	V9+(V8-V9) X 53/64
118	V3+(V2-V3) X 10/64	V9+(V8-V9) X 54/64
119	V3+(V2-V3) X 9/64	V9+(V8-V9) X 55/64
120	V3+(V2-V3) X 8/64	V9+(V8-V9) X 56/64
121	V3+(V2-V3) X 7/64	V9+(V8-V9) X 57/64
122	V3+(V2-V3) X 6/64	V9+(V8-V9) X 58/64
123	V3+(V2-V3) X 5/64	V9+(V8-V9) X 59/64
124	V3+(V2-V3) X 4/64	V9+(V8-V9) X 60/64
125	V3+(V2-V3) X 3/64	V9+(V8-V9) X 61/64
126	V3+(V2-V3) X 2/64	V9+(V8-V9) X 62/64
127	V3+(V2-V3) X 1/64	V9+(V8-V9) X 63/64

Output Voltage VS Input Data

Data(h)	Positive polarity Output Voltage	Negative polarity Output Voltage
128	V3	V8
129	V4+(V3-V4) X 63/64	V8+(V7-V8) X 1/64
130	V4+(V3-V4) X 62/64	V8+(V7-V8) X 2/64
131	V4+(V3-V4) X 61/64	V8+(V7-V8) X 3/64
132	V4+(V3-V4) X 60/64	V8+(V7-V8) X 4/64
133	V4+(V3-V4) X 59/64	V8+(V7-V8) X 5/64
134	V4+(V3-V4) X 58/64	V8+(V7-V8) X 6/64
135	V4+(V3-V4) X 57/64	V8+(V7-V8) X 7/64
136	V4+(V3-V4) X 56/64	V8+(V7-V8) X 8/64
137	V4+(V3-V4) X 55/64	V8+(V7-V8) X 9/64
138	V4+(V3-V4) X 54/64	V8+(V7-V8) X 10/64
139	V4+(V3-V4) X 53/64	V8+(V7-V8) X 11/64
140	V4+(V3-V4) X 52/64	V8+(V7-V8) X 12/64
141	V4+(V3-V4) X 51/64	V8+(V7-V8) X 13/64
142	V4+(V3-V4) X 50/64	V8+(V7-V8) X 14/64
143	V4+(V3-V4) X 49/64	V8+(V7-V8) X 15/64
144	V4+(V3-V4) X 48/64	V8+(V7-V8) X 16/64
145	V4+(V3-V4) X 47/64	V8+(V7-V8) X 17/64
146	V4+(V3-V4) X 46/64	V8+(V7-V8) X 18/64
147	V4+(V3-V4) X 45/64	V8+(V7-V8) X 19/64
148	V4+(V3-V4) X 44/64	V8+(V7-V8) X 20/64
149	V4+(V3-V4) X 43/64	V8+(V7-V8) X 21/64
150	V4+(V3-V4) X 42/64	V8+(V7-V8) X 22/64
151	V4+(V3-V4) X 41/64	V8+(V7-V8) X 23/64
152	V4+(V3-V4) X 40/64	V8+(V7-V8) X 24/64
153	V4+(V3-V4) X 39/64	V8+(V7-V8) X 25/64
154	V4+(V3-V4) X 38/64	V8+(V7-V8) X 26/64
155	V4+(V3-V4) X 37/64	V8+(V7-V8) X 27/64
156	V4+(V3-V4) X 36/64	V8+(V7-V8) X 28/64
157	V4+(V3-V4) X 35/64	V8+(V7-V8) X 29/64
158	V4+(V3-V4) X 34/64	V8+(V7-V8) X 30/64
159	V4+(V3-V4) X 33/64	V8+(V7-V8) X 31/64
160	V4+(V3-V4) X 32/64	V8+(V7-V8) X 32/64
161	V4+(V3-V4) X 31/64	V8+(V7-V8) X 33/64
162	V4+(V3-V4) X 30/64	V8+(V7-V8) X 34/64
163	V4+(V3-V4) X 29/64	V8+(V7-V8) X 35/64
164	V4+(V3-V4) X 28/64	V8+(V7-V8) X 36/64
165	V4+(V3-V4) X 27/64	V8+(V7-V8) X 37/64
166	V4+(V3-V4) X 26/64	V8+(V7-V8) X 38/64
167	V4+(V3-V4) X 25/64	V8+(V7-V8) X 39/64
168	V4+(V3-V4) X 24/64	V8+(V7-V8) X 40/64
169	V4+(V3-V4) X 23/64	V8+(V7-V8) X 41/64
170	V4+(V3-V4) X 22/64	V8+(V7-V8) X 42/64
171	V4+(V3-V4) X 21/64	V8+(V7-V8) X 43/64
172	V4+(V3-V4) X 20/64	V8+(V7-V8) X 44/64
173	V4+(V3-V4) X 19/64	V8+(V7-V8) X 45/64
174	V4+(V3-V4) X 18/64	V8+(V7-V8) X 46/64
175	V4+(V3-V4) X 17/64	V8+(V7-V8) X 47/64
176	V4+(V3-V4) X 16/64	V8+(V7-V8) X 48/64
177	V4+(V3-V4) X 15/64	V8+(V7-V8) X 49/64
178	V4+(V3-V4) X 14/64	V8+(V7-V8) X 50/64
179	V4+(V3-V4) X 13/64	V8+(V7-V8) X 51/64
180	V4+(V3-V4) X 12/64	V8+(V7-V8) X 52/64
181	V4+(V3-V4) X 11/64	V8+(V7-V8) X 53/64
182	V4+(V3-V4) X 10/64	V8+(V7-V8) X 54/64
183	V4+(V3-V4) X 9/64	V8+(V7-V8) X 55/64
184	V4+(V3-V4) X 8/64	V8+(V7-V8) X 56/64
185	V4+(V3-V4) X 7/64	V8+(V7-V8) X 57/64
186	V4+(V3-V4) X 6/64	V8+(V7-V8) X 58/64
187	V4+(V3-V4) X 5/64	V8+(V7-V8) X 59/64
188	V4+(V3-V4) X 4/64	V8+(V7-V8) X 60/64
189	V4+(V3-V4) X 3/64	V8+(V7-V8) X 61/64
190	V4+(V3-V4) X 2/64	V8+(V7-V8) X 62/64
191	V4+(V3-V4) X 1/64	V8+(V7-V8) X 63/64

Output Voltage VS Input Data

Data(h)	Positive polarity Output Voltage	Negative polarity Output Voltage
192	V4	V7
193	V5+(V4V5) X 190/191	V7+(V6-V7) X 1/191
194	V5+(V4V5) X 189/191	V7+(V6-V7) X 2/191
195	V5+(V4V5) X 188/191	V7+(V6-V7) X 3/191
196	V5+(V4V5) X 187/191	V7+(V6-V7) X 4/191
197	V5+(V4V5) X 186/191	V7+(V6-V7) X 5/191
198	V5+(V4V5) X 185/191	V7+(V6-V7) X 6/191
199	V5+(V4V5) X 184/191	V7+(V6-V7) X 7/191
200	V5+(V4V5) X 183/191	V7+(V6-V7) X 8/191
201	V5+(V4V5) X 182/191	V7+(V6-V7) X 9/191
202	V5+(V4V5) X 181/191	V7+(V6-V7) X 10/191
203	V5+(V4V5) X 180/191	V7+(V6-V7) X 11/191
204	V5+(V4V5) X 179/191	V7+(V6-V7) X 12/191
205	V5+(V4V5) X 178/191	V7+(V6-V7) X 13/191
206	V5+(V4V5) X 177/191	V7+(V6-V7) X 14/191
207	V5+(V4V5) X 176/191	V7+(V6-V7) X 15/191
208	V5+(V4V5) X 175/191	V7+(V6-V7) X 16/191
209	V5+(V4V5) X 174/191	V7+(V6-V7) X 17/191
210	V5+(V4V5) X 173/191	V7+(V6-V7) X 18/191
211	V5+(V4V5) X 172/191	V7+(V6-V7) X 19/191
212	V5+(V4V5) X 171/191	V7+(V6-V7) X 20/191
213	V5+(V4V5) X 170/191	V7+(V6-V7) X 21/191
214	V5+(V4V5) X 169/191	V7+(V6-V7) X 22/191
215	V5+(V4V5) X 168/191	V7+(V6-V7) X 23/191
216	V5+(V4V5) X 167/191	V7+(V6-V7) X 24/191
217	V5+(V4V5) X 165/191	V7+(V6-V7) X 26/191
218	V5+(V4V5) X 163/191	V7+(V6-V7) X 28/191
219	V5+(V4V5) X 161/191	V7+(V6-V7) X 30/191
220	V5+(V4V5) X 159/191	V7+(V6-V7) X 32/191
221	V5+(V4V5) X 157/191	V7+(V6-V7) X 34/191
222	V5+(V4V5) X 155/191	V7+(V6-V7) X 36/191
223	V5+(V4V5) X 153/191	V7+(V6-V7) X 38/191
224	V5+(V4V5) X 151/191	V7+(V6-V7) X 40/191
225	V5+(V4V5) X 149/191	V7+(V6-V7) X 42/191
226	V5+(V4V5) X 147/191	V7+(V6-V7) X 44/191
227	V5+(V4V5) X 145/191	V7+(V6-V7) X 46/191
228	V5+(V4V5) X 143/191	V7+(V6-V7) X 48/191
229	V5+(V4V5) X 141/191	V7+(V6-V7) X 50/191
230	V5+(V4V5) X 139/191	V7+(V6-V7) X 52/191
231	V5+(V4V5) X 137/191	V7+(V6-V7) X 54/191
232	V5+(V4V5) X 135/191	V7+(V6-V7) X 56/191
233	V5+(V4V5) X 133/191	V7+(V6-V7) X 58/191
234	V5+(V4V5) X 131/191	V7+(V6-V7) X 60/191
235	V5+(V4V5) X 129/191	V7+(V6-V7) X 62/191
236	V5+(V4V5) X 127/191	V7+(V6-V7) X 64/191
237	V5+(V4V5) X 125/191	V7+(V6-V7) X 66/191
238	V5+(V4V5) X 122/191	V7+(V6-V7) X 69/191
239	V5+(V4V5) X 119/191	V7+(V6-V7) X 72/191
240	V5+(V4V5) X 116/191	V7+(V6-V7) X 75/191
241	V5+(V4V5) X 113/191	V7+(V6-V7) X 78/191
242	V5+(V4V5) X 110/191	V7+(V6-V7) X 81/191
243	V5+(V4V5) X 107/191	V7+(V6-V7) X 84/191
244	V5+(V4V5) X 104/191	V7+(V6-V7) X 87/191
245	V5+(V4V5) X 101/191	V7+(V6-V7) X 90/191
246	V5+(V4V5) X 97/191	V7+(V6-V7) X 94/191
247	V5+(V4V5) X 93/191	V7+(V6-V7) X 98/191
248	V5+(V4V5) X 89/191	V7+(V6-V7) X 102/191
249	V5+(V4V5) X 84/191	V7+(V6-V7) X 107/191
250	V5+(V4V5) X 79/191	V7+(V6-V7) X 112/191
251	V5+(V4V5) X 71/191	V7+(V6-V7) X 120/191
252	V5+(V4V5) X 61/191	V7+(V6-V7) X 130/191
253	V5+(V4V5) X 48/191	V7+(V6-V7) X 143/191
254	V5+(V4V5) X 29/191	V7+(V6-V7) X 162/191
255	V5	V6

Absolute Maximum Ratings*

***Comments**

Supply voltage, Vcc	-0.3V to 5V
Supply voltage, AVDD	-0.3V to +12V
Input voltage, V1~ V10	-0.3 to AVDD+0.3
Input range(digital inputs)	-0.3 to Vcc+0.3
Storage temperature	-55 to 110
Operating temperature	-30 to 75

Stresses above those listed under "Absolute Maximum Ratings" may cause permanent damage to the device. These are stress ratings only. Functional operation of this device at these or under any other conditions above those indicated in the operational sections of this specification are not implied and exposure to absolute maximum rating conditions for extended periods may affect device reliability.

DC Electrical Characteristics (Vcc=3.3V , AVDD=10V, AVSS=GND=0V, TA= -30 ~ 75)

(For the digital circuit)

Parameter	Symbol	Min.	Typ.	Max.	Unit	Conditions
Supply Voltage	Vcc	2.5	--	3.6	V	Digital power
Low Level Input Voltage	Vil	0	-	0.3xVcc	V	For the digital circuit
High Level Input Voltage	Vih	0.7xVcc	-	Vcc	V	For the digital circuit
High Level Output Voltage	Voh	0.7xVcc	-	--	V	DIO1(O), DIO2(O), loh=-0.4mA
Low Level Output Voltage	Vol	--	-	0.3Vcc	V	DIO1(O), DIO2(O), lol=0.4mA
Input Leakage Current	Ii	-1	-	1	μA	For LD,CLK,SHL,Dxx,POL,REV1/2,DIO1/2
Gamma correction Current	Iref	--	800	1000	μA	For V1-V5=4.75V or V6-V10=4.75V
Digital Operating Current	Icc	-	3	6	mA	Vcc=3.6V, AVDD=9.5V,fld=50kHz,fclk=45MHz No load

(For the analog circuit)

Parameter	Symbol	Min.	Typ.	Max.	Unit	Conditions
Supply Voltage	AVDD	7.0	--	10	V	For the analog circuit power
Input level of V1 ~ V5	Vref	AVDD/2	-	AVDD-0.1	V	Gamma correction voltage
Input level of V6 ~ V10	Vref	0.1	-	AVDD/2	V	Gamma correction voltage
Output Voltage Deviation	Vvd	--	±6	±12	mV	Input data ' without ' offset cancellation
		--	±2	±5	mV	Input data ' with ' offset cancellation (Note1)
Average output voltage dispersion	Vod	--	±5	±10	mV	OUT1 ~ OUT384,input data 00 to FF.
Dynamic Range of Output	Vdr	0.1	-	AVDD-0.1	V	OUT1 ~ OUT384
Low-Level Output Current	IOL	-150	-300	-	μA	OUT1 ~ OUT384; Vo=0.1V V.S 1.0V
High-Level Output Current	IOH	150	300	-	μA	OUT1 ~ OUT384; Vo=9.9V V.S 9V
Analog Operating Current	IDD	-	6	12	mA	Vcc=3.6V,AVDD=9.5V,fld=50kHz,fclk=45MHz No load
Input capacitance1	C1	--	5	10	pF	For Input pins ,except DIO1,DIO2
Input capacitance2	C2	--	10	15	pF	For DIO1,DIO2

(Note 1) This chip needs 253 CLK cycles to use its 'offset cancellation' function to get a precision output voltage.
Please refer to the timing chart below :

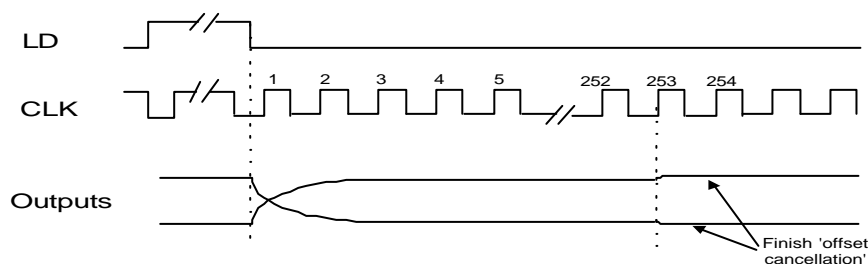

AC Electrical Characteristics 1 ($V_{CC}=3.0V$, $AV_{DD}=10V$, $AV_{SS}=GND=0V$, $T_A=-30 \sim 75$, $T_r=T_f=2ns$)

Parameter	Symbol	Min.	Typ.	Max.	Unit	Conditions
CLK frequency	Fclk	-	45	70	MHz	$V_{CC}=3.0\sim 3.6V$
CLK period cycle	Tcph	14	-	-	ns	
CLK pulse width	Icw	4	-	-	ns	
Data set-up time	I _{su}	2	-	-	ns	D00 ~ D57, REV to CLK
Data hold time	I _{hd}	2	-	-	ns	D00 ~ D57, REV to CLK
Start pulse setup time	I _{ss}	2	--	--	ns	DIO1, DIO2 to CLK
Start pulse hold time	I _{sh}	2	--	--	ns	DIO1, DIO2 to CLK
LD high-level width	I _{ld}	1	--	--	us	
Propagation delay of DIO2/1	I _{plh}	6	--	12	ns	CL=25pF (Output)
Time that the last data to LD	I _{ldt}	1	-	-	Tcph	
Time that LD to DIO1/2(In)	I _{lds}	2	-	-	Tcph	
POL set-up time	I _{psu}	5	-	-	ns	POL to LD
POL hold time	I _{phd}	5	-	-	ns	POL to LD
Output stable time	I _{st}	-	4	6	us	Final value precision below 30mV, CL=150pF, R=5k ohm, AV _{DD} =10V
Slew rate of outputs	I _{sr}	3	5	-	V/us	5% to 95% at 10V swing, CL=150pF, R=5k ohm
Output loading	CL	-	-	150	pF	

AC Electrical Characteristics 2 ($V_{CC}=2.5V$, $AV_{DD}=10V$, $AV_{SS}=GND=0V$, $T_A=-30\sim 75$, $T_r=T_f=3ns$)

Parameter	Symbol	Min.	Typ.	Max.	Unit	Conditions
CLK frequency	Fclk	-	35	45	MHz	$V_{CC}=2.5\sim 3.0V$
CLK period cycle	Tcph	22	-	-	ns	
CLK pulse width	Icw	7	-	-	ns	
Data set-up time	I _{su}	4	-	-	ns	D00 ~ D57, REV to CLK
Data hold time	I _{hd}	4	-	-	ns	D00 ~ D57, REV to CLK
Start pulse setup time	I _{ss}	4	--	--	ns	DIO1, DIO2 to CLK
Start pulse hold time	I _{sh}	4	--	--	ns	DIO1, DIO2 to CLK
LD high-level width	I _{ld}	1	--	--	us	
Propagation delay of DIO2/1	I _{plh}	6	--	18	ns	CL=25pF (Output)
Time that the last data to LD	I _{ldt}	1	-	-	Tcph	
Time that LD to DIO1/2(In)	I _{lds}	2	-	-	Tcph	
POL set-up time	I _{psu}	5	-	-	ns	POL to LD
POL hold time	I _{phd}	5	-	-	ns	POL to LD
Output stable time	I _{st}	-	4	6	us	Final value precision below 30mV, CL=150pF, R=5k ohm, AV _{DD} =10V
Slew rate of outputs	I _{sr}	3	5	-	V/us	5% to 95% at 10V swing, CL=150pF, R=5k ohm
Output loading	CL	-	-	150	pF	

Timing Diagram

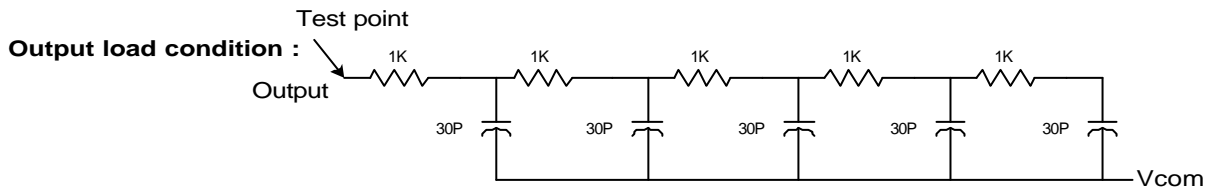
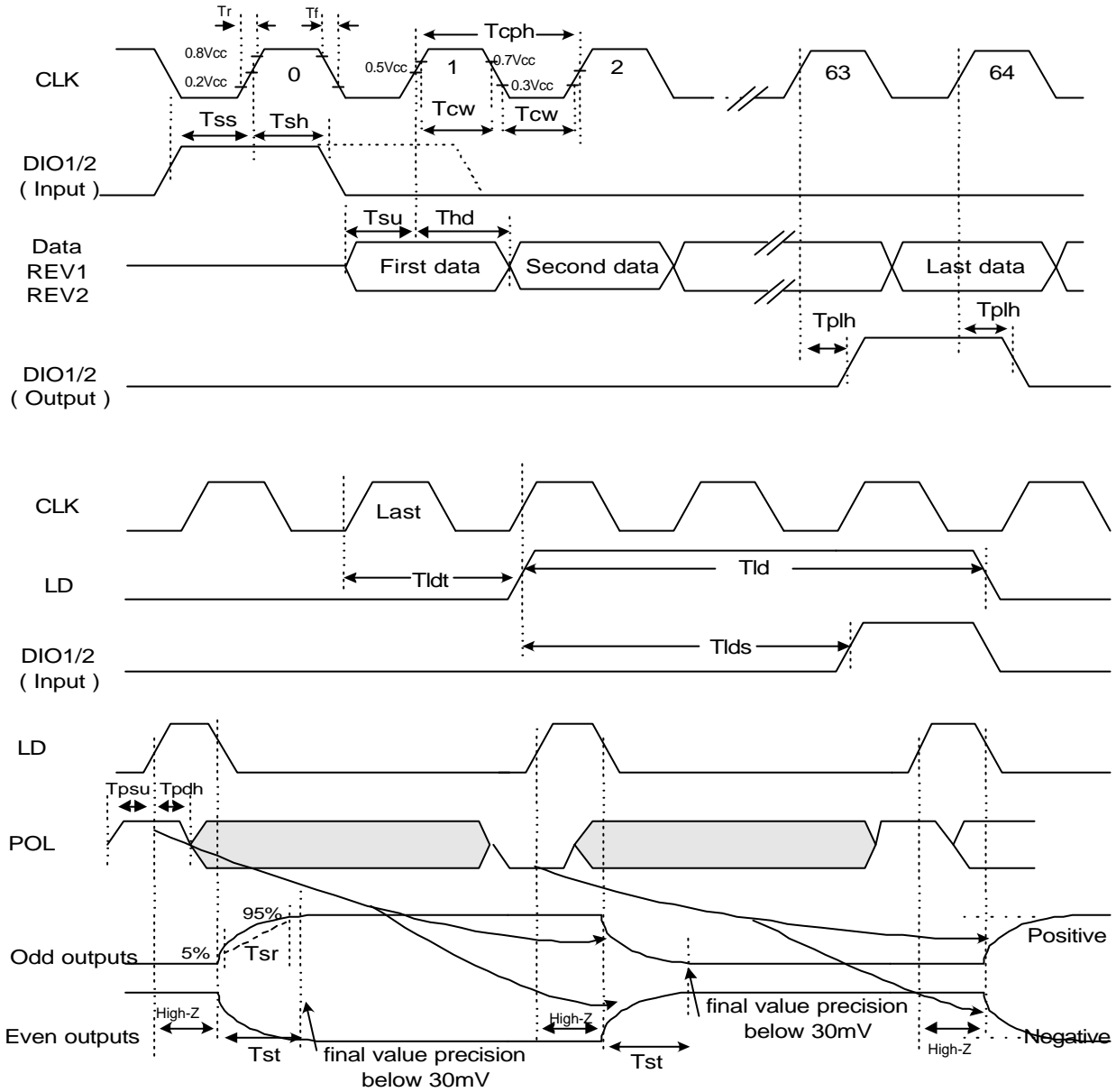

Function operation

