

NTE923 & NTE923D Integrated Circuit Precision Voltage Regulator

Description:

The NTE923 and NTE923D are voltage regulators designed primarily for series regulator applications. By themselves, these devices will supply output currents up to 150mA; but, external transistors can be added to provide any desired load current. The circuits feature extremely low standby current drain, and provision is made for either linear or foldback current limiting.

These devices are also useful in a wide range of other applications such as shunt regulators, current regulators, and temperature controllers.

Features:

- 150mA Output Current without External Pass Transistor
- Output Currents in Excess of 10A Possible by Adding External Transistors
- Input Voltage: 40V Max
- Output Voltage Adjustable from 2V to 37V
- Can be Used as Either a Linear or a Switching Regulator

Absolute Maximum Ratings:

Pulse Voltage from V+ to V- (50ms)	50V
Continuous Voltage from V+ to V-	40V
Input-Output Voltage Differential	40V
Maximum Amplifier Input Voltage	
Either Input	8.5V
Differential	5.0V
Current from V _Z	25mA
Current from V _{REF}	15mA
Internal Power Dissipation	
NTE923	800mW
NTE923D	660mW
Operating Temperature Range	0° to +70°C
Storage Temperature Range	
NTE923	-65° to +150°C
NTE923D	-55° to +150°C
Lead Temperature (During Soldering, 4sec max)	
NTE923	+300°C
NTE923D	+260°C

Electrical Characteristics: (Note 1)

Parameter	Test Conditions	Min	Typ	Max	Unit	
Line Regulation	$V_{IN} = 12V$ to $15V$	–	0.01	0.1	% V_{OUT}	
		–	–	0.3	% V_{OUT}	
	$V_{IN} = 12V$ to $40V$	–	0.1	0.5	% V_{OUT}	
Load Regulation	$I_L = 1mA$ to $50mA$	–	0.03	0.2	% V_{OUT}	
		–	–	0.6	% V_{OUT}	
Ripple Rejection	$f = 50Hz$ to $10kHz$	$C_{REF} = 0$	–	74	–	dB
		$C_{REF} = 5\mu F$	–	86	–	dB
Average Temperature Coefficient of Output Voltage	$0^\circ \leq T_A \leq +70^\circ C$, Note 2	–	0.003	0.015	%/ $^\circ C$	
Short Circuit Current Limit	$R_{SC} = 10\Omega$, $V_{OUT} = 0$	–	65	–	mA	
Reference Voltage		6.80	7.15	7.50	V	
Output Noise Voltage	BW = 100Hz to 10kHz	$C_{REF} = 0$	–	86	–	μV_{rms}
		$C_{REF} = 5\mu F$	–	2.5	–	μV_{rms}
Long Term Stability		–	0.05	–	%/1000Hrs	
Standby Current Drain	$I_L = 0$, $V_{IN} = 30V$	–	1.7	4.0	mA	
Input Voltage Range		9.5	–	40	V	
Output Voltage Range		2.0	–	37	V	
Input–Output Voltage Differential		3.0	–	38	V	
Thermal Resistance, Junction to Ambient	NTE923D	–	105	–	$^\circ C/W$	
	NTE923	Board mount in still air	–	225	–	$^\circ C/W$
		Board mount in 400LF/Min Air flow	–	90	–	$^\circ C/W$
Thermal Resistance, Junction to Case		–	25	–	$^\circ C/W$	

Note 1. Unless otherwise otherwise specified, $T_A = +25^\circ C$, $V_{IN} = V_+ = V_C = 12V$, $V_- = 0$, $V_{OUT} = 5V$, $I_L = 1mA$, $R_{SC} = 0$, $C_i = 100pF$, $C_{REF} = 0$ and divider impedance as seen by error amplifier $\leq 10k\Omega$. Line and load regulation specifications are given for the condition of constant chip temperature. Temperature drifts must be taken into account separately for high dissipation conditions.

Note 2. Guaranteed by correlation to other tests.

Note 3. For metal can applications where V_Z is required, an external 6.2V zener diode should be connected in series with V_{OUT} .

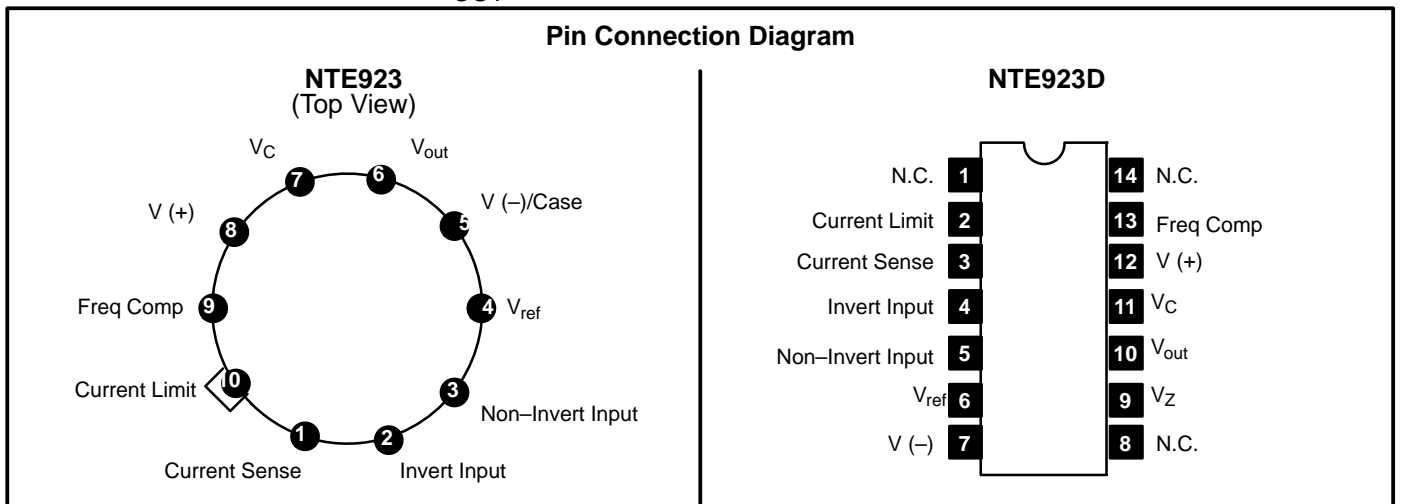

NTE923

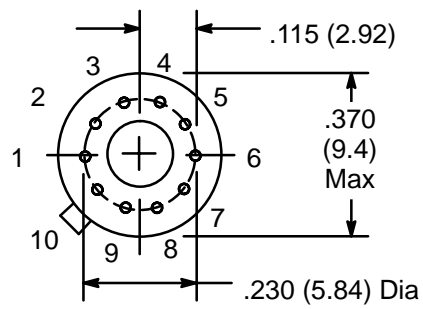
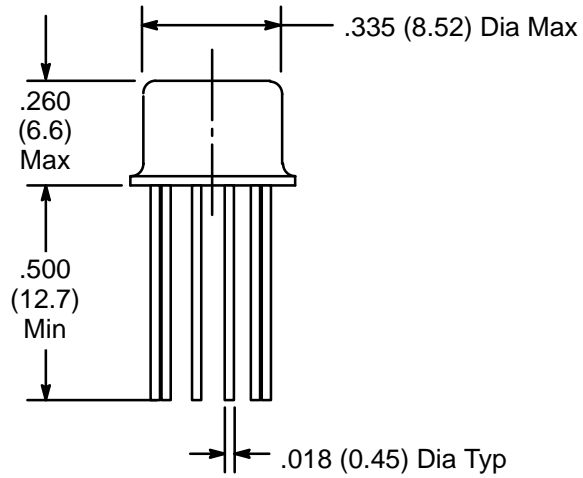

NTE923D

