

## FEATURES

- Low input offset voltage: 75  $\mu\text{V}$  maximum**
- Low offset voltage drift, over  $-55^\circ\text{C} < T_A < +125^\circ\text{C}$**   
**0.5  $\mu\text{V}/^\circ\text{C}$  maximum**
- Low supply current (per amplifier): 725  $\mu\text{A}$  maximum**
- High open-loop gain: 5000 V/mV minimum**
- Low input bias current: 2 nA maximum**
- Low noise voltage density: 11 nV/ $\sqrt{\text{Hz}}$  at 1 kHz**
- Stable with large capacitive loads: 10 nF typical**

## PIN CONNECTIONS

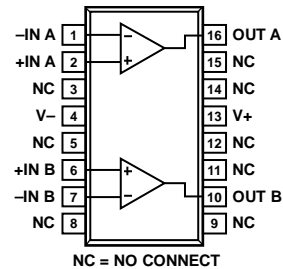

Figure 1. 16-Lead SOIC (S-Suffix)

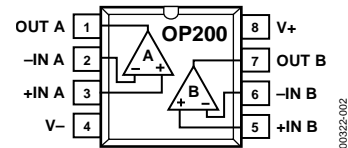

Figure 2. 8-Lead PDIP (P-Suffix)  
8-Lead CERDIP (Z-Suffix)

## GENERAL DESCRIPTION

The OP200 is the first monolithic dual operational amplifier to offer OP77 type precision performance. Available in the industry standard 8-lead pinout, the OP200 combines precision performance with the space and cost savings offered by a dual amplifier.

The OP200 features an extremely low input offset voltage of less than 75  $\mu\text{V}$  with a drift below 0.5  $\mu\text{V}/^\circ\text{C}$ , guaranteed over the full military temperature range. Open-loop gain of the OP200 exceeds 5,000,000 into a 10 k $\Omega$  load; input bias current is under 2 nA; CMRR is over 120 dB; and PSRR is below 1.8  $\mu\text{V}/\text{V}$ . On-chip Zener zap trimming is used to achieve the extremely low input offset voltage of the OP200 and eliminates the need for offset pulling.

Power consumption of the OP200 is low, with each amplifier drawing less than 725  $\mu\text{A}$  of supply current. The total current drawn by the dual OP200 is less than one-half that of a single OP07, yet the OP200 offers significant improvements over this industry-standard op amp. The voltage noise density of the OP200, 11 nV/ $\sqrt{\text{Hz}}$  at 1 kHz, is half that of most competitive devices.

The OP200 is pin compatible with the OP221, LM158, MC1458/MC1558, and LT1013.

The OP200 is an ideal choice for applications requiring multiple precision op amps and where low power consumption is critical.

For a quad precision op amp, see the OP400.

**TABLE OF CONTENTS**

Features ..... 1  
 Pin Connections ..... 1  
 General Description ..... 1  
 Revision History ..... 2  
 Specifications..... 4  
     Electrical Characteristics ..... 4  
 Absolute Maximum Ratings..... 7  
     Thermal Resistance ..... 7  
     ESD Caution..... 7  
 Typical Performance Characteristics ..... 8

Applications Information ..... 12  
     Dual Low Power Instrumentation Amplifier ..... 12  
     Precision Absolute Value Amplifier..... 12  
     Precision Current Pump..... 12  
     Dual 12-Bit Voltage Output DAC ..... 13  
     Dual Precision Voltage Reference ..... 13  
     Programmable High Resolution Window Comparator ..... 14  
 Outline Dimensions ..... 15  
 Ordering Guide ..... 16

**REVISION HISTORY**

**9/12—Rev. D to Rev. E**

Changed Table 2 Conditions from  $V_S = 15\text{ V}$  to  $V_S = \pm 15\text{ V}$ ..... 4  
 Updated Outline Dimensions ..... 15  
 Changes to Ordering Guide ..... 16

**2/09—Rev. C to Rev. D**

Change to Large Signal Voltage Gain, Table 2 ..... 4  
 Changes to Ordering Guide ..... 16

**8/08—Rev. B to Rev. C**

Updated Format..... Universal  
 Changes to Features Section..... 1  
 Changes to Table 1 and Table 2..... 4  
 Changes to Table 3 and Table 4..... 5  
 Deleted Table 7; Renumbered Sequentially..... 5  
 Changes to Figure 15..... 9  
 Changes to Figure 21..... 10  
 Changes to Figure 30 and Figure 31..... 12  
 Changes to Programmable High Resolution Window  
 Comparator Section, Figure 33, and Figure 34..... 13  
 Changes to Figure 35..... 14  
 Updated Outline Dimensions ..... 15  
 Changes to Ordering Guide ..... 16

**2/04—Data Sheet changed from Rev. A to Rev. B.**

OP200F Deleted..... Universal  
 Changes to Ordering Guide .....5  
 Changes to Figure 4.....8  
 Updated Outline Dimension ..... 11

**4/02—Data Sheet changed from Rev. 0 to Rev. A.**

Edits to Features.....1  
 Edits to General Description .....1  
 Edits to Ordering Information .....1  
 Edits to Pin Connections.....1  
 Edits to Absolute Maximum Ratings .....2  
 Edits to Package Type .....2

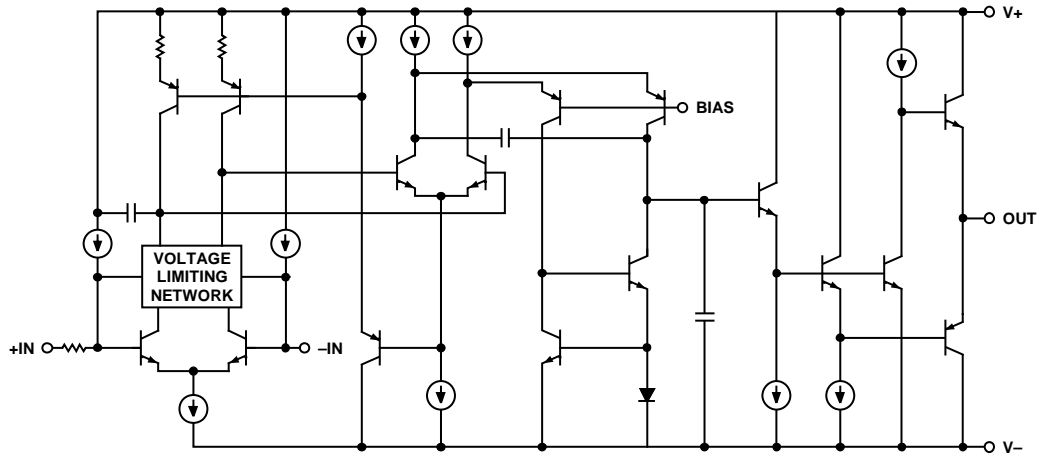

Figure 3. Simplified Schematic (One of Two Amplifiers Shown)

0322-003

## SPECIFICATIONS

## ELECTRICAL CHARACTERISTICS

$V_S = \pm 15\text{ V}$ ,  $T_A = 25^\circ\text{C}$ , unless otherwise noted.

Table 1.

Parameter	Symbol	Conditions	OP200A/E			OP200G			Unit
			Min	Typ	Max	Min	Typ	Max	
INPUT CHARACTERISTICS									
Input Offset Voltage	$V_{OS}$			25	75		80	200	$\mu\text{V}$
Long-Term Input Voltage Stability				0.1			0.1		$\mu\text{V}/\text{mo}$
Input Offset Current	$I_{OS}$	$V_{CM} = 0\text{ V}$		0.05	1.0		0.05	3.5	nA
Input Bias Current	$I_B$	$V_{CM} = 0\text{ V}$		0.1	2.0		0.1	5.0	nA
Input Noise Voltage	$e_n$ p-p	0.1 Hz to 10 Hz		0.5			0.5		$\mu\text{V}$ p-p
Input Noise Voltage Density <sup>1</sup>	$e_n$	$f_o = 10\text{ Hz}$		22	36		22		$\text{nV}/\sqrt{\text{Hz}}$
		$f_o = 1000\text{ Hz}$		11	18		11		$\text{nV}/\sqrt{\text{Hz}}$
Input Noise Current	$i_n$ p-p	0.1 Hz to 10 Hz		15			15		$\text{pA}$ p-p
Input Noise Current Density	$i_n$	$f_o = 10\text{ Hz}$		0.4			0.4		$\text{pA}/\sqrt{\text{Hz}}$
Input Resistance Differential Mode	$R_{IN}$			10			10		$\text{M}\Omega$
Input Resistance Common Mode	$R_{INCM}$			125			125		$\text{G}\Omega$
Large Signal Voltage Gain	$A_{VO}$	$V_O = \pm 10\text{ V}$							
		$R_L = 10\text{ k}\Omega$	5000	12000		3000	7000		$\text{M}/\text{mV}$
		$R_L = 2\text{ k}\Omega$	2000	3700		1500	3200		$\text{M}/\text{mV}$

<sup>1</sup> Sample tested.

$V_S = \pm 15\text{ V}$ ,  $-55^\circ\text{C} \leq T_A \leq +125^\circ\text{C}$  for OP200A, unless otherwise noted.

Table 2.

Parameter	Symbol	Conditions	OP200A			Unit
			Min	Typ	Max	
INPUT CHARACTERISTICS						
Input Offset Voltage	$V_{OS}$			45	125	$\mu\text{V}$
Average Input Offset Voltage Drift	$\text{TCV}_{OS}$			0.2	0.5	$\mu\text{V}/^\circ\text{C}$
Input Offset Current	$I_{OS}$	$V_{CM} = 0\text{ V}$		0.15	2.5	nA
Input Bias Current	$I_B$	$V_{CM} = 0\text{ V}$		0.9	5.0	nA
Large Signal Voltage Gain	$A_{VO}$	$V_O = 10\text{ V}$				
		$R_L = 10\text{ k}\Omega$	3000	9000		$\text{V}/\text{mV}$
		$R_L = 2\text{ k}\Omega$	1000	2700		$\text{V}/\text{mV}$
Input Voltage Range <sup>1</sup>	IVR		$\pm 12$	$\pm 12.5$		V
Common-Mode Rejection Ratio	CMRR	$V_{CM} = \pm 12\text{ V}$	115	130		dB
Capacitive Load Stability		$A_V = 1$		8		nF
POWER SUPPLY						
Power Supply Rejection Ratio	PSRR	$V_S = 3\text{ V to } 18\text{ V}$		0.2	3.2	$\mu\text{V}/\text{V}$
Supply Current Per Amplifier	$I_{SY}$	No load		600	775	$\mu\text{A}$
OUTPUT CHARACTERISTICS						
Output Voltage Swing	$V_O$	$R_L = 10\text{ k}\Omega$	$\pm 12$	$\pm 12.4$		V
		$R_L = 2\text{ k}\Omega$	$\pm 11$	$\pm 12$		V

<sup>1</sup> Guaranteed by CMRR test.

$V_S = \pm 15\text{ V}$ ,  $T_A = 25^\circ\text{C}$ , unless otherwise noted.

Table 3.

Parameter	Symbol	Conditions	OP200A/E			OP200G			Unit
			Min	Typ	Max	Min	Typ	Max	
INPUT CHARACTERISTICS									
Input Voltage Range <sup>1</sup>	IVR		$\pm 12$	$\pm 13$		$\pm 12$	$\pm 13$		V
Common-Mode Rejection Ratio	CMRR	$V_{CM} = \pm 12\text{ V}$	120	135		110	130		dB
Channel Separation <sup>2</sup>	CS	$V_O = 20\text{ V p-p}$ , $f_O = 10\text{ Hz}$	123	145		123	145		dB
Input Capacitance	$C_{IN}$			3.2			3.2		pF
Capacitive Load Stability		$A_V = 1$ , no oscillations		10			10		nF
POWER SUPPLY									
Power Supply Rejection Ratio	PSRR	$V_S = \pm 3\text{ V to } \pm 18\text{ V}$		0.4	1.8		0.6	5.6	$\mu\text{V/V}$
Supply Current Per Amplifier	$I_{SY}$	No load		570	725		570	725	$\mu\text{A}$
OUTPUT CHARACTERISTICS									
Output Voltage Swing	$V_O$	$R_L = 10\text{ k}\Omega$	$\pm 12$	$\pm 12.6$		$\pm 12$	$\pm 12.6$		V
		$R_L = 2\text{ k}\Omega$	$\pm 11$	$\pm 12.2$		$\pm 11$	$\pm 12.2$		V
DYNAMIC PERFORMANCE									
Slew Rate	SR		0.1	0.15		0.1	0.15		$\text{V}/\mu\text{s}$
Gain Bandwidth Product	GBP	$A_V = 1$		500			500		kHz

<sup>1</sup> Guaranteed by CMRR test.

<sup>2</sup> Guaranteed but not 100% tested.

$V_S = \pm 15\text{ V}$ ,  $-40^\circ\text{C} \leq T_A \leq +85^\circ\text{C}$ , unless otherwise noted.

Table 4.

Parameter	Symbol	Conditions	OP200E			OP200G			Unit
			Min	Typ	Max	Min	Typ	Max	
INPUT CHARACTERISTICS									
Input Offset Voltage	$V_{OS}$			35	100		110	300	$\mu\text{V}$
Average Input Offset Voltage Drift	$TCV_{OS}$			0.2	0.5		0.6	2.0	$\mu\text{V}/^\circ\text{C}$
Input Offset Current	$I_{OS}$	$V_{CM} = 0\text{ V}$		0.08	2.5		0.1	6.0	nA
Input Bias Current	$I_B$	$V_{CM} = 0\text{ V}$		0.3	5.0		0.5	10.0	nA
Large-Signal Voltage Gain	$A_{VO}$	$V_O = \pm 10\text{ V}$							
		$R_L = 10\text{ k}\Omega$	3000	10,000		2000	5000		$\text{V}/\text{mV}$
		$R_L = 2\text{ k}\Omega$	1500	3200		1000	2500		$\text{V}/\text{mV}$
Input Voltage Range <sup>1</sup>	IVR		$\pm 12$	$\pm 12.5$		$\pm 12$	$\pm 12.5$		V
Common-Mode Rejection Ratio	CMRR	$V_{CM} = \pm 12\text{ V}$	115	130		105	130		dB
Capacitive Load Stability		$A_V = 1$ , no oscillations		10			10		nF
POWER SUPPLY									
Power Supply Rejection Ratio	PSRR	$V_S = \pm 3\text{ V to } \pm 18\text{ V}$		0.15	3.2		0.3	10.0	$\mu\text{V/V}$
Supply Current Per Amplifier	$I_{SY}$	No load		600	775		600	775	$\mu\text{A}$
OUTPUT CHARACTERISTICS									
Output Voltage Swing	$V_O$	$R_L = 10\text{ k}\Omega$	$\pm 12$	$\pm 12.4$		$\pm 12$	$\pm 12.4$		V
		$R_L = 2\text{ k}\Omega$	$\pm 11$	$\pm 12$		$\pm 11$	$\pm 12.2$		V

<sup>1</sup> Guaranteed by CMRR test.

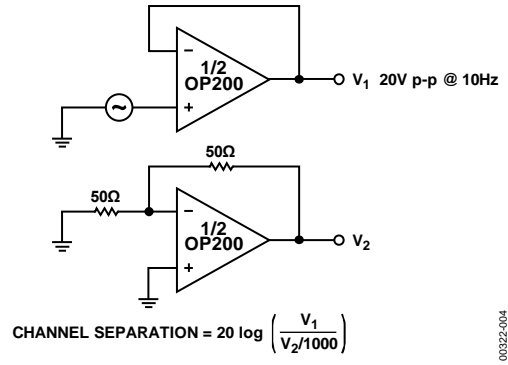

00322-004

Figure 4. Channel Separation Test Circuit

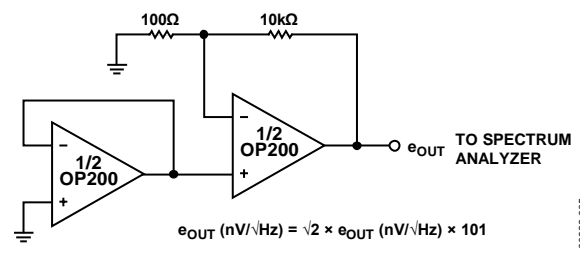

00322-005

Figure 5. Noise Test Schematic

## ABSOLUTE MAXIMUM RATINGS

Table 5.

Parameter	Rating
Supply Voltage	$\pm 20$ V
Differential Input Voltage	$\pm 30$ V
Input Voltage	Supply voltage
Output Short-Circuit Duration	Continuous
Storage Temperature Range	$-65^{\circ}\text{C}$ to $+150^{\circ}\text{C}$
Lead Temperature (Soldering, 60 sec)	$300^{\circ}\text{C}$
Junction Temperature Range ( $T_J$ )	$-65^{\circ}\text{C}$ to $+150^{\circ}\text{C}$
Operating Temperature Range	
OP200A	$-55^{\circ}\text{C}$ to $+125^{\circ}\text{C}$
OP200E, OP200G	$-40^{\circ}\text{C}$ to $+85^{\circ}\text{C}$

Stresses above those listed under Absolute Maximum Ratings may cause permanent damage to the device. This is a stress rating only; functional operation of the device at these or any other conditions above those indicated in the operational section of this specification is not implied. Exposure to absolute maximum rating conditions for extended periods may affect device reliability.

## THERMAL RESISTANCE

Table 6.

Package Type	$\theta_{JA}^1$	$\theta_{JC}$	Unit
8-Lead CERDIP (Z Suffix)	148	16	$^{\circ}\text{C}/\text{W}$
8-Lead Plastic DIP (P Suffix)	96	37	$^{\circ}\text{C}/\text{W}$
16-Lead SOIC (S Suffix)	92	27	$^{\circ}\text{C}/\text{W}$

<sup>1</sup>  $\theta_{JA}$  is specified for worst-case mounting conditions, that is,  $\theta_{JA}$  is specified for device in socket for CERDIP and PDIP packages;  $\theta_{JA}$  is specified for device soldered to printed circuit board for SOIC package.

## ESD CAUTION



**ESD (electrostatic discharge) sensitive device.** Charged devices and circuit boards can discharge without detection. Although this product features patented or proprietary protection circuitry, damage may occur on devices subjected to high energy ESD. Therefore, proper ESD precautions should be taken to avoid performance degradation or loss of functionality.

TYPICAL PERFORMANCE CHARACTERISTICS

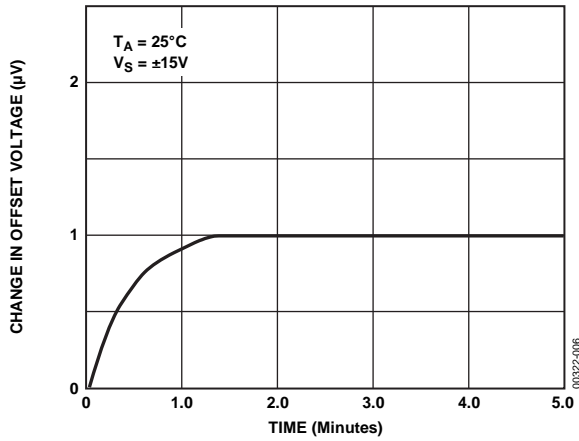

Figure 6. Warm-Up Drift

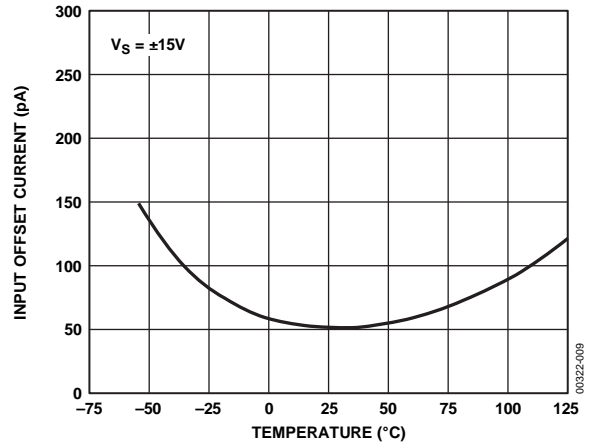

Figure 9. Input Offset Current vs. Temperature

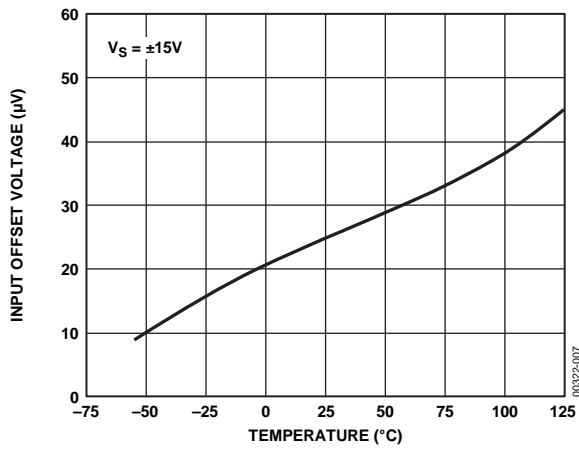

Figure 7. Input Offset Voltage vs. Temperature

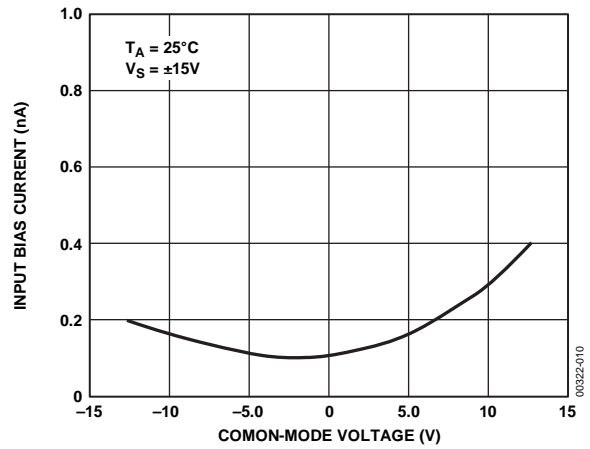

Figure 10. Input Bias Current vs. Common-Mode Voltage

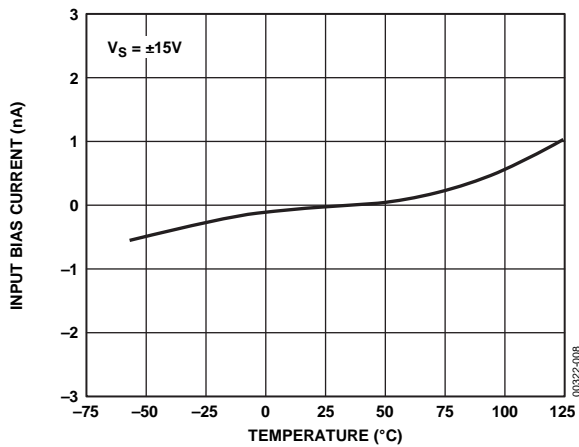

Figure 8. Input Bias Current vs. Temperature

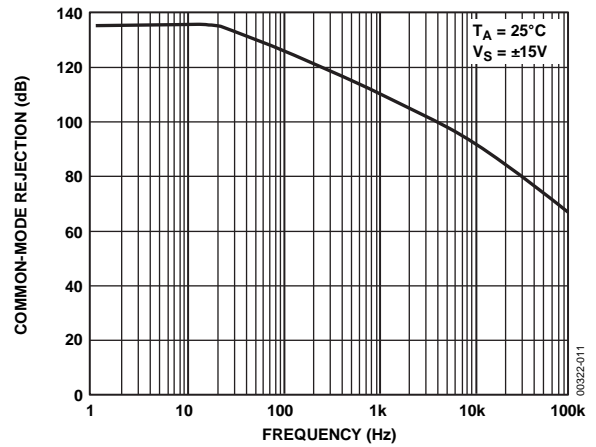

Figure 11. Common-Mode Rejection vs. Frequency



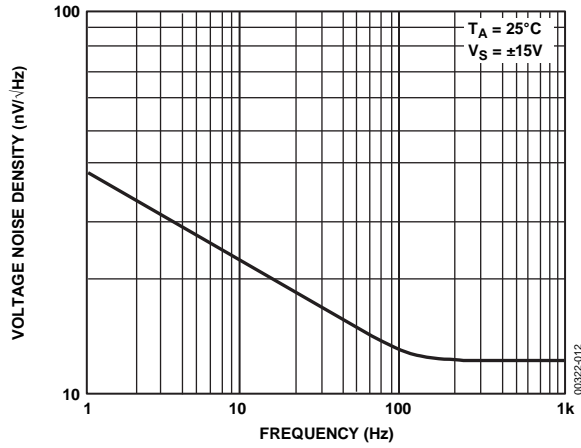

Figure 12. Voltage Noise Density vs. Frequency

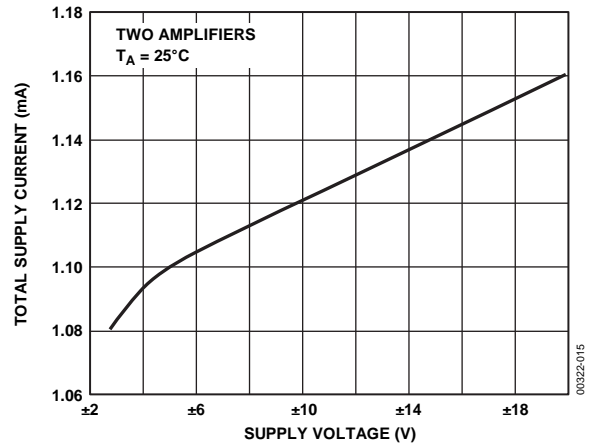

Figure 15. Total Supply Current vs. Supply Voltage

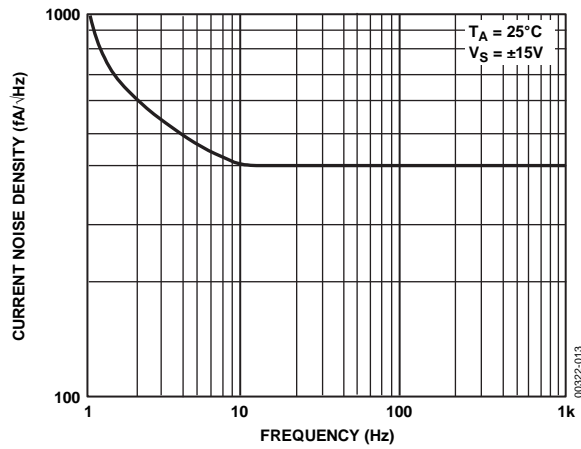

Figure 13. Current Noise Density vs. Frequency

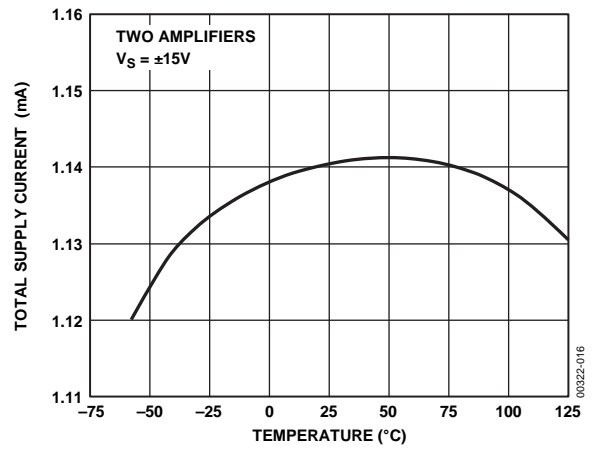

Figure 16. Total Supply Current vs. Temperature

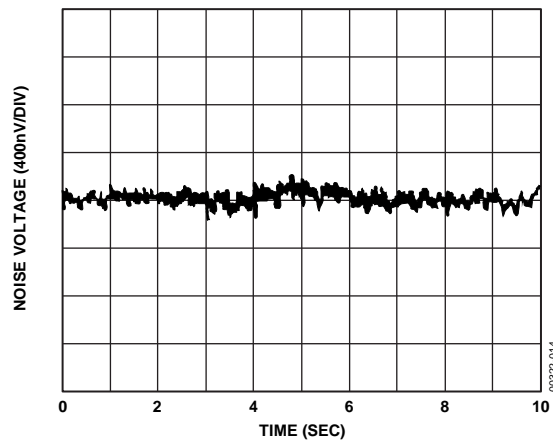

Figure 14. 0.1 Hz to 10 Hz Noise

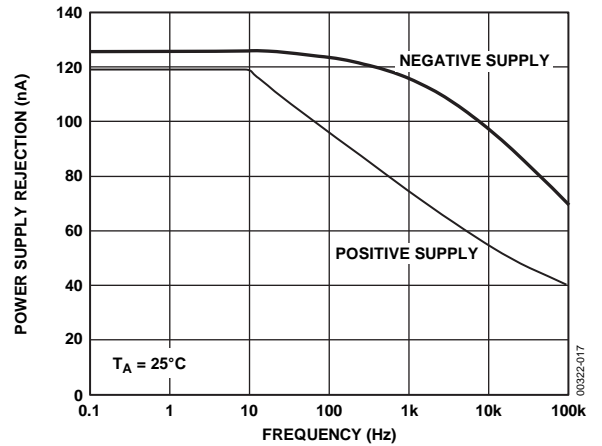

Figure 17. Power Supply Rejection vs. Frequency

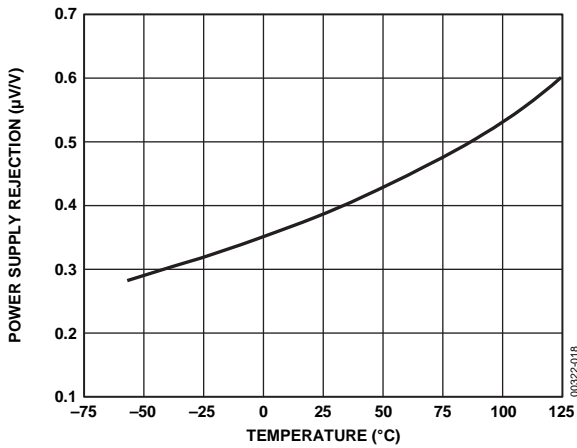

Figure 18. Power Supply Rejection vs. Temperature

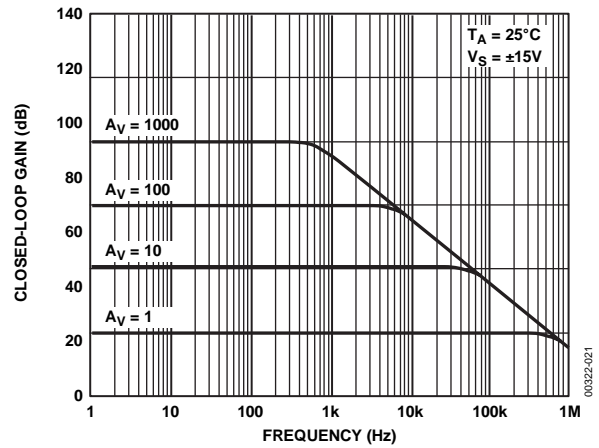

Figure 21. Closed-Loop Gain vs. Frequency

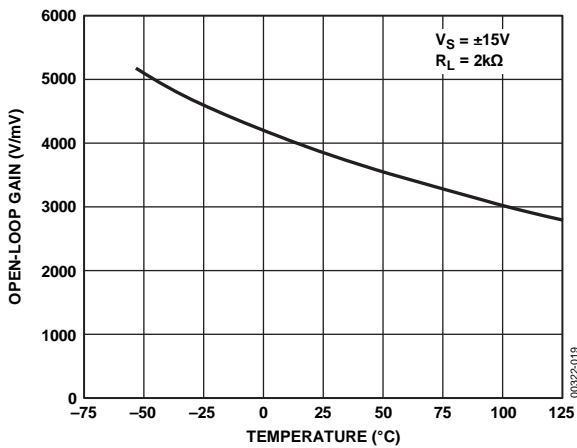

Figure 19. Open-Loop Gain vs. Temperature

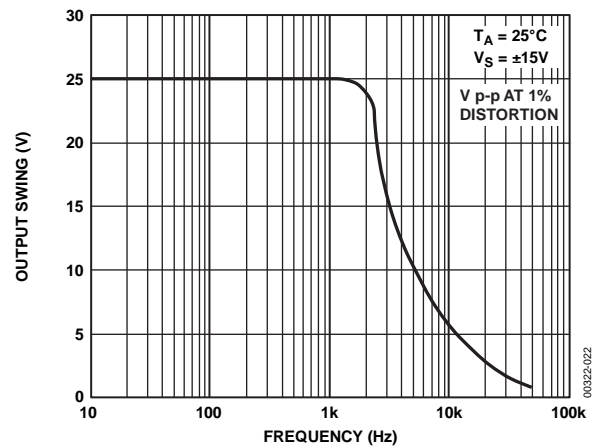

Figure 22. Maximum Output Swing vs. Frequency

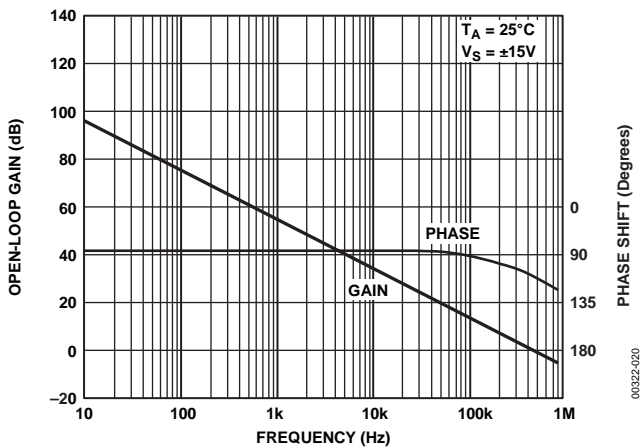

Figure 20. Open-Loop Gain and Phase Shift vs. Frequency

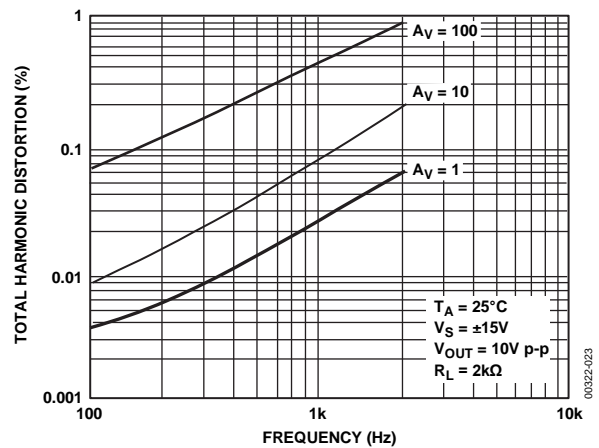

Figure 23. Total Harmonic Distortion vs. Frequency

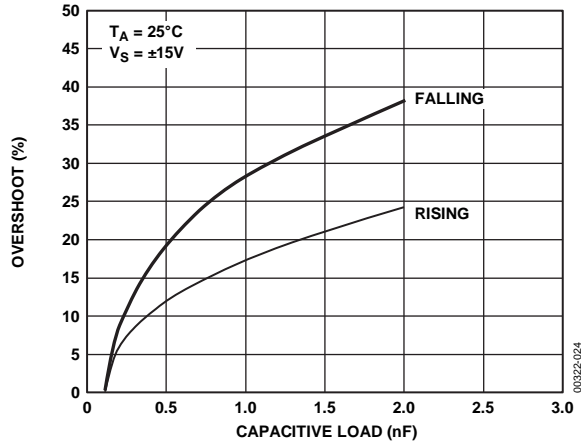

Figure 24. Overshoot vs. Capacitive Load

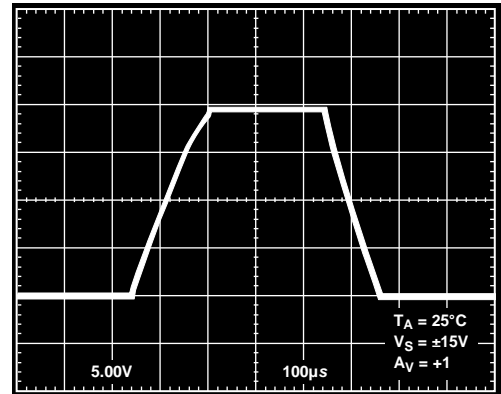

Figure 27. Large Signal Transient Response

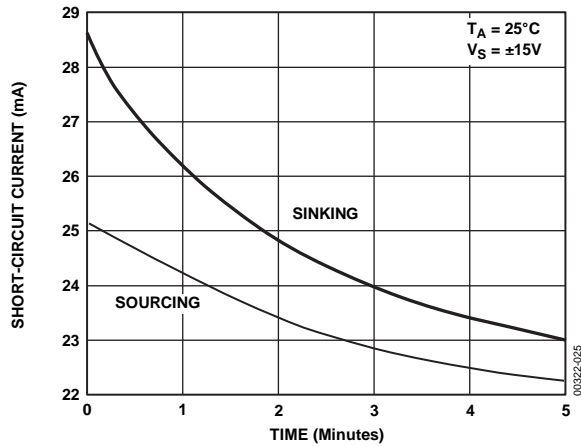

Figure 25. Short-Circuit Current vs. Time

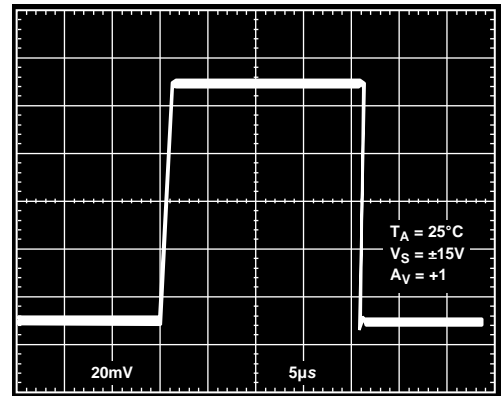

Figure 28. Small Signal Transient Response

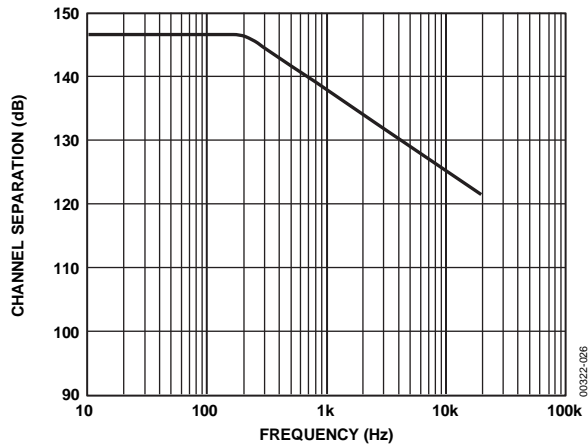

Figure 26. Channel Separation vs. Frequency

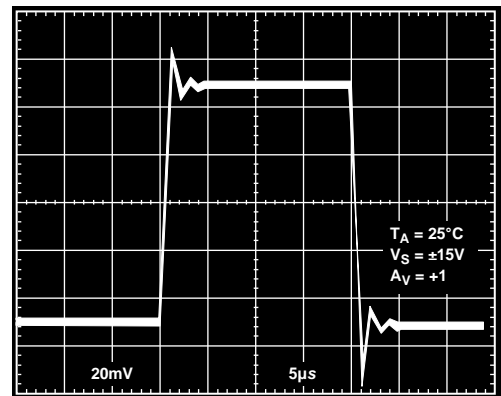

Figure 29. Small Signal Transient Response,  $C_{LOAD} = 1\text{ nF}$

### APPLICATIONS INFORMATION

The OP200 is inherently stable at all gains and is capable of driving large capacitive loads without oscillating. Nonetheless, good supply decoupling is highly recommended. Proper supply decoupling reduces problems caused by supply line noise and improves the capacitive load driving capability of the OP200.

### DUAL LOW POWER INSTRUMENTATION AMPLIFIER

A dual instrumentation amplifier that consumes less than 33 mW of power per channel is shown in Figure 30. The linearity of the instrumentation amplifier exceeds 16 bits in gains of 5 to 200 and is better than 14 bits in gains from 200 to 1000. CMRR is above 115 dB (gain = 1000). Offset voltage drift is typically 0.2  $\mu\text{V}/^\circ\text{C}$  over the military temperature range, which is comparable to the best monolithic instrumentation amplifiers. The bandwidth of the low power instrumentation amplifier is a function of gain and is shown in Table 7.

Table 7. Gain Bandwidth

Gain	Bandwidth
5	150 kHz
10	67 kHz
100	7.5 kHz
1000	500 Hz

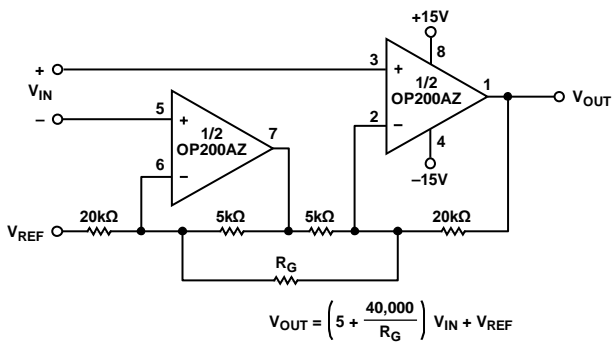

Figure 30. Dual Low Power Instrumentation Amplifier

The output signal is specified with respect to the reference input, which is normally connected to analog ground. The reference input can be used to offset the output from -10 V to +10 V if required.

### PRECISION ABSOLUTE VALUE AMPLIFIER

The circuit in Figure 31 is a precision absolute value amplifier with an input impedance of 10 M $\Omega$ . The high gain and low TCV<sub>OS</sub> of the OP200 ensure accurate operation with microvolt input signals. In this circuit, the input always appears as a common-mode signal to the op amps. The CMRR of the OP200 exceeds 120 dB, yielding an error of less than 2 ppm.

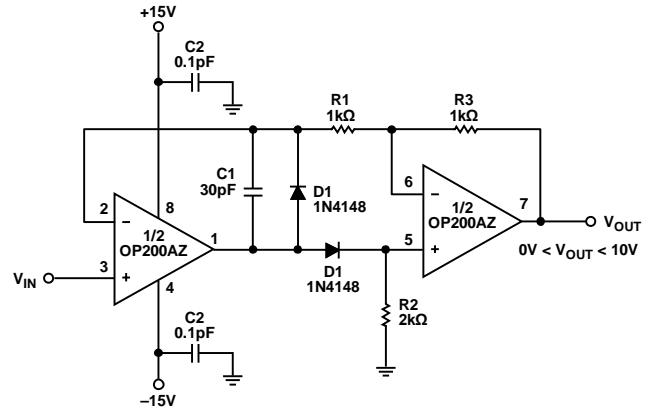

Figure 31. Precision Absolute Value Amplifier

### PRECISION CURRENT PUMP

The maximum output current of the precision current pump shown in Figure 32 is  $\pm 10$  mA. Voltage compliance is  $\pm 10$  V with  $\pm 15$  V supplies. Output impedance of the current transmitter exceeds 3 M $\Omega$  with linearity better than 16 bits.

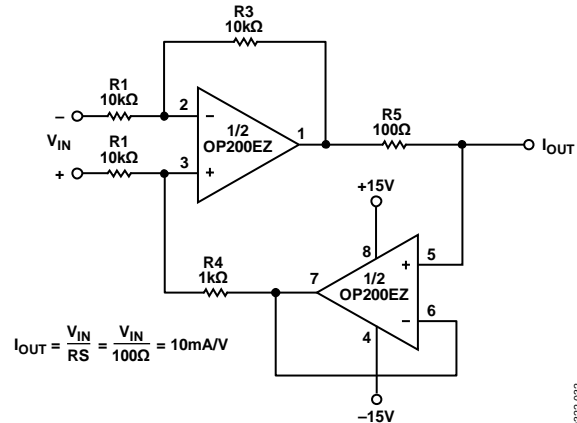

Figure 32. Precision Current Pump

**DUAL 12-BIT VOLTAGE OUTPUT DAC**

The dual output DAC shown in Figure 33 is capable of providing untrimmed 12-bit accurate operation over the entire military temperature range. Offset voltage, bias current, and gain errors of the OP200 contribute less than 1/10 of an LSB error at 12 bits over the military temperature range.

**DUAL PRECISION VOLTAGE REFERENCE**

A dual OP200 and a REF43, a 2.5 V reference, can be used to build a  $\pm 2.5$  V precision voltage reference. Maximum output current from each reference is  $\pm 10$  mA with load regulation under  $25 \mu\text{V}/\text{mA}$ . Line regulation is better than  $15 \mu\text{V}/\text{V}$  and output voltage drift is under  $20 \mu\text{V}/^\circ\text{C}$ . Output voltage noise from 0.1 Hz to 10 Hz is typically  $75 \mu\text{V}$  p-p. R1 and D1 ensure correct startup.

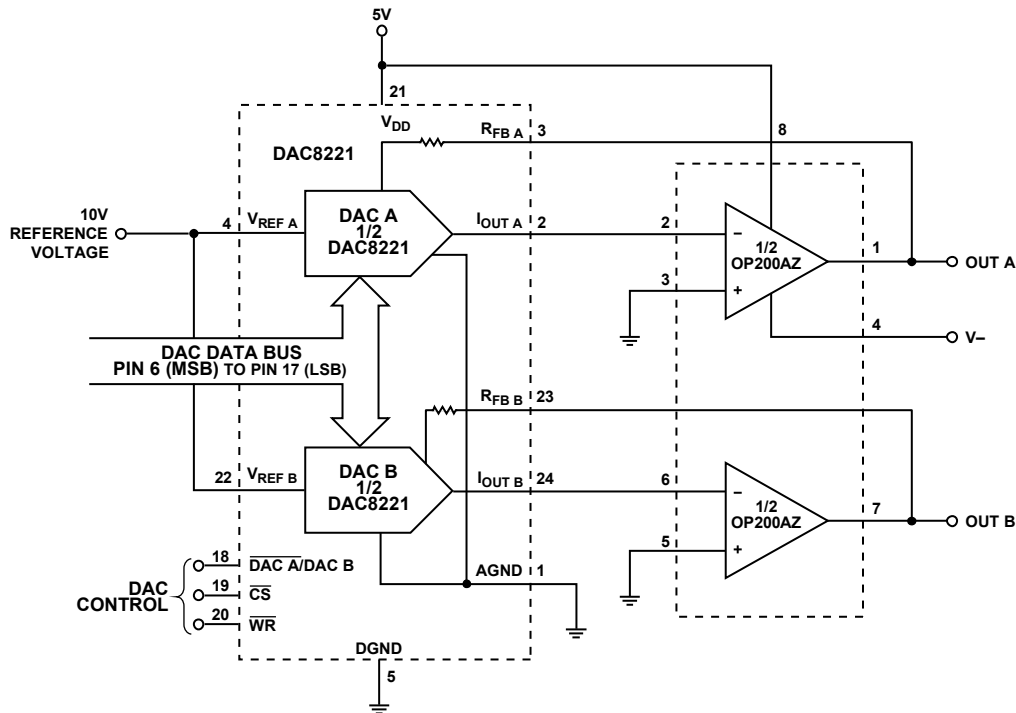

Figure 33. Dual 12-Bit Voltage Output DAC

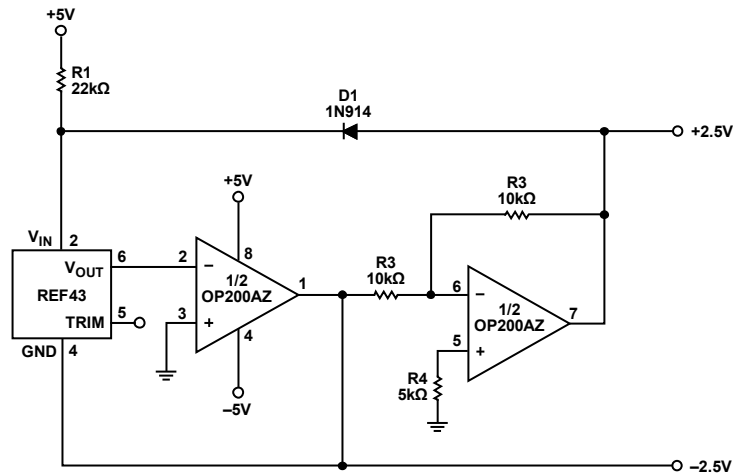

Figure 34. Dual Precision Voltage Reference

**PROGRAMMABLE HIGH RESOLUTION WINDOW COMPARATOR**

The programmable window comparator shown in Figure 35 is easily capable of 12-bit accuracy over the full military temperature

range. A dual CMOS 12-bit DAC, the DAC8221, is used in the voltage switching mode to set the upper and lower thresholds (DAC A and DAC B, respectively).

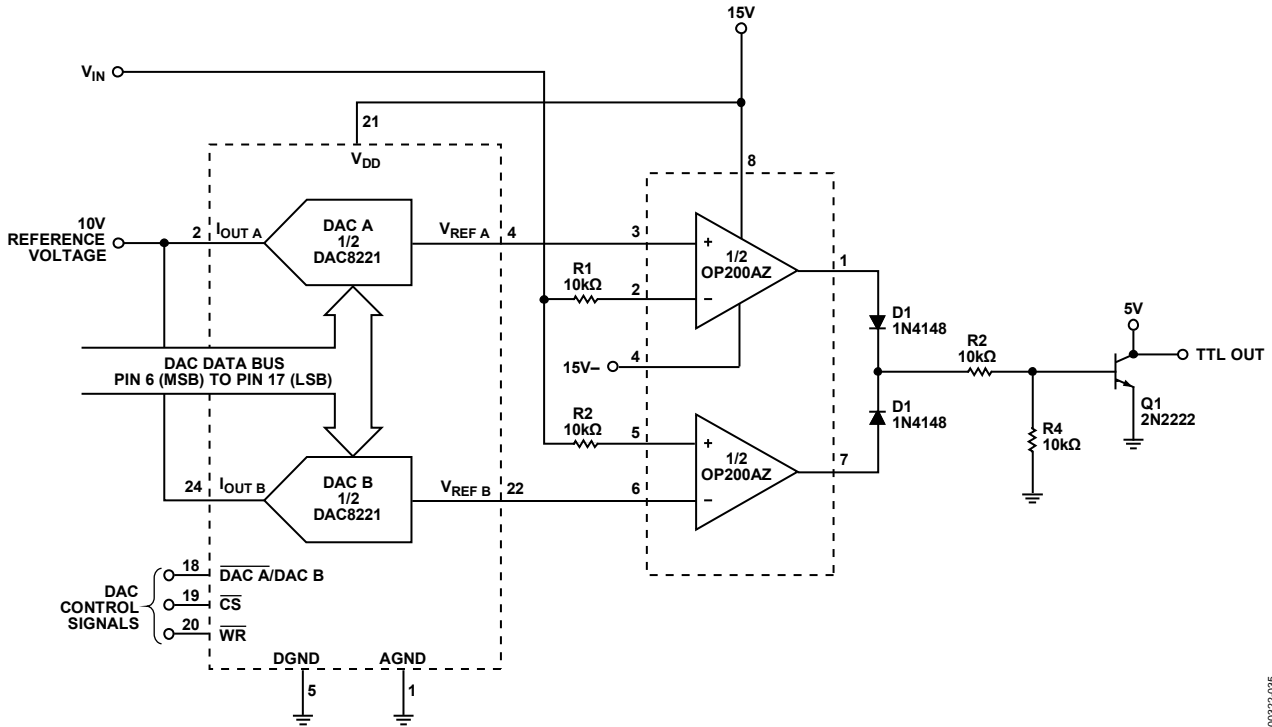
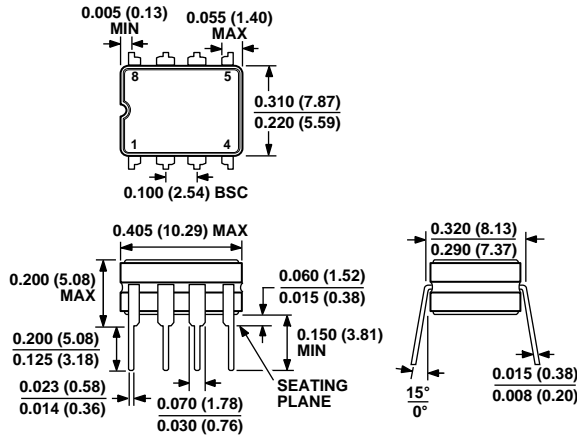

Figure 35. Programmable High Resolution Window Comparator

00322-085

# OUTLINE DIMENSIONS



CONTROLLING DIMENSIONS ARE IN INCHES; MILLIMETER DIMENSIONS (IN PARENTHESES) ARE ROUNDED-OFF INCH EQUIVALENTS FOR REFERENCE ONLY AND ARE NOT APPROPRIATE FOR USE IN DESIGN.

Figure 36. 8-Lead Ceramic Dual In-Line Package [CERDIP]  
(Q-8)  
Z-Suffix

Dimensions shown in inches and (millimeters)

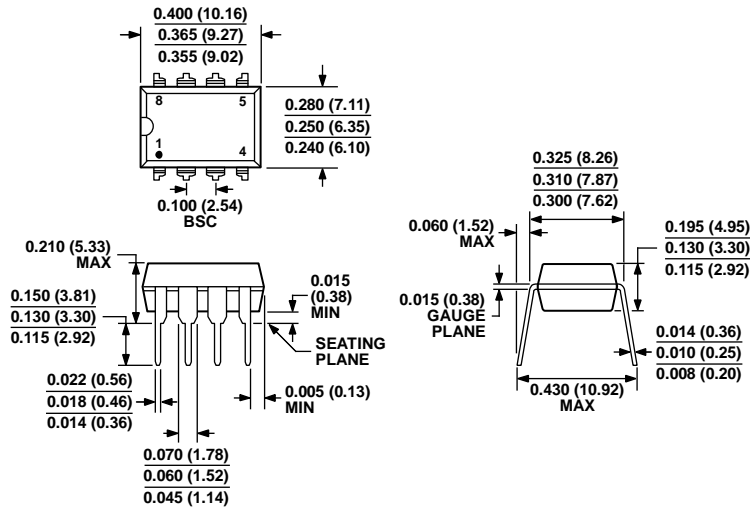

COMPLIANT TO JEDEC STANDARDS MS-001  
CONTROLLING DIMENSIONS ARE IN INCHES; MILLIMETER DIMENSIONS (IN PARENTHESES) ARE ROUNDED-OFF INCH EQUIVALENTS FOR REFERENCE ONLY AND ARE NOT APPROPRIATE FOR USE IN DESIGN. CORNER LEADS MAY BE CONFIGURED AS WHOLE OR HALF LEADS.

Figure 37. 8-Lead Plastic Dual In-Line Package [PDIP]  
(N-8)  
P-Suffix

Dimensions shown in inches and (millimeters)

070606-A

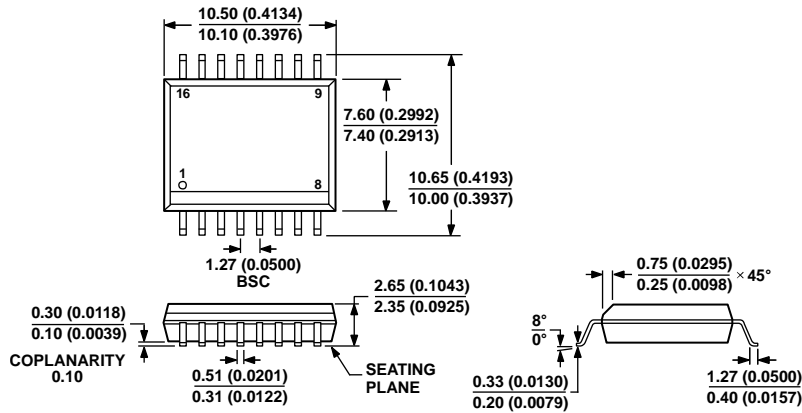

COMPLIANT TO JEDEC STANDARDS MS-013-AA  
 CONTROLLING DIMENSIONS ARE IN MILLIMETERS; INCH DIMENSIONS  
 (IN PARENTHESES) ARE ROUNDED-OFF MILLIMETER EQUIVALENTS FOR  
 REFERENCE ONLY AND ARE NOT APPROPRIATE FOR USE IN DESIGN.

Figure 38. 16-Lead Standard Small Outline Package [SOIC\_W]  
 Wide Body  
 (RW-16)  
 S-Suffix

Dimensions shown in millimeters and (inches)

03-27-2007-B

**ORDERING GUIDE**

Model <sup>1</sup>	T <sub>A</sub> = 25°C V <sub>OS</sub> Max (μV)	Temperature Range	Package Description	Package Option
OP200AZ	75	-55°C to +125°C	8-Lead CERDIP	Z-Suffix (Q-8)
OP200EZ	75	-40°C to +85°C	8-Lead CERDIP	Z-Suffix (Q-8)
OP200GPZ	200	-40°C to +85°C	8-Lead PDIP	P-Suffix (N-8)
OP200GS	200	-40°C to +85°C	16-Lead SOIC_W	S-Suffix (RW-16)
OP200GSZ	200	-40°C to +85°C	16-Lead SOIC_W	S-Suffix (RW-16)
OP200GSZ-REEL	200	-40°C to +85°C	16-Lead SOIC_W	S-Suffix (RW-16)

<sup>1</sup> Z = RoHS Compliant Part.