

D I O D E

60A Avg 800 Volts

PC 608
PD 608

■ 回路図 CIRCUIT

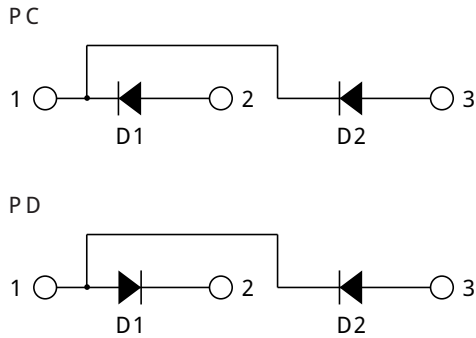

■ 外形寸法図 OUTLINE DRAWING (単位 Dimension : mm)

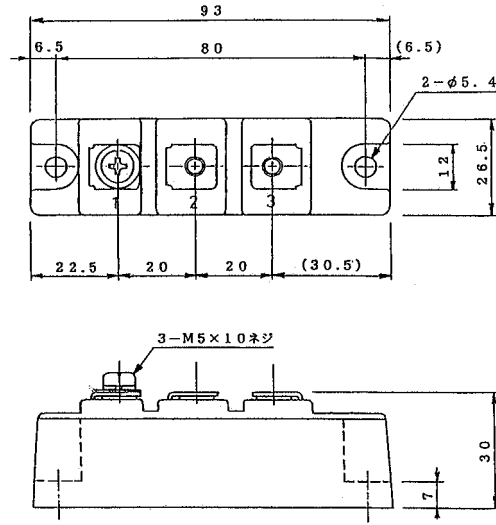

■ 最大定格 Maximum Ratings

項目 Parameter	記号 Symbol	耐压クラス Grade	単位 Unit
		PC 608/PD 608	
くり返しピーク逆電圧 Repetitive Peak Reverse Voltage	V_{RRM}	800	V
非くり返しピーク逆電圧 Non Repetitive Peak Reverse Voltage	V_{RSM}	960	V

項目 Parameter	記号 Symbol	条件 Conditions	定格値 Max. Rated Value	単位 Unit	
平均整流電流 Average Rectified Output Current	$I_{O(AV)}$	商用周波数 180° 通電 Half Sine Wave $T_c = 114^\circ\text{C}$	60	A	
実効順電流 RMS Forward Current	$I_{F(RMS)}$		94	A	
サージ順電流 Surge Forward Current	I_{FSM}	50Hz正弦半波, 1 サイクル, 非くり返し Half Sine Wave, 1 Pulse, Non-Repetitive	1200	A	
電流二乗時間積 I Squared t	I^2t	2 ~ 10ms	7200	A^2s	
動作接合温度範囲 Operating Junction Temperature Range	T_{jw}		- 40 ~ + 150	$^\circ\text{C}$	
保存温度範囲 Storage Temperature Range	T_{stg}		- 40 ~ + 125	$^\circ\text{C}$	
絶縁耐圧 Isolation Voltage	V_{iso}	端子 - ベース間, AC 1 分間 Terminal to Base, AC 1 min.	2000	V	
締付トルク Mounting Torque	ベース部 Mounting	サーマルコンパウンド塗布 Greased	M5	2.4 ~ 2.8	N·m
	主端子部 Terminal		M5	2.4 ~ 2.8	N·m

■ 電気的特性 Electrical Characteristics

項目 Parameter	記号 Symbol	条件 Conditions	特性値 (最大) Maximum Value	単位 Unit
ピーク逆電流 Peak Reverse Current	I_{RM}	$T_j = 150^\circ\text{C}, V_{RM} = V_{RRM}$	15	mA
ピーク順電圧 Peak Forward Voltage	V_{FM}	$T_j = 25^\circ\text{C}, I_{FM} = 180\text{A}$	1.25	V
熱抵抗 Thermal Resistance	$R_{th(j-c)}$	接合部 - ケース間 Junction to Case	0.5	$^\circ\text{C}/\text{W}$
接触熱抵抗 Thermal Resistance	$R_{th(c-f)}$	ケース - フィン間, サーマルコンパウンド塗布 Case to Fin, Greased	0.2	$^\circ\text{C}/\text{W}$

質量... 約155g
Approximate Weight

*1 : 1 アーム当りの値 Value Per 1 Arm.

順電圧特性
FORWARD CURRENT VS. VOLTAGE

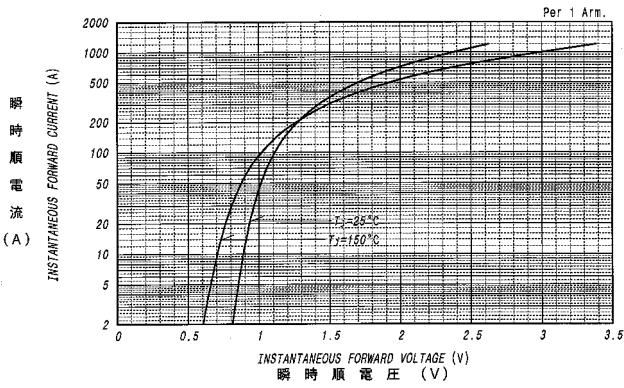

平均順電力損失特性
AVERAGE FORWARD POWER DISSIPATION

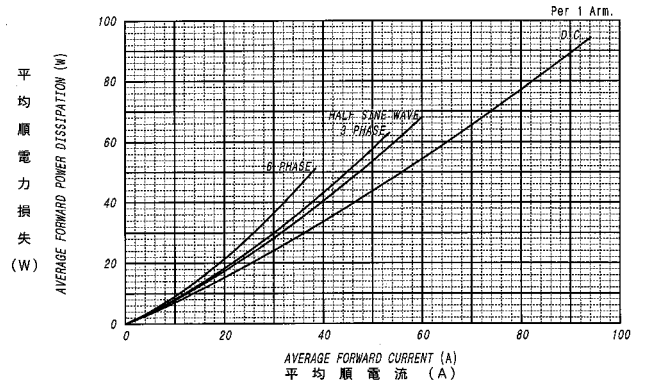

平均順電流 - ケース温度定格
AVERAGE FORWARD CURRENT VS. CASE TEMPERATURE

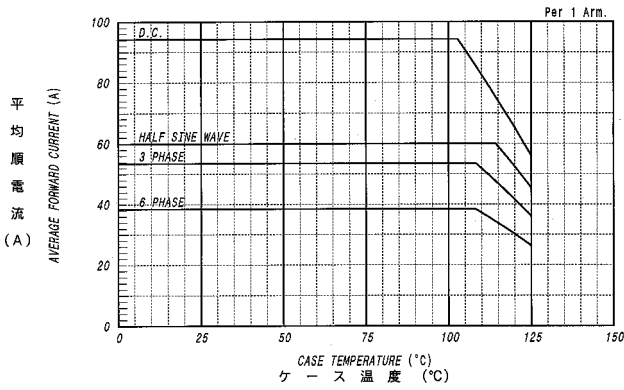

サージ順電流定格
SURGE CURRENT RATINGS

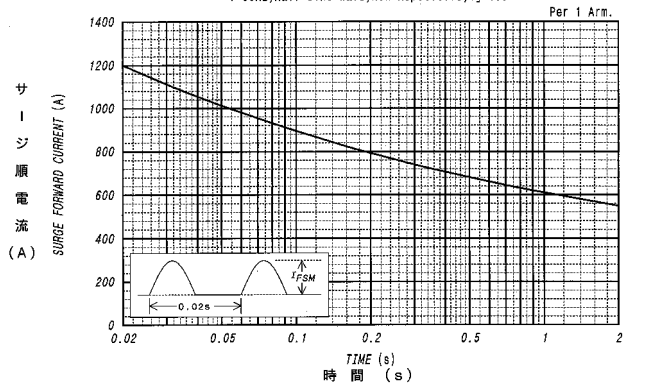

過渡熱抵抗特性
MAXIMUM TRANSIENT THERMAL IMPEDANCE
Junction to Case

