

# DATA SHEET

## **PCF5083** GSM signal processing IC

Objective specification  
File under Integrated Circuits, IC17

1996 Oct 29

**GSM signal processing IC****PCF5083****CONTENTS**

1	FEATURES	9.1.3	Audio and Data Interface
2	GENERAL DESCRIPTION	9.1.4	Audio interface
3	APPLICATIONS	9.1.5	Terminal adaptor interface for data services
4	ORDERING INFORMATION	9.1.6	System controller interface
5	BLOCK DIAGRAM	9.1.7	Event Counter Clock
6	PINNING INFORMATION	9.1.8	Usage of General Purpose I/O Pins
6.1	Pinning	9.1.9	Power saving modes
6.2	Pinning description	9.2	Message Interface to the System Controller
7	OVERVIEW OF THE GSM CHIP SET	9.2.1	Execution of GSM baseband procedures
7.1	General	9.2.2	No Operation (NOP) command
7.2	The role of the PCF5083	9.2.3	Soft resetting the DSP
8	FUNCTIONAL DESCRIPTION TIMER CORE	9.2.4	Error handling
8.1	Clock generator	9.3	GSM baseband procedures
8.2	ON/OFF Logic	9.3.1	Procedure description
8.2.1	Mobile switch-on procedure	9.3.2	Performance of GSM baseband procedures
8.2.2	Mobile switch-off procedure	9.4	Software applications
8.2.3	OFF/Watchdog Timer	9.4.1	Receiving a CCH block
8.3	Timing Generator	9.4.2	Transmitting a CCH block
8.3.1	The Quarterbit Counter	9.4.3	FB search for timing synchronization
8.3.2	Normal Mode	9.4.4	Processing a TCH/FS multiframe
8.3.3	Sleep Mode	10	MICROCONTROLLER INTERFACE
8.4	RF-IC Interface Bus	10.1	Register Set for the Timer Core
8.4.1	Frequency Setting Channel	10.2	Interrupt Logic
8.4.2	Gain Control Channel	11	RESET
8.4.3	Immediate Control Channel	12	JTAG TEST INTERFACE
8.4.4	Operation Modes and Control Registers	13	TEST AND EMULATION MODES
8.5	IOM <sup>®</sup> -2 Interface	14	LIMITING VALUES
8.5.1	IOM <sup>®</sup> -2 Clock Generation	15	DC CHARACTERISTICS
8.5.2	IOM <sup>®</sup> -2 Master Unit	16	AC CHARACTERISTICS
8.5.3	Monitor Channel Transmitter Protocol	17	APPLICATION INFORMATION
8.5.4	Monitor Channel Receiver Protocol	18	PACKAGE OUTLINE
8.5.5	Command/Indication Channel Transmitter	19	SOLDERING
8.5.6	Command/Indication Channel Receiver	19.1	Introduction
8.5.7	Audio Interface	19.2	Reflow soldering
8.5.8	External IOM <sup>®</sup> -2 Interface	19.3	Wave soldering
8.6	MMI Interface	19.4	Repairing soldered joints
8.6.1	RS232 Interface	20	DEFINITIONS
8.6.2	MMI power-down Interface	21	LIFE SUPPORT APPLICATIONS
8.7	General purpose parallel I/O-port		
8.8	Real Time Clock		
8.8.1	Setting the real time clock		
9	DESCRIPTION OF THE DSP CORE		
9.1	Interface description		
9.1.1	Baseband Digitizer Interface		
9.1.2	GMSK Modulator Interface		

## GSM signal processing IC

## PCF5083

**1 FEATURES**

- Fabricated in a 0.5  $\mu\text{m}$  CMOS process with 3-layer metal
- LQFP128 package (SOT420AA-2)
- 3.3 V operation
- Low power
- Embedded DSP core for all GSM specific signal processing tasks:
  - 16-bit fixed point DSP
  - 19.5 MHz or external clock operation
  - Flexible power-down modes
  - 5 kbyte on-chip program or data RAM
  - 2 kbyte on-chip data ROM
  - 16 kbyte on-chip program ROM
  - Fully pre-programmed modules for GSM baseband tasks including all data channels
  - Dedicated GSM signal processor with application specific hardware for: equalisation, channel encoding/decoding for all traffic and control channels and encryption/decryption (A5/1 and A5/2 algorithms)
  - Tone and side-tone generation
- GSM Hardware Timer and Interface core:
  - Power saving Sleep mode for GSM mobiles
  - Programmable TDMA timing and power-down signals with 0.25 bit resolution
  - Three wire serial control bus for fast programming of RF ICs and synthesizers
  - IOM<sup>®</sup>-2 interface for external accessories, host software download and support of the Digital Audio Interface (DAI)

- RS232 interface for the man machine interface controller
- Man machine interface power-down control
- Power supply control logic with Watchdog Timer
- Real time clock and calendar running on 32.768 kHz
- 6-bit general purpose I/O port
- Reduced swing 13 MHz main clock input
- On-chip PLL to derive the DSP and microcontroller clock
- 8-bit, 68000 compatible host interface with three interrupt lines
- Boundary scan interface in accordance with "IEEE Standard 1149.1-1990".

**2 GENERAL DESCRIPTION**

The PCF5083 GSM Signal Processing IC is a dedicated VLSI circuit; fabricated in a 0.5  $\mu\text{m}$  CMOS process. It has been designed for baseband signal processing tasks for the Pan European Global System for Mobile telecommunication (GSM). The PCF5083 is part of the second generation Philips Semiconductors GSM chip set.

The PCF5083 consists of an embedded 16-bit DSP core for all GSM specific signal processing tasks and a Timer and Interface core which contains many peripheral functions to simplify the system design.

**3 APPLICATIONS**

The PCF5083 is suitable for use in GSM mobile stations or hand-helds.

**4 ORDERING INFORMATION**

TYPE NUMBER	PACKAGE		
	NAME	DESCRIPTION	VERSION
PCF5083H/F2	LQFP128	plastic low profile quad flat package; 128 leads; (PCF5083-2B)	SOT420-1
PCF5083H/001/F2	LQFP128	plastic low profile quad flat package; 128 leads; (PCF5083-2C)	SOT420-1
PCF5083H/5V2/F3	LQFP128	plastic low profile quad flat package; 128 leads; (PCF5083-3A)	SOT420-1

GSM signal processing IC

PCF5083

5 BLOCK DIAGRAM

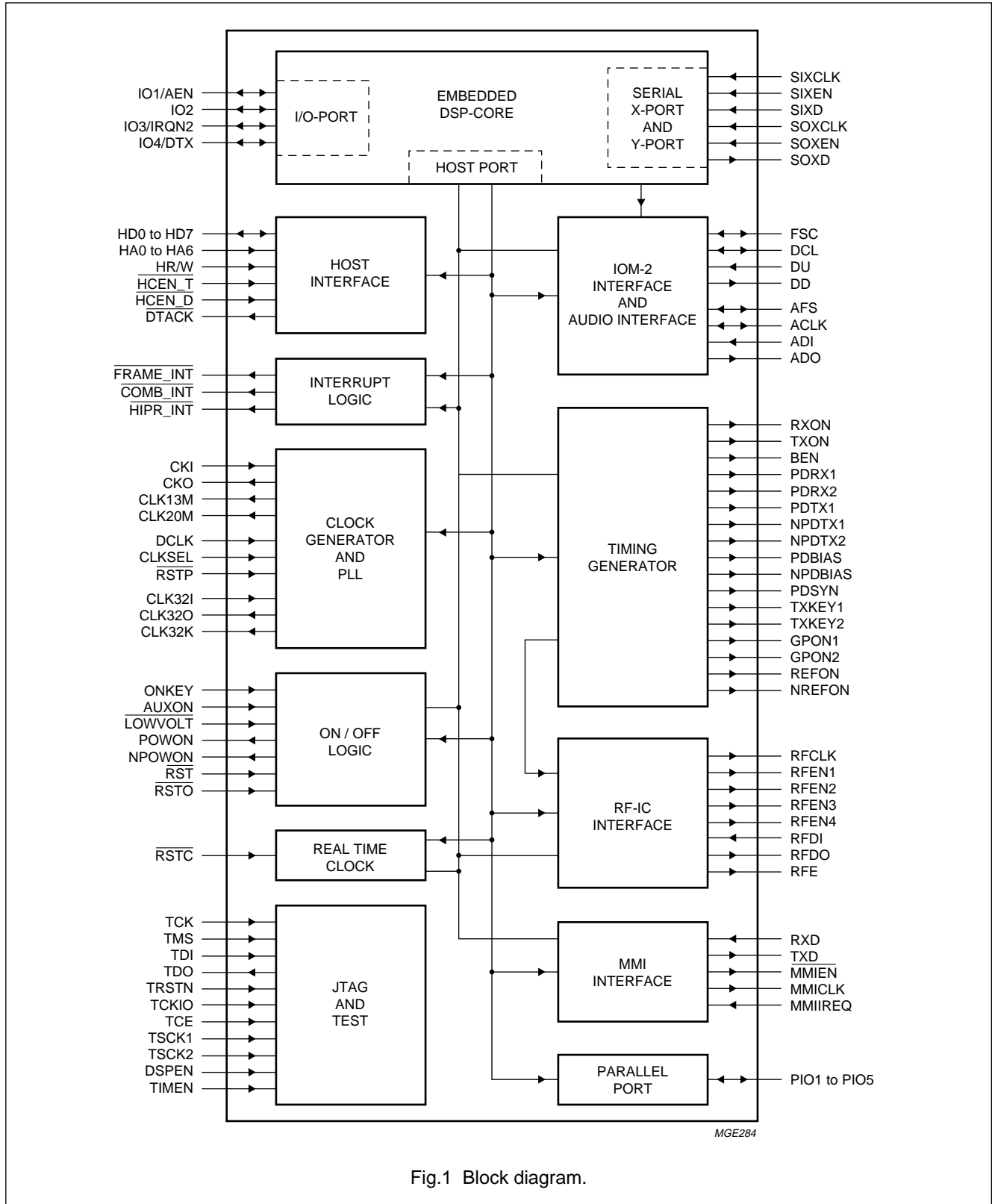

Fig.1 Block diagram.

GSM signal processing IC

PCF5083

6 PINNING INFORMATION

6.1 Pinning

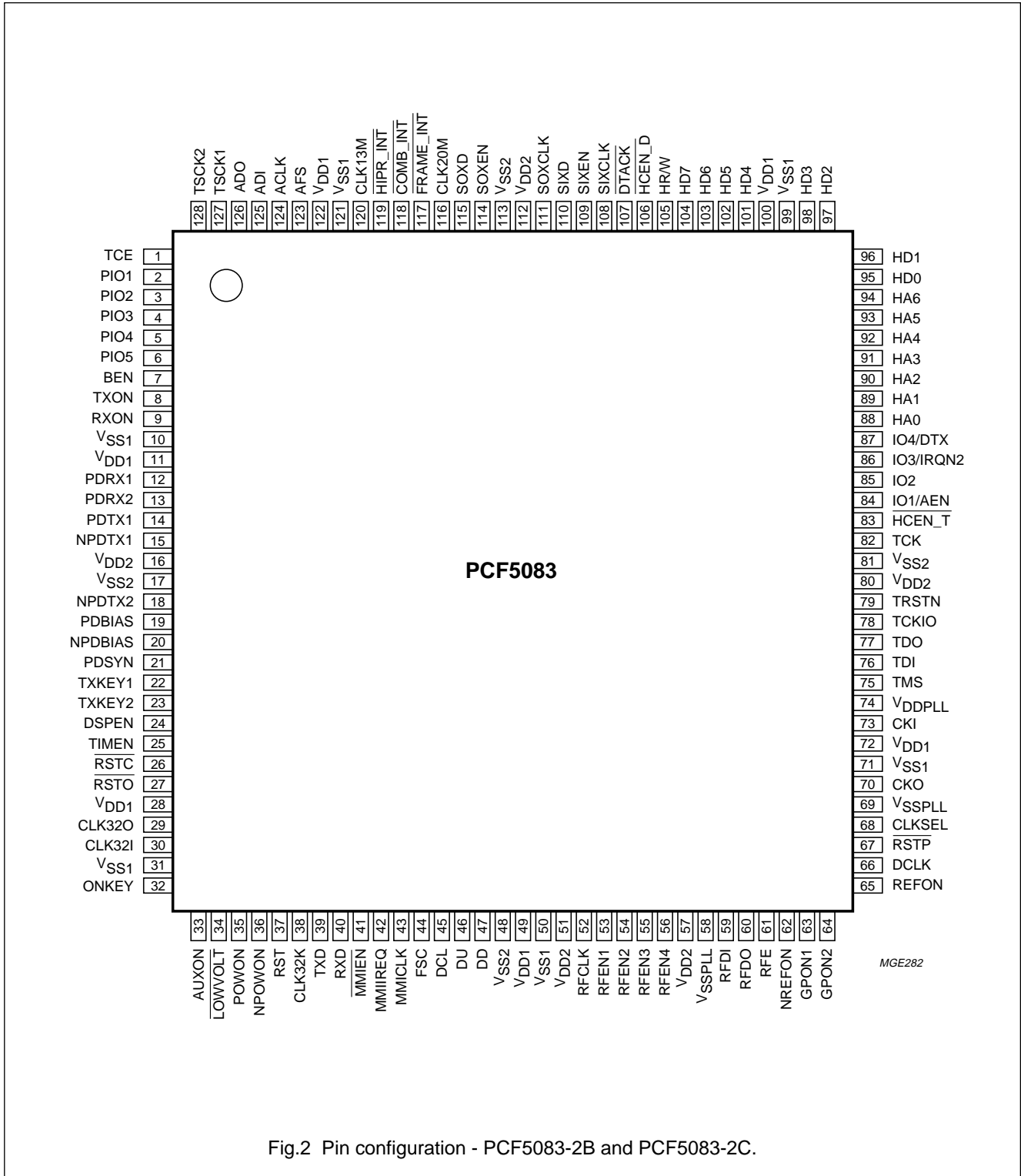

Fig.2 Pin configuration - PCF5083-2B and PCF5083-2C.

GSM signal processing IC

PCF5083

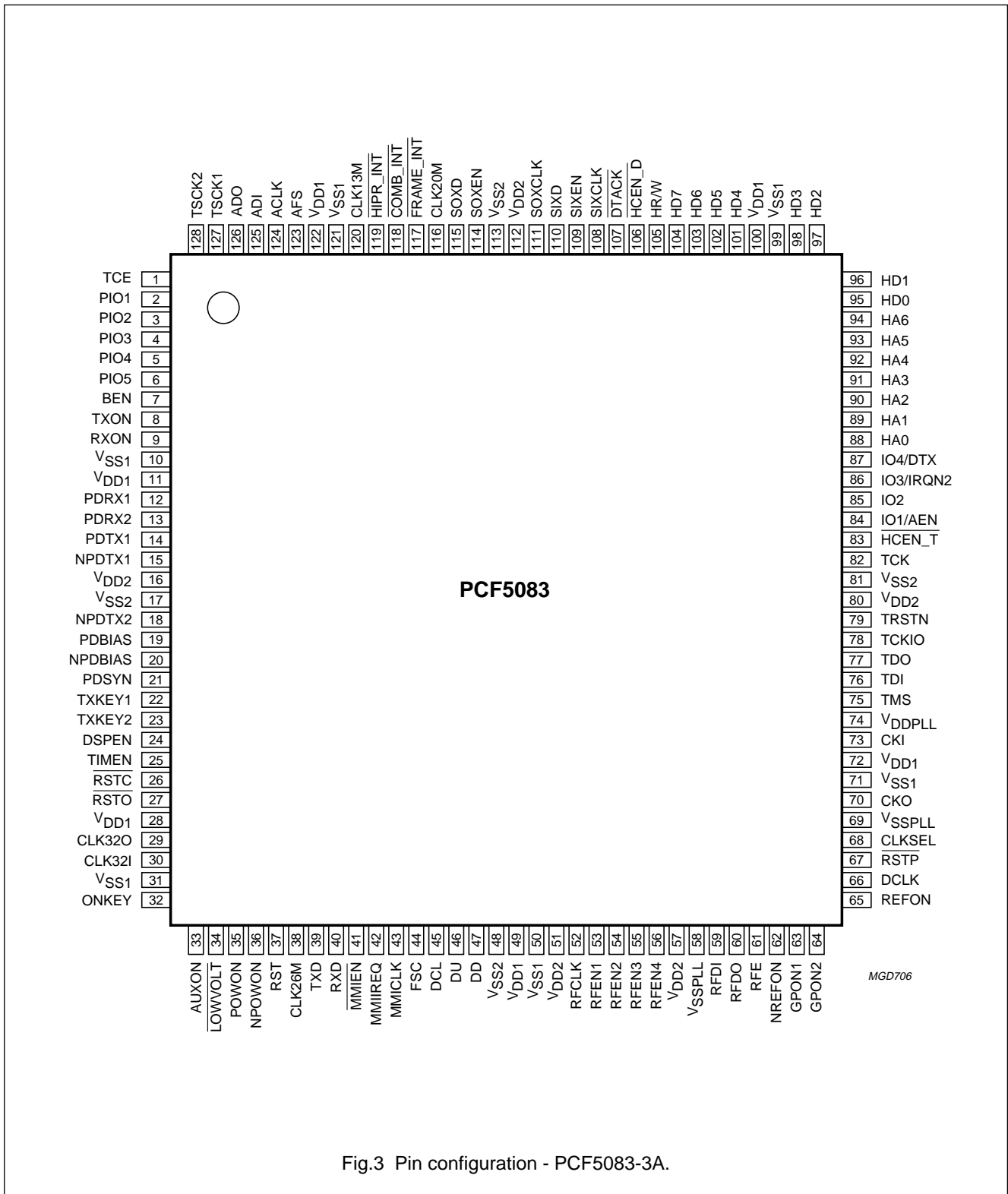

Fig.3 Pin configuration - PCF5083-3A.

## GSM signal processing IC

## PCF5083

## 6.2 Pinning description

SYMBOL	PIN	I/O	DESCRIPTION
TCE	1	I	Test Clock Enable (active HIGH); tied to $V_{SS}$ during normal operation.
PIO1 to PIO5	2 to 6	I/O	General purpose parallel port (3-state output).
BEN	7	O	Baseband Port Enable (active HIGH, 3-state).
TXON	8	O	Modulator window enable (active HIGH, 3-state).
RXON	9	O	Receiver window enable (active HIGH, 3-state).
$V_{SS1}$	10		Ground I/O pin.
$V_{DD1}$	11		Supply I/O pin.
PDRX1	12	O	Receiver Power-down 1 (active HIGH, 3-state).
PDRX2	13	O	Receiver Power-down 2 (active HIGH, 3-state).
PDTX1	14	O	Transmitter Power-down 1 (active HIGH, 3-state).
NPDTX1	15	O	Inverted output of PDTX1 (active LOW, 3-state).
$V_{DD2}$	16		Supply core.
$V_{SS2}$	17		Ground core.
NPDTX2	18	O	Transmitter Power-down 2 (active LOW, 3-state).
PDBIAS	19	O	Transmitter power supply Power-down (active HIGH, 3-state).
NPDBIAS	20	O	Inverted output of PDBIAS (active LOW, 3-state).
PDSYN	21	O	Synthesizer Power-down (active HIGH, 3-state).
TXKEY1	22	O	Power ramping control (active HIGH, 3-state).
TXKEY2	23	O	Power module control (active HIGH, 3-state).
DSPEN	24	I	DSP Test Mode Enable (active HIGH). PCF5083-2B includes an internal pull-down resistor. PCF5083-2C does not include an internal pull-down resistor.
TIMEN	25	I	Timer Test Mode Enable (active HIGH). PCF5083-2B includes an internal pull-down resistor. PCF5083-2C does not include an internal pull-down resistor.
$\overline{RSTC}$	26	I	Asynchronous Reset - real time clock (active LOW, CMOS level Schmitt trigger input).
$\overline{RSTO}$	27	I	Asynchronous Reset - ON/OFF logic (active LOW, CMOS level Schmitt trigger input).
$V_{DD1}$	28		Supply I/O pin.
CLK32O	29	O	32.768 kHz crystal oscillator output.
CLK32I	30	I	32.768 kHz crystal oscillator input.
$V_{SS1}$	31		Ground I/O pin.
ONKEY	32	I	ON/OFF Key input (active HIGH, CMOS level Schmitt trigger input with internal pull-down resistor).

## GSM signal processing IC

## PCF5083

SYMBOL	PIN	I/O	DESCRIPTION
AUXON	33	I	Auxiliary Switch on input (active HIGH, CMOS level Schmitt trigger input).
$\overline{\text{LOWVOLT}}$	34	I	Low battery indication (active LOW, CMOS level Schmitt trigger input).
POWON	35	O	Power Regulator on (active HIGH).
$\overline{\text{NPOWON}}$	36	O	Power Regulator on (active LOW).
$\overline{\text{RST}}$	37	I	Asynchronous Reset for timer section (active LOW, CMOS level Schmitt trigger input).
CLK32K	38	O	The 32.768 kHz CMOS level output for PCF5083-2B and PCF5083-2C.
CLK26M			The 26 MHz CMOS level output for PCF5083-3.
TXD	39	O	RS232 transmit data output (open-drain output).
RXD	40	I	RS232 receive data input.
$\overline{\text{MMIEN}}$	41	O	RS232 input buffer full indication (active LOW, open-drain output).
MMIREQ	42	I	MMI clock request (active HIGH, CMOS level Schmitt trigger input).
MMICLK	43	O	MMI clock 13 MHz.
FSC	44	I/O	IOM <sup>®</sup> -2 frame pulse (3-state).
DCL	45	I/O	IOM <sup>®</sup> -2 clock (3-state).
DU	46	I	IOM <sup>®</sup> -2 data input (CMOS level Schmitt trigger input).
DD	47	O	IOM <sup>®</sup> -2 data output (open drain output).
V <sub>SS2</sub>	48		Ground core.
V <sub>DD1</sub>	49		Supply I/O pin.
V <sub>SS1</sub>	50		Ground I/O pin.
V <sub>DD2</sub>	51		Supply core.
RFCLK	52	O	RF-IC interface shift clock (3-state).
RFEN1	53	O	RF-IC Interface Enable 1 (active LOW, 3-state).
RFEN2	54	O	RF-IC Interface Enable 2 (active LOW, 3-state).
RFEN3	55	O	RF-IC Interface Enable 3 (active LOW, 3-state).
RFEN4	56	O	RF-IC Interface Enable 4 (active LOW, 3-state).
V <sub>DD2</sub>	57		Supply core.
V <sub>SSPLL</sub>	58		Ground for PLL.
RFDI	59	I	RF-IC Interface data in.
RFDO	60	O	RF-IC Interface data out (3-state).
RFE	61	O	RF-IC Interface Enable (active HIGH, 3-state).
NREFON	62	O	Reference oscillator power-down (active LOW, 3-state).



## GSM signal processing IC

## PCF5083

SYMBOL	PIN	I/O	DESCRIPTION
GPON1	63	O	Sleep mode power-down 1 (active HIGH, 3-state).
GPON2	64	O	Sleep mode power-down 2 (active HIGH, open-drain output).
REFON	65	O	Sleep mode power-down 3 (active HIGH, 3-state).
DCLK	66	I	External DSP clock input.
RSTP	67	I	PLL reset (active LOW with internal pull-down resistor).
CLKSEL	68	I	Timer clock source select.
V <sub>SSPLL</sub>	69		Ground for PLL.
CKO	70	O	Low swing input buffer output.
V <sub>SS1</sub>	71		Ground I/O pin.
V <sub>DD1</sub>	72		Supply I/O pin.
CKI	73	I	Reference clock input, low swing input 13 kHz.
V <sub>DDPLL</sub>	74		Supply for PLL.
TMS	75	I	JTAG port mode select (with internal pull-down resistor).
TDI	76	I	JTAG port data input (with internal pull-down resistor).
TDO	77	O	JTAG port data output.
TCKIO	78	I	Auxiliary test signal - tied to V <sub>SS</sub> during operation.
TRSTN	79	I	JTAG port reset (with internal pull-down resistor).
V <sub>DD2</sub>	80		Supply core.
V <sub>SS2</sub>	81		Ground core.
TCK	82	I	JTAG port clock input (with internal pull-down resistor).
HCEN_T	83	I	Host Interface Enable - Timer core (active LOW).
IO1/AEN	84	I/O	DSP general purpose I/O used for voice port control (CMOS level I/O). The PCF5083-3 has its own internal pull-up resistor however, both the PCF5083-2B and PCF5083-2C require a pull-up resistor.
IO2	85	I/O	DSP general purpose I/O used for voice port control (CMOS level I/O). The PCF5083-3 has its own internal pull-up resistor however, both the PCF5083-2B and PCF5083-2C require a pull-up resistor.
IO3/IRQN2	86	I/O	DSP general purpose I/O or Interrupt Request Input 2 (CMOS level I/O). The PCF5083-3 has its own internal pull-up resistor however, both the PCF5083-2B and PCF5083-2C require a pull-up resistor.
IO4/DTX	87	I/O	DSP general purpose I/O (CMOS level I/O, external pull-up resistor required).
HA0 to HA6	88 to 94	I	Host Interface Address.
HD0 to HD3	95 to 98	I/O	Host Interface Data (3-state).

## GSM signal processing IC

## PCF5083

SYMBOL	PIN	I/O	DESCRIPTION
V <sub>SS1</sub>	99		Ground I/O pin.
V <sub>DD1</sub>	100		Supply I/O pin.
HD4 to HD7	101 to 104	I/O	Host Interface data (3-state).
HR/W	105	I	Host Interface Write Enable.
HCEN_D	106	I	Host Interface Enable - DSP core (active LOW).
DTACK	107	O	Host port acknowledge - used as DTACK from DSP core (active LOW, open-drain output).
SIXCLK	108	I	DSP serial input port X clock (CMOS level Schmitt trigger input).
SIXEN	109	I	DSP serial input port X enable.
SIXD	110	I	DSP serial input port X data.
SOXCLK	111	I	DSP serial output port X clock (CMOS level Schmitt trigger input).
V <sub>DD2</sub>	112		Supply core.
V <sub>SS2</sub>	113		Ground core.
SOXEN	114	I	DSP serial output port X enable.
SOXD	115	O	DSP serial output port X data (3-state).
CLK20M	116	O	19.5 MHz CMOS level output.
FRAME_INT	117	O	TDMA frame interrupt (active LOW, open drain output).
COMB_INT	118	O	Combined interrupt (active LOW, open drain output).
HIPR_INT	119	O	High Priority Interrupt (active LOW, open drain output).
CLK13M	120	O	13 MHz CMOS level output.
V <sub>SS1</sub>	121		Ground I/O pin.
V <sub>DD1</sub>	122		Supply I/O pin.
AFS	123	I/O	Audio Interface frame sync signal (3-state).
ACLK	124	I/O	Audio Interface Clock (3-state).
ADI	125	I	Audio Interface Data In, RS232 clock if enabled.
ADO	126	O	Audio Interface Data Out (3-state).
TSCK1	127	I	Test Clock 1 - tied to V <sub>SS</sub> during normal operation.
TSCK2	128	I	Test Clock 2 - tied to V <sub>DD2</sub> during normal operation.

## GSM signal processing IC

## PCF5083

### 7 OVERVIEW OF THE GSM CHIP SET

#### 7.1 General

The chip set's high-level architectural modularity ensures that it can be easily adapted to meet various market requirements in terms of hardware and software. Figure 4 is a simplified block diagram of a GSM terminal using the Philips Semiconductors chip set.

The receiver converts the antenna input signal from 890 to 915 MHz down into a complex baseband signal consisting of an in-phase (I) and a quadrature component (Q). In order to deal with the high dynamic range from  $-104$  to  $-10$  dBm, the receiver provides an AGC input controlled by the layer 1 software in the System Controller. The complex baseband signal is connected to the input of the PCF5072 baseband interface IC. This IC samples the I and Q components at the GSM bit clock (270 kHz) with an accuracy of approximately  $2 \times 13$  bits.

The equalizer is responsible for the following tasks:

- Channel impulse response estimation and bit synchronization by means of the training sequence
- Adaptive channel equalization with a modified Maximum Likelihood Sequence Estimation (MLSE) approach that produces a bit-by-bit soft decision information (Channel Measurement Information (CMI))
- Channel impulse response adaption and frequency offset estimation.

After decryption the channel decoder performs convolutional and block decoding. Depending on the logical channel in use, there are decoding schemes for TCH/F (FACCH/F), SACCH and SDCCH.

The speech decoder synthesises the audio signal from the received bit stream. Updating of comfort noise parameters occurs each time a valid Silence Descriptor (SID) is received. Comfort noise is inserted during periods of speech pauses. Substitution and muting of lost or bad frames is implemented.

The full rate speech encoder collects speech samples of 13-bit uniform PCM format (104 kbits/s) and compresses them to 13 kbits/s according to the linear predictive coding, long term prediction, Regular Pulse Excitation (RPE-LTP). Discontinuous Transmission (DTX) is available (voice activity detection, background acoustic noise).

To protect the data from transmission errors, block and convolutional coders form the channel encoder. The encoding modules relates to the logical channels (e.g. RACH, TCH/F (FACCH/F), SDCCH/SACCH).

After encryption the burst builder generates either Normal Bursts (NB) or Access Bursts (AB). The bit-stream is then modulated with a GMSK modulator (Gaussian Minimum Shift Keying) and upconverted in a quadrature mixer to 890 to 915 MHz.

The on-chip GSM timer generates all power-down and control signals for the receiver, the transmitter, the P90CL301 System Controller and the PCF5072 baseband interface IC.

The System Controller (P90CL301) services all HW interfaces and performs the signalling software contained in the GSM layer stack (with L1, L2, L3, O&M, UAP, SIMAP etc).

The voiceband ADCs and DACs of the PCF5072 perform the conversion between the analog audio signals and the digital domain.

#### 7.2 The role of the PCF5083

The PCF5083 is a dedicated VLSI circuit offering baseband signal processing tasks for the Pan European Global System for Mobile telecommunication (GSM). The PCF5083 can be applied in GSM mobile stations or hand-helds. The embedded DSP core is optimized for GSM baseband functions and contains an on-chip program ROM featuring the following tasks:

- Full rate speech coding/decoding including VAD/DTX ("*GSM 06 series*")
- Encryption/decryption according to both A5/1 and A5/2 algorithms ("*GSM Rec. 3.20, 3.21*")
- Burst building supporting access burst and normal burst ("*GSM Rec. 5.02*")
- Frequency Correction Burst (FCB) detection and evaluation
- Synchronization burst (SCH) detection
- BCCH monitoring of neighbouring cells
- Channel coding/decoding and interleaving/de-interleaving ("*GSM Rec. 5.03*") for:
  - Broadcast Channels (BCH): SCH, BCCH
  - Common Control Channels (CCCH): PCH, RACH, AGCH
  - Dedicated Control Channels (DCH): SDCCH, SACCH
  - Traffic Channels (TCH): TCH/FS, TCH/F2.4, TCH/F4.8, TCH/F9.6, TCH/H4.8 and TCH/H2.4
  - Associated Control Channels (ACCH): FACCH and SACCH

## GSM signal processing IC

## PCF5083

- Equalization for normal and synchronization bursts
- Power measurement of serving and neighbouring cells
- Tone and side-tone generation.

2.5 kbytes of RAM are free for downloading of additional software modules e.g. rate adaptation, handsfree, voice recognition.

The DSP communicates via two serial ports to the baseband interface IC and to the IOM<sup>®</sup>-2 Interface and Voice Port for speech and data transmission. For command and data transfer it is connected to a microcontroller via its 8-bit Host Port and the 68000 compatible Host Interface. The I/O port of the DSP core provides four general purpose I/O lines. Some of the port lines are used as dedicated control signals.

The Timer and Interface functions include a GSM specific hardware timer and a couple of interface functions which simplify system design and keep the chip count to a minimum.

The Timing Generator provides the TDMA burst timing and power on/off signals for the RF transmitter, RF receiver, synthesizer, DSP and baseband interface IC. The timing signals can be programmed with an accuracy of a quarterbit ( $\frac{1}{500}$  TDMA frame). Their output polarity is programmable.

The RF-IC Interface is used to program the RF ICs and the synthesizer. It is compatible with the Philips 'Three Wire Bus' and other standards. The bus consists of clock, data and several enable lines to transfer data between the PCF5083 and the connected devices. ICs of one family share the same enable line. Their unique address is a part of the data stream. ICs of different families use separate enable lines.

The PCF5083 includes an IOM<sup>®</sup>-2 Interface to connect external accessories e.g. a handsfree set. It may be used as a software download interface and provides access for the Digital Audio Interface during Type Approval.

The Audio Interface provides the connection between a local codec, the IOM<sup>®</sup>-2 Bus and the DSP.

The ON/OFF Logic performs the basic power-up and power-down switching function for the whole mobile. It controls the supply voltage switches for the terminal. The on/off conditions are controlled via the operators keyboard, a low voltage battery indication circuit, the Watchdog Timer or an auxiliary switch on input for general purpose use.

The man-machine interface section includes a dedicated RS232 interface and generates a 13 MHz clock for the keyboard and card reader controller. If this controller is inactive, the clock is stopped to save power. If the controller requests service, the clock is switched on again.

The PCF5083 includes a 6-bit general purpose parallel port to control system functions. One bit of the port is used on-chip to provide a reset signal for the DSP core.

The PCF5083 is accessed via its 8-bit, 68000 compatible Host Interface. Separate chip enable lines for the DSP and the Timer core are available. The DSP core provides a signal to be used as DTACK for maximum speed operation. Three interrupt lines are provided for the microcontroller.

The PCF5083 requires two clock signals. The 13 MHz main clock is used internally to generate the TDMA timing and as a reference clock for the on-chip PLL. A second clock of 32.768 kHz is used for a real time clock/calendar, a Watchdog Timer and to provide timing in a power reducing Sleep mode. During this mode TDMA timing is maintained with slow running, high accuracy counters, while all timing signals are kept inactive to save power.

The on-chip PLL generates three clocks (13, 39 and 52 MHz) which are manipulated to generate the internal DSP clock (19.5 MHz), a 19.5 MHz output (CLK20M) and a 26 MHz output (CLK26M, only version 3) used by the microcontroller and other system components. The 13 MHz PLL output is used by the Timing Generator in addition to being fed back to the PLL. The nominal duty cycle of the PLL outputs is 50%, independent of the reference clock characteristics. The PLL clock outputs may be used for all system components requiring a symmetric input clock therefore leading to reduced tolerance requirements for the duty cycle of the reference clock.

Other ICs of the Philips second generation GSM chipset are:

- P90CL301: 16-bit 68000 compatible microcontroller
- TDA8005: SIM/MMI-Controller
- PCF5072: Baseband Interface and Audio Codec
- SA1638: IF processing IC
- SA1620: RF processing IC (900 MHz)
- UMA1019: Synthesizer
- PCF5075: Power amplifier controller
- BGY20x: UHF Power Amplifier Module family.

GSM signal processing IC

PCF5083

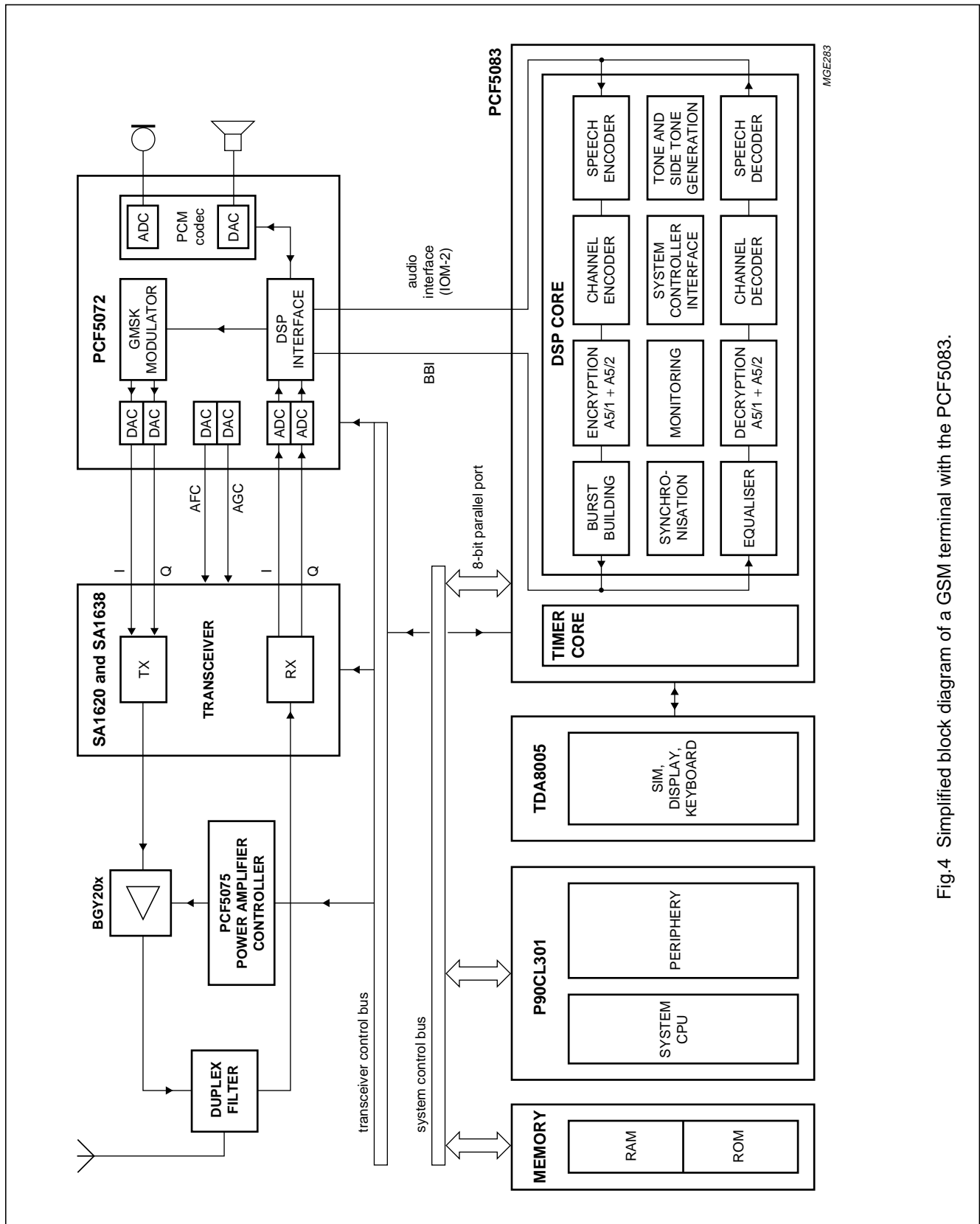

Fig.4 Simplified block diagram of a GSM terminal with the PCF5083.

GSM signal processing IC

PCF5083

8 FUNCTIONAL DESCRIPTION TIMER CORE

8.1 Clock generator

The Clock Generator consists of a low swing input buffer for the 13 MHz reference clock, a PLL as frequency multiplier and a 32.768 kHz crystal oscillator. The PLL generates 13 MHz, 39 MHz and 52 MHz from the 13 MHz reference clock. The PLL reset input  $\overline{RSTP}$  is used to bring the PLL into a low-power state when set to a LOW level.

The 13 MHz reference clock is AC coupled to input CKI. CKI is a reduced swing input which requires a signal in the range of 0.7 V<sub>(p-p)</sub> (worst case) for operation. The clock signal is amplified and used as the input clock for the PLL.

The Timer core is either clocked with the 13 MHz reference clock or the 13 MHz PLL output. The clock source is selected with input CLKSEL as shown in Table 1.

Table 1 Timer Core clock selection

CLKSEL	TIMER CORE CLOCK
0	PLL output
1	buffered CKI input

Using the PLL output reduces the tolerance requirements for the duty cycle of the reference clock.

The DSP core will function with the 39 MHz PLL clock or the clock supplied from DCLK. The clock source is selected with the flags in SYSCON\_REG; see Tables 2 and 3. Within the DSP core the selected clock is first halved before use. The 52 MHz PLL is register selectable for future applications but should not be used in the current implementation of this device

The inverting buffer stage between CLK32I and CLK32O, together with an external crystal network generates a 32.768 kHz clock for the Timer Core. This clock is used for the real time clock, the ON/OFF logic etc.

The internal 13 MHz, 19.5 MHz and 2b/2c: 32.768 kHz/3: 26 MHz clocks are externally available for other system components, e.g. the microcontroller. All clock outputs can be disabled if they are not used to reduce the power consumption.

Table 2 System Configuration Register (SYSCON); note 1

BIT	FLAG	R/W	DESCRIPTION
7	–	–	Reserved
6	LOCK	R	<b>PLL lock select.</b> If LOCK = 0; then PLL in lock. If LOCK = 1; then PLL out of lock.
5	RS232_CLK	W	<b>RS232 interface clock source.</b> If RS232_CLK = 0; then the 13 MHz Timer clock is used. If RS232_CLK = 1; then the RS232 clock is supplied via the ADI pin (pin 125).
4	DSP_CLK1	W	<b>DSP clock select.</b> This two bits select the DSP clock frequency; see Table 3.
3	DSP_CLK0	W	
2	CLK32K <sup>(2)</sup>	W	<b>CLK32K output enable/disable.</b> If CLK32K = 0; then the CLK32K output is enabled. If CLK32K = 1; then the CLK32K output is disabled.
	CLK26M <sup>(3)</sup>		<b>CLK26M output enable/disable.</b> If CLK26M = 0; then the CLK26M output is enabled. If CLK26M = 1; then the CLK26M output is disabled.
1	CLK20M	W	<b>CLK20M output enable/disable.</b> If CLK20M = 0; then the CLK20M output is enabled. If CLK20M = 1; then the CLK20M output is disabled.
0	CLK13M	W	<b>CLK13M output enable/disable.</b> If CLK13M = 0; then the CLK13M output is enabled. If CLK13M = 1; then the CLK13M output is disabled.

Note

1. Default value after reset 0X00 0000b (x: LOCK is undefined).
2. Versions PCF5083-2b and PCF5083-2c only.
3. PCF5083-3 only.

GSM signal processing IC

PCF5083

**Table 3** Selection of the DSP clock

DSP_CLK1	DSP_CLK0	DSP CLOCK
0	0	DCLK/2
0	1	26 MHz
1	0	19.5 MHz
1	1	Reserved

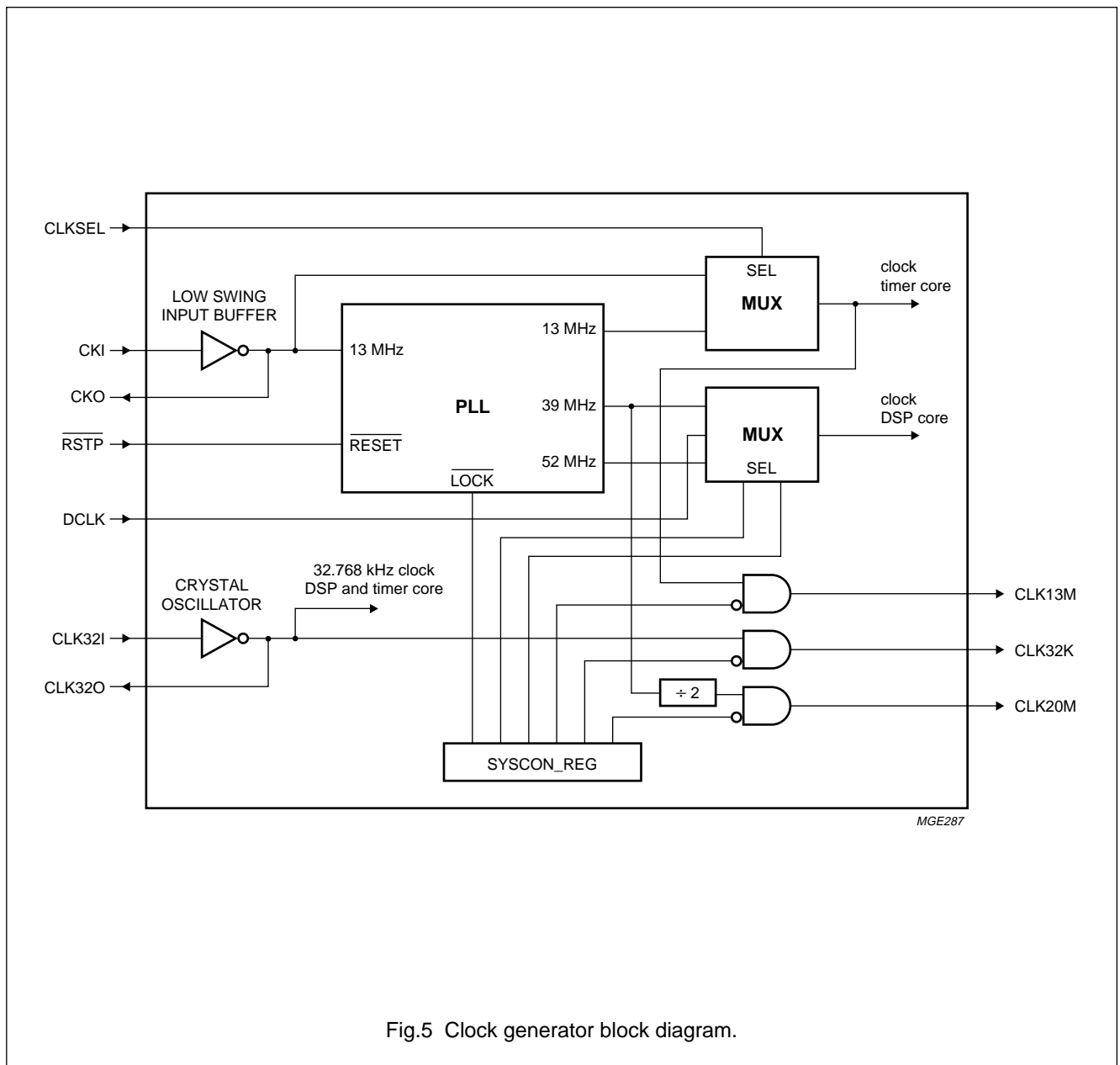

Fig.5 Clock generator block diagram.

GSM signal processing IC

PCF5083

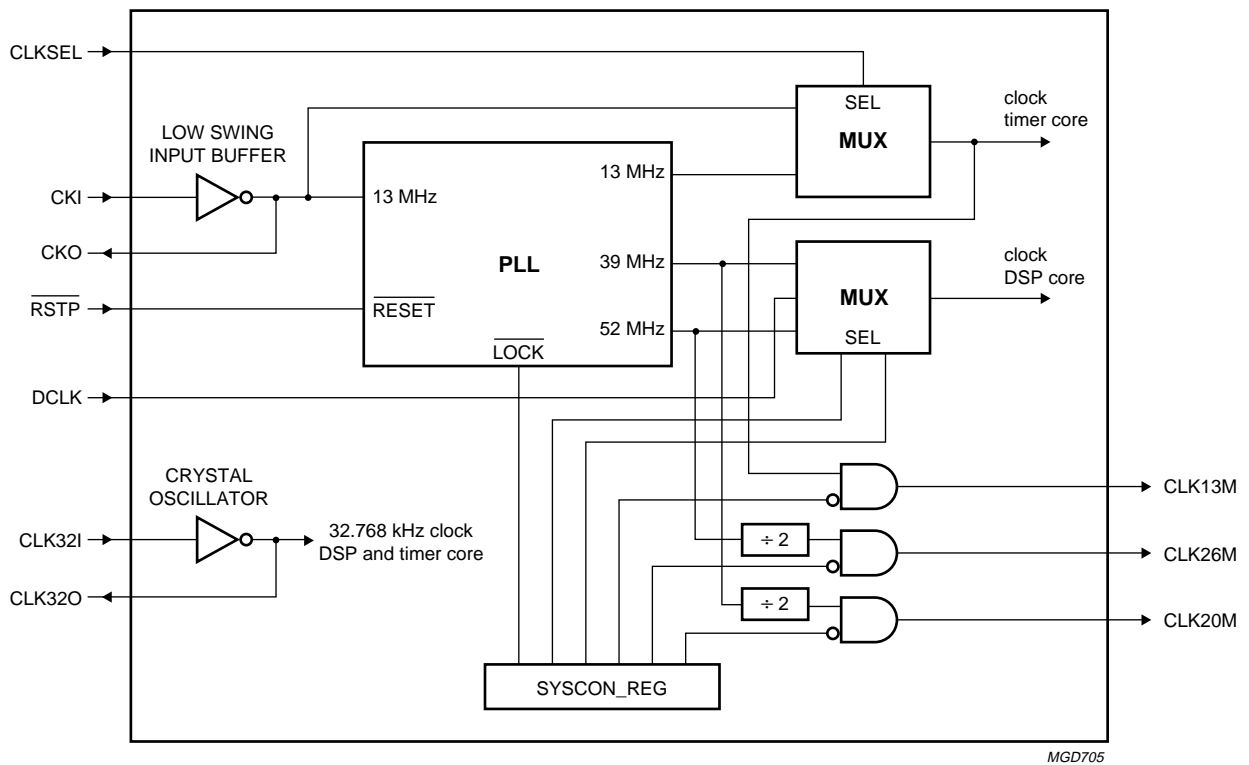

Fig.6 Clock generator block diagram.



## GSM signal processing IC

## PCF5083

## 8.2 ON/OFF Logic

The ON/OFF logic performs the main power on and off switching function for the whole mobile. The on/off conditions are controlled via an operators keyboard, a low voltage battery indication circuit, a hardware Watchdog Timer or an auxiliary switch on input for general purpose use.

The hardware control interrupt HWCTRL\_INT, signalled via the  $\overline{\text{COMB\_INT}}$  output (refer to Section 10.2), is used to signal the status of the ON/OFF Logic. The inputs DSPEN and TIMEN are used to control the Watchdog function.  $\overline{\text{RST}}$  and  $\overline{\text{RSTO}}$  are asynchronous reset lines. The inputs ONKEY, AUXON and  $\overline{\text{LOWVOLT}}$  are debounced with a time constant of 62.5 ms. The minimum pulse width for the safe detection of a signal transition is therefore  $2 \times 62.5 = 125$  ms on any of these lines. The ON/OFF Logic signals are specified in Table 4.

Table 4 ON/OFF Logic signals

SIGNAL	DESCRIPTION
ONKEY	Input (active HIGH) to be connected to the ON/OFF switch of the operators keyboard.
AUXON	Input (edge sensitive) for general purpose use, e.g. used as battery charger connect indication or ignition sense in mobile applications.
$\overline{\text{LOWVOLT}}$	Input (active LOW) to be connected to an external low battery indication circuit.
POWON	Output (active HIGH) to be connected to the ON terminal of the supply voltage switch.
NPOWON	Inverted output signal of POWON.

Table 5 Mobile switch-on conditions

$\overline{\text{RSTO}}$	$\overline{\text{LOWVOLT}}$	ONKEY	AUXON	ALARM TIME MATCHES CURRENT TIME	POWON	$\overline{\text{COMB\_INT}}$
L	X	X	X	X	L	3-state
H	L	X	X	X	L	3-state
H	H	L → H	X	X	L → H	H → L
H	H	X	L → H	X	L → H	H → L
H	H	X	X	yes	L → H	H → L

## 8.2.1 MOBILE SWITCH-ON PROCEDURE

Switching on the mobile is initiated via the PCF5083 according to Table 5.

If one of the three conditions ONKEY, AUXON or Alarm time match become true, a corresponding flag is set in register HWCTRL\_REG. As soon as one of these flags is set, signal POWON is set and NPOWON is reset. At the same time the HWCTRL\_INT interrupt is activated. The interrupt condition is signalled via the  $\overline{\text{COMB\_INT}}$  line to the System Controller if the relevant bit is set in the COMBINT\_REG register (refer to Section 10.2).

The hardware reset  $\overline{\text{RST}}$  clears the enable bits for the  $\overline{\text{COMB\_INT}}$  interrupt lines.

The interrupt flags in register HWCTRL\_REG must be cleared by the System Controller to deactivate the interrupt condition. A flag is cleared by writing a logic 1 to its bit location.

The POWON output is the main power control signal. As soon as POWON goes HIGH, all ICs in the mobile are powered via the supply voltage switch. The  $\overline{\text{LOWVOLT}}$  input asserted LOW, indicating a low voltage situation, or  $\overline{\text{RSTO}}$  asserted LOW inhibits the mobile to be switched on.

If the PCF5083 was switched on via AUXON (HWCTRL\_REG[AUXON\_LH] = 1) and the AUXON signal remains HIGH, the flag HWCTRL\_REG[AUXON\_LH] must be cleared, before the PCF5083 enters the Power-down mode.

## GSM signal processing IC

## PCF5083

## 8.2.2 MOBILE SWITCH-OFF PROCEDURE

The switch-off request to the System Controller is initiated via a LOW-to-HIGH transition and hold of pin  $\overline{\text{ONKEY}}$  for longer than 1 second or a LOW level on pin  $\overline{\text{LOWVOLT}}$ . The  $\text{HWCTRL\_INT}$  interrupt is activated if one of these conditions has set its corresponding flag in register  $\text{HWCTRL\_REG}$ .

The next step is to deactivate the POWON signal. Therefore the flag  $\text{HWCTRL\_REG}[\text{SWOFF}]$  has to be set. If the SWOFF flag is not set within 8 seconds (see Section 8.2.3) and the Watchdog Timer expires, POWON is deactivated without any further interaction. The SWOFF flag is automatically cleared when the mobile is switched on again.

The PCF5083 is immediately and under all conditions forced into the off state with  $\overline{\text{RSTO}}$  asserted LOW.

**Table 6** Mobile switch-off request conditions

$\overline{\text{ONKEY}}$	$\overline{\text{LOWVOLT}}$	$\overline{\text{COMB\_INT}}$
H	H	H
L → H	X	H → L
X	H → L	H → L

**Table 7** Mobile switch-off conditions

$\text{HWCTRL\_REG}[\text{SWOFF}]$	OFF/WATCHDOG TIMER EXPIRES	$\overline{\text{RSTO}}$	POWON
L	no	H	H
L → H	no	H	H → L
L	yes	H	H → L
X	X	L	H → L

It should be noted that:

- If POWON is LOW (switch-off state), all outputs of the PCF5083 except POWON and NPOWON are in their high-impedance state.
- The hardware control interrupt ( $\text{HWCTRL\_INT}$ ) is not asserted externally but stays internally pending during Sleep mode. The timing generator unit is forced into wake-up state if the hardware control interrupt is asserted internally.
- Other interrupt conditions, caused by the MMI power-down unit and the real time clock unit, are also indicated with the hardware control interrupt. These conditions are mentioned in the appropriate sections.
- The interrupt flags in register  $\text{HWCTRL\_REG}$  have to be cleared by the System Controller to deactivate the interrupt condition. A flag is cleared by writing a logic 1 to its bit location.

GSM signal processing IC

PCF5083

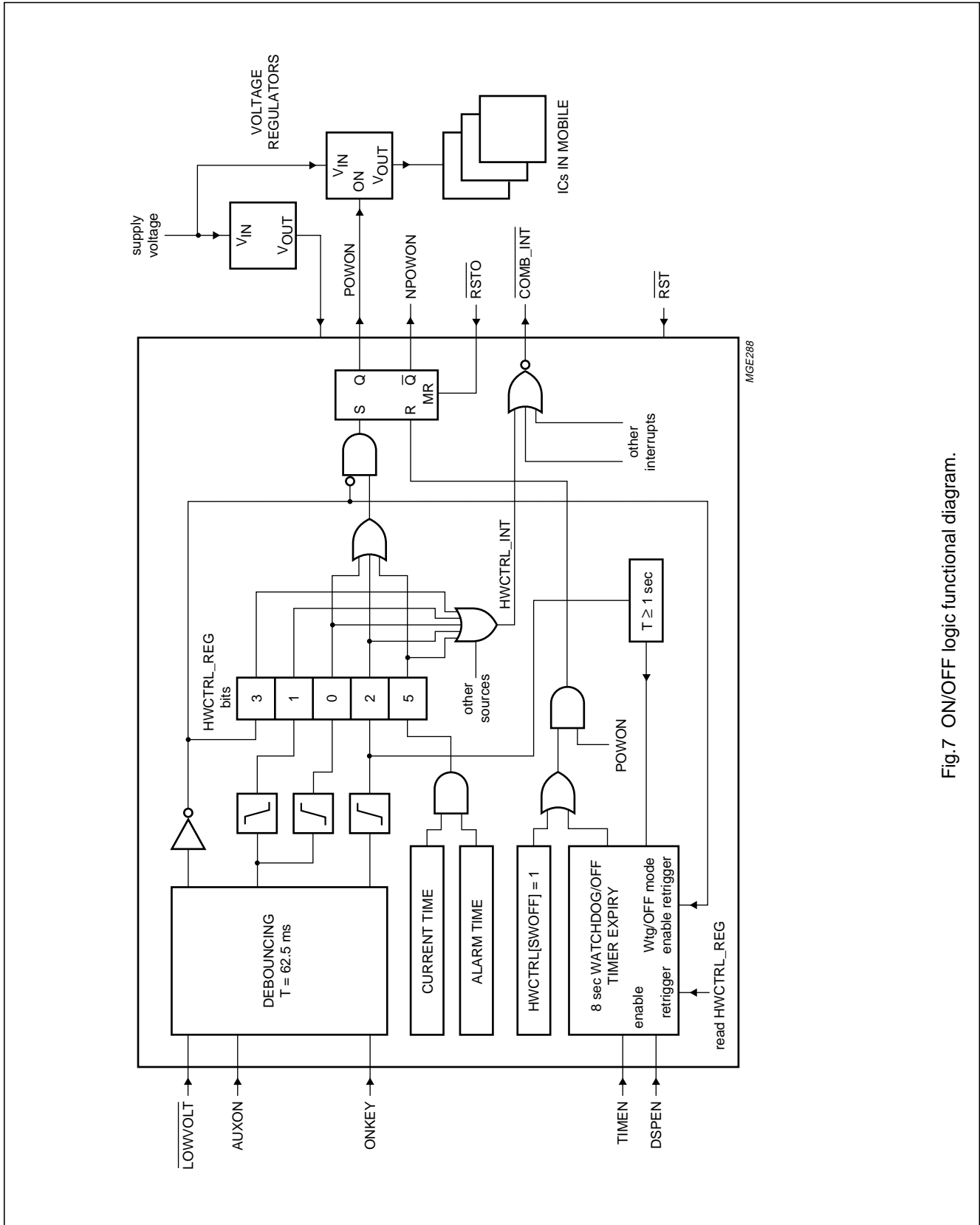

Fig.7 ON/OFF logic functional diagram.

## GSM signal processing IC

## PCF5083

### 8.2.3 OFF TIMER AND WATCHDOG TIMER

The hardware switch-off and Watchdog Timer are used to power-down the mobile if the System Controller has lost control for more than 8 seconds.

#### 8.2.3.1 Watchdog Timer

After the reset signal  $\overline{RST}$  is deactivated, the Watchdog Timer starts to count. If the timer expires after 8 seconds, the POWON output is set LOW. To prevent this occurring, the System Controller must restart the timer periodically, reading register HWCTRL\_REG within 8 seconds after the previous read operation. The Watchdog function is enabled if DSPEN = TIMEN = LOW. The configuration DSPEN = TIMEN = HIGH disables the Watchdog Timer. All other settings are for debugging purposes.

#### 8.2.3.2 OFF Timer

After the switch-off request (HWCTRL\_INT activated via  $\overline{LOWVOLT}$  or ONKEY conditions), the OFF-Timer starts to count. If the timer expires after 8 seconds, or if the System Controller sets HWCTRL\_REG[SWOFF] to a logic 1, the POWON output is set LOW. The OFF-Timer cannot be restarted with a read access to register HWCTRL\_REG.

For some special purposes, e.g. if the battery charging control is handled from the System Controller, the OFF-Timer can be stopped after it was activated from ONKEY or  $\overline{LOWVOLT}$ . It then resumes its watchdog function. The OFF-Timer is stopped with a write access to register STOP\_REG. The data value written to this register has to be A5H. Other data values do not stop the OFF-Timer.

It should be noted that:

- The OFF/Watchdog Timer is not restarted after a stop operation
- If either the ONKEY or  $\overline{LOWVOLT}$  line stays active after a stop operation, it is again recognized after its 1 second switch-off time-out or 62.5 ms debouncing period, respectively.

### 8.3 Timing Generator

The Timing Generator provides TDMA timing and power-down signals for the RF transmitter, RF receiver, synthesizer and baseband interface IC.

The Timing Generator has three modes of operation to control the mobile:

1. **Normal mode:** in this mode the mobile is fully active. All ICs receive their operating voltage, the power consumption is reduced by switching the ICs on and off with their power-down inputs.
2. **Sleep or Idle mode:** in this mode the mobile is switched on, but no call is active. The mobile will be fully activated if a mobile originated call is requested via the keyboard. Otherwise parts of the mobile are activated from time to time to monitor incoming calls. Outside these intervals all ICs can be switched off under control of the PCF5083. In this mode the main 13 MHz clock is switched off. To maintain TDMA timing alignment, the PCF5083 is running temporarily on a slower clock frequency.
3. **Reduced Sleep mode:** this mode is equal to the Sleep mode, except that the TDMA timing alignment is maintained by the main 13 MHz clock.

In this chapter the following definitions are used:

- 1 bit (Bit) =  $48 \times \frac{1}{13000000} \text{ s} = 3.692 \mu\text{s} \left( \frac{1}{1250} \text{ TDMA frame} \right)$
- 1 quarterbit (QB) =  $\frac{1}{4} \text{ Bit} = 0.923 \mu\text{s} \left( \frac{1}{5000} \text{ TDMA frame} \right)$
- 1 timeslot (TS) =  $625 \text{ QB} = 0.576 \text{ ms} \left( \frac{1}{8} \text{ TDMA frame} \right)$
- 1 Burst = 1 TS

The term frame refers to a TDMA frame throughout this section unless otherwise stated.

The Timing Generator consists of:

- The quarterbit counter (QBC) counting 5000 quarterbit steps in one TDMA frame and running on 1.0833 MHz. This clock is switched off during Sleep mode.
- The Timing Generator (TG) with output polarity and mask registers.
- The sleep quarterbit counter (SQBC).
- The Sleep mode timing generator.

## GSM signal processing IC

## PCF5083

### 8.3.1 THE QUARTERBIT COUNTER

The quarterbit counter (QBC) represents the timebase of the mobile. It consists of a 13-bit upcounter. The counter directly counts the quarterbit steps within one TDMA frame. Its range is therefore 0 to 4999.

At the beginning of every TDMA frame (quarterbit counter state 0) the signal  $\overline{\text{FRAME\_INT}}$  goes LOW, generating an interrupt (frame interrupt) to the System Controller. The interrupt line is deactivated by accessing the register `MODE0_REG`. The frame interrupt is disabled with `MODEx_REG[DISFRAMEINT] = 1`.

#### 8.3.1.1 Initial Quarterbit Counter Timing Alignment

The timing offset between a base station and a mobile station can be corrected by presetting the quarterbit counter with an estimated correction value. Therefore the register `QBC_REG` has to be set up with this correction value in frame N and the flag `QBRCTRL_REG[SYNC]` has to be set.

At the end of frame N the quarterbit counter is loaded from `QBC_REG` with zeros. The duration of frame N + 1 is  $5000 - [\text{QBC\_REG}]$  and the mobile will be synchronised at the beginning of frame N + 2. The frame interrupt at the beginning of frame N + 1 is disabled. The timing generation is disabled during frame N + 1. The SYNC flag is cleared after synchronization.

For the System Controller the resulting timing looks like frame N being extended and synchronization being achieved with frame N + 1.

#### 8.3.1.2 Maintaining the Quarterbit Counter Timing Alignment

Small timing corrections can be made by inserting or extracting one quarterbit step at the beginning of a TDMA frame. Therefore the `INSERT` or `EXTRACT` flag in register `QBCCTRL_REG` have to be set. These flags are cleared after the timing alignment was performed.

### 8.3.2 NORMAL MODE

In Normal mode the Timing Generator provides the output signals specified in Table 8.

The power-down signals `NPDTX2`, `NPDTX1` and `NPDBIAS` are active LOW by default. All other signals are active HIGH by default. Active HIGH in this context means that the signals are on high level during a receive or a transmit burst.

The output polarity can be changed by setting the corresponding bit in register `POL_REG` to a logic 1. The signals can be clamped to a level depending on their flag in `POL_REG` by setting the corresponding bit in register `MASK_REG` to a logic 0.

After a reset with  $\overline{\text{RST}}$ , the receiver, transmitter and synthesizer control lines are set to their inactive level.

The general MS timing is assumed to have the receive timeslot (RX) in timeslot 0, the transmit timeslot (TX) in timeslot 3 and the monitor timeslot (MON) in timeslot 6 within a TDMA frame.

**Table 8** Output signals

SIGNAL	DESCRIPTION
<b>Signals for the receiver section</b>	
RXON	baseband interface IC receiver enable
BEN	baseband interface IC enable
PDRX1	receiver power-down 1
PDRX2	receiver power-down 2
<b>Signals for the transmitter section</b>	
TXON	baseband interface IC transmitter enable
BEN	baseband interface IC enable
TXKEY1	power amplifier power-down
TXKEY2	power ramping controller trigger signal
PDTX1	transmitter power-down 1
NPDTX1	inverted output of PDTX1
NPDTX2	transmitter power-down 2
PDPIAS	power amplifier bias voltage power-down
NPDBIAS	inverted output of PDBIAS
<b>Signal for the synthesizer</b>	
PDSYN	synthesizer power-down

## GSM signal processing IC

## PCF5083

## 8.3.2.1 Receiver Timing

The Receiver Timing is characterized in Table 9. The start and duration times are defined by loading the mentioned registers.

**Table 9** Receiver Timing (note 1)

BURST TYPE SIGNAL	START (QB) <sup>(2)</sup>	DURATION (BIT)
<b>Rx burst<sup>(3)(4)</sup></b>		
RXON	$RXSTART\_REG + 929 = (0 \text{ to } 127) + 929$	$RXLENGTHx\_REG = (1 \text{ to } 255)$
BEN	$RXSTART\_REG + 928 = (0 \text{ to } 127) + 928$	$RXLENGTHx\_REG + 4 = (1 \text{ to } 255) + 4$
PDRX1 <sup>(5)</sup>	$RXSTART\_REG + 1024 - PDRX1\_REG \times 32 = (0 \text{ to } 127) + 1024 - (0 \text{ to } 31) \times 32$	to end of RXON
PDRX2	$RXSTART\_REG + 1024 - PDRX2\_REG \times 32 = (0 \text{ to } 127) + 1024 - (0 \text{ to } 31) \times 32$	to end of RXON
PDSYN	$RXSTART\_REG + 1024 - PDSYN\_REG \times 32 = (0 \text{ to } 127) + 1024 - (0 \text{ to } 31) \times 32$	to end of RXON
<b>MON burst<sup>(6)(7)(8)</sup></b>		
RXON	$MONSTART\_REG + 929 = (0 \text{ to } 4999) + 929$	$RXLENGTHx\_REG = (1 \text{ to } 255)$
BEN	$MONSTART\_REG + 928 = (0 \text{ to } 4999) + 928$	$RXLENGTHx\_REG + 4 = (1 \text{ to } 255) + 4$
PDRX1 <sup>(5)</sup>	$MONSTART\_REG + 1024 - PDRX1\_REG \times 32 = (0 \text{ to } 4999) + 1024 - (0 \text{ to } 31) \times 32$	to end of RXON
PDRX2	$MONSTART\_REG + 1024 - PDRX2\_REG \times 32 = (0 \text{ to } 4999) + 1024 - (0 \text{ to } 31) \times 32$	to end of RXON
PDSYN	$MONSTART\_REG + 1024 - PDSYN\_REG \times 32 = (0 \text{ to } 4999) + 1024 - (0 \text{ to } 31) \times 32$	to end of RXON

**Notes**

1. A minimum delay of 948 quarterbit periods must be programmed between the end of a monitor burst and the start of the next monitor burst, measured from the falling edge of RXON to the next rising edge of RXON.
2. If  $(MONSTART\_REG + 929) > 5000$  then the monitor burst ends in the next TDMA timeslot at  $(MONSTART\_REG + 929) - 5000$ .
3.  $MODEx\_REG[RECRX]$  enable the generation of Rx burst timing.
4.  $RXBURSTx\_REG$  ( $x = 0$  to  $2$ ) is selected with 2 flags in register  $MODEx\_REG$ .
5. PDRX1 is not activated during a monitor burst if the  $MODEx\_REG[RXCAL]$  flag is set.
6. For the three level measurement mode, a second monitor burst can be generated during the TX timeslot. The start position of this burst is then controlled with register  $TXSTART\_REG$ . Its duration is given from the same register as for the actual monitor burst.
7. If  $(MONSTART\_REG + 929 + RXBURSTx\_REG) > 5000$  then the monitor burst ends in the next TDMA timeslot at  $(MONSTART\_REG + 929 + RXBURSTx\_REG) - 5000$ .
8.  $MODEx\_REG[RECMON]$  enable/disable the generation of monitor burst timing.

GSM signal processing IC

PCF5083

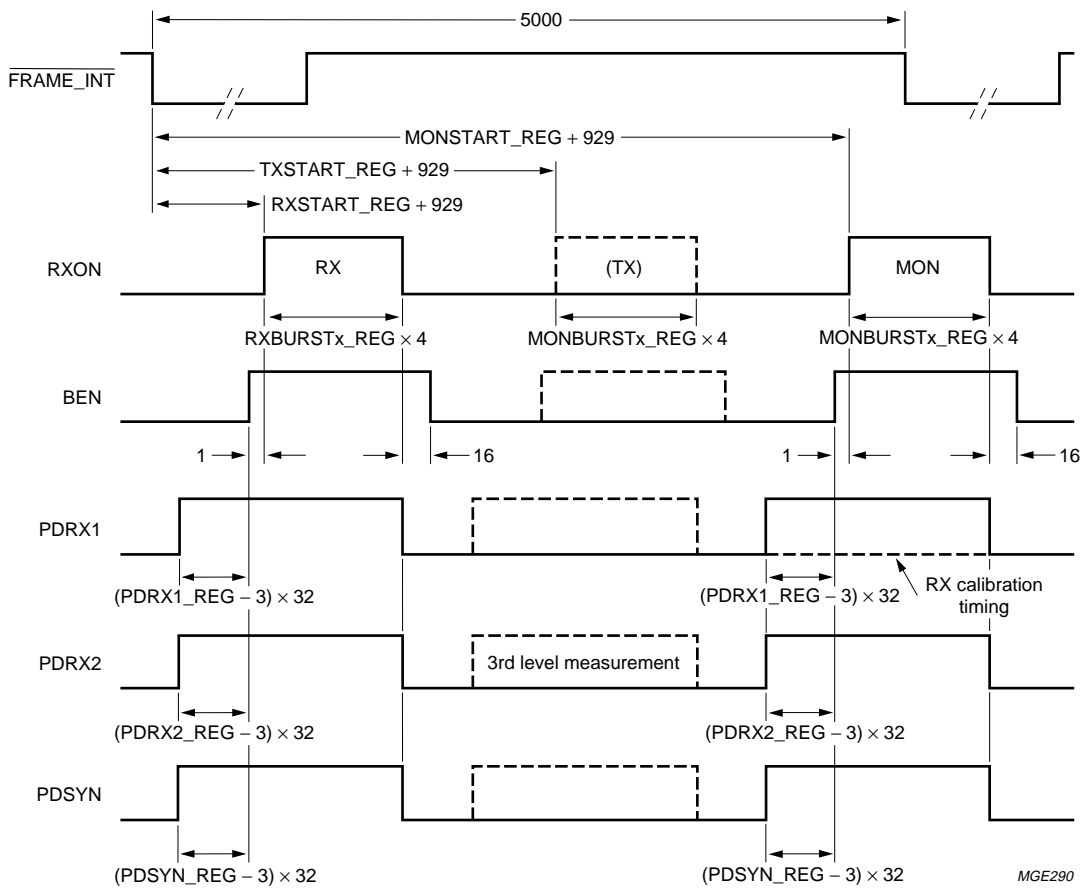

Fig.8 Receiver timing.

## GSM signal processing IC

PCF5083

## 8.3.2.2 Transmitter Timing

The transmitter timing is shown in Table 10. The start and duration times are defined by loading the named registers.

**Table 10** Transmitter Timing

BURST TYPE SIGNAL	START (QB) <sup>(1)</sup>	DURATION (QB) <sup>(2)</sup>
<b>TX burst</b>		
TXON	TXSTART_REG + 929 = (0 to 2047) + 929	TXLENGTHx_REG = (1 to 255)
BEN	TXSTART_REG + 928 = (0 to 2047) + 928	to end of TXON + 16
(N)PDTX1,2	TXSTART_REG + 1024 – PDRX1,2_REG × 32 = (0 to 2047) + 1024 – (0 to 31) × 32	to end of TXKEY + PDDELAY_REG (1 to 63)
(N)PDBIAS	TXSTART_REG + 1024 – PDBIAS_REG × 32 = (0 to 2047) + 1024 – (0 to 31) × 32 or if PDBIAS_REG < PDTX1_REG + 4 (note 3): TXSTART_REG + 1024 – (PDTX1_REG + 4) × 32 = (0 to 2047) + 1024 – (0 to 31) × 32	to end of TXKEY + PDDELAY_REG + 32 (1 to 63)
TXKEY1	TXSTART_REG + 929 + KEYON1_REG = (0 to 2047) + 929 + (1 to 511) × 32	TXKEYx_REG = (1 to 1023)
TXKEY2	TXSTART_REG + 929 + KEYON2_REG = (0 to 2047) + 929 + (1 to 511) × 32	to end of TXKEYx + KEYOFF_REG (1 to 63)
PDSYN	TXSTART_REG + 1024 – PDSYN_REG × 32 = (0 to 2047) + 1024 – (1 to 31) × 32	to end of TXKEYx + PDDELAY_REG (1 to 63)

**Notes**

1. The timing advance is adjusted with the value of TXSTART\_REG.
2. TXBURSTx\_REG and TXKEYx\_REG (x = 0 or 1) is selected with a flag in register MODEx\_REG.
3. Therefore (N)PDBIAS will always be active at least 4 × 32 QB prior to PDTX1.



GSM signal processing IC

PCF5083

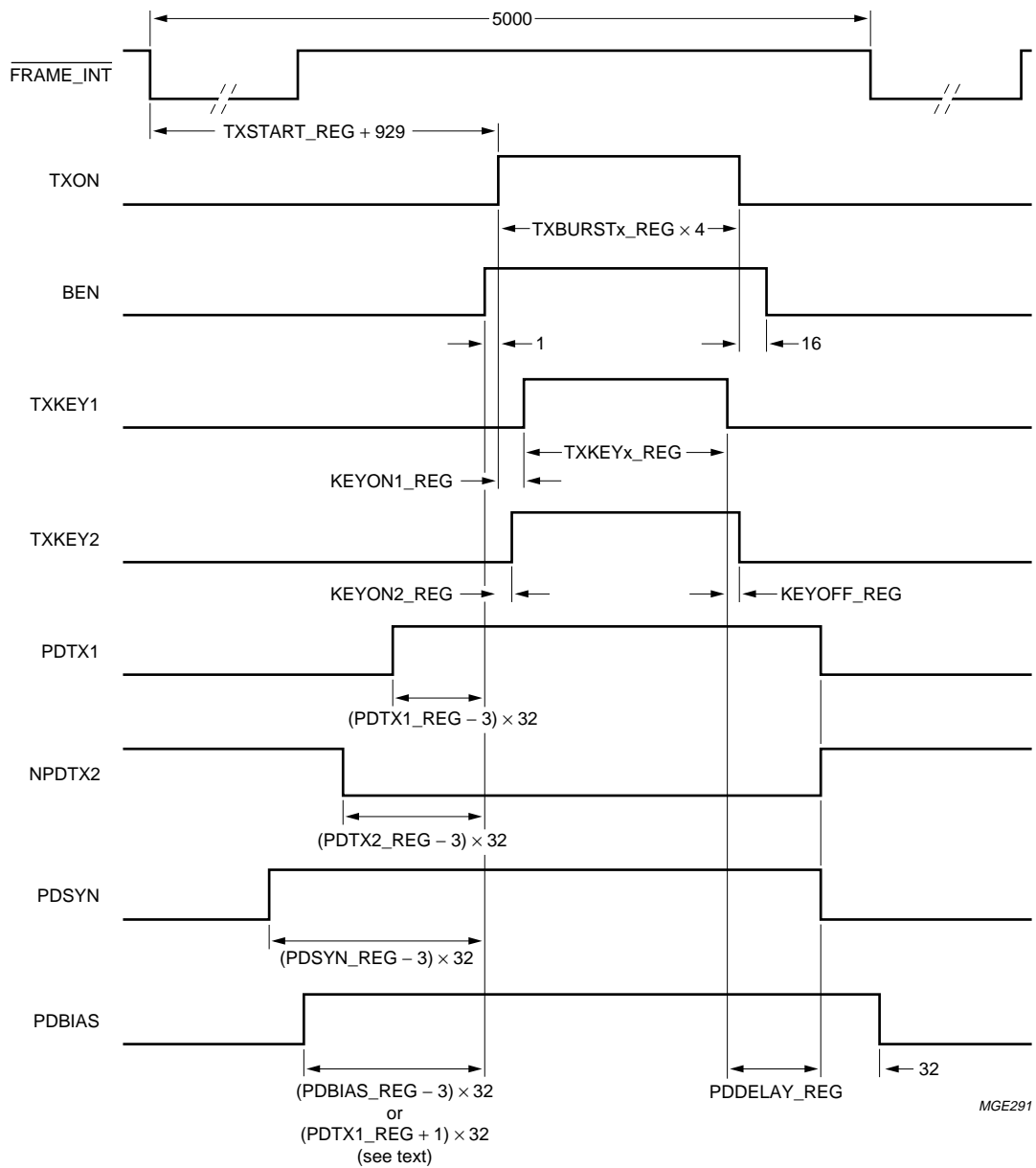

Fig.9 Transmit burst timing.

## GSM signal processing IC

## PCF5083

## 8.3.2.3 Timing Generation

To generate all burst types required to fulfil the GSM timing, it is necessary to combine and/or modify the basic receive and transmit burst sequences. For this purpose two registers MODE0\_REG and MODE1\_REG exist, containing some flags to control the burst timing. Both mode registers and the registers RXSTART\_REG, TXSTART\_REG and MONSTART\_REG have an additional pipeline stage. The first register stage can be read or written by the SC.

The second stage is used for timing generation. The pipelining operation is performed at QBC = 0 (together with the frame interrupt generation). Some flags inside the mode registers have a third pipelining stage to allow the generation of a MON burst which overlaps into the next frame. The System Controller must set up the registers within the frame before the programmed timing becomes active. Which register MODE0\_REG or MODE1\_REG is actually used is described in Table 11. MODE0\_REG and MODE1\_REG contain identical flags.

**Table 11** Mode Registers (MODE0\_REG and MODE1\_REG)

BIT	FLAG	DESCRIPTION
13	USEMODE	<b>MODE_REGx select.</b> If USERMODE = 0; then switch to MODE_REG0 after the next frame. If USERMODE = 1; then switch to MODE_REG1 after the next frame.
12	DISFRAGMENT	<b>Disable frame interrupt.</b> If DISFRAGMENT = 1; then the frame interrupt is disabled.
11	RXCAL	<b>RX calibration timing.</b> If RXCAL = 1; then the RX calibration timing is generated.
10	TXLENGTH	<b>Register select.</b> The state of this bit determines which registers are used for the TX burst. If TXLENGTH = 0; then registers TXBURST0_REG and TXKEY0_REG are used. If TXLENGTH = 1; then registers TXBURST1_REG and TXKEY1_REG are used.
9	MONLENGTH1	<b>RXBURSTx_REG select.</b> The state of these two bits determine which RXBURST register is used for the MON burst; see Table 12.
8	MONLENGTH0	
7	RXLENGTH1	<b>RXBURSTx_REG select.</b> The state of these two bits determine which RXBURST register is used for the Rx burst; see Table 13.
6	RXLENGTH0	
5	DTX	<b>DTX timing enable.</b> If DTX = 1; then DTX timing is enabled.
4	SEND	<b>TX burst timing.</b> If SEND = 1; the TX burst timing is generated.
3	RECON	<b>Receiver start-up.</b> If RECON = 1, the receiver start-up sequence for the MON burst in the idle frame is generated.
2	RECMON	<b>MON burst timing.</b> If RECMON = 1; the MON burst timing is generated.
1	RECTX	<b>Third level measurement.</b> If RECTX = 1; then the MON burst timing during the TX timeslot for a third level measurements generated.
0	RECRX	<b>Rx burst timing.</b> If RECRX = 1; the Rx burst timing is generated.

**Table 12** Register selection for the MON burst

MONLENGTH1	MONLENGTH0	REGISTER SELECTED
0	0	RXBURST0_REG is used.
0	1	RXBURST1_REG is used.
1	0	RXBURST2_REG is used.
1	1	Undefined during a MON burst.

## GSM signal processing IC

## PCF5083

**Table 13** Register selection for the Rx burst

RXLENGTH1	RXLENGTH0	REGISTER SELECTED
0	0	RXBURST0_REG is used.
0	1	RXBURST1_REG is used.
1	0	RXBURST2_REG is used.
1	1	Undefined during a RX burst.

**8.3.2.4** *MON burst during idle frame*

This burst is a special case of the MON burst. It is used for FCB search and for monitoring during the idle frame. If RECON is set, a timing equivalent to the MON burst timing is generated, with the exception that all output lines (BEN, RXON, PDRXx etc.) are kept active at the end of the burst. The output lines are set inactive again during the first frame with RECMON set at the time, they normally would be deactivated at the end of a MON burst. During the frames in between, either RECON = 1, or RECRX = RECTX = RECMON = RECON = SEND = 0 must be programmed.

**8.3.2.5** *Register mode switching*

Which of the registers MODE0\_REG or MODE1\_REG is used for timing generation is determined using the following two rules:

1. After any write access to MODE0\_REG, MODE0\_REG is active during the next frame.
2. After every frame the USEMODE flag of the currently active register determines which register is used during the next frame, unless there was a write access to MODE0\_REG during the current frame.  
e.g. MODE0\_REG: USEMODE = 1 and MODE1\_REG: USEMODE = 0 is programmed during frame N.

This causes the following timing:

- a) MODE0\_REG is active during frame N + 1
- b) MODE1\_REG is active during frame N + 2
- c) MODE0\_REG is active during frame N + 3 and so on, until MODE0\_REG is being written again.

**8.3.2.6** *DTX Mode Processing*

DTX mode (Discontinuous Transmission) is enabled with MODE<sub>x</sub>\_REG[DTX] = 1. In DTX mode, the DSP makes the decision whether a TX burst should be generated or not. The DTX condition is signalled via IO4 (generate transmit burst: IO4 = 0, no transmit burst: IO4 = 1). If no TX burst is to be generated, the power-down lines TXKEY1/2, (N)PDTX1/2 and PDSYN are kept inactive or if already asserted, they are set inactive again. (N)PDBIAS become inactive with their default delay of 8 bit after (N)PDTX1/2 respective PDSYN if they were already asserted, otherwise they also remain inactive. TXON and BEN are not affected from DTX mode.

**8.3.2.7** *Interface to the RF-IC Bus*

The Timing Generator provides trigger signals for the frequency and gain control channels of the RF-IC interface when the quarterbit counter matches either RXSTART\_REG, TXSTART\_REG or MONSTART\_REG. Further trigger signals are generated for the gain control channel after every receive burst to send the contents of register DACOFF\_REG and prior to a receive burst if the quarterbit counter matches xxSTART\_REG + 1024 – AGCSTART\_REG × 32 (xx = RX, TX or MON) to send the contents of register DACON\_REG (refer to Section 8.4).

Note, if the generation of a trigger signal falls into an active burst, the trigger signal is delayed until the end of the current burst.

## GSM signal processing IC

PCF5083

## 8.3.2.8 Timing modes Application Examples

Table 14 Timing mode applications

FRAME	4	3	2	1	0	BIT ASSIGNMENT; REGISTER MODE_REG
	SEND	RECON	RECMON	RECTX	RECRX	ACTION
N	0	1	0	0	0	<b>BCCH Detection</b> Receiver on at the start of timeslot 0 (MONSTART_REG = 0) in TDMA frame N + 1. Receiver on.
N + 1 to N + M	0	0	0	0	0	Keep receiver on.
N + 1 + M	0	0	1	0	0	Receiver off after number of samples defined by MONSTART_REG, RXLENGTHx_REG and number of TDMA frames M.
X	0	0	0	0	1	<b>Frequency Estimation</b> Receive during TS0.
X	1	0	1	0	1	<b>Frame with RX, TX, MON</b> Receive during RX, MON, transmit during TX.
I-1	1	1	0	0	1	<b>Frame before idle frame (monitoring)</b> Receive during RX, transmit during TX, receiver on defined by MONSTART_REG.
I	0	0	1	0	0	<b>Idle frame (monitoring)</b> Receiver off defined by MONSTART_REG and RXLENGTHx_REG.
I-1 or <sup>(1)</sup>	1	0	1	0	1	<b>Frame with RX, TX, MON</b> Receive during RX, MON, transmit during T.
I-1	1	0	0	0	1	Receive during RX, transmit during TX.
I or <sup>(1)</sup>	0	0	0	0	0	<b>Idle frame (SYNC burst reading)</b> No operation.
I	0	0	1	0	0	Receive during MON.
X	0	0	1	1	1	<b>Three level measurements</b> Receive during RX, TX and MON slot.
X	1	0	0	0	0	<b>Send access burst</b> Transmit during TX.

**Note**

1. The SYNC burst location is defined by MONSTART\_REG. If a timing is required with  $s = \text{MONSTART\_REG} \geq 5000$ , MONSTART\_REG is programmed with  $s \bmod 5000$  and the second alternative is used.

## GSM signal processing IC

## PCF5083

During the three level measurement mode the burst length of the receive burst during the TX slot is defined by the same register RXBURSTx\_REG as used for the MON burst. The receive frequency must be set by programming the TX channel of the RF\_IC interface.

For a certain operation mode in frame N, the Timing Generator has to be programmed with all necessary parameters in frame N – 1. For this purpose the registers RXSTART\_REG, TXSTART\_REG, MONSTART\_REG and MODEx\_REG have an additional pipelining stage. The pipelining takes place at the beginning of every TDMA frame with the frame interrupt generation.

### 8.3.3 SLEEP MODE

The Sleep mode circuitry is used to reduce the power consumption during the Idle mode. During Sleep mode, the mobile is switched on, but no call is active. The mobile is only activated to read the paging blocks and for neighbour cell monitoring. Outside these intervals, all ICs can be switched off to save power.

In this mode also the main 13 MHz oscillator may be switched off. To maintain TDMA timing alignment, the PCF5083 is running temporarily on a slower clock frequency, derived from the 32.768 kHz real time clock oscillator. This clock is called Sleep Clock (SLCLK). During the Sleep mode the PCF5083 controls the signals specified in Table 15, the timing for these signals is detailed in Table 16.

Sleep mode is activated with QBCCTRL\_REG[SLEEP] = 1 and QBCCTRL\_REG[SLEEPRED] = 0 (the SLEEPRED flag is used for reduced Sleep mode, see below). The register SLEEPCNT\_REG has to be programmed with the number of TDMA frames the mobile wants to sleep minus one. Register FRAMECNT\_REG is automatically cleared when the Sleep mode is entered and counts the number of TDMA frames actually slept. The 9-bit registers SLEEPCNT\_REG and FRAMECNT\_REG allow a maximum Sleep mode period of 512 frames. Refer to Fig.11 for the signal flow.

**Table 15** Signals controlled by the PCF5083 during Sleep mode

SIGNAL	DESCRIPTION
REFON	Reference oscillator on. Active HIGH output.
NREFON	Inverted REFON output.
DSPON	DSP power-down (connected on chip).
GPON1	General purpose power-down and radio part interface 3-state enable. Active HIGH output.
GPON2	General purpose power-down. Active HIGH output.

**Table 16** Sleep mode signal timing

SIGNAL	FRAME NUMBER	ACTIVATION OF SIGNAL IF SLEEPCNT_REG EQUALS
(N)REFON	In frame N + 1 on the third positive SLCLK edge	REFON_REG (notes 1 and 2)
DSPON	In frame N + 1 on the second positive SLCLK edge	KISSON_REG (note 2)
GPON1	In frame N + 1 on the second positive SLCLK edge	GPON1_REG (note 2)
GPON2	In frame N + 1 on the third positive SLCLK edge	GPON2_REG (note 2)

#### Notes

- (N)REFON is not deactivated if the Sleep mode is initiated while the sleep clock calibration procedure is running (see Section 8.3.3.3), while the IOM<sup>®</sup>-2 interface is enabled or the MMICLK flag in register HWCTRL\_REG is set, indicating that the MMI controller requires the 13 MHz clock.
- Maximum 295 ms before Sleep mode terminates with 4.6 ms resolution  $\{(0 \text{ to } 63) + 1\} \times 4.6 \text{ ms}$ .

GSM signal processing IC

PCF5083

A power-down line is only deactivated during Sleep mode if the corresponding activation register is programmed with a higher value than register SLEEP\_CNT\_REG. Otherwise the power-down line stays active during Sleep mode. The output polarity of the power-down lines can be changed by setting their corresponding bit in register POL\_REG to a logic 1. The signals can be clamped to a level depending on their flag in POL\_REG by setting the corresponding bit in register MASK\_REG to a logic 0.

Because the 13 MHz clock is also internally disabled during Sleep mode, the PCF5083 cannot be accessed with the host port.

During Sleep mode, burst timing and frame interrupt generation is stopped and the registers MODE0\_REG and MODE1\_REG are cleared.

8.3.3.1 Transceiver control lines

The timing generator signals RXON, TXON, BEN, PDRX1, PDRX2, PDTX1, NPDTX1, NPDTX2, PDBIAS, NPDBIAS, PDSYN, TXKEY1, TXKEY2 and the RF device control bus signals RFCLK, RFDO, RFEN1 to RFEN4, RFE and the Voice Port signals ASF, ACLK and ADO are 3-stated as long as the signal GPON1 is inactive during Sleep mode.

The signals are driven into their high-impedance state independently of the actual polarity to which GPON1 is programmed, unless MASK\_REG[GPON1] = 0. In this case the outputs are driven during Sleep mode.

8.3.3.2 The Sleep Quarterbit Counter

In Sleep mode, the 13 MHz reference oscillator is switched off to reduce the power consumption. The TDMA timing is maintained using the sleep quarterbit counter (SQBC), which is driven from the sleep clock (SLCLK). The sleep clock is derived from the 32.768 kHz real time clock. Upon entering Sleep mode, the contents of the quarterbit counter are copied to the sleep quarterbit counter. After the end of a Sleep mode period, the sleep quarterbit counter is copied back to the quarterbit counter and normal timing is performed again.

To maintain the correct timing over hundreds of TDMA frames, the sleep quarterbit counter is incremented with the value SQBC\_INC equal to the clock ratio between the quarterbit clock and the sleep clock. This value must be very accurate and can be derived using the calibration method described in Section 8.3.3.3.

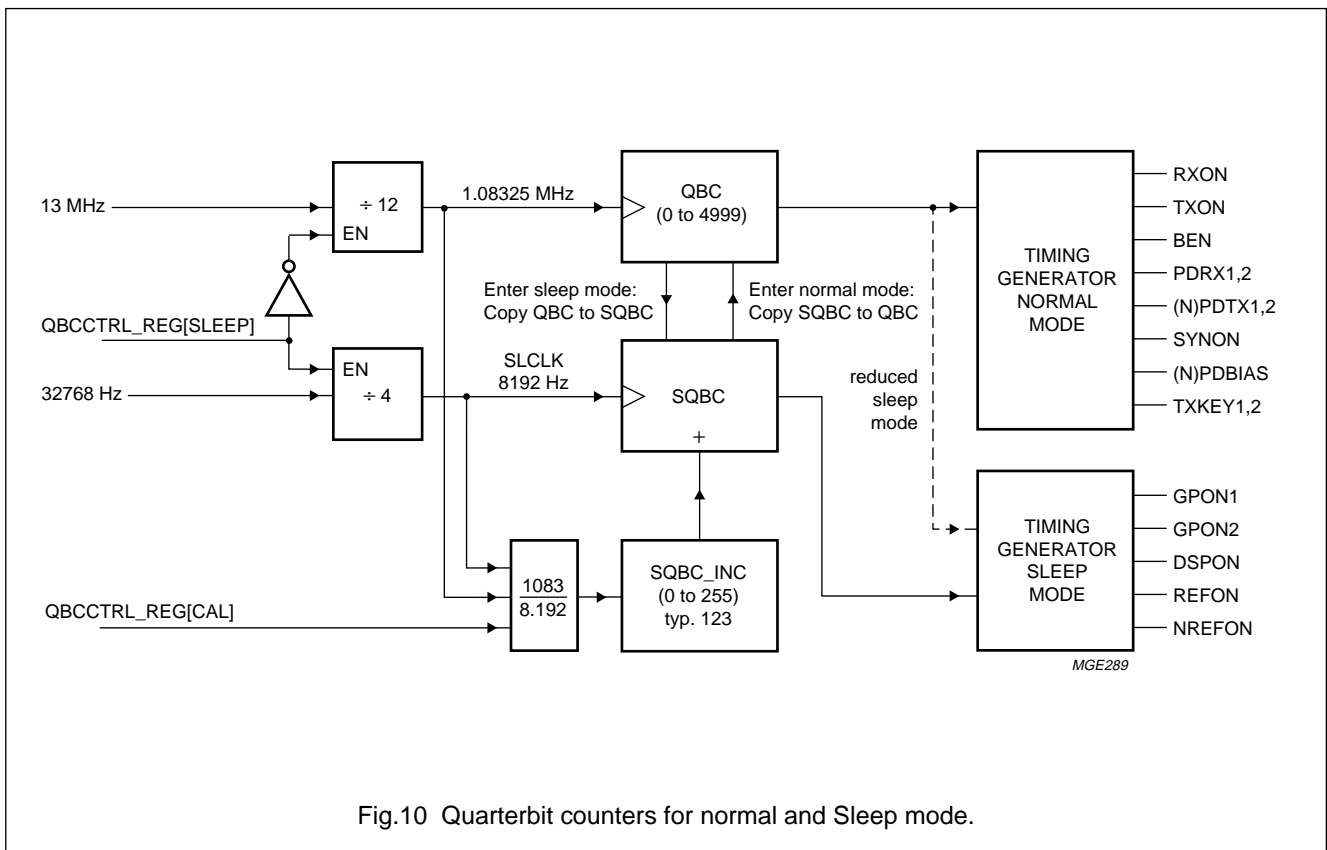

Fig.10 Quarterbit counters for normal and Sleep mode.

## GSM signal processing IC

## PCF5083

*8.3.3.3 Sleep Clock Calibration*

Since the ratio between the quarterbit clock and the sleep clock may vary, an accurate value for the increment SQBC\_INC can be obtained with the following procedure:

1. Set QBCCTRL\_REG[*CAL*] = 1 to enable the calibration mode.
2. The calibration procedure lasts for 8 seconds.
3. After calibration, the *CAL* flag in QBCCTRL\_REG is automatically cleared. After 1 ms the register SQBCINC\_REG holds the lower 8 bits of the increment value and can be used to verify the calibration process. The maximum allowed frequency deviation is -23.8 kHz to +25.4 kHz at 13 MHz and -63.6 Hz to +60.3 Hz at 32.768 kHz.

During the calibration procedure, the 13 MHz master clock may not be switched off. Therefore, REFON stays active even if the Sleep mode is enabled.

The calibration procedure has to be repeated from time to time, because the exact frequency of the 13 MHz as well as the 32 kHz clock may change.

After power up, the calibration procedure must be performed before the Sleep mode can be activated.

*8.3.3.4 Reduced Sleep mode*

During reduced Sleep mode the mobile timing is maintained with the quarterbit counter. The sleep quarterbit counter is not used. For the System Controller all timings are as in Sleep mode. The signal REFON is always active. All other Sleep mode signals (GPON1 etc.) are activated as during Sleep mode. The reduced Sleep mode is invoked with QBCCTRL\_REG[*SLEEP*] = 1 and QBCCTRL\_REG[*SLEEPRED*] = 1.

*8.3.3.5 From Sleep mode to Normal mode*

The PCF5083 is forced into a wake-up state if the hardware control interrupt HWCTRL\_INT is asserted internally (caused by the ON/OFF monitor, MMI power-down unit or real time clock). The interrupt line COMB\_INT is not asserted but the interrupt stays pending internally until Sleep mode is finished.

If the PCF5083 enters the wake-up state and SLEPCNT\_REG is less than or equal to REFON\_REG, the Sleep mode terminates normally. Otherwise, if SLEPCNT\_REG is greater than REFON\_REG, REFON\_REG is copied to SLEPCNT\_REG instead of SLEPCNT\_REG being decremented at the next frame boundary and the Sleep mode terminates with reduced duration. The maximum delay from any wake-up request to the end of the wake-up procedure depends on the setting of REFON\_REG and is  $64 \times 4.6 \text{ ms} = 294.4 \text{ ms}$ .

After entering the normal mode again FRAMECNT\_REG shows the number of actually slept frames. If the Sleep mode terminated normally, this number equals the number SLEPCNT\_REG previously was programmed with.

The System Controller now has to set up the timing generator mode for the next frame. With the beginning of the next frame the PCF5083 enters the normal operation again.

GSM signal processing IC

PCF5083

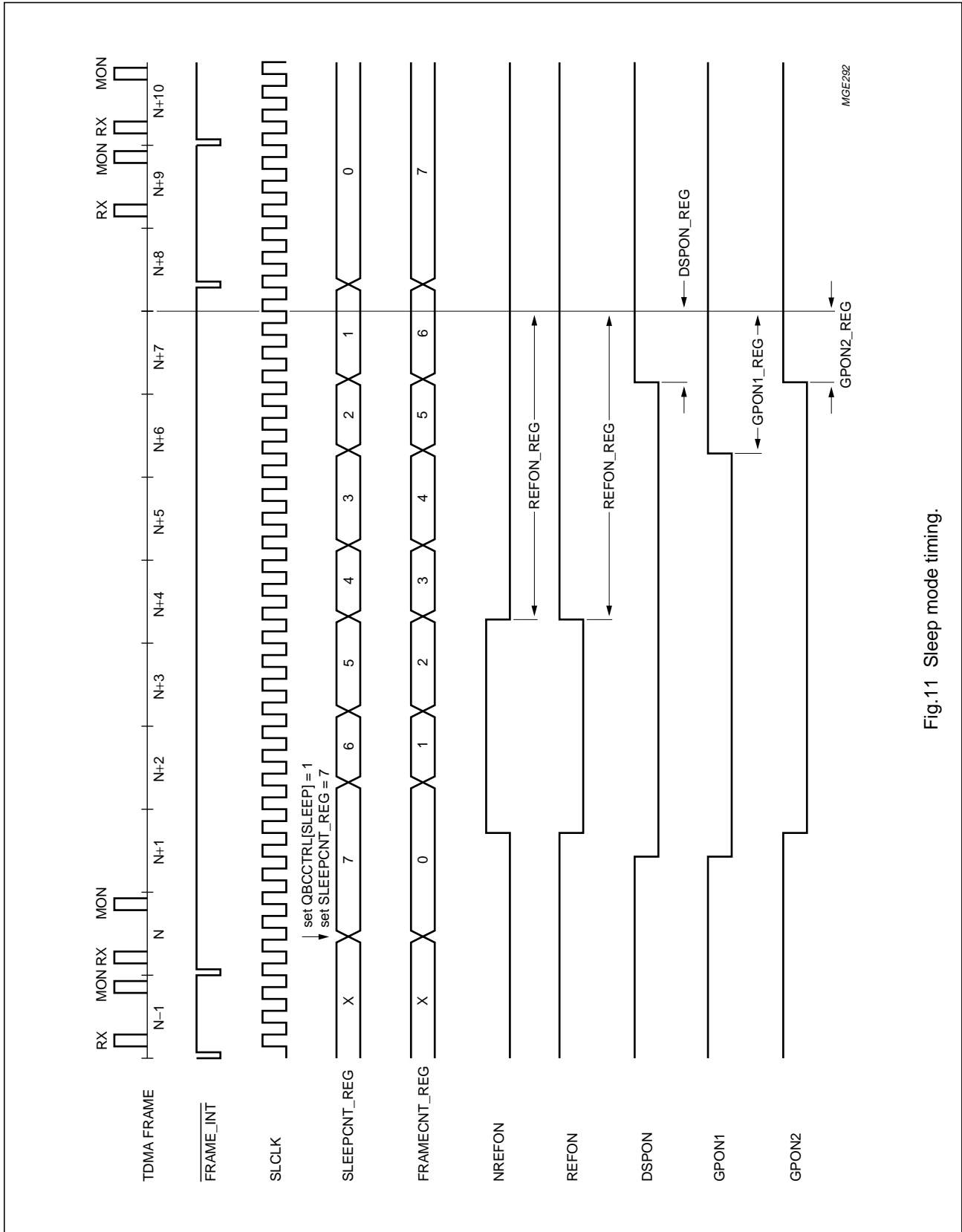

Fig.11 Sleep mode timing.



## GSM signal processing IC

## PCF5083

### 8.4 RF-IC Interface Bus

This block provides a serial interface to control the RF devices like synthesizer, baseband interface IC etc. The interface is upward compatible with the 'Philips Three Wire Bus'. Compared with the Philips bus it is extended for bidirectional data transfer and additional timing modes are implemented. The interface consists of a clock (RFCLK), a data output (RFDO), a data input (RFDI) and enable lines (RFEN1 to RFEN4 and RFE). The interface is subdivided into three logical channels as described below.

#### 8.4.1 FREQUENCY SETTING CHANNEL

The registers RX\_REG, TX\_REG and MON\_REG are set up during frame N – 1 with the frequency information for the RX, TX or MON burst of frame N. Therefore these three registers have a pipeline stage. The pipelining takes place at the beginning of every TDMA frame together with the frame interrupt generation. The transmission of the three registers is controlled from the timing generator as described in Section 8.3.2.7. The register TX\_REG is also used for a monitor burst during the TX timeslot. The register RFCTRL0\_REG contains four address bits (A0 to A3) which are transmitted with either of the three data registers. The data structure and the function of the mode (M0 to M2) and select (SEL0, SEL1) flags contained in RFCTRL0\_REG is described in Section 8.4.4.

#### 8.4.2 GAIN CONTROL CHANNEL

The registers RXGAIN\_REG, TXGAIN\_REG and MONGAIN\_REG are set up during frame N – 1 with the gain control information for the RX burst or MON burst of frame N. Therefore these three registers have a pipeline stage. The pipelining takes place at the beginning of every TDMA frame together with the frame interrupt generation. The transmission of the three registers is controlled from the timing generator as described in Section 8.3.2.7. No gain information is sent prior to a TX-burst. The register TXGAIN\_REG is used for a monitor burst during the TX timeslot. The DAC bit of these registers is not transmitted but used to select between the registers DAC0\_REG and DAC1\_REG. The register RFCTRL1\_REG contains four address bits (A0 to A3) which are transmitted with either of the three data registers. The data structure and the function of the mode (M0 to M2) and select (SEL0 and SEL1) flags contained in RFCTRL1\_REG is described in Section 8.4.4.

The DAC flag in xxGAIN\_REG selects either DAC0\_REG or DAC1\_REG to be transmitted immediately after xxGAIN\_REG. These two registers hold static data and do not have an additional frame pipeline stage like the xx\_REG or xxGAIN\_REG. The contents of register RFCTRL2\_REG functionally corresponds to the contents of RFCTRL1\_REG.

Two further registers, DACON\_REG and DACOFF\_REG exist. They are used to power-up or power-down a gain setting DAC. These two registers also hold static data like DACx\_REG. The transmission of the three registers is controlled from the timing generator as described in Section 8.3.2.7. The contents of RFCTRL3\_REG register functionally corresponds to the contents of RFCTRL1\_REG or RFCTRL2\_REG.

The MSB (bit 16) of the registers DAC0\_REG, DAC1\_REG, DACON\_REG and DACOFF\_REG is located in register MSB\_REG, because of the limited address space.

#### 8.4.3 IMMEDIATE CONTROL CHANNEL

The Immediate Control Channel (IMC) consists of the registers IMCOUT\_REG for the output direction and IMCIN\_REG for the input direction. The contents of IMCOUT\_REG are transmitted every time a new data word is written to it. The flag SIINT\_REG[IMC\_OBE] is set after the contents of IMCOUT\_REG was copied to the shift register. If the corresponding mask flag SIMASK\_REG[IMC\_OBE\_MASK] is set, the serial interface interrupt SI\_INT is activated. Together with IMCOUT\_REG being transmitted, the data at RFDI is read into register IMCIN\_REG. The flag SIINT\_REG[IMC\_IBF] is set at the end of the shift operation. The interrupt handling corresponds to the IMC\_OBE flag. The interrupt flags are cleared when their corresponding register is written respectively read.

The mode flags in IMCOUT\_REG have the same function as the flags in RFCTRLx\_REG. The four select flags (SEL0 to SEL3) correspond to the enable lines RFEN1 to RFEN4. Each enable line is activated if their corresponding select flag is set. Therefore it is possible to activate more than one line at a time.

## GSM signal processing IC

## PCF5083

**Table 17** Select flags in register IMCOUT\_REG

SEL0	SEL1	SEL2	SEL3	ACTIVE ENABLE LINE
1	X	X	X	RFSEN1
X	1	X	X	RFSEN2
X	x	1	X	RFSEN3
X	X	X	1	RFSEN4

The inhibit flag (INH) in IMCOUT\_REG controls whether the IMC operation is inhibited during a receive or transmit burst indicated with PDRX2 or NPDTX2 active. If the INH flag is set the IMC operation is delayed until PDRX2 and NPDTX2 become inactive. If the INH flag is reset the two lines are don't care.

## 8.4.4 OPERATION MODES AND CONTROL REGISTERS

The characteristics of each channel are controlled using the contents of the registers RFCTRL0\_REG to RFCTRL3\_REG.

The interface is programmable, one of three timing modes can be selected for every data transfer. For the exact timing see Chapter 16. In Mode 3 the transmission of the data registers associated with the control register is disabled.

If there is a conflict between the different data channels, data transmission is scheduled according to Table 22.

**Table 18** RC-IF Interface Bus Control Registers

BIT	FLAG	OPERATION
7	M1	These two bits select the timing mode, see Table 19.
6	M0	
5	SEL1	These two bits are used to assert the enable lines RFEN1 to RFEN4, see Table 21.
4	SEL0	
3	A3	These four bits form the address field.
2	A2	
1	A1	
0	A0	

**Table 19** Selection of the RC-IF Interface timing modes

MODE	M1	M0	BITS TRANSFERRED	RFE ASSERTED
0	0	0	21	no
1	0	1	21	no
2	1	0	16	yes
3	1	1	Transmission of the corresponding data registers is disabled.	

**Note**

- The 16 or 21 data bits are transmitted MSB first according to Table 20.

**Table 20** RF-IC Interface data structure

MODE	BITS TRANSFERRED	1ST BIT	LAST BIT
0 and 1	21 <sup>(1)</sup>	D17	A0
IMC channel	21	D20	D0
2	16	D15	D0

**Note**

- The 21 bits consist of D17 to D0 and A2 to A0.

**Table 21** Selection of enable lines RFEN1 to RFEN4

SEL1	SEL0	ENABLE LINE ASSERTED
0	0	RFEN1
0	1	RFEN2
1	0	RFEN3
1	1	RFEN4

**Table 22** Order of priority

PRIORITY	TRANSMISSION
Highest	frequency setting
	gain control DACOFF_REG
	gain control DACON_REG
	gain control xxGAIN_REG then DACx_REG
Lowest	Immediate Control Channel

GSM signal processing IC

PCF5083

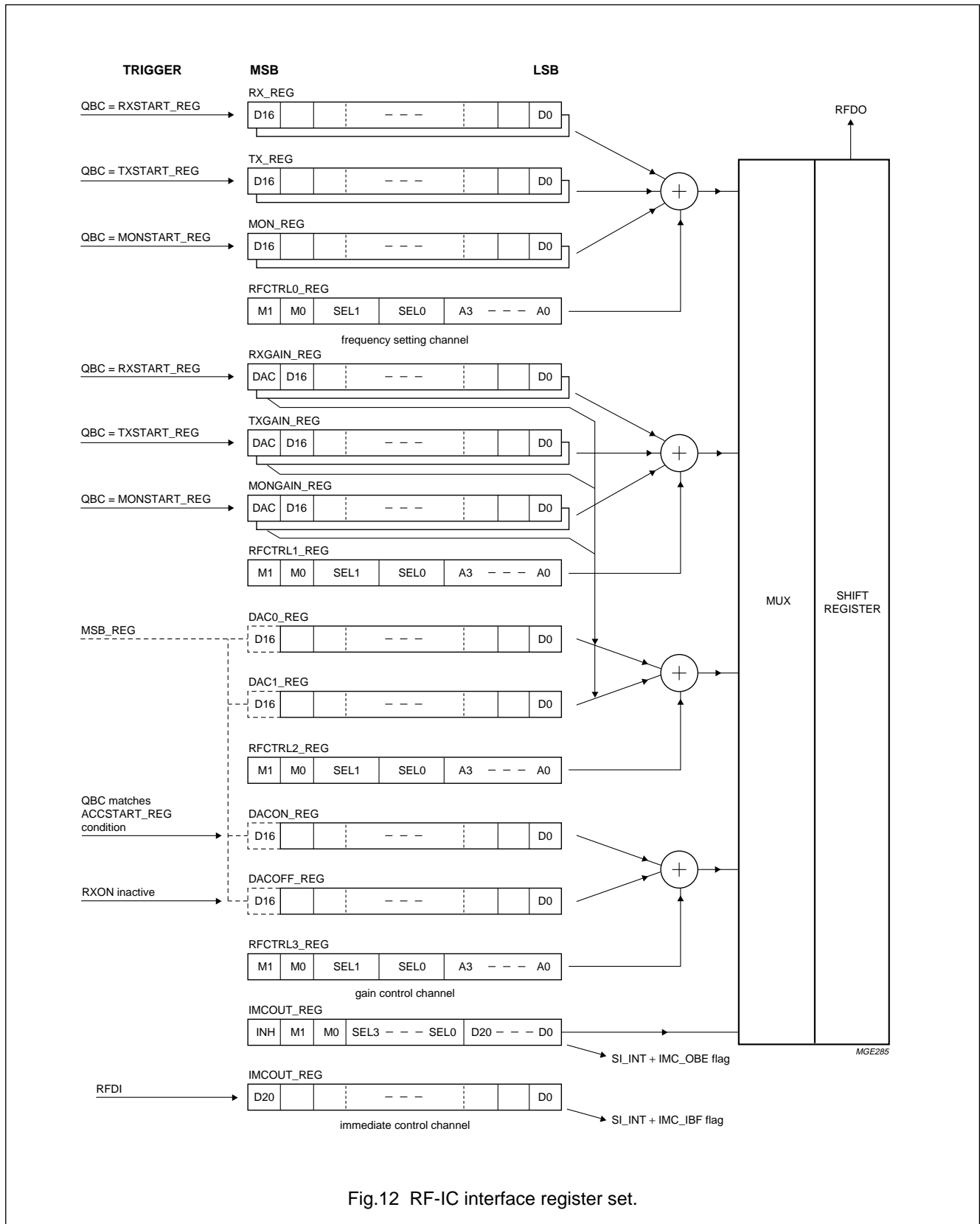

Fig.12 RF-IC interface register set.

GSM signal processing IC

PCF5083

8.5 IOM<sup>®</sup>-2 Interface

The PCF5083 includes a type of PCM Highway like digital Data and Voice interface which is also available for external devices. It can be configured to be compatible to the IOM<sup>®</sup>-2 standard. The blocks connected to this bus inside the IC are the Y-Port of the DSP core, the IOM<sup>®</sup>-2 master and the Audio Interface. The clock and frame synchronization signals (DCL, FSC) are either generated internally or provided externally. Figure 13 shows the general structure of the IOM<sup>®</sup>-2 interface.

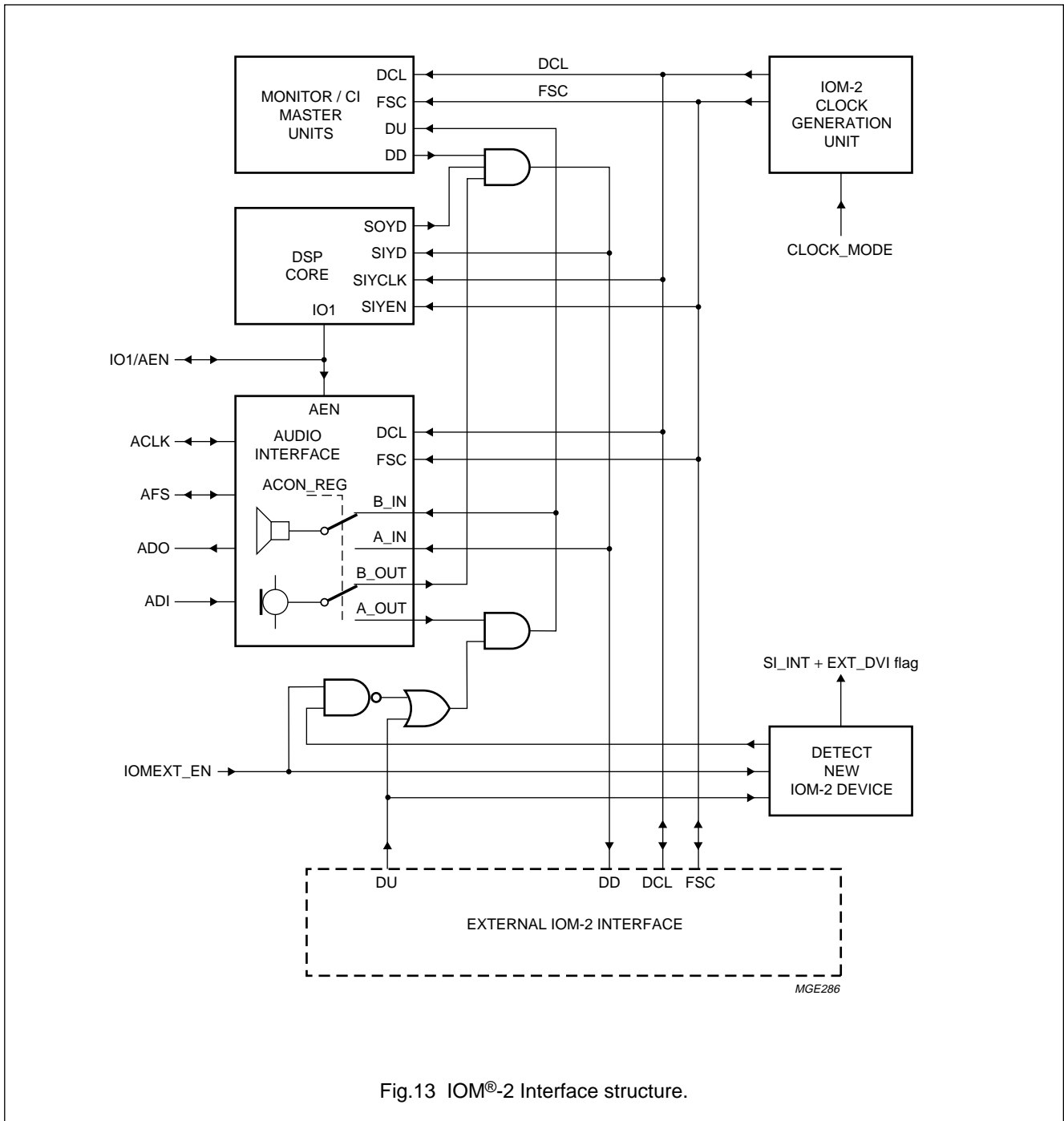

Fig.13 IOM<sup>®</sup>-2 Interface structure.

GSM signal processing IC

PCF5083

8.5.1 IOM<sup>®</sup>-2 CLOCK GENERATION

If the IOM<sup>®</sup>-2 clock and frame synchronization signals are generated internally from the 13 MHz reference clock, the basis clock runs at 1.536 MHz as illustrated in Fig.14. One 125 μs FSC period consists of 192 DCL periods (0 to 191). The DCL periods 12, 25, 38, 51, 64, 77, 90, 103, 116, 129, 142, 155, 168 and 181 are 8T wide (high time = low time = 4T), where T is the 13 MHz clock period (T = 77 ns). All other DCL periods are 8.5T wide (high time = 4.5T, low time = 4T).

It is possible to extend or to reduce 12 consecutive IOM<sup>®</sup>-2 frame periods by 1T each. This results in a total reduction or extension of one quarterbit (12T = 923 ns), which is required in case of timing alignment. This adjustment is performed by setting either the FSCEXT flag for extension, or the FSCRED flag for reduction. Both these flags reside in QCCTRL\_REG. The flags are automatically reset after the adjustment.

The length of the frame synchronization pulse (FSC) is chosen to  $29 \times 8.5T + 2 \times 8T + 6T = 268.5T$ .

The whole IOM<sup>®</sup>-2 signal generation is disabled in Clock mode 0 (see Table 23, default after reset).

In Sleep mode the REFON output stays active to keep the 13 MHz oscillator running as long as the IOM<sup>®</sup>-2 interface is not disabled (Clock mode 0).

Other clock modes are derived from this mode by subdividing the 1.536 MHz DCL clock by 2, 3, 4, 6, or 12. The FSC period is not changed.

In external clock mode the IOM<sup>®</sup>-2 clock and frame synchronization signal are provided via the DCL and FSC pins. The DCL clock in this mode is a multiple of 128 kHz or 256 kHz with a maximum frequency of 2.048 MHz or 4.096 MHz respectively.

In both internal and external clock modes, it is possible to select between a double clock cycle mode per data bit or a single clock cycle mode per data bit with the IOMCON\_REG[DATA\_MODE] flag. In double clock cycle mode the data output gets valid with the first rising edge of DCL and the data input is sampled with the second negative edge of DCL within a bit period. In single clock cycle mode the data output gets valid with the rising edge of DCL and the data input is sampled with the falling edge of DCL within a bit period. Data is organized in 16-bit timeslots. The maximum number of timeslots supported is 12 in internal and 16 in external clock mode.

Table 23 lists all possible clock modes.

Table 23 IOM<sup>®</sup>-2 Clock Modes

DCL FREQUENCY	SINGLE(1)/DOUBLE(2) CLOCK CYCLE MODE	NUMBER OF 16-BIT TIMESLOTS	DIVISION RATIO	CLOCK_MODE FLAGS (DEC.)	DATA_MODE FLAG
IOM <sup>®</sup> -2 interface off	–	–	–	0	x
1.536 MHz	2	6	1	1	1
1.536 MHz	1	12	1	1	0
768 kHz	1	6	2	2	0
768 kHz	2	3	2	2	1
512 kHz	2	2	3	3	1
512 kHz	1	4	3	3	0
384 kHz	1	3	4	4	0
256 kHz	2	1	6	5	1
256 kHz	1	2	6	5	0
128 kHz	1	1	12	6	0
external clock n × 128 kHz (2.084 MHz max.)	1	n (n ≤ 16)	–	7	0
external clock n × 256 kHz (4.096 MHz max.)	2	n (n ≤ 16)	–	7	1

GSM signal processing IC

PCF5083

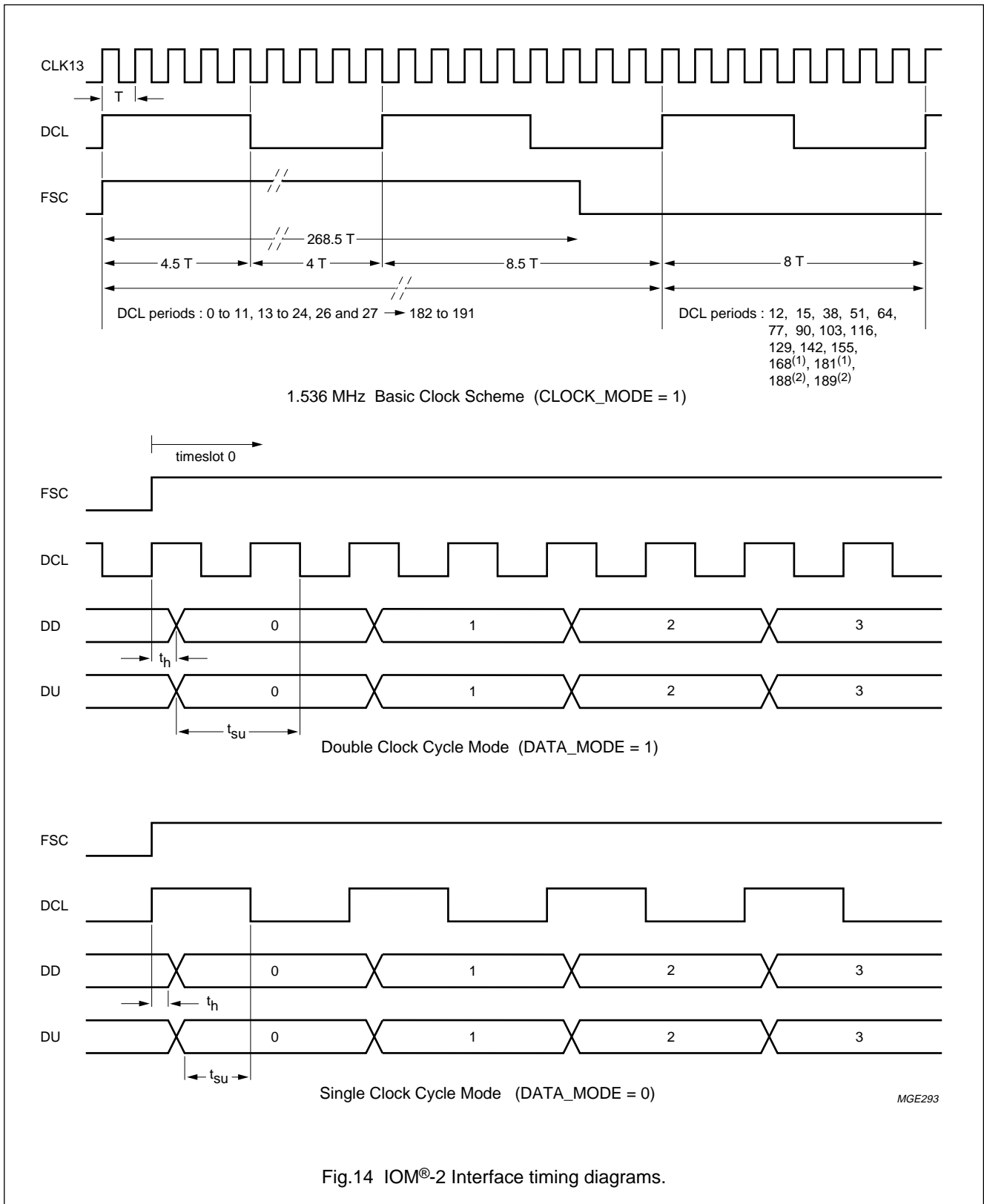

Fig.14 IOM<sup>®</sup>-2 Interface timing diagrams.

GSM signal processing IC

PCF5083

8.5.2 IOM<sup>®</sup>-2 MASTER UNIT

The IOM<sup>®</sup>-2 master unit implements two monitor channels and C/I channel masters. All handshake protocols are implemented in accordance with the IOM<sup>®</sup>-2 standard with the exception of the constraints mentioned below. The data structure of a 16-bit monitor and C/I timeslot is also implemented according to the IOM<sup>®</sup>-2 standard with the exception that the timeslot location is not fixed within a IOM<sup>®</sup>-2 frame.

As data is structured in 16-bit timeslots (see Table 24) the timeslot a master works on, can be selected with the flags IOMCON\_REG[MASTERx\_TS0 to MASTERx\_TS3]. These bits binary encode the timeslot number (0 to 5), with timeslot 0 being indicated with the rising edge of FSC.

Both monitor masters can be independently enabled with the flags IOMCON\_REG[MASTERx\_EN].

For every serviced channel a data register (MON0\_REG, MON1\_REG, CI0\_REG and CI1\_REG) with input and output buffer stage and a state machine for receive and transmit direction exists. For every register IOMFLAG\_REG holds two flags to indicate the input data buffer full and the output buffer empty condition. The flags are xxx\_IBF (input buffer full) and xxx\_OBE (output buffer empty) with xxx equal to the register name. If one of these flags together with the corresponding enable flag in IOMEN\_REG is set the IOM<sup>®</sup>-2 interrupt is activated (refer to Section 10.2). The flags are reset with read respectively write operations to their corresponding data register.

8.5.3 MONITOR CHANNEL TRANSMITTER PROTOCOL

- After IOMCON\_REG[MASTERx\_EN] is set to a logic 1, the transmitter state machine is in an idle state. The pattern FFH is sent and the output buffer empty flag MONx\_OBE (x = 1 or 2) is set. The MX flag is sent as a logic 1 in accordance with the IOM<sup>®</sup>-2 specifications.
- To initiate a message transmission the System Controller has to program MONx\_REG with the first byte of the message. The MONx\_OBE flag is cleared with the data write access.

- A full handshake is implemented in accordance with the IOM<sup>®</sup>-2 specifications. The transmitter may delay the data transmission in case the System Controller does not provide new data in time. MX = 0 is maintained until MONx\_REG is programmed with new data. The MONx\_OBE flag is cleared with the data write access. The receiver delays the data transmission if it sends no data acknowledge. In this case MX = 0 is maintained and the data byte is repeated in subsequent frames.
- To request new data from the controller the MONx\_OBE flag may be set as soon as the data acknowledge (MR = 1) from the receiver is detected except for the first byte reception. Here the MR transition HIGH-to-LOW has to be detected. This leaves the controller approximately 250 μs to program the MONx\_REG with the next byte without delay within the handshake procedure except for the first byte.
- An end of transmission is sent if the TEOMx flag in IOMCTRL\_REG is set when MONx\_OBE = 1 after the last byte transmission. The end of transmission is sent (MX = 1 in at least two subsequent frames) after the acknowledge of the last byte is completely received. After the end of transmission is sent the transmitter state machine is in the idle state.
- The TEOMx flags are also used to initialize the transmitter state machine. If the flag is set the state machine may get from any state into the idle state.
- The TEOMx flag is automatically cleared.
- If an abort request is received, the transmitter in accordance with the specifications, sends the end of transmission sequence and enters the idle state. The MONx\_OBE flag is set. The abort request is indicated with the RABORTx flag set in IOMCTRL\_REG. RABORTx = 1 also asserts the IOM<sup>®</sup>-2 interrupt (MONx\_OBE\_EN is used as enable bit) to indicate the abort to the System Controller. The flag is reset with the MONx\_OBE flag.

**Table 24** Data structure of a 16-bit IOM<sup>®</sup>-2 monitor and C/I master timeslot

15	14	13	12	11	10	9	8	7	6	5	4	3	2	1	0
MONX								C/IX						MR	MX

GSM signal processing IC

PCF5083

8.5.4 MONITOR CHANNEL RECEIVER PROTOCOL

- After IOMCON\_REG[MASTERx\_EN] is set to a logic 1, the receiver state machine is in an idle state and waits for the first byte transmission. The input buffer full flag MONx\_IBF is cleared. The MR flag is sent as a logic 1 in accordance with the IOM<sup>®</sup>-2 specification.
- After the reception of a data byte the MONx\_IBF flag is set and the System Controller may read the data from MONx\_REG.
- A full handshake is implemented in accordance with IOM<sup>®</sup>-2 specification. The receiver may delay the data transmission if the input buffer is full and the System Controller does not read the buffer in time. In this case MR = 0 is maintained until MONx\_REG is read. The MONx\_IBF flag is cleared with the data read access. The transmitter may delay the data transmission if it delays the next byte valid indication. In this case MR = 0 is maintained in subsequent frames.
- If an end of transmission is detected the receiver state machine gets into the idle state. The REOMx flag in IOMCTRL\_REG is set. REOMx = 1 also asserts the IOM<sup>®</sup>-2 interrupt (IOMx\_IBF\_EN is used as enable bit) to indicate the end of transmission to the System Controller. The REOMx flag is cleared with a dummy read of MONx\_REG.
- To send an abort request the TABORTx flag in IOMCTRL\_REG is set. The receiver state machine enters the idle state. The TABORTx flag is reset after the procedure.

Time-outs are not detected. Collision detection and the maximum speed case is not supported.

8.5.5 COMMAND/INDICATION CHANNEL TRANSMITTER

All data words are sent at least in two subsequent frames. If the transmitter runs out of data the last data word is repeated. The flags CI0(1)\_IBF and CI0(1)\_OBE are provided to indicate the input/output register status.

8.5.6 COMMAND/INDICATION CHANNEL RECEIVER

If the received data is different from the data input buffer the new data pattern is loaded into the data input buffer. The CI0(1)\_IBF flag is cleared if it is set. If during the next frame the received data is identical to the data stored in the data input buffer the buffer contents is considered valid and the CI0(1)\_IBF flag is set. The System Controller now has to fetch the data within the next 125 μs, otherwise data might be lost.

8.5.7 AUDIO INTERFACE

The Audio Interface provides the translation of one 16-bit IOM<sup>®</sup>-2 timeslot into a timing according to Chapter 16 for the receive and transmit direction. The operation of the interface is configurable with the flags of register ACON\_REG. The Audio Interface is enabled or disabled under control of the DSP core with IO1/AEN = 1. Otherwise the data word 00H is sent in both directions.

With ACON\_REG[TRANS\_EN] = 1, a transparent mode is selected. In this mode the internal IOM<sup>®</sup>-2 signals FSC and DCL are directly connected to ACLK and AFS. ADI is directly connected to A\_OUT or B\_OUT and ADO to A\_IN or B\_IN.

The following should be noted:

- The flags in register ACON\_REG should only be changed when the Audio Interface is disabled with IO1/AEN = 0
- The Audio Interface can only operate in the transparent mode if a timing mode is selected which results in only one 16-bit timeslot on the IOM<sup>®</sup>-2 side
- The frequency of ACLK must be chosen such that the complete transmission of a 16-bit word via the Audio Interface does not exceed the duration of N-1 timeslots, with N equal to the number of 16-bit timeslots on the IOM<sup>®</sup>-2 side
- Jitter is not allowed on AFS and ACLK as audio data might get corrupted.

Table 25 Audio Interface configuration register (ACON\_REG)

BIT	FLAG	OPERATION (if bit is set)
0	TX_EN	Enable transmit direction (ADI to IOM <sup>®</sup> -2).
1	TX_DEST	Select output to IOM <sup>®</sup> -2. A logic 0 selects A_OUT; a logic 1 selects B_OUT.
2	RX_EN	Enable receive direction (IOM <sup>®</sup> -2 to ADO).
3	RX_SOURCE	Select input from IOM <sup>®</sup> -2. A logic 0 selects A_IN; a logic 1 selects B_IN.
4 to 7	TX_SLOT0 to TX_SLOT3	IOM <sup>®</sup> -2 timeslot translated from the transmit section (0 to 15).
8 to 11	RX_SLOT0 to RX_SLOT3	IOM <sup>®</sup> -2 timeslot translated from the receive section (0 to 15).
12	TRANS_EN	Enable transparent mode.



## GSM signal processing IC

## PCF5083

### 8.5.8 EXTERNAL IOM<sup>®</sup>-2 INTERFACE

This block provides an IOM<sup>®</sup>-2 interface for external devices and accessories e.g. digital handsfree equipment data and fax interfaces etc. It is used as an interface to the system simulator during type approval.

The external IOM<sup>®</sup>-2 interface (DCL, FSC, DU and DD) is only enabled if the flag IOMCON\_REG[IOMEXT\_EN] is set. Otherwise, unless in external clock mode, the outputs DCL, FSC and DD are in their high-impedance state and the input DU is don't care (default after reset). In external clock mode the flag IOMCON\_REG[IOMEXT\_EN] flag only controls the data lines DU and DD. DCL and FSC are inputs in this mode independently from the state of the flag. If the flag IOMCON\_REG[IOMEXT\_INV] is set, all I/Os of the external IOM<sup>®</sup>-2 interface are inverted to allow the use of an external inverting driver circuit.

If the external IOM<sup>®</sup>-2 interface is disabled with IOMCON\_REG[IOMEXT\_EN] = 0, the DU input is externally pulled-up and will be monitored for a LOW level. An external device has to pull-down this line to register itself. If a LOW on DU was detected, the SI\_INT interrupt is activated with flag SIINT\_REG[EXT\_IOM] set. The flag and therefore the interrupt condition is automatically cleared after IOMCON\_REG[IOMEXT\_EN] was set.

### 8.6 MMI Interface

The PCF5083 provides a RS232 and a Power-down interface to fully support the MMI controller TDA8005.

#### 8.6.1 RS232 INTERFACE

This block provides a full RS232 interface with a fixed 8E1 protocol configuration.

The shift clock is derived from the 1 MHz clock for normal operation. For test purposes a clock applied at input ADI is used if SYSCON\_REG[RS232\_CLK] is set. The clock is divided by  $12 \times 3 \times 16$  to derive the shift clock. This results in a baud rate of 22569.44 Baud at 13 MHz. The receiver works with an oversampling of 16.

##### 8.6.1.1 Transmit

After writing to the register TXD\_REG, the register content is serially clocked out. The SIINT\_REG[TXD\_OBE] flag is set and the SI\_INT interrupt is generated (refer to Section 10.2). The flag and therefore the interrupt condition is cleared after writing the next data byte to register TXD\_REG.

##### 8.6.1.2 Receive

The incoming serial data stream is clocked into register RXD\_REG. SIINT\_REG[RXD\_IBF] is set after a data byte was received and the SI\_INT interrupt is generated. The state of the RXD\_IBF flag is available on the  $\overline{\text{MMIEN}}$  output and is used to implement a hardware handshake to the TDA8005. The SIINT\_REG[PAR\_ERR] flag signals a parity error and will be updated when the RXD\_IBF flag goes active. The RXD\_IBF flag and therefore the interrupt condition is cleared automatically after reading the register RXD\_REG.

Both interrupt conditions can be disabled with the corresponding mask flags in SIMASK\_REG. The flag handling remains the same as described.

The output  $\overline{\text{MMIEN}}$  is set to a logic 1 as long as HWCTRL\_REG[MMICLK] = 0.

Note that PAR\_ERR is not used as an interrupt condition.

#### 8.6.2 MMI POWER-DOWN INTERFACE

The MMI power-down interface controls the power consumption of the MMI controller (MMIC) TDA8005 by halting its main 13 MHz clock. The following signals are used:

- MMICLK: 13 MHz clock output, main clock for the MMIC
- MMIREQ: MMI clock request input.

The MMI wake-up and power-down procedures are:

1. Force MMIC into power-down mode:  
Set HWCTRL\_REG[MMICLK] = 0 to stop the 13 MHz MMI clock. The MMICLK output is held LOW and the output  $\overline{\text{MMIEN}}$  of the RS232 interface is set HIGH.
2. Wake-up MMIC via System Controller:  
Set HWCTRL\_REG[MMICLK] = 1 to activate MMICLK.
3. Wake-up MMIC after keyboard or SIM card reader activity:  
In this case the MMIC generates a LOW-to-HIGH transition on pin MMIREQ. The flags MMIREQ and MMICLK in register HWCTRL\_REG will be set and the MMICLK output is activated. If the timing generator unit (SGU) is in Sleep mode, a wake-up request is issued to force the SGU into the wake-up state. In the wake-up state HWCTRL\_INT and MMICLK are activated. The MMIREQ flag has to be explicitly cleared by the System Controller.

GSM signal processing IC

PCF5083

It should be noted that:

- A LOW-to-HIGH transition of MMIREQ is detected independent of HWCTRL\_REG[MMICLK] respectively.
- As long as HWCTRL\_REG[MMICLK] = 1, the REFON output stays active even if the SGU enters Sleep mode.

During power-up reset indicated with  $\overline{RST}$  active LOW, HWCTRL\_REG[MMICLK] is set and MMICLK is activated.

**8.7 General purpose parallel I/O port**

The PCF5083 includes a 6-bit general purpose parallel I/O port. Every I/O line, except PIO0, has a corresponding data bit in PORTDATA\_REG and a data direction bit in PORTDDIR\_REG. The bits in PORTDATA\_REG directly represent the state of the I/O pins if the port is configured as an input. Otherwise if the port is configured as output, the data written to PORTDATA\_REG directly represents the state of the port line. A logic 1 in PORTDDIR\_REG configures the port line as an output, a logic 0 as an input.

PIO0 is configured as output only. It is used internally to drive the reset input of the DSP core.

**8.8 Real Time Clock**

A real time/alarm time clock unit is included in the timer core. The clock unit is driven from the 32.768 kHz crystal oscillator. A leap year function is included. The clock function utilizes the registers/counters specified in Table 26.

**Table 26** Clock function registers/counters

REGISTERS/ COUNTERS	CLOCK FUNCTION
SEC_REG	seconds, 00 to 59, two 4-bit digits BCD encoded
MIN_REG	minutes, 00 to 59, two 4-bit digits BCD encoded
HOUR_REG	hours, 00 to 23, two 4-bit digits BCD encoded
DAY_REG	day, 0 to 6, 0 = Monday to 6 = Sunday
DATE_REG	date, 0 to 31, two 4-bit digits BCD encoded
MONTH_REG	month, 01 to 12, two 4-bit digits BCD encoded
YEAR_REG	year, 00 to 99, two 4-bit digits BCD encoded

If the flag HWCTRL\_REG[SECINT] is reset, the hardware control interrupt (HWCTRL\_INT, refer to Section 10.2) is asserted with the HWCTRL\_REG[CLOCK] flag set every time MIN\_REG is incremented. Otherwise if the flag is set, the interrupt is asserted every time SEC\_REG is incremented.

**8.8.1 SETTING THE REAL TIME CLOCK**

To set the real time clock, the SETCLOCK bit in HWCTRL\_REG must be set to a logic 1. The flag is then polled until it is read as a logic 1 again. This action may last up to 0.5 s. After SETCLOCK = 1 is detected, the clock registers can be written. After the write operation SETCLOCK has to be reset again. If the register setting takes place immediately after the hardware control interrupt was asserted, the clock registers may be written without polling of the SETCLOCK flag (SETCLOCK still has to be set prior and reset after the register write operation).

The following should be noted:

- If the Sleep mode is invoked, a wake-up request is generated every time the hardware control interrupt is asserted. To increase performance it is not recommended to use the interrupt facility at a rate of one second during Sleep mode.

An alarm function is implemented using the registers SEC\_A\_REG, MIN\_A\_REG, HOUR\_A\_REG, DAY\_A\_REG, DATE\_A\_REG, MONTH\_A\_REG and YEAR\_A\_REG. If the contents of these registers equals the corresponding counters, the hardware control interrupt is asserted with the flag HWCTRL\_REG[ALARM] set. If all bits are set to one in one of the registers (07H in case of the DAY\_A\_REG) it is don't care for the comparison. If the alarm function is activated while the MS is switched off, the MS is powered up as described in Section 8.2.1.

If  $\overline{RSTC}$  is activated the clock counters are reset to 00H, except date and month which are set to 01H. MONTH\_A\_REG is set to 00H to avoid an alarm condition. The other alarm registers are undefined.

## GSM signal processing IC

## PCF5083

## 9 DESCRIPTION OF THE DSP CORE

## 9.1 Interface description

## 9.1.1 BASEBAND DIGITIZER INTERFACE

The PCF5083 serial input port SIX is used for the reception of off-air data from the baseband digitizer PCF5072 (BBD).

The port consists of:

- Serial Input Data signal (SIXD), containing 16I and 16Q data bits, MSB first
- Serial Input Clock signal (SIXCLK), running at 13 MHz
- Serial Input Enable signal (SIXEN), active LOW.

Regularly spaced I and Q samples are sent to the DSP with a periodicity of  $1/(2 \cdot 270.833 \text{ kHz})$ ; (twice the GSM bit period). The number of incoming samples expected by the DSP depends upon the current status in which the DSP is operating (see Table 27).

The column START OF SAMPLING indicates in which time slot (1 time slot =  $1/8$  TDMA frame =  $577 \mu\text{s}$ ) the sampling of the I and Q pairs has to start.

Time slots are numbered from 0 to 7, whereby slot 0 is defined as the receive time slot of the mobile station (see Section 8.3.2.1).

Each I/Q component pair is represented by two 16-bit two's complement numbers, as shown in Table 28, with one sign bit (I15 and Q15) and 15 fractional bits. The range for the I and Q components is specified below.

Range:  $-1.0 \leq I, Q < +1.0$

It should be noted that due to the limited SNR of the PCF5072 of 66 dB, only the 11 MSBs of I and Q contain meaningful data.

The I and Q components are defined as follows:

$$I = f(A) \times \cos \Phi$$

$$Q = f(A) \times \sin \Phi$$

where A is the magnitude and  $\Phi$  is the phase of the antenna input signal. The function  $f(A)$  describes the characteristic of the AGC applied (see Fig.16).

**Table 27** Time window for BBD output data

OPERATION STATUS	START OF SAMPLING	NUMBER OF I AND Q PAIRS
Reception of a normal burst	TS 0	149
Reception of a synchronization burst	–	167
Reception of a normal burst	TS 0	167
Level measurement of neighbouring BCCH	TS 5	80
DC offset measurement	TS 5	128
FCB search	TS 6	1404 <sup>(1)</sup> ( $9 \times 156$ )

**Note**

1. The value 1404 for FCB search is the default value after reset. It can be changed by the FB\_search\_fcb\_init procedure.

**Table 28** I and Q component format

BIT	15	14	13	12	11	10	9	8	7	6	5	4	3	2	1	0
I	I15	I14	I13	I12	I11	I10	I9	I8	I7	I6	I5	I4	I3	I2	I1	I0
Q	Q15	Q14	Q13	Q12	Q11	Q10	Q9	Q8	Q7	Q6	Q5	Q4	Q3	Q2	Q1	Q0

GSM signal processing IC

PCF5083

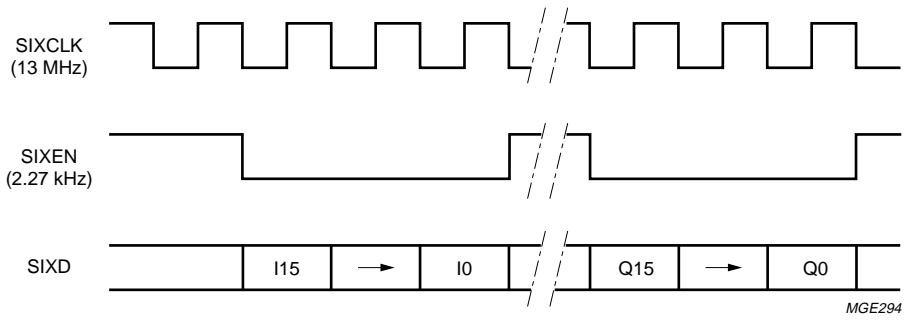

Fig.15 Baseband RX Timing diagram.

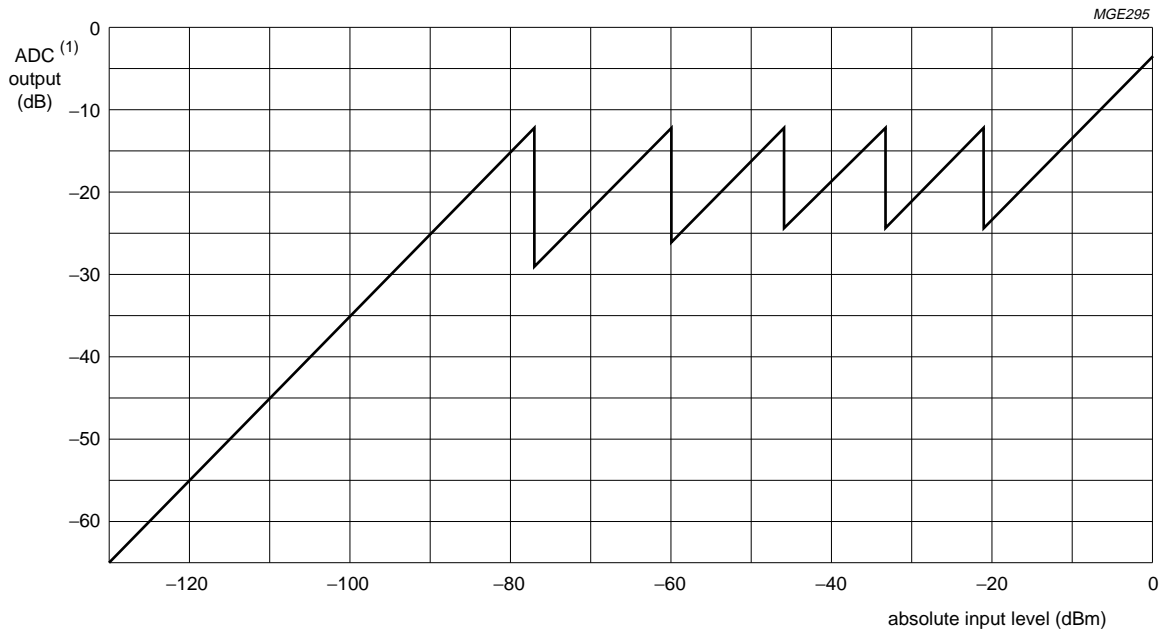

Fig.16 AGC characteristic.

## GSM signal processing IC

## PCF5083

## 9.1.2 GMSK MODULATOR INTERFACE

The PCF5083 serial output port SOX is used to transmit the coded, interleaved and formatted bits to the GMSK modulator in the PCF5072 baseband interface IC.

The SOX port consists of:

- Serial Output Data signal (SOXD)
- Serial Output Clock signal (SOXCLK), running at 270.83 kHz
- Serial Output Enable signal (SOXEN), active LOW.

The GSM bit clock is directly used as the external shift clock, therefore no external buffering of transmission data is necessary.

The PCF5083 general purpose I/O pin IO4 is used to enable or disable the transmitter during DTX. If IO4 = 0, the transmitter is enabled. If IO4 = 1, the transmitter is disabled. It is sampled by the TDMA timer at the beginning of the transmit burst period.

## 9.1.2.1 Burst format

Tables 29 and 30 show the format of the normal and access burst produced by the DSP. The period of the 8 leading bits allows the power amplifier to ramp-down and ramp-up.

**Table 29** Normal burst format

BITS	NUMBER OF BITS	DESCRIPTION
0 to 7	8	dummy bits (set to logic 1)
8 to 155	148	BN0 to BN147 in accordance with "GSM Rec. 05.02"

**Table 30** Access burst format

BITS	NUMBER OF BITS	DESCRIPTION
0 to 7	8	dummy bits (set to logic 1)
8 to 95	88	BN0 to BN87 in accordance with "GSM Rec. 05.02"
96 to 155	60	dummy bits (set to logic 1)

## 9.1.3 AUDIO AND DATA INTERFACE

The PCF5083 serial port Y is connected on-chip to the IOM<sup>®</sup>-2 interface of the Timer Core. It is used for connection to the following devices:

- PCM codec in the PCF5072
- Digital Audio Interface (DAI), used during type approval
- Terminal adaptor for data services
- External digital answering machine.

The physical transfer order on the IOM<sup>®</sup>-2 bus is 16-bit, MSB first. The following signals are used:

- Serial data input SIYD
- Serial data output SOYD
- Serial shift clock SIYCLK
- Frame synchronization input SIYEN.

The DSP by default reads and writes the first 16-bit timeslot of the IOM<sup>®</sup>-2 interface. This may be changed with the appropriate software command to any 16-bit timeslot.

Input and output from/to the IOM<sup>®</sup>-2 bus is performed via two FIFOs named audio input and audio output FIFO. These FIFOs are implemented by firmware. Each FIFO is able to store up to 297 16-bit samples.

GSM signal processing IC

PCF5083

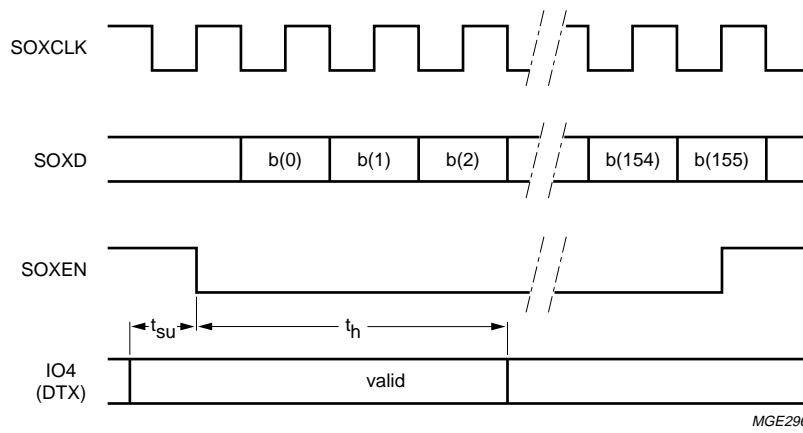

MGE296

DTX setup time:  $t_{su} > 0$   
 DTX hold time:  $t_h > 124 \times 3.69 \mu s$

Fig.17 GSMK modulator timing diagram.

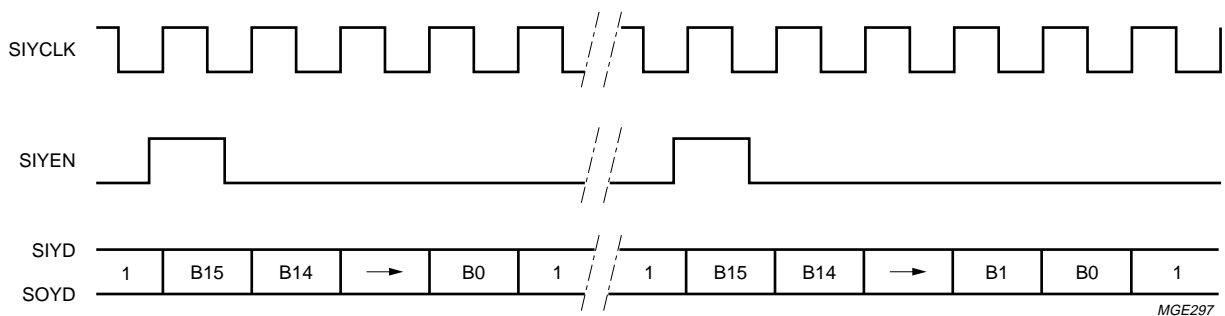

MGE297

Fig.18 Audio and Interface timing (default).

## GSM signal processing IC

PCF5083

## 9.1.4 AUDIO INTERFACE

## 9.1.4.1 Downlink speech frame format

Every 20 ms the speech decoder in the DSP outputs a speech frame consisting of 160 16-bit words. These speech frames are transmitted to the PCM codec. The speech frame format is described in Table 32.

**Table 31** Field descriptions

FIELD	DESCRIPTION
SAMPLE	This field contains the 13-bit linear PCM audio samples in two's complement (MSB = sign bit) representation as defined by the "GSM recommendation 06.01".
PARM	Whenever the speech decoder is active the PARM field is used to transfer the speech parameters (D1 to D260) together with some frame classification information (see Table 99) and the currently selected test mode (see Table 34) out of the DSP. The terms SP (speech flag), SID (silence descriptor) and MUF (muting flag) are defined in "GSM Rec. 06.31" (DTX for full-rate speech TCH). The HF bit indicates, whether the speech codec is operating in handsfree mode (HF = 1) or not. The bits TM2 to TM0 are intended to be evaluated by an external Digital Audio Interface (DAI). They determine the currently selected test mode during type approval as described in "GSM Rec. 11.10, Section III.1.2.4.7". TM2 to TM0 are passed in the TMODE file of the operation_mode parameter of the speech decoder procedure. Refer to Section 9.3.1 for more information.
SYNC	Synchronization signal for external (test) equipment. Marks the 20 ms speech frames. Each falling edge of SYNC marks the beginning of a new output speech frame and with a constant offset due to internal module processing time the rising edge of SYNC marks a new input speech frame. As soon as audio output data are available this bit always reflects the internal speech frame timing independently of other processing tasks of the DSP.

**Table 32** Downlink speech frame format

OFFSET	SAMPLE FIELD													PARM FIELD		SYNC FIELD
	15	14	13	12	11	10	9	8	7	6	5	4	3	2	1	0
0	audio sample 0													TM1	TM0	0
1	audio sample 1													HF	TM2	0
2	audio sample 2													0	0	.
3 to 27	audio samples 3 to 27													not used		.
28	audio sample 28													SID	0	0
29	audio sample 29													MUF	SP	.
30	audio sample 30													D2	D1	.
31	audio sample 31													D4	D3	.
32 to 157	audio samples 32 to 157													.	.	.
158	audio sample 158													D258	D257	.
159	audio sample 159													D260	D259	1

## GSM signal processing IC

PCF5083

**Table 33** Frame classification

FRAME TYPE	SP	SID2	MUF
Speech frame	1	0	0
Transmitted SID	0	1	0
Repeated SID	0	0	0
Silence frame	1	0	1
Reserved	all other codes		

**Table 34** Test mode selection

DESCRIPTION	TM2	TM1	TM0
Normal operation (no tested divide via DAI)	0	0	0
Test of speech decoder/DTX functions (downlink)	0	0	1
Test of speech encoder/DTX functions (uplink)	0	1	0
Test of acoustic devices and ADCs and DACs	1	0	0
Reserved	all other codes		



## GSM signal processing IC

## PCF5083

## 9.1.4.2 Uplink Speech Frame Format

Every 20 ms the speech encoder in the DSP requires a speech frame consisting of 160 16-bit words. The speech frame format is described in Table 36. Each word consists of three fields as shown in Table 35.

**Table 35** Field descriptions

FIELD	DESCRIPTION
SAMPLE	This field contains the 13-bit linear PCM audio samples in two's complement (MSB = sign bit) representation as defined by the "GSM recommendation 06.01".
PARM	If the <code>bypass_flag</code> in <code>SP_encoder_TCHFS</code> procedure (see Section 9.3.1) is set to 1, the speech encoder is bypassed and the bits D1 to D260 are used as the coded speech frame. If <code>bypass_flag</code> is set to 2, the speech encoder is only bypassed, if the control flag <code>BM0</code> is set to 1 and <code>BM1</code> is set to 0. The <code>SP_R</code> flag indicates, either a speech frame ( <code>SP_R = 1</code> ) or a silence frame ( <code>SP_R = 0</code> ) is transmitted. Before the external device could send meaningful information, it has to synchronize to the rising edge of the <code>SYNC</code> bit (see Table 43).
RESD, RESE	RESet Decoder, RESet Encoder. In test mode (see Section 9.3.1 speech coding procedures) these bits behave as a reset signal for the speech decoder/encoder on a LOW-to-HIGH transition, RESD/RESE must remain set for at least 40 ms.

**Table 36** Uplink speech frame format

OFFSET	SAMPLE FIELD													PARM FIELD		RESD FIELD
	15	14	13	12	11	10	9	8	7	6	5	4	3	2	1	0
0	audio sample 0													RESE	not used	RESD
1	audio sample 1													not used		.
2 to 27	audio samples 2 to 27													not used		.
28	audio sample 28													BM1	BM0	.
29	audio sample 29													–	SP_R	.
30	audio sample 30													D2	D1	.
31	audio sample 31													D4	D3	.
32 to 157	audio samples 32 to 157													.	.	.
158	audio sample 158													D258	D257	.
159	audio sample 159													D260	D259	RESD

# GSM signal processing IC

# PCF5083

## 9.1.5 TERMINAL ADAPTOR INTERFACE FOR DATA SERVICES

### 9.1.5.1 General description

In Fig.19 the block diagram of the data service architecture using the PCF5083 is shown. The GSM terminal is connected to an external terminal adaptor via the IOM<sup>®</sup>-2 interface (serial port Y) of the PCF5083. Channel coding in accordance with "GSM recommendation 05.03" is done by the DSP, rate adaptation and e.g. Hayes command handling is done by the terminal adaptor.

There are two types of information that have to be exchanged between the terminal adaptor and the GSM terminal:

1. User data that has to be transmitted via the air interface. This is the input and output of the channel codec in the PCF5083
2. Control data which has to be exchanged between the System Controller and the terminal adaptor.

Data transfer via the IOM<sup>®</sup>-2 is done in form of data frames. Each data frame contains 160 16-bit samples (20 ms) and consists of a user data block containing user data to/from the channel codec and a control data block containing control data to/from the System Controller. The DSP firmware (the procedures MP\_read\_data\_frame and MP\_write\_data\_frame, see Section 9.3.1) performs multiplexing and demultiplexing of user and control data. Control data is forwarded to the System Controller or to the terminal adaptor, respectively without modification or interpretation by the DSP.

A fully integrated solution for the architecture of GSM data services is in preparation, at which rate adaptation is realised as an additional DSP software module, Hayes command interpretation is part of the P90CL301 software and data communications are done via the RS-232 port of the P90CL301.

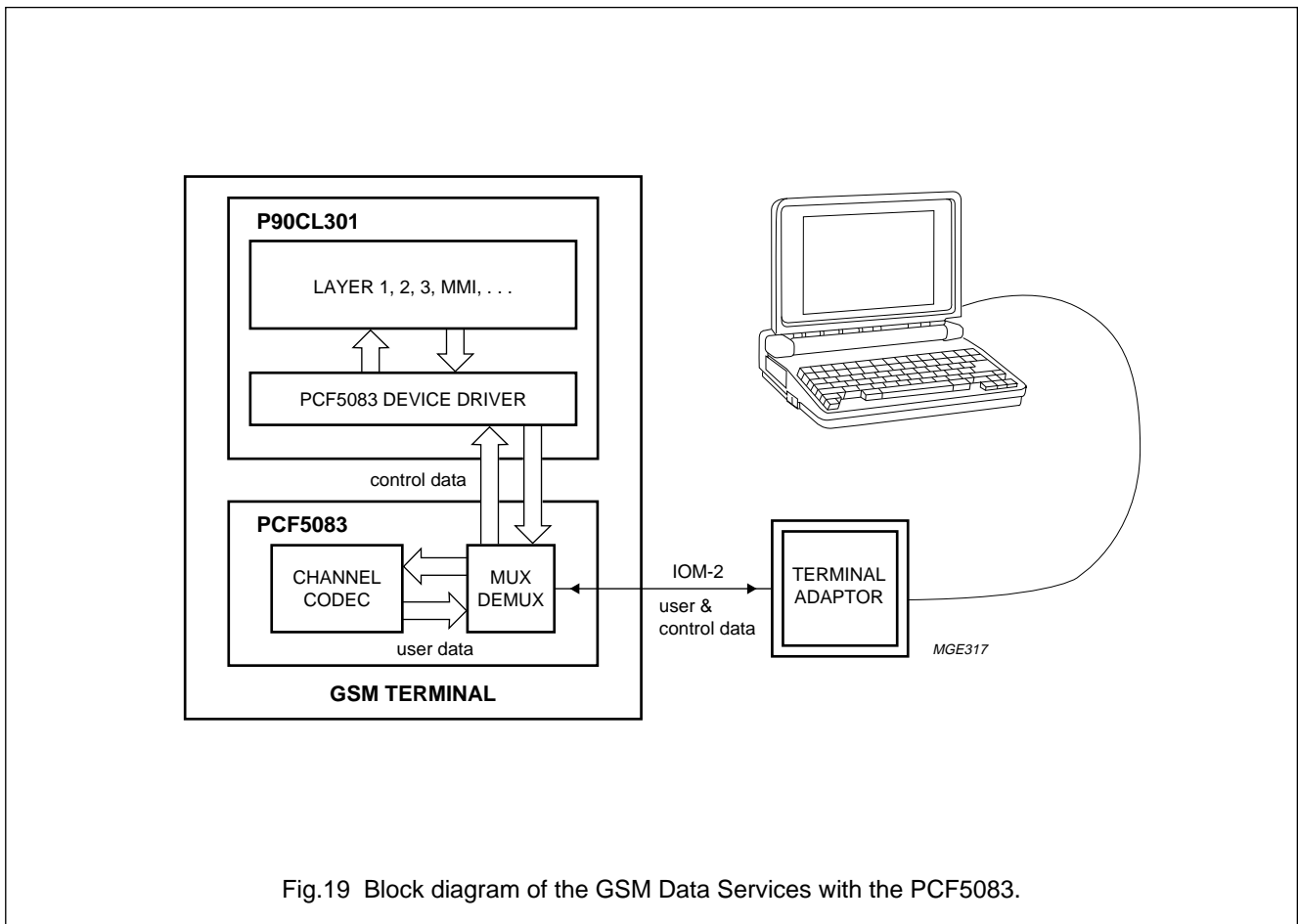

Fig.19 Block diagram of the GSM Data Services with the PCF5083.

## GSM signal processing IC

PCF5083

## 9.1.5.2 Format of downlink data frames

The downlink data frame format is described in Table 40. Each word consists of four fields; these are described in Table 37.

**Table 37** Field descriptions

FIELD	DESCRIPTION
DATA	Depending on the contents of the CMD field (see Table 38), this field contains a data byte belonging to a user or a control data block or auxiliary control information for the terminal adaptor.
CMD	This field classifies the 16-bit samples as described in the Table 38.
SYNC	Synchronization signal for external (test) equipment. Marks the 20 ms speech frames. Each falling edge of SYNC marks the beginning of a new output speech frame and with a constant offset due to internal module processing time the rising edge of SYNC marks a new input speech frame. As soon as audio output data are available this bit always reflects the internal speech frame timing independently of other processing tasks of the DSP.
INFO	This field may be used by external devices to distinguish between audio and data frames. The INFO field of word#2 contains the so called frame identification (FID); see Table 39.

**Table 38** Classification of the 16-bit samples

CMD FIELD					DESCRIPTION
7	6	5	4	3	
0	0	0	0	1	The data field contains a valid data byte belonging to either a user or a control data block.
0	0	0	1	0	The data field contains auxiliary control information that may be used by the terminal adaptor for synchronization purposes.
1	1	1	1	1	Indicates that the data field contains invalid data, which should be ignored.
Other combinations					Reserved for future expansion. Not used by the DSP.

**Table 39** Valid values for FID

FID <sup>(1)</sup>	FRAME TYPE
00	audio frame
01	data frame
1X	reserved

**Note**

1. Binary value; X = don't care.

GSM signal processing IC

PCF5083

Table 40 Downlink data frame format

OFFSET	DATA FIELD								CMD FIELD					INFO FIELD		SYNC FIELD	DESCRIPTION
	15	14	13	12	11	10	9	8	7	6	5	4	3	2	1	0	
0	0XFF								1	1	1	1	1	0	1	0	Header: to be used by the terminal adaptor for synchronization purposes
1	0XFF								1	1	1	1	1	0	1	0	
2	0XFF								1	1	1	1	1	FID = 01		0	
3 to 21	0XFF								1	1	1	1	1	0	1	0	
22	0X01								0	0	0	1	0	0	1	0	
23	0XFF								1	1	1	1	1	0	1	0	
24	0XFF								1	1	1	1	1	0	1	0	
25	0X00								0	0	0	1	0	0	1	0	
26	0XFF								1	1	1	1	1	1	1	1	
27	0XFF								1	1	1	1	1	1	1	1	
28	0XFF								1	1	1	1	1	1	1	1	
29	LU								0	0	0	0	1	0	0	1	
30	0XFF								1	1	1	1	1	1	1	1	
	0XFF								1	1	1	1	1	1	1	1	
	U[1]								0	0	0	0	1	1	1	1	
	0XFF								1	1	1	1	1	1	1	1	
	0XFF								1	1	1	1	1	1	1	1	
	U[2]								0	0	0	0	1	0	0	1	
	0XFF								1	1	1	1	1	1	1	1	
	U(LU – 1)								0	0	0	0	1	0	0	1	
	0XFF								1	1	1	1	1	1	1	1	
	0XFF								1	1	1	1	1	1	1	1	
	U(LU)								0	0	0	0	1	0	0	1	
	0XFF								1	1	1	1	1	1	1	1	
	0XFF								1	1	1	1	1	1	1	1	
	LC								0	0	0	0	1	0	0	1	Control data block; LC is the block length.  Valid range: 0 ≤ LC ≤ 8.
	0XFF								1	1	1	1	1	1	1	1	
	0XFF								1	1	1	1	1	1	1	1	
	C[0]								0	0	0	0	1	0	0	1	
	0XFF								1	1	1	1	1	1	1	1	
	0XFF								1	1	1	1	1	1	1	1	
	C[1]								0	0	0	0	1	0	0	1	
	0XFF								1	1	1	1	1	1	1	1	
	C(LC – 2)								0	0	0	0	1	0	0	1	
	0XFF								1	1	1	1	1	1	1	1	
	0XFF								1	1	1	1	1	1	1	1	
	C(LC – 1)								0	0	0	0	1	0	0	1	
159	0XFF								1	1	1	1	1	1	1	1	1

## GSM signal processing IC

## PCF5083

## 9.1.5.3 Format of uplink data frames

The uplink data frame format is described in Table 43. Each word consists of four fields; these are described in Table 41.

**Table 41** Field descriptions

FIELD	DESCRIPTION
DATA	This field contains the data bytes of user data block and control data block. Only words with CMD = 00001 contain valid data fields (see Table 42).
CMD	This field classifies the 16-bit samples as described in the Table 42.
SYNC, INFO	In uplink direction, these fields are without meaning.

**Table 42** Classification of the 16-bit samples

CMD FIELD					DESCRIPTION
7	6	5	4	3	
0	0	0	0	1	The data field contains a valid data byte belonging to either a user or a control data block.
0	0	0	1	0	The data field contains auxiliary control information that may be used by the terminal adaptor for synchronization purposes; note 1.
1	1	1	1	1	Indicates that the data field contains invalid data, which should be ignored.
Other combinations					Reserved for future expansion. Not used by the DSP.

**Note**

1. The external terminal adaptor may insert at any position an arbitrary number of fill words with CMD = 11111.

**Table 43** Uplink data frame format

OFFSET	DATA FIELD <sup>(1)</sup>								CMD FIELD					INFO FIELD		SYNC FIELD	DESCRIPTION
	15	14	13	12	11	10	9	8	7	6	5	4	3	2	1	0	
0	X								1	1	1	1	1	X	X	X	User data block; this block contains modified CCITT frame in accordance with "GSM Rec. 05.03". It is used as input data for the channel encoder. LU is the block length
	X								1	1	1	1	1	X	X	X	
	LU								0	0	0	0	1	X	X	X	
	U[0]								0	0	0	0	1	X	X	X	
	U[1]								0	0	0	0	1	X	X	X	
	U(LU – 2)								0	0	0	0	1	X	X	X	
	U(LU – 1)								0	0	0	0	1	X	X	X	
	LC								0	0	0	0	1	X	X	X	Control data block; the first byte LC is the block length. LC may also be zero. This block is forwarded to the System Controller.
	C[0]								0	0	0	0	1	X	X	X	
	C[1]								0	0	0	0	1	X	X	X	
	C(LC – 2)								0	0	0	0	1	X	X	X	
	C(LC – 1)								0	0	0	0	1	X	X	X	
159	X								1	1	1	1	1	X	X	X	Valid range: $0 \leq LC \leq 10$ .

**Notes**

1. X = don't care.

## GSM signal processing IC

## PCF5083

## 9.1.5.4 User data block formats

In the following sections the user data block formats for all data channels defined in "GSM Rec. 05.03" are explained. The formats for uplink and downlink directions are identical with the exception that three additional bytes are transmitted in the downlink direction:

- The first byte contains the `facch_flag`. This flag indicates whether the channel decoder has decoded a FACCH (`facch_flag = 1`) or not (`facch_flag = 0`).
- The other two bytes, `rxqual_ber_low` and `rxqual_ber_high`, indicate the estimated Bit Error Rate (BER) at the channel decoder input.

The Bit Error Rate can be calculated using the following equation:

$$\text{BER} = \frac{\text{rxqual\_ber\_low} + 256 \times \text{rxqual\_ber\_high}}{4096}$$

Tables 44 to 47 show the user data block format for full-rate and half-rate data channels running at different baud rates.

Note that the TCH/H4.8 format is used for half-rate data channels at 4.8 kbits/s. It is equivalent to the format used for TCH/F9.6 (see Table 46).

**Table 44** TCH/F2.4

The following table shows the user data block for full rate data channel at 2.4 kbit/s (and less). The  $2 \times 36$  data bits shown correspond to 2 modified CCITT V.110 36-bit frames.

DESCRIPTION	OFFSET	DOWNLINK DATA	UPLINK DATA
Block size	0	14	11
Valid flag	1	1	1
Modified CCITT frame 1	2	rb8 to rb1	rb8 to rb1
	3	rb16 to rb9	rb16 to rb9
	4	rb24 to rb17	rb24 to rb17
	5	rb32 to rb25	rb32 to rb25
	6	rb36 to rb33	rb36 to rb33
Modified CCITT frame 2	7	rb8 to rb1	rb8 to rb1
	8	rb16 to rb9	rb16 to rb9
	9	rb24 to rb17	rb24 to rb17
	10	rb32 to rb25	rb32 to rb25
	11	rb36 to rb33	rb36 to rb33
FACCH flag	12	<code>facch_flag</code>	–
<code>rxqual_ber</code>	13	<code>rxqual_ber_low</code>	–
	14	<code>rxqual_ber_high</code>	–

## GSM signal processing IC

## PCF5083

**Table 45** TCH/F4.8

The following table shows the user block data format for full rate data channel at 4.8 kbit/s. The  $2 \times 60$  data bits shown correspond to 2 modified CCITT V.110 60-bit frames according to "GSM 04 21".

DESCRIPTION	OFFSET	DOWNLINK DATA	UPLINK DATA
Block size	0	20	17
Valid flag	1	1	1
Modified CCITT frame 1	2	rb8 to rb1	rb8 to rb1
	3	rb16 to rb9	rb16 to rb9
	4	rb24 to rb17	rb24 to rb17
	5	rb32 to rb25	rb32 to rb25
	6	rb40 to rb33	rb40 to rb33
	7	rb48 to rb41	rb48 to rb41
	8	rb56 to rb49	rb56 to rb49
	9	rb60 to rb57	rb60 to rb57
Modified CCITT frame 2	10	rb8 to rb1	rb8 to rb1
	11	rb16 to rb9	rb16 to rb9
	12	rb24 to rb17	rb24 to rb17
	13	rb32 to rb25	rb32 to rb25
	14	rb40 to rb33	rb40 to rb33
	15	rb48 to rb41	rb48 to rb41
	16	rb56 to rb49	rb56 to rb49
	17	rb60 to rb57	rb60 to rb57
FACCH flag	18	facch_flag	–
rxqual_ber	19	rxqual_ber_low	–
	20	rxqual_ber_high	–

## GSM signal processing IC

## PCF5083

**Table 46** TCH/F9.6

The following table shows the full rate data channel at 9.6 kbit/s. The  $4 \times 60$  data bits shown correspond to 4 modified CCITT V.110 60-bit frames in accordance with "GSM 04.21". For non-transparent services those four blocks shall align with one 240-bit RLP frame. The valid\_flag indicates, whether the data block contains valid data (valid\_flag = 1) or not (valid\_flag = 0). It is used for DTX.

DESCRIPTION	OFFSET	DOWNLINK DATA	UPLINK DATA
Block size	0	36	33
Valid flag; note	1	1	valid flag
Modified CCITT frame 1	2	rb8 to rb1	rb8 to rb1
	3	rb16 to rb9	rb16 to rb9
	4	rb24 to rb17	rb24 to rb17
	5	rb32 to rb25	rb32 to rb25
	6	rb40 to rb33	rb40 to rb33
	7	rb48 to rb41	rb48 to rb41
	8	rb56 to rb49	rb56 to rb49
	9	rb60 to rb57	rb60 to rb57
Modified CCITT frame 2	10	rb8 to rb1	rb8 to rb1
	11	rb16 to rb9	rb16 to rb9
	12	rb24 to rb17	rb24 to rb17
	13	rb32 to rb25	rb32 to rb25
	14	rb40 to rb33	rb40 to rb33
	15	rb48 to rb41	rb48 to rb41
	16	rb56 to rb49	rb56 to rb49
	17	rb60 to rb57	rb60 to rb57
Modified CCITT frame 3	18	rb8 to rb1	rb8 to rb1
	19	rb16 to rb9	rb16 to rb9
	20	rb24 to rb17	rb24 to rb17
	21	rb32 to rb25	rb32 to rb25
	22	rb40 to rb33	rb40 to rb33
	23	rb48 to rb41	rb48 to rb41
	24	rb56 to rb49	rb56 to rb49
	25	rb60 to rb57	rb60 to rb57
Modified CCITT frame 4	26	rb8 to rb1	rb8 to rb1
	27	rb16 to rb9	rb16 to rb9
	28	rb24 to rb17	rb24 to rb17
	29	rb32 to rb25	rb32 to rb25
	30	rb40 to rb33	rb40 to rb33
	31	rb48 to rb41	rb48 to rb41
	32	rb56 to rb49	rb56 to rb49
	33	rb60 to rb57	rb60 to rb57



## GSM signal processing IC

## PCF5083

DESCRIPTION	OFFSET	DOWNLINK DATA	UPLINK DATA
FACCH flag	34	facch_flag	–
Rxqual_ber	35	rxqual_ber_low	–
	36	rxqual_ber_high	–

**Table 47** TCH/H2.4

The following table shows the user data block for half rate data channel at 2.4 kbit/s (and less). The  $4 \times 36$  data bits shown correspond to 4 modified CCITT V.110 36-bit frames according to GSM 04 21.

DESCRIPTION	OFFSET	DOWNLINK DATA	UPLINK DATA
Block size	0	24	21
Valid flag	1	1	1
Modified CCITT frame 1	2	rb8 to rb1	rb8 to rb1
	3	rb16 to rb9	rb16 to rb9
	4	rb24 to rb17	rb24 to rb17
	5	rb32 to rb25	rb32 to rb25
	6	rb36 to rb33	rb36 to rb33
Modified CCITT frame 2	7	rb8 to rb1	rb8 to rb1
	8	rb16 to rb9	rb16 to rb9
	9	rb24 to rb17	rb24 to rb17
	10	rb32 to rb25	rb32 to rb25
	11	rb36 to rb33	rb36 to rb33
Modified CCITT frame 3	12	rb8 to rb1	rb8 to rb1
	13	rb16 to rb9	rb16 to rb9
	14	rb24 to rb17	rb24 to rb17
	15	rb32 to rb25	rb32 to rb25
	16	rb36 to rb33	rb36 to rb33
Modified CCITT frame 4	17	rb8 to rb1	rb8 to rb1
	18	rb16 to rb9	rb16 to rb9
	19	rb24 to rb17	rb24 to rb17
	20	rb32 to rb25	rb32 to rb25
	21	rb36 to rb33	rb36 to rb33
FACCH flag	22	facch_flag	–
Rxqual_ber	23	rxqual_ber_low	–
	24	rxqual_ber_high	–

## GSM signal processing IC

## PCF5083

## 9.1.6 SYSTEM CONTROLLER INTERFACE

The PCF5083 parallel port is used for communication with the P90CL301 System Controller (SC) which is compatible with the 68000 family microcontrollers. Details about interfacing are described in Chapter 10.

The host port of the DSP has three internal registers:

1. PI; 16-bit parallel input register (write-only)
2. PO; 16-bit parallel output register (read-only)
3. PIOS; 5-bit parallel I/O Status/Control register (see Table 50).

The 16-bit words of registers PI and PO are transferred in two access cycles of 8-bits. The LOW byte/HIGH byte selection is controlled with HA0 and with bit 5 of the PIOS register, PLSB. For correct interrupt generation the transfer order should be HA1 and HA0 = 00; then HA1 and HA0 = 01 (see Table 48).

**Table 48** Host port register addressing

PLSB	HA1	HA0	DESCRIPTION	STATUS REGISTER PIOS CHANGE
0 (1)	0	0	access PI/PO HIGH (LOW) byte	no change
0 (1)	0	1	access PI/PO LOW (HIGH) byte	PISE = 0 or POSF = 0
X	1	0	reserved	no change
X	1	1	read status register PIOS	no change

**Table 49** Status/Control Register (PIOS)

7	6	5	4	3	2	1	0
–	–	–	PLSB	PORQEN	PIRQEN	POSF	PISE

**Table 50** Description of PIOS bits

BIT	NAME	DIRECTION	DESCRIPTION
7	–	–	These three bits are not used.
6	–	–	
5	–	–	
4	PLSB	read	This bit controls the parallel transfer order. When PLSB = 1; the LSB is transferred first. The reset value is a logic 1.
3	PORQEN	read/write	When PORQEN = 1; PORQN is enabled. The reset value is a logic 0.
2	PIRQEN	read/write	When PIRQEN = 1; PIRQN is enabled. The reset value is a logic 0.
1	POSF	read	When POSF = 1; the Output Register (PO) is full. The reset value is a logic 0.
0	PISE	read	When PISE = 1; the Input Register (PI) is empty. The reset value is a logic 1.

## GSM signal processing IC

## PCF5083

The host can be used in three modes:

1. **Acknowledge mode:** in this mode the PCF5083 provides an open drain output  $\overline{DTACK}$ , that acknowledges data read or write accesses to the host port registers PI, PO or PIOS. This signal has to be connected to the 90CL301  $\overline{DTACK}$  input. Using the hardware handshake via  $\overline{DTACK}$ , the 90CL301 can write data to the PI register at any time. It is not necessary to poll the PISE bit in the status register PIOS. If the 90CL301 writes to PI and PI is still full, the write access is automatically extended until the DSP has read PI. Under worst case conditions this will last 10  $\mu\text{s}$  (see formula below). Before reading a message via PO however, the System Controller has to check once if a message is available from DSP. This is done by polling the POSE flag in the PIOS register. If POSE is a logic 1 the System Controller has to read the first word of the message. After determination of the message length, the rest of the message can be read without further polling.
2. **Polling mode:** in this mode the hardware handshake via  $\overline{DTACK}$  is not used. Before writing a word to PI, the 90CL301 must wait until the PISE flag in the Status Register PIOS is set. Correspondingly, the 90CL301 must wait until the POSE flag in PIOS is set, before reading PO.
3. **Interrupt mode:** in this mode the PCF5083 provides two internal interrupt request signals PIRQN and PORQN. Signal PIRQN (active LOW) corresponds to status register bit PISE (active HIGH) and PORQN (active LOW) to bit POSF (active HIGH). As soon as the status bit PISE or POSF is set, PIRQN/PORQN is going LOW, generating an interrupt at the host. The interrupt service routines should handle the two 8-bit transfers. After the first transfer PIRQN/PORQN goes HIGH, removing the interrupt source. After the second transfer a new interrupt will be generated. PIRQN and PORQN can be enabled by setting PIOS bit 2 for PIRQ\_EN and bit 3 for PIRQ\_EN to HIGH. After reset both signals are disabled. The PIRQN and PORQN interrupt condition is signalled via the  $\overline{HIPR\_INT}$  interrupt line (see Section 10.2).

Command and indication messages are buffered in two queues, each of 139 words. If working in acknowledge mode the layer 1 software in the 90CL301 has to ensure that no queue overflow occurs (this will never happen during normal operation).

The times TPI and TPO required by the DSP to receive or transmit a message consisting of N words can be calculated according to the following formulas:

$$TPI = 10 \mu\text{s} + (N - 1) \times 1.5 \mu\text{s}$$

$$TPO = N \times 1.5 \mu\text{s}$$

Data transfer in acknowledge mode produces the least overhead in the 90CL301 layer 1 software. It is therefore recommended to use the acknowledge mode for communication with the DSP.

#### 9.1.7 EVENT COUNTER CLOCK

The event counter is used by the firmware for time-out detection. The 32.768 kHz clock is internally connected to the ECLK input of the DSP.

#### 9.1.8 GENERAL PURPOSE I/O PINS

**Table 51** Usage of General Purpose I/O Pins

PIN	RESET DEFAULT	DESCRIPTION
IO1	0	Audio interface of the timer core select pin. A logic 1 enables the interface; a logic 0 disables the interface.
IO2	1	used for procedure trace
IO3	1	used for procedure trace
IO4	1	DTX select pin. A logic 1 enables the transmitter; a logic 0 disables the transmitter.

Note that the IO1 pin is not changed automatically by the DSP firmware (e.g. by the procedure `MP_om2_enable`). Whenever audio data should be transmitted via the audio interface, IO1 has to be set explicitly by calling the procedure `DB_write_register`:

```
DB_write_register(11, 0x0100, 1) sets the IO1 bit in register SIOC
```

```
DB_write_register(11, 0x0100, 2) resets the IO1 bit in register SIOC.
```

## GSM signal processing IC

## PCF5083

## 9.1.9 POWER SAVING MODES

## 9.1.9.1 Idle mode

When operating in Idle mode the DSP enters a dormant state and requires only a fraction of the power normally needed to supply the device in the full operating mode. The processor core is switched off whereas the I/O section of the processor is fully functional. The Idle mode is invoked by the on-chip firmware whenever the DSP is waiting for an I/O event. The DSP automatically leaves the Idle mode as soon as the input or output operation has been completed.

## 9.1.9.2 Power-down mode

The Power-down mode is initiated when the signal DSPON is deactivated during Sleep mode (see Section 8.3.3). The DSP will stop operation synchronously after a maximum of 3 CLKI cycles delay. All parts of the DSP which operate with the main processor clock are in static state. Only the blocks running with the serial interface clocks are not affected by the Power-down mode. For minimum power consumption the external serial shift clocks should therefore be switched off. The DSP remains in the power-down state as long as the signal DSPON is held inactive. The processor continues its operation for a maximum of 3 clock cycles after the signal DSPON is set active again.

## 9.2 Message Interface to the System Controller

The DSP can be controlled with commands and joining 16-bits parameters from the System Controller via the host port register PI. The first word always contains the command OPCODE and length. The second word is an arbitrary ID code which is useful for debugging purposes. The following words are command parameters. The DSP can also generate indications giving status information or requested data. These indication messages can be read (R) via host port register PO.

The DMA message is used to download data into the program/data RAM. Download is always done into the data address space. The parameters mc\_before and mc\_after indicate the value of the Memory Configuration Register before and after download. Thus, it is possible to switch a RAM bank into the data address space, download a program and switch it back afterwards. For more information about the MC Register and the PCF5083 memory mapping please refer to "Information Manual Digital Signal Processors PCF508x, Philips Semiconductors, 1995".

**Table 52** Commands/indications to/from the PCF5083

MNEMONIC	DIRECTION	OPCODE <sup>(1)</sup> bit 15 to bit 8	LENGTH bit 7 to bit 0	ID	DATA
DMA	write	0X0000		msg_id	mc_before n_words; address data [1] to data [n words]; mc_after
EXEC_PROC	write	0X01	3 + npar	msg_id	proc_id; parameter_1 to parameter_N
PROC_RETURN	read	0X11	3 + n_retvals	msg_id	proc_id; return_value 1 to return value_N
PACKET	write	0X02	2 + N (cmd_len)	msg_id	cmd_1 to cmd_N
RESET	write	0X03	3	msg_id	reset_parm
NOP	write	0X05	2 + N	msg_id	data_1 to data_N
ERROR	read	0X12	3	msg_id	error_code

**Note**

1. X = don't care.

## GSM signal processing IC

## PCF5083

## 9.2.1 EXECUTION OF GSM BASEBAND PROCEDURES

The EXEC\_PROC commands initiate the execution of internal procedures. The procedure specified by proc\_id is executed within the DSP. The input parameters of the procedure are part of the message. The return values (if any) of the procedure and the msg\_id parameter are packed to a PROC\_RETURN indication.

Several commands can be combined with the PACKET command to reduce overhead especially when sending commands to the DSP in **polling mode**.

## 9.2.2 NO OPERATION (NOP) COMMAND

This NOP command may be used for debugging purposes. It is ignored by the DSP. The length of the data field has to be at least one word.

## 9.2.3 SOFT RESETTING THE DSP

The RESET command causes the DSP to perform a soft reset. It is executed immediately after the current running procedure is completed. Depending on the reset parameter (see Table 53) the input and/or output command queues are cleared. It is possible to reset more than one FIFO or queue, by setting the appropriate bits.

**Table 53** Parameter of RESET message

MNEMONIC	VALUE <sup>(1)</sup>	DESCRIPTION
RESET_ALL	0X0000	Restart main program (soft reset), clear all buffers and queues and all external memory.
OUTPUT_MESSAGE_QUEUE	0X0001	Clear the output message queue.
INPUT_MESSAGE_QUEUE	0X0002	Clear the input message queue.
BBD_IN_FIFO	0X0004	Clear the baseband digitizer input FIFO.
MOD_OUT_FIFO	0X0008	Clear the GMSK modulator output FIFO.

**Note**

1. X = don't care.

## GSM signal processing IC

## PCF5083

## 9.2.4 ERROR HANDLING

The ERROR indication notifies the SC that an error has occurred in previously submitted EXEC PROC commands with ID msg\_id. Table 54 shows all possible error codes. After the detection of an error, the current command is aborted and the DSP continues execution of the next command in the input queue.

**Table 54** Error codes

MNEMONIC	CODE	DESCRIPTION
RESET_OCCURRED	1	the DSP main program restarted
MSG_TYP_UNKNOWN	5	an undefined command was received by the DSP
WRONG_PARAMETER	10	one of the procedure parameters is not in a valid range
MSG_IN_FIFO_OVERFLOW	11	an input queue overflow occurred
MSG_OUT_FIFO_OVERFLOW	12	an output queue overflow occurred
BBD_IN_FIFO_OVERFLOW	13	a BBD FIFO overflow occurred
MOD_FIFO_FULL	14	the modulator FIFO is not empty enough to receive all data
AUDIO_IN_FIFO_OVERFLOW	15	an audio input FIFO overflow occurred
AUDIO_OUT_FIFO_UNDERFLOW	16	an audio output FIFO underflow occurred
AUDIO_OUT_FIFO_FULL	17	the audio output FIFO is not empty enough to receive all data
TIMEOUT_BBD_IN_FIFO	20	a time-out occurred waiting for BBD samples
TIMEOUT_AUDIO_IN_FIFO	21	a timeout occurred waiting for audio input samples
AUDIO_SYNC_FAILED	22	the audio synchronization was not successful
AUDIO_SYNC_TIMEOUT	26	MP_audio_sync waited too long for the first BBD sample
FSC_TIMEOUT	27	MP_iom2_enable waited too long for the frame sync interrupt
AUDIO_SAMPLES_INSERTED	28 <sup>(1)</sup>	MP_audio_sync inserted audio samples into the audio FIFO
AUDIO_SAMPLES_REMOVED	29 <sup>(1)</sup>	MP_audio_sync removed audio samples from the audio FIFO
SPEECH_ENCODER_RESET	31 <sup>(1)</sup>	a speech encoder reset occurred
SPEECH_DECODER_RESET	32 <sup>(1)</sup>	a speech decoder reset occurred

**Note**

1. These error codes do not notify a real error; they indicate the occurrence of a special event.

## GSM signal processing IC

## PCF5083

## 9.3 GSM baseband procedures

The baseband procedures with optional input parameters can be called by the EXEC\_PROC command as described in Section 9.2. Return values are packed in the PROC\_RETURN indication. Every procedure deals with the following types of data:

- Input parameters which are directly supplied by the System Controller
- Return values which are automatically sent to the System Controller as soon as the procedure is completed
- Input and output data buffers located in the DSP data RAM. They are used for communication with other procedures. Most of the procedures use a common buffer SCRATCH\_BUFF for their input and output data. Only a small number of procedures need specific buffer for input or output. In this case there are one or two additional parameters in\_buff\_id or out\_buff\_id which determine the buffers where input and output data are located. In Table 55 a list of all available buffers is given.

For all trailing parameters of a procedure which are not transmitted with the EXEC\_PROC command a default value of zero is used.

**Table 55** Data buffers for baseband procedures

MNEMONIC	ID <sup>(1)</sup>	SIZE	DESCRIPTION
VERSION_BUFF	0X8000	10	Contains the BCD coded version numbers of all software packages (order: MP, BB, CI, CM, DB, EM, FB, SP and TP). A version number 0Xmm.ss means version mm.ss.
SCRATCH_BUFF	0X8001	167	Scratch buffer for communication between arbitrary modules.
TCH_CMI_BUFF	0X8002	116	The combination of the 4 buffers; TCH_CMI_BUFF1 to TCH_CMI_BUFF4.
TCH_CMI_BUFF1	0X8003	29	Used to store the CMI values of 4 consecutive bursts belonging to one TCH block.
TCH_CMI_BUFF2	0X8004	29	
TCH_CMI_BUFF3	0X8005	29	
TCH_CMI_BUFF4	0X8006	29	
CCH_CMI_BUFF	0X8007	116	The combination of the 4 buffers; CCH_CMI_BUFF1 to CCH_CMI_BUFF4.
CCH_CMI_BUFF1	0X8008	29	Used to store the CMI values of 4 consecutive bursts belonging to one CCH block.
CCH_CMI_BUFF2	0X8009	29	
CCH_CMI_BUFF3	0X800A	29	
CCH_CMI_BUFF4	0X800B	29	
CCH_INFO_BUFF	0X800C	32	The combination of the 4 buffers; CCH_INFO_BUFF1 to CCH_INFO_BUFF4.
CCH_INFO_BUFF1	0X800D	8	Used to store the information bits 4 bursts belonging to one CCH block.
CCH_INFO_BUFF2	0X800E	8	
CCH_INFO_BUFF3	0X800F	8	
CCH_INFO_BUFF4	0X8010	8	
TCH_LOOP_BUFF	0X8011	82	Used to store four normal bursts during TCH loop-back operation. Note this buffer is also used by the speech encoder.
MP_CONTROL_BUFF	0X8013	6	Used to control several features of the firmware; see Table 56.
IQ_BUFF	0X8018	334	Used to store I and Q components from the PCF5072. This buffer is overlaid with SCRATCH_BUFF.

## Notes

1. X = don't care.

## GSM signal processing IC

## PCF5083

The MP\_CONTROL\_BUFF may be used to control several features of the DSP. It consists of 4 parameter fields as given in Tables 56 and 57.

**Table 56** Contents of MP\_CONTROL\_BUFF

OFFSET	DESCRIPTION
0	time-out_freq: ECLK input frequency divided by 10 kHz. After reset time-out_freq is set to 3 (32.768 kHz clock).
1	eclk_cycle_count: contains number of ECLK cycles spent most recently called procedure. Required for test purposes only.
2 to 4	proc_trace_buff[2]: for debugging purposes the DSP provides a procedure trace facility. The IDs of the procedures to be traced must be stored in proc_trace_buff. If any of these procedures is executing, its corresponding I/O pin (see Table 57) is set to a logic 0.

**Table 57** Associated I/O pins

LOCATION	I/O PIN	DEFAULT AFTER RESET
proc_trace_buff[0]	IO2	17 CP_rx_normal_burst
proc_trace_buff[1]	IO3	00 trace errors; note 1

**Note**

1. If proc\_trace\_buff[1] is 0, then IO3 is set on errors.



## GSM signal processing IC

## PCF5083

## 9.3.1 PROCEDURE DESCRIPTION

In this section all baseband procedures offered by the DSP are listed in alphabetical order. The following naming conventions are used throughout the description:

- Value: this is a 16-bit integer parameter (call by value) or return value (e.g. training sequence code, dtx flag)
- Value [SIZE]: this is an array consisting of SIZE 16-bit words. The array is transmitted word by word between the System Controller and the DSP (e.g. FACCH msg[12])
- Parameter names ending with buff\_id identify a buffer in the DSP data RAM where input or output data of the procedure is stored.

**Table 58** Procedure description

DESCRIPTION	ID	PARAMETERS	RETURN VALUES
<b>BB_access_burst</b> Burst building of a random access burst in accordance with "GSM Rec. 05.02". The burst information bits must be located in SCRATCH_BUFF. The result is returned in SCRATCH_BUFF.	1	–	–
<b>BB_normal_burst</b> Burst building of n_bursts normal bursts in accordance with "GSM Rec. 05.02". The burst information bits must be located in the buffer determined by info_buff_id. The result is returned in buffer burst_buff_id. 'tsc' is the training sequence code (range: 0 to 7)	2	info_buff_id burst_buff_id tsc n_bursts	–
<b>CI_decrypt</b> (note 1) Decryption of the CMI values of n_bursts bursts stored in buffer cmi_buff_id. Note that n_bursts may be in the range from 1 to 4. If n_bursts is set to 4, cmi_buff_id <b>must not</b> be any other than TCH_CMI_BUFF or CCH_CMI_BUFF	3	cmi_buff_id n_bursts	–

## GSM signal processing IC

## PCF5083

DESCRIPTION	ID	PARAMETERS	RETURN VALUES
<p><b>CI_decrypt_init</b> (note 1)</p> <p>Initialization for CI_decrypt. The decrypt_flag enables or disables decryption.</p> <p>decrypt_flag = 0, means no decryption.            decrypt_flag = 1, decryption according to A5/1.            decrypt_flag = 2, decryption according to A5/2</p> <p>t1 is absolute Frame Number (FN) divisor <math>26 \times 51</math> (0 to 2047, 11 bits).            t2 is absolute Frame Number (FN) modulo 26 (0 to 25, 5 bits)            t3 is absolute Frame Number (FN) modulo 51 (0 to 50, 6 bits)</p> <p>key[0 to 3] contains 64 bits of the ciphering key <math>K_c</math> in accordance with "GSM Rec. 03.20". The bits are loaded by the algorithm in LSB first order (first bit = LSB {key[0]}, last bit = MSB {key[3]}).</p> <p>The A8 algorithm delivers 8 bytes kc[0] to kc[7]. The mapping between kc and key is as follows:</p> <p>key[0] = kc[6] &lt;&lt; 8; kc[7]            key[1] = kc[4] &lt;&lt; 8; kc[5]            key[2] = kc[2] &lt;&lt; 8; kc[3]            key[3] = kc[0] &lt;&lt; 8; kc[1]</p>	4	decrypt_flag t1 t2 t3 key[4]	–
<p><b>CI_encrypt</b></p> <p>Encryption of n_bursts normal bursts, info_buff_id determines the buffer where the information bits of the first burst are stored.</p>	5	info_buff_id n_bursts	–
<p><b>CI_encrypt_init</b></p> <p>Initialization for CI_encrypt. The encrypt_flag enables or disables encryption.</p> <p>decrypt_flag = 0, means no encryption.            decrypt_flag = 1, encryption according to A5/1.            decrypt_flag = 2, encryption according to A5/2.</p> <p>t1 is absolute Frame Number (FN) divisor <math>26 \times 51</math> (0 to 2047, 11 bits).            t2 is absolute Frame Number (FN) modulo 26 (0 to 25, 5 bits)            t3 is absolute Frame Number (FN) modulo 51 (0 to 50, 6 bits)</p> <p>Key[0 to 3] contains 64 bits of the ciphering key <math>K_c</math> in accordance with "GSM Rec. 03.20". The bits are loaded by the algorithm in LSB first order (first bit = LSB {key[0]}, last bit = MSB {key[3]}).</p> <p>The A8 algorithm delivers 8 bytes kc[0] to kc[7]. The mapping between kc and key is as follows:</p> <p>key[0] = kc[6] &lt;&lt; 8; kc[7]            key[1] = kc[4] &lt;&lt; 8; kc[5]            key[2] = kc[2] &lt;&lt; 8; kc[3]            key[3] = kc[0] &lt;&lt; 8; kc[1]</p>	6	encrypt_flag t1 t2 t3 key[4]	–

## GSM signal processing IC

## PCF5083

DESCRIPTION	ID	PARAMETERS	RETURN VALUES
<p><b>CM_convert_TCHFS_data</b></p> <p>This routine is used for the TCH/FS loop-back. It converts the output data of CM_decoder_TCHFS into a format which is required for CM_encoder_TCHS.</p> <p>If bfi_sig_flag is set to logic 1, then the decoded speech parameters are set to zero if a bad frame has been detected.</p>	7	bfi_sig_flag	–
<p><b>CM_decoder_CCH</b></p> <p>Channel decoder for control channels. In accordance with "GSM Rec. 05.03" this procedure can be used for the following channels:</p> <p>BCCH: Broadcast Control Channel  PCH: Paging Channel  SACCH: Slow Associated Control Channel  AGCH: Access Grant Channel  SDCCH: Stand-alone Dedicated Control Channel.</p> <p>The four bursts containing CCH information which are stored in CCH_CMI_BUFF are decoded</p> <p>rxqual_ber reflects the estimated bit error rate at the input of the channel decoder (hard decision assumed) multiplied by 4096.</p> <p>bfi_cch bad frame indication:</p> <p>bfi_cch = 0; the decoded CCH message is OK  bfi_cch = 1; a parity error has been detected  bfi_cch = 2; a bad metric error has been detected  bfi_cch = 3; both parity <b>and</b> bad metric errors have been detected.</p> <p>cch_msg[12] contains the CCH message consisting of 184 bits. The bits are stored in a packed format with 16-bits per word and LSB first order. Unused MSBs are set to zero.</p>	8	–	rxqual_ber bfi_cch cch_msg[12]
<p><b>CM_decoder_SCH</b></p> <p>Channel decoder synchronization channel.</p> <p>bfi_sch is the bad frame indication:</p> <p>bfi_sch = 0; the decoded SCH message is OK  bfi_sch = 1; a parity error has been detected  bfi_sch = 2; a bad metric error has been detected  bfi_sch = 3; both parity <b>and</b> bad metric errors have been detected.</p> <p>sch_msg[2] contains the decoded SCH message consisting of 25 bits. The bits are stored in a packed format with 16-bits per word and LSB first order. Unused bits are set to zero.</p>	9	–	bfi_sch sch_msg[2]

## GSM signal processing IC

## PCF5083

DESCRIPTION	ID	PARAMETERS	RETURN VALUES
<p><b>CM_decoder_TCHDATA</b></p> <p>Channel decoder and de-interleaver for data channels and FACCH in accordance with "GSM Rec. 05.03". The CMI values located in TCH_CMI_BUFF are decoded. The decoded bits are stored in SCRATCH_BUFF. The data channel decoder is selected by the call of CM_DECODER_TCHDATA_INIT.</p> <p>rxqual_ber (format 16-bit integer) reflects the estimated bit error rate at the input of the channel decoder (hard decision assumed) multiplied by 4096.</p> <p>bfi_facch is the bad frame indication:</p> <p>bfi_facch = 0; the decoded FACCH message is OK  bfi_facch = 1; a parity error has been detected  bfi_facch = 2; a bad metric error has been detected  bfi_facch = 3; both parity <b>and</b> bad metric errors have been detected.</p> <p>The facch_flag indications:</p> <p>facch_flag = 0; indicates that no FACCH message has been received. In this case facch_msg[12] contains zeros.  facch_flag = 1; indicates that a FACCH message has been decoded and is returned into facch_msg[12].</p> <p>The facch_msg[12] contains the 184 bits of the decoded FACCH message. The bits are stored in a packed format with 16-bits per word and LSB first order. Unused MSBs are set to zero.</p>	72	–	rxqual_ber bfi_facch facch_flag facch_msg[12]
<p><b>CM_decoder_TCHDATA_init</b></p> <p>Initialization of the CM_decoder_TCHDATA.</p> <p>The parameter data_service may be one of the following values:</p> <p>data_service = 0; full-rate = 9.6 kbits/s  data_service = 1; full-rate = 4.8 kbits/s  data_service = 2; full-rate ≤ 2.4 kbits/s  data_service = 3; half-rate = 4.8 kbits/s  data_service = 4; half-rate ≤ 2.4 kbits/s.</p>	73	data_service	–

## GSM signal processing IC

## PCF5083

DESCRIPTION	ID	PARAMETERS	RETURN VALUES
<p><b>CM_decoder_TCHFS</b></p> <p>Channel decoder and de-interleaver for the full-rate speech traffic channel and FACCH in accordance with "GSM Rec. 05.03". The CMI values located in TCH_CMI_BUFF are decoded. The decoded bits are stored in SCRATCH_BUFF.</p> <p>rxqual_ber (format 16-bit integer) reflects the estimated bit error rate at the input of the channel decoder (hard decision assumed) multiplied by 4096.</p> <p>bfi_facch is the bad frame indication:</p> <p>bfi_facch = 0; the decoded FACCH message is OK  bfi_facch = 1; a parity error has been detected  bfi_facch = 2; a bad metric error has been detected  bfi_facch = 3; both parity <b>and</b> bad metric errors have been detected.</p> <p>The facch_flag indications:</p> <p>facch_flag = 0; indicates that no FACCH message has been received. In this event facch_msg[12] contains zeros  facch_flag = 1; indicates that a FACCH message has been decoded and is returned into facch_msg[12].</p> <p>The facch_msg[12] contains the 184 bits of the decoded FACCH message. The bits are stored in a packed format with 16-bits per word and LSB first order. Unused MSB's are set to zero.</p>	10	–	rxqual_ber bfi_facch facch_flag facch_msg[12]
<p><b>CM_decoder_TCHFS_init</b></p> <p>Initialization of CM_decoder_TCHFS.</p>	11	–	–
<p><b>CM_encoder_CCH</b></p> <p>Channel decoder for control channels. In accordance with "GSM Rec. 05.03" this procedure can be used for the following channels:</p> <p>SACCH: Slow Associated Control Channel  SDCCH: Stand-alone Dedicated Control Channel.</p> <p>The encoded data is stored in CCH_INFO_BUFF.</p> <p>The cch_msg[12] contains the 184 bits of the decoded CCH message. The bits are stored in a packed format with 16-bits per word and LSB first order. Unused MSB's are set to zero.</p>	12	cch_msg[12]	–

## GSM signal processing IC

## PCF5083

DESCRIPTION	ID	PARAMETERS	RETURN VALUES
<p><b>CM_encoder_RACH</b></p> <p>Channel encoder random access channel. The encoded RACH message is stored in SCRATCH_BUFF.</p> <p>bsic contains the 6 bits B(0) to B(5) of the base station identity code in accordance with "GSM Rec. 05.03". B(0) is stored in the LSB (bit 0) of bsic, B(5) in bit 5 of bsic. B(0) = MSB of PLMN colour code, B(5) = LSB of BS colour code.</p> <p>rach_msg[1] contains the RACH message consisting out of 8 bits. The bits are stored in LSB first order. Unused MSBs are set to zero.</p>	13	bsic rach_msg[1]	–
<p><b>CM_encoder_TCHDATA</b></p> <p>Channel encoder and interleaver for data channels, FACCH and DTX uplink control.</p> <p>The dtx_flag determines whether discontinuous transmission (DTX) is applied:</p> <p>dtx_flag = 1; DTX is applied dtx_flag = 0; DTX is not applied.</p> <p>DTX is valid only for the encoder for full-rate 9.6 kbits/s and half-rate 4.8 kbits/s.</p> <p>The facch_flag indications:</p> <p>facch_flag = 0; indicates that no FACCH data must be encoded facch_flag = 1; indicates that a FACCH message must be encoded.</p> <p>The facch_msg[12] contains the 184 bits of the FACCH message. The bits are stored in a packed format with 16-bits per word and LSB first order.</p> <p>The return value txen is only useful if DTX is applied. It indicates whether the TCH block will be transmitted over the air interface.</p> <p>txen = 1; TCH block will be transmitted over the air interface txen = 0; TCH block will not be transmitted over the air interface.</p> <p>For data services other than full-rate 9.6 kbits/s and half-rate 4.8 kbits/s txen will be set to logic 1.</p>	74	dtx_flag facch_flag facch_msg[12]	txen
<p><b>CM_encoder_TCHDATA_init</b></p> <p>Initialization of CM_ENCODER_TCHDATA. The parameter data_service may be one of the following values:</p> <p>data_service = 0; full-rate = 9.6 kbits/s data_service = 1; full-rate = 4.8 kbits/s data_service = 2; full-rate ≤ 2.4 kbits/s data_service = 3; half-rate = 4.8 kbits/s data_service = 4; half-rate ≤ 2.4 kbits/s.</p>	75	data_service	–

## GSM signal processing IC

## PCF5083

DESCRIPTION	ID	PARAMETERS	RETURN VALUES
<p><b>CM_encoder_TCHFS</b></p> <p>Channel encoder and interleaver for traffic channel full-rate speech and FACCH and DTX uplink control.</p> <p>The <code>dtx_flag</code> determines whether discontinuous transmission (DTX) is applied:</p> <p><code>dtx_flag = 1</code>; DTX is applied  <code>dtx_flag = 0</code>; DTX is not applied.</p> <p>The <code>taf</code> determines whether the current traffic frame is aligned with the SACCH multiframe structure as described in "GSM Rec. 05.08":</p> <p><code>taf = 0</code>; not aligned with SACCH multiframe structure  <code>taf = 1</code>; aligned with SACCH multiframe structure.</p> <p>The <code>facch_flag</code> indications:</p> <p><code>facch_flag = 0</code>; indicates that no FACCH message need be encoded  <code>facch_flag = 1</code>; indicates that a FACCH message must be encoded.</p> <p>The <code>facch_msg[12]</code> contains the 184 bits of the FACCH message. The bits are stored in a packed format with 16-bits per word and LSB first order.</p> <p>The return value <code>txen</code> is only useful if DTX is applied. It indicates whether the TCH block will be transmitted over the air interface.</p> <p><code>txen = 1</code>; TCH block will be transmitted over the air interface  <code>txen = 0</code>; TCH block will not be transmitted over the air interface.</p>	14	<code>dtx_flag</code> <code>taf</code> <code>facch_flag</code> <code>facch_msg[12]</code>	<code>txen</code>
<p><b>CM_encoder_TCHFS_init</b></p> <p>Initialization of <code>CM_encoder_TCHFS</code>.</p>	15	–	–
<p><b>CP_audio_loop</b></p> <p>Combination of:  <code>MP_READ_AUDIO_IN_FIFO (SCRATCH_BUFF, 160, -1)</code>;  <code>MP_WRITE_AUDIO_OUT_FIFO (SCRATCH_BUFF, 160)</code>.</p>	16	–	–
<p><b>CP_freq_estim</b></p> <p>Combination of:  <code>MP_READ_BBD_IN_FIFO (IQ_BUFF, 167)</code>;  <code>FB_FREQ_ESTIM (threshold)</code></p> <p>The <code>fb_freq_estim</code> processes 156 I and Q samples only. 167 samples are read in order to minimize the number of different burst length</p>	81	<code>threshold</code>	<code>fb_qual</code> <code>fb_foi</code>
<p><b>CP_freq_estim_offset (PCF5083-3)</b></p> <p>Combination of:  <code>MP_READ_BBD_IN_FIFO_INIT (i_offset, q_offset)</code>;  <code>MP_READ_BBD_IN_INFO (IQ_BUFF, 167)</code>;  <code>FB_FREQ_ESTIM (threshold)</code>.</p>	37	<code>threshold</code> <code>i_offset</code> <code>q_offset</code>	<code>fb_qual</code> <code>fb_foi</code>

## GSM signal processing IC

## PCF5083

DESCRIPTION	ID	PARAMETERS	RETURN VALUES
<b>CP_power measure</b> Combination of: MP_READ_BBD_IN_FIFO (IQ_BUFF, 80); EM_POWER_MEASUREMENT (agc_gain1).	19	agc_gain1	power1
<b>CP_power-measure_offset (PCF5083-3)</b> Combination of: MP_READ_BBD_IN_FIFO (i_offset, q_offset); MP_READ_BBD_IN_INFO (IQ_BUFF, 80) EM_POWER_MEASUREMENT (agc_gain1).	20	agc_gain1 i_offset q_offset	power1
<b>CP_regenerate_tone_gen</b> Combination of: MP_READ_AUDIO_IN_FIFO (SCRATCH_BUFF, 160, 0XFFFF); DB_FILL_BUFFER (SCRATCH_BUFF, 0, 0X0000, 160); TG_TONE_GEN ( ); MP_WRITE_AUDIO_OUT (SCRATCH_BUFF, 160).	64	–	–
<b>CP_rx_normal_burst</b> Combination of: MP_READ_BBD_IN_FIFO (SCRATCH_BUFF, 149); EM_POWER_MEASUREMENT(agc_gain); EM_NORMAL_BURST (tch_cmi_buff_id, tsc); CI_DECRYPT (tch_cmi_buff_id, 1).	17	tch_cmi_buff tsc agc_gain	power snr toi foi_re foi_im
<b>CP_rx_normal_burst_offset (PCF5083-3)</b> Combination of: MP_READ_BBD_IN_FIFO (i_offset, q_offset); MP_READ_BBD_IN_FIFO (SCRATCH_BUFF, 149); EM_POWER_MEASUREMENT(agc_gain); EM_NORMAL_BURST (tch_cmi_buff_id, tsc); CI_DECRYPT (tch_cmi_buff_id, 1).	38	tch_cmi_buff tsc agc_gain i_offset q_offset	power snr toi foi_re foi_im
<b>CP_rx_SCH</b> Combination of: MP_READ_BBD_IN_FIFO (IQ_BUFF, 167); EM_SYNC_BURST( ); CM_DECODER_SCH( ).	55	–	snr toi foi_re foi_im bfi_sch sch_msg[12]



## GSM signal processing IC

## PCF5083

DESCRIPTION	ID	PARAMETERS	RETURN VALUES
<b>CP_rx_SCH_offset (PCF5083-3)</b> Combination of: MP_READ_BBD_IN_FIFO (i_offset, q_offset); MP_READ_BBD_IN_FIFO (IQ_BUFF, 167); EM_SYNC_BURST(); CM_DECODER_SCH().	39	i_offset q_offset	snr toi foi_re foi_im bfi_sch sch_msg[12]
<b>CP_rx_speech</b> Combination of: CM_DECODER_TCHFS(); TG_TONE_GEN(); SP_DECODER_TCHFS (dtx_flag, taf, test_mode); MP_WRITE_AUDIO_OUT_FIFO (SCRATCH_BUFF, 160).	18	dtx_flag taf test_mode	rxqual_ber bfi_facch facch_flag facch_msg[12]
<b>CP_rxlev2 (only in versions PCF5083-1 and PCF5083-2)</b> Combination of: MP_READ_BBD_IN_FIFO (IQ_BUFF, 80); EM_POWER_MEASUREMENT(agc_gain1); MP_READ_BBD_IN_FIFO (IQ_BUFF, 80); EM_POWER_MEASUREMENT(agc_gain2).	20	agc_gain1 agc_gain2	power1 power2
<b>CP_rxlev3 (only in versions PCF5083-1 and PCF5083-2)</b> Combination of: MP_READ_BBD_IN_FIFO (IQ_BUFF, 80); EM_POWER_MEASUREMENT(agc_gain1); MP_READ_BBD_IN_FIFO (IQ_BUFF, 80); EM_POWER_MEASUREMENT(agc_gain2); MP_READ_BBD_IN_FIFO (IQ_BUFF, 80); EM_POWER_MEASUREMENT(agc_gain3).	21	agc_gain1 agc_gain2 agc_gain3	power1 power2 power3
<b>CP_search_fcb_offset (PCF5083-3)</b> Combination of: MP_READ_BBD_IN_FIFO (i_offset, q_offset); FB_search_fcb().	21	i_offset q_offset	fb_found fb_toi fb_index
<b>CP_start_TCHFS</b> Combination of: CI_ENCRYPT_INIT (enc_flag, t1, t2, t3, key[4]); CI_DECRYPT_INIT (enc_flag, t1, t2, t3, key[4]); SP_ENCODER_TCHFS_INIT(); SP_DECODER_TCHFS_INIT(); CM_ENCODER_TCHFS_INIT(); CM_DECODER_TCHFS_INIT(); CI_ENCRYPT (SCRATCH_BUFF, nb); BB_NORMAL_BURST (SCRATCH_BUFF, SCRATCH_BUFF, tsc, nb); MP_IOM2_ENABLE(); MP_AUDIO_SYNC (tch_frame_no, slip, delta_rx_delay, delta_tx_delay); MP_WRITE_NORMAL_BURST (SCRATCH_BUFF, nb).	78	enc_flag dec_flag t1 t2 t3 key[4] nb tsc slip delta_rx_delay delta_tx_delay	–

## GSM signal processing IC

## PCF5083

DESCRIPTION	ID	PARAMETERS	RETURN VALUES
<b>CP_tx_CCH</b> Combination of: CM_ENCODER_CCH (cch_msg); CI_ENCRYPT (CCH_INFO_BUFF, 4); BB_NORMAL_BURST (CCH_INFO_BUFF, SCRATCH_BUFF, tsc, 4); MP_WRITE_MOD_OUT_FIFO (SCRATCH_BUFF, 44).	23	tsc cch_msg[12]	–
<b>CP_tx_four_normal_bursts</b> Combination of: CI_ENCRYPT (SCRATCH_BUFF, 4); BB_NORMAL_BURST (SCRATCH_BUFF, SCRATCH_BUFF, tsc, 4); MP_WRITE_MOD_OUT_FIFO (SCRATCH_BUFF, 44).	43	tsc	–
<b>CP_tx_normal_burst</b> Combination of: CI_ENCRYPT (info_buff_id, 1); BB_NORMAL_BURST (SCRATCH_BUFF, SCRATCH_BUFF, tsc, 1); MP_WRITE_MOD_OUT_FIFO (SCRATCH_BUFF, 11).	24	info_buff_id tsc	–
<b>CP_tx_RACH</b> Combination of: CM_ENCODER_RACH (bsic, rach_msg); BB_ACCESS_BURST(); MP_WRITE_MOD_OUT_FIFO (SCRATCH_BUFF, 11).	25	bsic rach_msg	–
<b>CP_tx_speech</b> Combination of: MP_READ_AUDIO_IN_FIFO (SCRATCH_BUFF, 160, 11); SP_ENCODER_TCHFS (dtx_flag, bypass_flag, test_mode); CM_ENCODER_TCHFS (dtx_flag, taf, facch_flag, facch_msg); CI_ENCRYPT (SCRATCH_BUFF, 4); BB_NORMAL_BURST (SCRATCH_BUFF, SCRATCH_BUFF, tsc, 4); MP_WRITE_MOD_OUT_FIFO (SCRATCH_BUFF, 44).	26	dtx_flag bypass_flag test_mode taf tsc facch_flag facch_msg[12]	txen
<b>DB_call</b> This procedure calls a procedure located at program address proc_addr.	30	proc_addr	–

## GSM signal processing IC

## PCF5083

DESCRIPTION	ID	PARAMETERS	RETURN VALUES
<p><b>DB_copy_buffer</b></p> <p>n_words words are copied within DSP data RAM</p>	27	source_buff_id dest_buff_id source_offset dest_offset n_words	–
<p><b>DB_compare_info_cmi</b></p> <p>This procedure may be used to measure bit errors in a received burst. It compares the first n_bits soft outputs (CMIs) of the equalizer located in cmi_buff to the n_bits hard bits located in buffer info_buffer_id and returns the number of errors found (n_errors).</p>	71	info_buff_ptr cmi_buff_ptr n_bits	n_errors
<p><b>DB_fill_buffer</b></p> <p>n_words words are filled with fill_value.</p>	28	buff_id buff_offset fill_value n_words	–
<p><b>DB_pio_test</b></p> <p>This procedure can be used to test data transfer between the 90CL301 and the PCF5083. With every call, <b>DB_pio_test</b> checks if the parameters in_seq[0 to 4] are equal to the following predefined sequences of numbers:</p> <p>in_seq[0] = k × 3 in_seq[1] = k × 5 in_seq[2] = k × 7 in_seq[3] = k × 9 in_seq[4] = k × 11.</p> <p>Where k indicates how often <b>DB_pio_test</b> has been previously called (e.g. k = 0 for the first call after reset).</p> <p>The return value n_errors indicates the number of errors found in in_seq[0 to 4] (range 0 to 4). In addition the following predefined output sequences are returned:</p> <p>out_seq[0] = k × 11 out_seq[1] = k × 9 out_seq[2] = k × 7 out_seq[3] = k × 5 out_seq[4] = k × 3.</p>	70	in_seq [0 to 4]	out_seq [0 to 4] n_errors
<p><b>DB_read_buffer</b></p> <p>The n_words are read from buffer buff_id starting at offset buff_offset; n_words must not be greater than 19.</p>	29	buff_id buff_offset n_words	buff[n_words]

## GSM signal processing IC

## PCF5083

DESCRIPTION	ID	PARAMETERS	RETURN VALUES
<p><b>DB_read_register</b></p> <p>This function may be used to read the contents of a control or shadow register of the DSP. If reg_number is out-of-range, the function returns an error, ERROR_WRONG_PARAMETER. The registers that may be read are given in Table 59</p>	61	reg_number	reg_contents
<p><b>DB_wait</b></p> <p>Wait for cycles ECLK cycles.</p>	56	cycles	–
<p><b>DB_write_buffer</b></p> <p>n_words are written into buffer buff_id starting at offset buff_offset; n_words must not be greater than 17.</p>	32	buff_id buff_offset n_words data[n_words]	–
<p><b>DB_write_register</b></p> <p>This function may be used to write a control or shadow register of the DSP.</p> <p>Dependent on the input parameter action the register reg_number is written with value or the value is interpreted as a mask to set or to clear only specific bits. The procedure disables the interrupts to make sure that nobody else can change the registers. If reg_number is out-of-range or if an attempt is made to set or clear bits in a register, that is only writeable, the function returns an error (ERROR_WRONG_PARAMETER). The registers that may be changed are given in Table 60.</p> <p>The action parameter may be one of following values:</p> <p>action = 0; write register (reg = value) action = 1; set bits (reg ≠ value) action = 2; clear bits (reg ≠ ~value).</p>	62	reg_number value action	–
<p><b>EM_init</b></p> <p>This procedure sets the output mode for EM_normal_burst and EM_sync_burst. The output_mode values are defined below:</p> <p>output_mode = 0; the 4th return value contains the frequency offset df, in Hz. output_mode = 1 (default after reset); the 4th return value contains the imaginary part of the frequency offset df.</p>	82	output_mode	–

GSM signal processing IC

PCF5083

DESCRIPTION	ID	PARAMETERS	RETURN VALUES
<p><b>EM_normal_burst</b></p> <p>Adaptive viterbi equalizer for normal bursts. The 149 I and Q pairs in IQ_BUFF are demodulated. The parameter cmi_buff_id determines the buffer where the demodulated CMI values should be stored. The following values for cmi_buff_id are allowed:</p> <p>TCH_CMI_BUFFx for sub-block number x of a TCH. CCH_CMI_BUFFx for sub-block number x of a CCH.</p> <p>The parameter tsc determines the training sequence code. Valid range: <math>0 \leq tsc \leq 7</math>.</p> <p>The snr is an estimation for the signal-to-noise ratio (<math>0 \leq snr \leq 255</math>).</p> <p>The toi denotes the measured time difference (in quarterbits) between the first information bit of the burst and the start of the sampling window. Range: <math>0 \leq toi \leq 28</math>. A toi value of 12 is the optimal position.</p> <p>For output_mode = 1; (see EM_init) foi_re and foi_im denote the real and imaginary part of the frequency offset information. The frequency offset df (Hz) can be calculated in accordance with equation:</p> $f_{df} = \frac{foi_{im}}{foi_{re} \times 663}$ <p>For output_mode = 0; the frequency offset df in Hz is returned instead of foi_im as the 4th return values.</p> <p>It should be noted that the frequency offset output (for both output modes) only contains meaningful information, if foi_re &gt; 450.</p>	34	cmi_buff_id tsc	snr toi foi_re foi_im df
<p><b>EM_offset_measurement</b></p> <p>This procedure measures the offset of the complex baseband signal located in IQ_BUFF.</p> <p>The parameter n_samples is the number of complex I and Q samples to be used for averaging; n_samples must be one of the following values: 64 or 128. If n_samples is not specified, then a default value of 128 is used.</p> <p>The i_offset and q_offset is the time averaged value of the complex baseband signal.</p>	79	[n_samples]	i_offset q_offset
<p><b>EM_power_measurement</b></p> <p>Power measurement for RXLEV calculation of serving and neighbouring cells.</p> <p>The agc_gain is the gain of the current AGC range in <math>\frac{1}{8}</math> dB.</p> <p>The parameter n_samples is the number of I and Q samples located in IQ_BUFF to be used for averaging; n_samples must be one of the following values: 80 or 144. If the parameter n_samples is not specified, then a default value of 80 is used.</p> <p>The power_dBm is the time averaged value of the complex baseband signal in <math>\frac{1}{8}</math> dBm steps (range: <math>-722+agc\_gain</math> to <math>agc\_gain</math>).</p>	35	agc_gain [n_samples]	power_dB

## GSM signal processing IC

## PCF5083

DESCRIPTION	ID	PARAMETERS	RETURN VALUES
<p><b>EM_sync_burst</b></p> <p>Adaptive viterbi equalizer for synchronization bursts. The 167 I and Q pairs in IQ_BUFF are demodulated. The demodulated CMI values are also stored in SCRATCH_BUFF.</p> <p>snr is an estimation for the signal-to-noise ratio (<math>0 \leq \text{snr} \leq 255</math>)</p> <p>The toi denotes the measured time difference (in quarterbits) between the first information bit of the burst and the start of the sampling window. Range: <math>0 \leq \text{toi} \leq 96</math>. A toi value of 46 is the optimal position.</p> <p>The foi_re and foi_im denote the real and imaginary part of the frequency offset information. The frequency offset df (Hz) can be calculated in accordance with equation:</p> $f_{df} = \frac{\text{foi\_im}}{\text{foi\_re} \times 663}$	36	–	snr toi foi_re foi_im
<p><b>FB_freq_estim</b></p> <p>This procedure performs a frequency measurement by analysing the phase of the 156 IQ samples located in IQ_BUFF.</p> <p>The parameter threshold is the frequency estimation reliability threshold. If it is not specified a default value of 3 will be used.</p> <p>fb_qual = 0; indicates that no FCB has been detected, fb_qual &gt; 0 means that an FCB has been found. The fb_qual may be used as reliability information.</p> <p>The return value fb_foi is the measured frequency offset information in Hertz. fb_foi = received frequency – frequency of local oscillator.</p>	66	[threshold]	fb_qual fb_foi
<p><b>FB_freq_estim_init</b></p> <p>This routine initialises all internal counters that are used for averaging by FB_freq_estim and FB_estim_eval. It is not necessary to call FB_freq_estim if averaging via FB_freq_estim_eval is not required.</p>	65	–	–
<p><b>FB_freq_estim_eval</b></p> <p>The procedure performs a weighted averaging over all previous results of FB_freq_estim.</p> <p>The parameter threshold is the frequency estimation reliability threshold (recommended value: tbf).</p> <p>fb_flag = 0 indicates that no FCBs have been detected. fb_flag = 1 indicates that at least one FCB has been detected.</p> <p>The return value fb_foi is the measured frequency offset information in Hertz. fb_foi = received frequency – frequency of local oscillator.</p>	67	threshold	fb_flag fb_foi

## GSM signal processing IC

## PCF5083

DESCRIPTION	ID	PARAMETERS	RETURN VALUES
<p><b>FB_search_fcb</b></p> <p>This procedure searches for a frequency correction burst (FB) by scanning 9 or more timeslots. FB_search_fcb can be used on 26 or 51-frames multiframe structure. When serving a traffic channel (TCH) the BCCH carrier has to be scanned in the IDLE frames of the 26 multiframe structure using search windows of 9 timeslots. After initialization with FB_search_fcb_init (see below), FB_search_fcb has to be called in up to 11 consecutive IDLE frames. This time period is called an observation interval, containing at least one FB.</p> <p>The 51 multiframe structure is used in cell selection or IDLE mode and on an SDDCH. If search windows of 9 timeslots are used to scan the BCCh carrier, the search must be done by 15 successive calls to FB_search_fcb within the following TDMA frames (N denotes the arbitrary TDMA frame number of the first call):</p> <p>N, N+2, N+4, N+6, N+8, N+11, N+13, N+15, N+17, N+19, N+22, N+24, N+26, N+28, N+30.</p> <p>If the search window is extended to 17 timeslots, the search can be done by 7 calls at the frames:</p> <p>N, N+3, N+6, N+9, N+12, N+15, N+18.</p> <p>Values of fb_found are defined below:</p> <p>fb_found = -1; the search has been aborted and no FCB has been found. fb_found = 0; no FB has been found up to now, FB_search_fcb should be called again in the next Idle frame. fb_found = &gt; 0; the search has been successful. fb_found FBs have been found within n_obser_int observation intervals.</p> <p>The return value fb_toi is the start of the FB in bits (1 bit = 3.69 μs) relative to first complex sample of the observation window.</p> <p>The fb_index indicates in which of the previous calls to FB_search_fcb the FB has been actually found. If fb_index is zero, then the FB has been found by fast detection during the current search. The fb_index = -1 means that no FB has been found within the current observation interval, if this is combined with fb_found &gt; 0 the call cannot be located and only fb_toi can be used.</p>	39	-	fb_found fb_toi fb_index

## GSM signal processing IC

## PCF5083

DESCRIPTION	ID	PARAMETERS	RETURN VALUES
<p><b>FB_search_fcb_init</b></p> <p>Initialization of FB_search_fcb. This routine has to be called before a new FB search is started. The following parameters are recommended:</p> <p>The parameter len_obser_int indicates how many observation windows belong to an observation interval. The parameter len_obser_int must be set to 11 for a 26-frames and to 15 (or 7) for 51-frames multiframe structure. If the parameter len_obser_int is omitted or set to zero, all successive calls of FB_search_fcb perform only fast FB detection.</p> <p>The FB search algorithm includes a match filter for FB detection. The output of this matched filter is compared with the parameter threshold in order to decide whether an FB has been found or not. If the parameter threshold is omitted (or set to zero respectively) the recommended default value of 400 is used.</p> <p>The parameter hi_threshold is used to perform a fast FB detection under good channel conditions. If the matched filter output exceeds hi_threshold, the FB search is terminated immediately. If hi_threshold is not specified, a default value of 667 is used.</p> <p>The parameter n_samples indicates the length of a search window in bits, i.e. the number of IQ samples. If n_samples is not specified, a default value of 1404 bits is used, corresponding to 9 timeslots.</p> <p>The parameter n_obser_int indicates the number of observation intervals to be used. If the n_obser_int is not specified, a default value of 1 is used.</p>	68	len_obser_int [threshold] [hi_threshold] [n_timeslots] [n_samples] [n_obser_int]	–
<p><b>MP_audio_sync</b></p> <p>To start speech procedures in a regular way in full rate traffic channel mode the speech frame timing has to be locked to the TDMA frame timing. Each time a traffic channel is established or switched over (e.g. handover), a new synchronization has to be performed.</p> <p>MP_AUDIO_SYNC has to be started before the receive time slot. The procedure synchronises speech and TDMA frame timing by waiting for the first I and Q pair coming from the BBD and then immediately sets the pointers of audio input and output FIFOs.</p> <p>The parameter slip is normally set to zero indicating that an audio synchronization should be performed. If slip is not equal to zero (valid range 1 to 5), it is checked whether the audio frame timing is still locked to the TDMA frame timing. If the deviation exceeds slip audio samples (125 µs) a resynchronization is performed.</p> <p>The parameter tch_frame_no has to be set to (<b>fn mod 26</b>) where fn is the TDMA frame number of the first TDMA frame of the TCH block.</p> <p>The parameters delta_rx_delay and delta_tx_delay are normally set to zero. They may be used to increase or decrease the speech delay in receive and transmit path in 125 µs units, e.g. delta_rx_delay = 1 increases the delay in the RX path by 125 µs. Valid range for delta_rx_delay and delta_tx_delay is –10 to +10. Note that MP_iom2_enable must be called beforehand.</p>	41	tch_frame_no slip delta_rx_delay delta_tx_delay	–



## GSM signal processing IC

## PCF5083

DESCRIPTION	ID	PARAMETERS	RETURN VALUES
<p><b>MP_convert_cmi</b></p> <p>This procedure may be used to make a loopback between equalizer output and burst builder input. It converts the 114 soft outputs (CMIs) of the equalizer located in <code>cmi_buff_id</code> into 114 'hard' bits. These bits are stored in buffer <code>info_buff_id</code>.</p>	22	<code>cmi_buff_id</code> <code>info_buff_id</code>	–
<p><b>MP_exec_reset</b></p> <p>This procedure is used to execute a reset synchronous to the input message queue. The difference to the RESET message is, that this procedure is not executed immediately after it is found in the input queue. The <code>reset_action</code> is the same as the one of the RESET message.</p>	60	<code>reset_action</code>	–
<p><b>MP_if_enough_audio_in_samples</b></p> <p>This procedure is used for conditional execution of procedures. The following <code>n_procs</code> procedures are executed if the audio input FIFO contains at least <code>n_samples</code> samples, otherwise the procedures are skipped.</p>	42	<code>n_samples</code> <code>n_procs</code>	–
<p><b>MP_iom2_disable</b></p> <p>This procedure disables the IOM<sup>®</sup>-2 interrupts of the DSP. This results in a reduced computational load of the DSP and therefore also in reduced power consumption.</p>	44	–	–
<p><b>MP_iom2_enable</b></p> <p>This procedure enables the IOM<sup>®</sup>-2 interrupts of the DSP. Sending or receiving data over the IOM<sup>®</sup>-2 interface is only possible if this procedure has been called. After reset the IOM<sup>®</sup>-2 interrupts are disabled. After the call of <code>MP_iom2_enable</code> the audio FIFOs are initialized as follows: The audio input FIFO contains 1 sample (value = 0xFFFD) and the audio output FIFO contains 148 samples (value = 0xFFFD). This procedure must therefore be called before the <code>MP_AUDIO_SYNC</code> procedure.</p>	45	–	–
<p><b>MP_offset_compensation</b></p> <p>This procedure performs offset measurement and compensation. The following function is performed:</p> <p><math>(i\_offset, q\_offset) = EM\_offset\_measurement(n\_samples)</math>  <code>MP_read_bbd_in_fifo_init(i_offset, q_offset)</code>.</p>	63	–	–
<p><b>MP_read_audio_in_fifo</b></p> <p><code>n_words</code> words from the audio data input FIFO are copied to the buffer <code>buff_id</code> in the DSP data memory. This FIFO collects the audio samples from the ADC converter located in the handset. The procedure waits until the FIFO contains sufficient data. The time-out is expressed in steps of 100 <math>\mu</math>s. If time-out occurs a <code>TIMEOUT_AUDIO_IN_FIFO</code> error message is automatically sent to the SC.</p>	46	<code>buff_id</code> <code>n_words</code> <code>timeout_val</code>	–

## GSM signal processing IC

## PCF5083

DESCRIPTION	ID	PARAMETERS	RETURN VALUES
<p><b>MP_read_bbd_in_fifo</b></p> <p>ABS(<math>n\_samples</math>) I and Q pairs are copied from the baseband digitizer (BBD) input FIFO to the buffer determined by <code>buff_id</code> located in the DSP data RAM. If <math>n\_samples</math> is greater than zero the de-rotating and offset compensation is performed while copying. Otherwise no further processing is performed. The procedure waits until the FIFO contains sufficient data. In the event of <code>time_out</code> occurring (10 ms), an ERROR message is sent to the SC.</p>	47	<code>buff_id</code> <code>n_samples</code>	–
<p><b>MP_read_bbd_in_fifo_init</b></p> <p>Initialization of <code>MP_read_bbd_in_fifo</code>. The offset values <code>i_offset</code> and <code>q_offset</code> are subtracted from the I and Q components during succeeding calls of <code>MP_read_bbd_in_fifo</code>.</p>	58	<code>i_offset</code> <code>q_offset</code>	–
<p><b>MP_read_data_frame</b></p> <p>This procedure reads an uplink data frame consisting of <code>framelength</code> (typically 160) words from the audio input FIFO. The format of the uplink data frame is described in Section 9.1.5.3. The user data block is extracted and copied to <code>SCRATCH_BUFF</code>.</p> <p>If the control data block is not empty, the procedure returns the packed control bytes to the SC. The packing method used is most significant bytes first (big endian, 68000 compatible).</p> <p>The procedure waits for <code>timeout</code> × 100 μs for the data frame. If time-out occurs <code>TIMEOUT_AUDIO_IN_FIFO</code> error message is automatically sent to the SC.</p>	76	<code>user_buff_id</code> <code>framelength</code> <code>timeout</code>	<code>n_words</code> <code>n_user_bytes</code> <code>n_ctrl_bytes</code> <code>ctrl_bytes[ ]</code>
<p><b>MP_set_side_tone</b></p> <p>The DSP automatically adds the attenuated microphone input signal to the loudspeaker output signal, whereby the 3 LSBs remain unchanged (see Section 9.1.4). The attenuation to be used is described in Table 61.</p>	31	<code>att</code>	–

## GSM signal processing IC

## PCF5083

DESCRIPTION	ID	PARAMETERS	RETURN VALUES
<p><b>MP_write_audio_out_fifo</b></p> <p>The n_words located in buffer buff_id are copied from the DSP data memory into the audio output FIFO. This FIFO collects the samples that have to be sent to the DAC.</p> <p>If the FIFO is not empty enough to receive all samples an ERROR message is sent to the SC.</p>	49	buff_id n_words	–
<p><b>MP_write_data_frame</b></p> <p>This procedure generates an output data frame of framelength words (typical 160) as described in Section 9.1.5.2 and writes it into the audio output FIFO. All n_ctrl_bytes control data bytes are unpacked and written to the control data block. If no control bytes are available, only the control data header is transmitted. The channel decoder output data located in buffer user_buff_id are written to the user data block.</p> <p>If the audio output FIFO is not empty enough for framelength samples, an ERROR message is automatically sent to the SC (AUDIO_FIFO_FULL).</p>	77	user_buff_id framelength n_ctrl_bytes ctrl_bytes[ ]	–
<p><b>MP_write_mod_out_fifo</b></p> <p>The n_words located in buffer buff_id are copied to the modulator output FIFO. This FIFO collects the samples that have to be transmitted to the GMSK modulator.</p> <p>If the FIFO is not empty enough to receive all samples an ERROR message is automatically sent to the SC.</p>	50	buff_id n_words	–
<p><b>MP_write_normal_bursts</b></p> <p>The n_bursts normal bursts located in buffer buff_id are copied to the modulator output FIFO.</p> <p>If the FIFO is not empty enough to receive all samples an ERROR message is automatically sent to the SC.</p>	50	buff_id n_burst	–

## GSM signal processing IC

## PCF5083

DESCRIPTION	ID	PARAMETERS	RETURN VALUES
<p><b>SP_decoder_TCHFS</b></p> <p>GSM full-rate speech decoder as defined in "GSM Rec. 06.01, 06.10, 06.11, 06.12, 06.31 and 06.32". The following tasks are performed:</p> <p>Speech decoding algorithm.</p> <p>Frame repetition and muting, in the event of a Bad Frame Indication (BFI) and/or bad receive quality.</p> <p>SID frame detection and Comfort Noise Insertion (CNI) in the event of discontinuous transmission (DTX).</p> <p>Integrated handsfree algorithm using a weighting balance and comfort noise insertion.</p> <p>The speech parameters in SCRATCH_BUFF are decoded. The audio output data (see Table 32) is returned in SCRATCH_BUFF.</p> <p>The three input parameters determine the operating mode of the speech decoder. The dl_dtx_flag enables DTX in down link when set. Note that the dl_dtx_flag should always be set to 1 except for test purposes.</p> <p>The operation_mode consists of 3 fields: TMODE, HF and ATT. These fields are shown in Table 62.</p> <p>The TMODE field is copied to the audio output data (bits TM0 to TM2 according to Table 36) in accordance with "GSM recommendation 11.10, section III.1.2.4.7". TMODE can take the following values:</p> <p>TMODE = 0; normal operation.</p> <p>TMODE = 1; test of speech decoder. In this test mode an automatic reset of the internal state variables is performed if a rising edge of the RESD bit contained in the audio input data (defined in Table 36) is detected.</p> <p>TMODE = 2; test of speech encoder.</p> <p>TMODE = 4; test of acoustic devices.</p> <p>The HF fields enables (HF = 1) or disables (HF = 0) the handsfree mode of the speech codec.</p> <p>The ATT field has only a meaning in handsfree mode. It informs the handsfree program about the attenuation between loudspeaker and microphone in 3 dB steps. ATT = 0 means 0 dB, ATT = 7 means 21 dB. For proper operation the ATT field has to be adjusted according to the volume control of the loudspeaker. The arrangement of loudspeaker and microphone has to be such that the attenuation at maximum volume level does not exceed 0 dB.</p> <p>The binary taf (time alignment flag) marks with taf = 1 those traffic frames that are aligned with the SACCH multiframe structure defined in "GSM Rec. 05.08".</p>	51	dtx_flag taf operation_mode	-

## GSM signal processing IC

## PCF5083

DESCRIPTION	ID	PARAMETERS	RETURN VALUES
<p><b>SP_decoder_TCHFS_init</b></p> <p>Initialization of SP_decoder_TCHFS.</p>	52	–	–
<p><b>SP_encoder_TCHFS</b></p> <p>GSM full-rate speech encoder as defined in “GSM Rec. 06.01, 06.10, 06.11, 06.12, 06.31 and 06.32”. The following tasks are performed.</p> <p>Speech encoding algorithm.</p> <p>Voice Activity Detection (VAD) algorithm in the event of discontinuous transmission (DTX).</p> <p>Integrated handsfree algorithm using a weighting balance and comfort noise insertion.</p> <p>The 160 words audio input data in SCRATCH_BUFF (see Table 36) are processed. The encoded speech parameters are returned in SCRATCH_BUFF.</p> <p>The dtx_flag enables or disables DTX as defined below:</p> <p>dtx_flag = 1 enables DTX. dtx_flag = 0 disables DTX.</p> <p>If test_mode = 2 (test of speech encoder) then the RESE bit in SCRATCH_BUFF is checked. If a rising edge is detected, the internal state variables are cleared.</p> <p>If bypass flag = 1; it disables the speech encoder. In this case the parameter bits D1 to D260 (see Table 36) are directly passed to the output.</p> <p>If bypass flag = 2; the speech encoder is only bypassed, if the control flag BM0 (see Table 36) is set to 1 and BM1 is set to 0, otherwise the speech coder is executed. This mode is required for remote interrogation of an external answering machine.</p>	53	dtx_flag test_mode bypass_flag	–
<p><b>SP_encoder_TCHFS_init</b></p> <p>Initialization of SP_encoder_TCHFS.</p>	54	–	–
<p><b>TG_tone_gen</b></p> <p>This procedure adds a tone consisting of up to 3 sine waves to the audio signal located in SCRATCH_BUFF, whereby the 3 LSB's remain unchanged (see Section 9.1.4). For more information refer to TG_tone_gen_init.</p>	59	–	–

## GSM signal processing IC

## PCF5083

DESCRIPTION	ID	PARAMETERS	RETURN VALUES
<p><b>TG_tone_gen_init</b></p> <p>This routine initialises TG_tone_gen. The parameters start_att_inc_factor and start_att_factor indicate how the sine wave starts. Frequency, decay and amplitude factor for each oscillation are set. If one of the sine values is zero the state variables of this oscillation are not set. This can be used to change parameters of the oscillation during tone generation.</p> <p>The input signal is multiplied with the factor ampl_input. The ampl_input is represented in 16-bit fixed-point arithmetic with 14 fractional bits (0X4000 corresponds to 1.0).</p> <p>The parameter start_att is the factor for starting the generated tone softly. Each sample of the generated tone signal is multiplied by start_att. The start_att is multiplied by start_att_inc every sample. Both start_att and start_att_inc are represented in 16-bit fixed-point arithmetic with 14 fractional bits (0X4000 corresponds to 1.0).</p> <p>The parameter start_att_inc is the factor for increment of the start_att_factor and is specified below:</p> <p>0X4000: start_att_factor is not changed  0X4001 to 0X7FFF: start_att_factor is incremented  0X0000 to 0X3FFF: start_att_factor is decremented.</p> <p>If start_att_inc_factor <math>\times</math> start_att_factor is not greater than start_att_factor + 0.5 there is no increment because of rounding.</p> <p>cos_omega_1, cos_omega_2, cos_omega_3 = 32768 cos(<math>\Omega</math>) is the value to determine the oscillation frequency of the Nth sinus oscillation</p> <p><math>\Omega = 2 \times D \times f/f_s</math>, where f is the frequency of the oscillation, <math>f_s</math> is the sampling frequency.</p> <p>sin_omega_1, sin_omega_2, sin_omega_3 = 32768 sin(<math>\Omega</math>) is the value to determine the amplitude of the oscillation.</p> <p>decay_N = r is the value to determine the decay of the sinus oscillation (r is the pole radius of the generating filter):</p> <p>0X4000: no decay  0X0001 to 0X3FFF: decay  0X4001 to 0X7FFF: not stable.</p> <p>ampl_sin_1, ampl_sin_2, ampl_sin_3 are the values to determine the amplitude of the sine oscillation.</p>	57	ampl_input start_att start_att_inc  cos_omega_1 sin_omega_1 decay_1 ampl_1  cos_omega_2 sin_omega_2 decay_2 ampl_2  cos_omega_3 sin_omega_3 decay_3 ampl_3	–
<p><b>TG_tone_gen_off</b></p> <p>This procedure switches off the tone generation. To restart tone generation TG_tone_gen_init has to be called again.</p>	33	–	–

**Notes**

1. The on-chip firmware does not include the basic ciphering algorithms A5/1 and A5/2, which produce BLOCK1 and BLOCK2 in accordance with "GSM recommendation 3.20". Therefore the firmware only works correctly, if encryption and decryption is switched-off. If ciphering is required, a corresponding software module must be downloaded into the on-chip program RAM. More information will be made available with application notes.

GSM signal processing IC

PCF5083

**Table 59** Registers that may be read (see Table 58)

REGISTER	
NUMBER	NAME
0	pxs0
1	pxs1
2	pys0
3	pys1
4	sas
5	eas
6	dcuc
7	acuc
8	sp
9	iopc
10	iopcx
11	sioc
12	soym
13	iopf
14	eb
15	reserved
16	mc

**Table 60** Registers that may be changed (see Table 58)

REGISTER	
NUMBER	NAME
0	pxs0
1	pxs1
2	pys0
3	pys1
4	sas
5	eas
6	dcuc
7	acuc
8	sp
9	iopc
10	iopcx
11	sioc
12	soym
13	siyc
14	soyc
15	ecb
16	mc

**Table 61** Determination of the attenuation routine (see Table 58); note 1

att	DESCRIPTION
0	no side tone
1	3 dB attenuation
2	6 dB attenuation
3	9 dB attenuation
4	12 dB attenuation
5	15 dB attenuation
6	18 dB attenuation
-1	loop back test microphone to loud speaker

**Note**

1. After reset att is initialized with zero.

**Table 62** Operation\_mode fields

15	14	13	12	11	10	9	8	7	6	5	4	3	2	1	0
don't care									ATT		HF	TMODE			

GSM signal processing IC

PCF5083

9.3.2 PERFORMANCE OF GSM BASEBAND PROCEDURES

The performance of the PCF5083 GSM baseband procedures is specified within this section.

All performances are valid for the following conditions; unless otherwise specified. However, performance figures are only preliminary or must be fixed respectively.

- AGC and quantization in accordance with Fig.16
- Receiver input noise (AWGN); -111 dBm
- IF filter with a frequency characteristic as shown in Fig.20
- Constant frequency offset (df) in baseband signal;  $-100 \text{ Hz} \leq df \leq 100 \text{ Hz}$
- Gain mismatch in I and Q path less than 0.5 dB
- Phase error less than  $2^\circ$
- Channel models in accordance with "GSM Rec. 05.05".

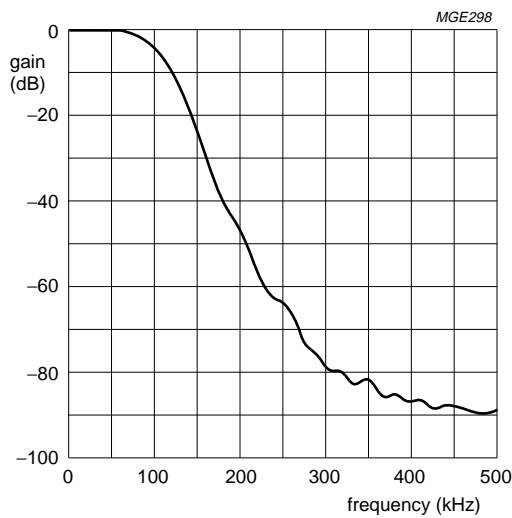

Fig.20 Frequency response of the IF filter.

9.3.2.1 Usable receiver input level range

Table 63 Usable receiver input level range

SYMBOL	PARAMETER	CONDITION	MAX.	UNIT
NER1	nominal error rate; TCH/FS class II	static; -10 dBm	$2 \times 10^{-5}$	-
NER2	nominal error rate; TCH/FS class II	static; -50 dBm	$2 \times 10^{-5}$	-
NER3	nominal error rate; TCH/FS class II	static; -85 dBm	$2 \times 10^{-5}$	-
NER4	nominal error rate; TCH/FS class II	EQ50; -40 dBm	2.5	%
NER5	nominal error rate; TCH/FS class II	EQ50; -85 dBm	2.5	%



## GSM signal processing IC

## PCF5083

## 9.3.2.2 Sensitivity

**Table 64** Equalizer and channel decoder sensitivity; note 1

SYMBOL	PARAMETER	CONDITION	MAX.	UNIT
FER1	frame erasure rate	static; ideal FH	$5 \times 10^{-4}$	–
RBER6	residual bit error rate; TCH/FS class Ib	static; ideal FH	0.2	%
RBER7	residual bit error rate; TCH/FS class II	static; ideal FH	0.5	%
FER2	frame erasure rate	TU50; no FH	4.0	%
RBER3	residual bit error rate; TCH/FS class Ib	TU50; no FH	0.2	%
RBER4	residual bit error rate; TCH/FS class II	TU50; no FH	5.0	%
RBER5	residual bit error rate; TCH/FS class II	RA250; no FH	6.0	%
RBER6	residual bit error rate; TCH/FS class II	HT100; no FH	7.0	%
FER3	frame erasure rate; FACCH	TU50; no FH	6.0	%
FER4	frame erasure rate; SCH	TU50; no FH	13.0	%

**Note**

1. Input level: –102 dBm.

## 9.3.2.3 Co-channel rejection

**Table 65** Equalizer and channel decoder co-channel rejection; note 1

SYMBOL	PARAMETER	CONDITION	MAX.	UNIT
FER5	frame erasure rate, TCH/FS	TU3; no FH	15.0 (2.0)	%
RBER7	residual bit error rate; TCF/FS class Ib	TU3; no FH	1.0 (0.1)	%
RBER8	residual bit error rate; TCF/FS class II	TU3; no FH	3.0 (6.0)	%
FER6	frame erasure rate; FACCH	TU3; no FH	18.0	%
FER7	frame erasure rate; SCH	TU50; no FH	14.0	%

**Note**

1. Signal levels:
  - a) Level of wanted signal –85 dBm.
  - b) Level of unwanted signal –94 dBm.

## 9.3.2.4 Erroneous frame indication performance

**Table 66** Equalizer and channel decoder erroneous frame indication performance

SYMBOL	PARAMETER	CONDITION	MAX.	UNIT
FDR1	false detection rate of FACCH, SACCH or SDCCH	random RF input; level = –95 dBm	tbf	–
FDR2	false detection rate of TCH/FS	random RF input; level = –95 dBm	0.1	%

GSM signal processing IC

PCF5083

9.4 Software applications

This section contains examples for several basic GSM channels. For every example the procedures to be executed within the DSP are shown in the form of tables. The first column contains the TDMA frame number *fn* in which the EXEC\_PROC messages should be sent to the DSP. The 2nd column shows the corresponding procedures with all parameters. Parameters in uppercase are constants, lowercase parameters are variables. The 3rd column contains the number words  $N_w$  to be transmitted to the DSP within frame *fn* (PACKET message assumed). The columns RX and MX contain the number of I and Q pairs to be sampled in the receive and monitoring timeslots of TDMA frame *fn*. Column TX contains the number of bits to sent to the GMSK modulator within the transmit timeslot. The tables are based upon the general rule that an EXEC\_PROC message for a procedure that starts execution in TDMA frame *n* has to be sent in TDMA frame *N - 1*.

Unless otherwise noted, the corresponding PROC\_RETURN message will be available at the latest at the end of TDMA frame *N+1*, i.e. if the messages are read by the SC at beginning of every TDMA frame, the PROC\_RETURN message will be available in frame *N + 2*. Start and end of a TDMA frame are defined by the falling edge of the  $\overline{\text{FRAME\_INT}}$  signal produced by the timer core.

9.4.1 RECEIVING A CCH BLOCK

Table 67 shows how to receive a CCH block and to perform monitoring of two neighbouring cells in parallel. It is assumed that the CCH block has to be received in the frames *N* to *N + 3*. Note that the TX timeslot is used for monitoring in this example.

Table 67 Procedures to be started for receiving a CCH block

fn	PROCEDURES <sup>(1)</sup>	$N_w$	RX	TX	MX
N - 1	CP_rx_normal_burst (CCH_CMI_BUFF1, tsc, agc_gain1); CP_power_measure (agc_gain2) CP_power_measure (agc_gain3)	15	-	-	-
N	CP_rx_normal_burst (CCH_CMI_BUFF2, tsc, agc_gain1); CP_power_measure (agc_gain2) CP_power_measure (agc_gain3)	15	149	80	80
N + 1	CP_rx_normal_burst (CCH_CMI_BUFF3, tsc, agc_gain1); CP_power_measure (agc_gain2) CP_power_measure (agc_gain3)	15	149	80	80
N + 2	CP_rx_normal_burst (CCH_CMI_BUFF4, tsc, agc_gain1); CM_decoder_CCH( ); CP_power_measure (agc_gain2) CP_power_measure (agc_gain3)	18	149	80	80
N + 3	-	-	149	80	80

Note

- 1. Procedures to be started via EXEC\_PROC in TDMA frame FN.

## GSM signal processing IC

## PCF5083

## 9.4.2 TRANSMITTING A CCH BLOCK

This example shows how to transmit a CCH block. The transmission is performed in the TDMA frames N to N + 3. Only one message has to be sent in order to transmit a CCH block.

**Table 68** Procedures to be started for transmitting a CCH block

fn	PROCEDURES <sup>(1)</sup>	N <sub>w</sub>	RX	TX	MX
N – 1	CP_tx_CCH (tsc, cch_msg)	15	–	–	–
N	–	–	–	156	–
N + 1	–	–	–	156	–
N + 2	–	–	–	156	–
N + 3	–	–	–	156	–

**Note**

1. Procedures to be started via EXEC\_PROC in TDMA frame FN.

## 9.4.3 FB SEARCH FOR TIMING SYNCHRONIZATION

This example shows how to achieve time synchronization when the mobile is in IDLE mode or is on a channel with a 51 multiframe structure.

**Table 69** Procedures to be started for FB search for timing synchronization

fn	PROCEDURES <sup>(1)</sup>	N <sub>w</sub>	RX	TX	MX
N	FB_search_fcb_init(15) FB_search_fcb( )	9	–	–	–
N+11, N+22	FB_search_fcb( )	5	–	–	–
N+1, N+12, N+23		–	–	–	1404
N+2, N+13, N+24	FB_search_fcb( )	5	–	–	
N+3, N+14, N+25		–	–	–	1404
N+4, N+15, N+26	FB_search_fcb( )	5	–	–	
N+5, N+16, N+27		–	–	–	1404
N+6, N+17, N+28	FB_search_fcb( )	5	–	–	
N+7, N+18, N+29		–	–	–	1404
N+8, N+19, N+30	FB_search_fcb( )	5	–	–	
N+9, N+20, N+31		–	–	–	1404
N+10, N+21, N+32		–	–	–	

**Note**

1. Procedures to be started via EXEC\_PROC in TDMA frame FN.

## GSM signal processing IC

## PCF5083

## 9.4.4 PROCESSING A TCH/FS MULTIFRAME

## 9.4.4.1 Normal mode

Figure 21 depicts the timing diagram of the procedure execution timing for a TCH/FS multiframe. Table 70 shows the procedures to be executed within the DSP for processing of a TCH/FS multiframe in normal mode. It is assumed that an even numbered time slot is assigned.

**Table 70** Procedures to be executed for processing a TCH/FS multiframe in normal mode

FN MOD 26	PROCEDURES	N <sub>w</sub>	RX	TX	MX
0	CP_rx_normal_burst (TCH_CMI_BUFF2, tsc, agc_gain) CP_power_measure (agc_gain1) MP_audio_sync(2, 2)	17	149	156	80
4, 13, 17	CP_rx_normal_burst (TCH_CMI_BUFF2, tsc, agc_gain) CP_power_measure (agc_gain1)	12	149	156	80
8	{CM_encoder_CCH (cch_msg[12])}; note 1 CP_rx_normal_burst (TCH_CMI_BUFF2, tsc, agc_gain) CP_rx_normal_burst (CCH_INFO_BUFFi, tsc) CP_power_measure (agc_gain1)	32	149	156	80
21	CP_rx_normal_burst (TCH_CMI_BUFF2, tsc, agc_gain) CI_encrypt (SCRATCH_BUFF1); note 2 CP_power_measure (agc_gain1)	17	149	156	80
1, 5, 9, 14, 18, 22	CP_rx_normal_burst (TCH_CMI_BUFF3, tsc, agc_gain) CP_tx_speech (dtx, bpf, tm, taf, tsc, ff, fm[12]) CP_power_measure (agc_gain1)	33	149	156	80
2, 6, 10, 15, 19	CP_rx_normal_burst (TCH_CMI_BUFF4, tsc, agc_gain) CP_rx_speech (dtx_flag, taf, test_mode) CP_power_measure (agc_gain1)	18	149	156	80
3, 7, 12, 16, 20	CP_rx_normal_burst (TCH_CMI_BUFF1, tsc, agc_gain) CP_power_measure (agc_gain1)	12	149	156	80
11	CP_rx_normal_burst (CCH_CMI_BUFF1, tsc, agc_gain) [CM_decoder_CCH( )]; note 3 CP_power_measure (agc_gain1)	14	149	156	80

## GSM signal processing IC

## PCF5083

FN MOD 26	PROCEDURES	N <sub>w</sub>	RX	TX	MX
23 start of FB monitoring	CP_rx_normal_burst (TCH_CMI_BUFF4, tsc, agc_gain) FB_search_FCB_INT (n_int, threshold) FB_search_FCB( ) CP_rx_speech (dtx_flag, taf, test_mode)	22	149	156	80
23 continue FB monitoring	CP_rx_normal_burst (TCH_CMI_BUFF4, tsc, agc_gain) FB_search_FCB( ) CP_rx_speech (dtx_flag, taf, test_mode)	17	149	156	80
23 decode SCh	CP_rx_normal_burst (TCH_CMI_BUFF4, tsc, agc_gain) CP_rx_speech (dtx_flag, taf, test_mode) CP_rx_SCH( )	17	149	156	80
23 level measurement	CP_rx_normal_burst (TCH_CMI_BUFF4, tsc, agc_gain) CP_rxlev3 (agc_gain1, agc_gain2, agc_gain3); note 4 CP_rx_speech (dtx_flag, taf, test_mode)	20	149	156	80
24	CI_decrypt (SCRATCH_BUFF,1); note 5	0	149	156	1404 <sup>(6)</sup> or 167 <sup>(7)</sup>
25	CP_rx_normal_burst (TCH_CMI_BUFF1, tsc, agc_gain) CP_power_measure (agc_gain1)	17	80 or 0	80 or 0	80 or 0

**Notes**

1. CM\_encoder\_CCH is only called, if the current multiframe contains the 1st SACCH sub-block.
2. Dummy encryption to increment TDMA frame counters (skip Idle frame).
3. CM\_decoder\_CCH is only called, if the current multiframe contains the 4th SACCH sub-block.
4. If the BCCh identification of the neighbouring cells is not required in a certain idle frame, then up to 3 level measurements can be performed in that frame.
5. Dummy encryption to increment TDMA frame counter (skip idle frame).
6. Monitoring of a frequency correction burst from a neighbouring cell.
7. Decoding of a synchronization burst from a neighbouring cell.

GSM signal processing IC

PCF5083

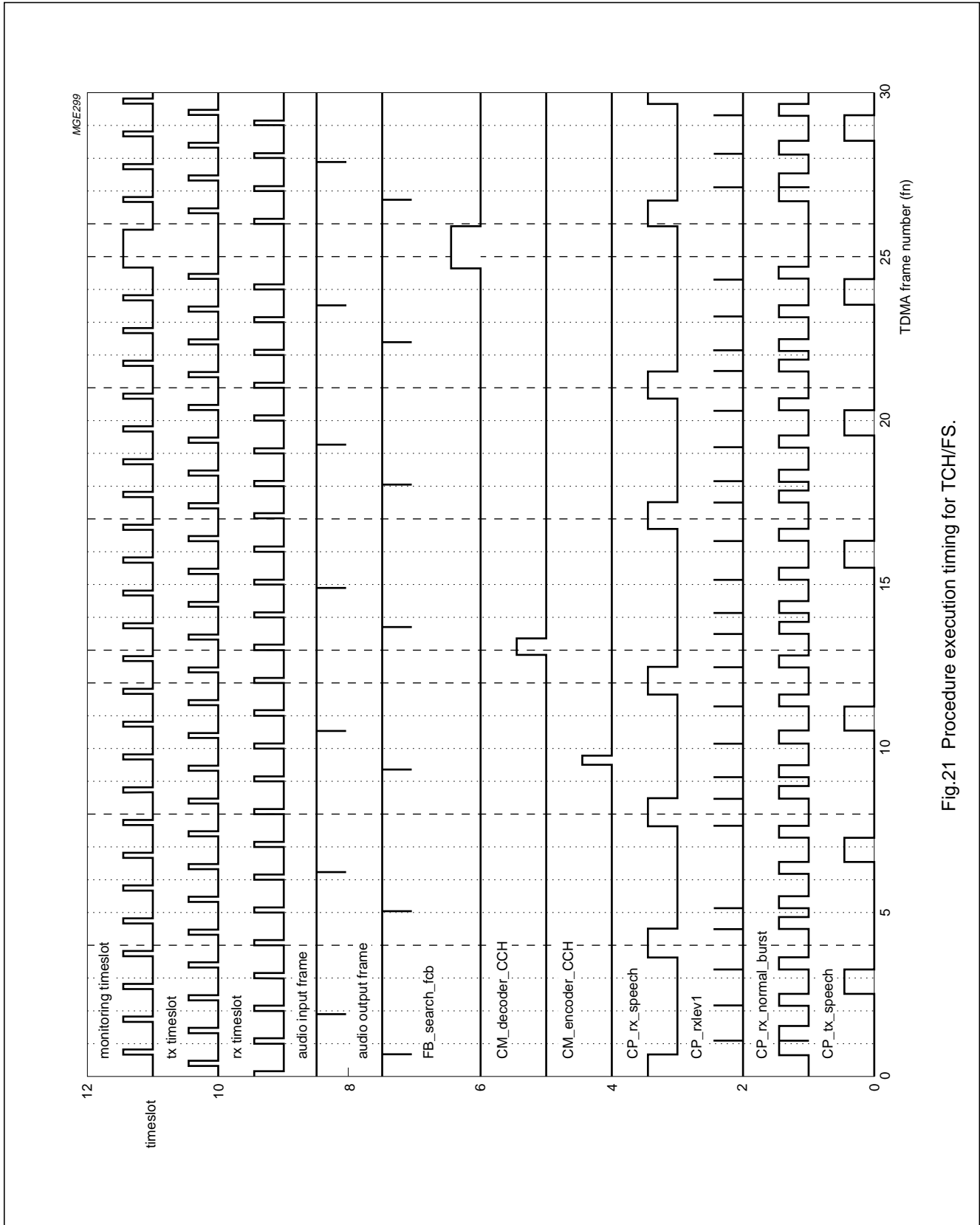

Fig.21 Procedure execution timing for TCH/FS.

## GSM signal processing IC

## PCF5083

## 9.4.4.2 Loop-back mode

During TCH\_LOOP mode the CP\_TX\_SPEECH and CP\_RX\_SPEECH procedures have to be replaced by the following procedures:

- Replacement for CP\_tx\_speech:
  - MP\_read\_audio\_in\_fifo (SCRATCH\_BUFF, 160)
  - DB\_copy\_buffer (TCH\_LOOP\_BUFF, SCRATCH\_BUFF, 0, 0, 82)
  - CM\_convert\_tchfs\_data(bfi\_sig\_flag)
  - CM\_encoder\_tchfs(dtx\_flag, taf, facch\_flag, facch\_msg[12])
  - CP\_tx\_four\_normal\_bursts (tsc)
- Replacement for CP\_rx\_speech:
  - CM\_decoder\_tchfs( )
  - DB\_copy\_buffer(SCRATCH\_BUFF, TCH\_LOOP\_BUFF, 0, 0, 82)
  - DB\_fill\_buffer(SCRATCH\_BUFF, 0, 0, 160)
  - MP\_write\_audio\_out\_fifo(SCRATCH\_BUFF, 160).

## 9.4.4.3 Initialization messages for normal mode

Before the first TDMA frame of a TCH/FS can be processed, several initialization messages have to be sent to the DSP. Initialization is done in 2 DMA frames as shown in Table 72.

The first one or two results of CM\_decoder\_TCH are based on only partially observed input data, since 8 successive normal bursts are needed due to interleaving.

Table 71 Parameter nb

nb	t <sub>2s</sub>						
	0	4	8	13	17	21	25
4	0	4	8	13	17	21	25
3	1	5	9	14	18	22	10
2	2	6	–	15	19	23	–
5	3	7	12	16	20	24	–
6	11	–	–	–	–	–	–

Table 72 Initialization messages

TDMA FRAME	EXPLANATION
FN <sub>s</sub> – 2	In this TDMA frame the message for initialization of speech CODEC, channel CODEC and ciphering are sent to the DSP. Furthermore the modulator out FIFO is filled with the proper number of bursts and synchronization between TDMA frame timing and speech frame timing is performed and the audio interface is enabled by setting the IO1 pin. No data is received or transmitted within this frame.
FN <sub>s</sub> – 1	In this TDMA frame the EXEC_PROC messages for the procedures processing the data of frame FN <sub>s</sub> are sent to the DSP. No data is received or transmitted within this frame.
FN <sub>s</sub>	In this TDMA frame the normal processing of receive and transmit data takes place.

Table 73 Initialization procedures

fn	PROCEDURES <sup>(1)</sup>	N <sub>W</sub>	RX	TX	MX
FN <sub>s</sub> – 2	CP_start_TCHFS (enc_flag, dec_flag, t <sub>1s</sub> , t <sub>2s</sub> , t <sub>3s</sub> , kc[4], nb); notes 2 and 3 DB_write_register (11, 0x0100, 1); set IO1 = 1	21	0	0	0
FN <sub>s</sub> – 1	The correct value for N <sub>W</sub> must be looked-up in Table 70	'...'	0	0	0
FN <sub>s</sub>	The correct value for N <sub>W</sub> must be looked up in Table 70	'...'	149	164	151

## Notes

1. Procedures to be started via EXEC\_PROC in TDMA frame FN (TCH/FS normal mode).
2. t<sub>1s</sub> = FN<sub>s</sub> divided by 26 × 51;  
t<sub>2s</sub> = FN<sub>s</sub> modulo 26;  
t<sub>3s</sub> = FN<sub>s</sub> modulo 51.
3. The parameter nb determines the number of normal bursts to be written into the modulator output FIFO in the initialization frame. It depends on the frame number of the 1st processed frame in accordance with Table 71.

## GSM signal processing IC

## PCF5083

## 9.4.4.4 Handover mode

Table 74 shows the procedures to be executed within the DSP for processing of a TCH/FS multiframe in Handover mode.

**Table 74** Procedures to be executed for processing a TCH/FS multiframe in handover mode

FN MOD 26	PROCEDURES	N <sub>w</sub>	RX	TX	MX
0, 4, 13, 17	CP_tx_RACH (bsic, rach_msg) CP_rx_normal_burst (TCH_CMI_BUFF2, tsc, agc_gain) CP_power_measure (agc_gain1)	12	149	156	80
8, 21	CP_tx_RACH (bsic, rach_msg) CP_rx_normal_burst (TCH_CMI_BUFF2, tsc, agc_gain) CI_encrypt (SCRATCH_BUFF,1); note 1 CP_power_measure (agc_gain1)	12	149	156	80
1, 5, 9, 14, 18, 22	CP_tx_RACH (bsic, rach_msg) CP_rx_normal_burst (TCH_CMI_BUFF3, tsc, agc_gain) CI_encrypt (SCRATCH_BUFF, 4) MP_read_audio_in_fifo (SCRATCH_BUFF, 160) CP_power_measure (agc_gain1)	33	149	156	80
2, 6, 10, 15, 19, 23	CP_tx_RACH (bsic, rach_msg) CP_rx_normal_burst (TCH_CMI_BUFF4, tsc, agc_gain) DB_fill_buffer (SCRATCH_BUFF,0,0,160) MP_write_audio_out_fifo (SCRATCH_BUFF, 160) CM_decoder_TCH (dtx_flag, taf, test_mode) CP_power_measure (agc_gain1)	18	149	156	80
3, 7, 12, 16, 20	CP_tx_RACH (bsic, rach_msg) CP_rx_normal_burst (TCH_CMI_BUFF1, tsc, agc_gain) CP_power_measure (agc_gain1)	12	149	156	80
11	CP_tx_RACH (bsic, rach_msg) CP_rx_normal_burst (CCH_CMI_BUFFi, tsc, agc_gain) [CM_decoder_CCH( )]; note 2 CP_power_measure (agc_gain1)	14	149	156	80
24	CP_tx_RACH (bsic, rach_msg) CI_decrypt (SCRATCH_BUFF,1); note 3	15	149	156	80
25	CP_tx_RACH (bsic, rach_msg) CP_rx_normal_burst (TCH_CMI_BUFF1, tsc, agc_gain) CP_power_measure (agc_gain1)	12	–	156	–

## Notes

1. Dummy encryption to increment TDMA frame counters (skip Idle + SACCH frame).
2. CM\_DECODER\_CCH is only called, if the current multiframe contains the 4th SACCH sub-block.
3. Dummy encryption to increment TDMA frame counters (skip Idle frame).



## GSM signal processing IC

## PCF5083

## 9.4.4.5 Initialization messages for Handover mode

Table 75 shows how a handover from TCH/FS to another TCH/FS has to be processed. 'fn<sub>H</sub>' is the first frame transmitted on the new TCH/FS in Handover mode (handover access burst transmitted in uplink). 'fn<sub>S</sub>' is the first frame processed in normal mode on the new TCH/FS (normal burst in up link).

**Table 75** Initialization procedures for handover mode

fn	PROCEDURES <sup>(1)</sup>	N <sub>W</sub>	RX	TX	MX
.	procedure calls for TCH/FS in normal mode; the correct value for N <sub>W</sub> must be looked-up in Table 70.	'...'	149	156	80
.	.	.	.	.	.
.	procedure calls for TCH/FS in normal mode; the correct value for N <sub>W</sub> must be looked-up in Table 70.	'...'	149	156	80
.	–	0	149	156	80
fn <sub>H</sub> – 2	CP_start_TCHFS (enc_flag, dec_flag, t1 <sub>s</sub> , t2 <sub>s</sub> , t3 <sub>s</sub> , kc[4], nb); notes 2 and 3 MP_exec_reset (MOD_OUT_FIFO); DB_write_register(11, 0x0100, 1); set IO1 = 1	21	0	0	0
fn <sub>H</sub> – 1	procedure calls for TCH/FS in handover mode; the correct value for N <sub>W</sub> must be looked-up in Table 70.	'...'	0	0	0
fn <sub>H</sub>	procedure calls for TCH/FS in handover mode; the correct value for N <sub>W</sub> must be looked-up in Table 70.	'...'	149	156	80
.	procedure calls for TCH/FS in handover mode; the correct value for N <sub>W</sub> must be looked-up in Table 70.	'...'	149	156	80
fn <sub>S</sub> – 2	procedure calls for TCH/FS in handover mode BB_normal_burst (SCRATCH_BUFF, SCRATCH_BUFF, tsc, nb) MP_write_normal_bursts (SCRATCH_BUFF, nb); note 3	29	149	156	80
fn <sub>S</sub> – 1	procedure calls for TCH/FS in normal mode; the correct value for N <sub>W</sub> must be looked-up in Table 70.	'...'	149	156	80
fn <sub>S</sub>	procedure calls for TCH/FS in normal mode; the correct value for N <sub>W</sub> must be looked-up in Table 70.	'...'	149	156	80

**Notes**

- Procedures to be started via EXEC\_PROC in TDMA frame FN (TCH/FS normal mode).
- t1<sub>s</sub> = FN<sub>S</sub> divided by 26 × 51;  
t2<sub>s</sub> = FN<sub>S</sub> modulo 26;  
t3<sub>s</sub> = FN<sub>S</sub> modulo 51.
- The parameter nb determines the number of normal bursts to be written into the modulator output FIFO in the initialization frame. It depends on the frame number of the 1st processed frame in accordance with Table 71.

---

## GSM signal processing IC

PCF5083

---

### 9.5 Instruction Set

Details concerning the PCF5083 Instruction Set can be found in the *“PCF5082 Information manual”*. Some exceptions that apply to the PCF5083 are listed below:

- Moves from RAM using pointers to I/O control registers (iopc, iopcx and sioc) are not recommended due to reliability problems. Load immediate from program memory to these registers should be performed. Otherwise, access to the I/O control registers could be performed via secondary registers e.g.

bm = \*px0++ followed by sioc = bm

- All code segments using pp pointer as source must be within a disable/enable pair if interrupts are enabled e.g. disable;

.....

bm = \*pp++;

.....

- The instruction \*px0++ is illegal. Instead, use the following sequence with consideration to the point above:

dr = \*pp++;

\*px0++ = dr;

- The instruction ‘... = \*pp++’ may be located in any PROM bank (including the mirrored PROM07 at location XF800H to XFFFF0. However, the instruction will not work if located in any of the RAM banks mapped to program address space.

## GSM signal processing IC

## PCF5083

**10 MICROCONTROLLER INTERFACE**

The PCF5083 includes a standard 68000 compatible microcontroller interface. The interface consists of the lines specified in Table 76.

The 128-byte wide register space of the Timer core is selected if  $\overline{\text{HCEN\_T}}$  is asserted. The 4 byte wide register space of the DSP core is selected if  $\overline{\text{HCEN\_D}}$  is asserted. The DSP core only uses the address lines HA0 and HA1. All other address lines are don't care for the DSP core.

The Timer core accessed via  $\overline{\text{HCEN\_T}}$  does not assert  $\overline{\text{DTACK}}$ .

Registers wider than 8-bit are aligned on word boundaries with the MSB on the lowest address and the LSB on the highest address. For registers which use only three byte addresses, a reserved address location is provided to make these registers accessible as longwords.

Reserved address locations, write only bits or registers and unused bits within registers are read as zeros and don't care for write operations.

For the DSP Core refer to Section 9.1.6.

**Table 76** The Interface signal lines

SIGNAL	DESCRIPTION
HD0 to HD7	8-bit bidirectional data bus.
HA0 to HA6	7-bit unidirectional address bus.
HR/W	Read/write select line. A logic 0, writes to the PCF5083. A logic 1, reads from the PCF5083.
$\overline{\text{HCEN\_T}}$	Chip select line for the Timer core (active LOW).
$\overline{\text{HCEN\_D}}$	Chip select line for the DSP core (active LOW).
$\overline{\text{DTACK}}$	DSP core data acknowledge line (connected to the DTACK input of a 68000 compatible microcontroller).

**10.1 Register Set for the Timer Core**

**Table 77** Register set

OFFSET	REGISTER	SIZE	R/W <sup>(1)</sup>	DESCRIPTION
00, 01	MODE0_REG	14	R/W	Mode Control Register 0; see Table 78
02, 03	MODE1_REG	14	R/W	Mode Control Register 1; see Table 78
04	RXBURST0_REG	8	W	RXON length in bit
05	RXBURST1_REG	8	W	RXON length in bit
06	RXBURST2_REG	8	W	RXON length in bit
07	TXBURST0_REG	8	W	TXON length in bit
08	TXBURST1_REG	8	W	TXON length in bit
09	TXBURST2_REG	7	W	Start of the Rx burst in QB
0A, 0B	TXSTART_REG	11	W	Start of the TX burst in QB
0C, 0D	MONSTART_REG	13	W	Start of the MON burst in QB
0E, 0F	TXKEY0_REG	10	W	TXKEY0 length in QB
10, 11	TXKEY1_REG	10	W	TXKEY1 length in QB
12	GPON1_REG	6	W	Time of GPON1 getting active in TDMA frames before the end of the Sleep mode

## GSM signal processing IC

## PCF5083

OFFSET	REGISTER	SIZE	R/W <sup>(1)</sup>	DESCRIPTION
13	GPON2_REG	6	W	Time of GPON2 getting active in TDMA frames before the end of the Sleep mode
14	reserved	–	–	–
15	DSPON_REG	6	W	Time of DSPON getting active in TDMA frames before the end of the Sleep mode
16	REFON_REG	6	W	Time of (N)REFON getting active in TDMA frames before the end of the Sleep mode
17	PDRX1_REG	5	W	Time of PDRX1 getting active in 32 QB before RXON active
18	PDRX2_REG	5	W	Time of PDRX2 getting active in 32 QB before RXON active
19	PDTX1_REG		W	Time of PDTX1 getting active in 32 QB before TXON active
1A	PDTX2_REG		W	Time of NPDTX2 getting active in 32 QB before TXON active
1B	PDBIAS_REG		W	Time of PDBIAS getting active in 32 QB before TXON active
1C	PDSYN_REG		W	Time of PDSYN getting active in 32 QB before RXON/TXON active
1D	AGCSTART_REG		W	Time of DACON_REG to be sent in 32 QB before RXON active
1E	PDDELAY_REG	6	W	PDTX1, NPDTX2 and PDSYN inactive to TXKEY1 inactive delay in QB
1F	KEYOFF_REG	6	W	TXKEY2 inactive to TXKEY1 inactive delay in QB
20, 21	KEYON2_REG	9	W	TXKEY2 active to TXON active delay in QB
22, 23	KEYON1_REG	9	W	TXKEY1 active to TXON active delay in QB
24, 25	POL_REG	14	R/W	Polarity of Power-Down Control Lines; see Table 79
26, 27	MASK_REG	15	R/W	Bit mask register for Power-Down Control Lines; see Table 80
28	QBCCTRL_REG	8	R/W	Quarterbit counter control register; see Table 81
29	SQBCINC_REG	8	R	Sleep quarterbit counter increment
	STOP_REG	8	W	Stop OFF-Timer with data value A5H
2A, 2B	QBC_REG	15 13	R W	QBC access for synchronization R: read 15-bit quarterbit counter ( $\frac{1}{4}$ QB resolution) W: write 13-bit synchronization value (1 QB resolution)
2C, 2D	SLEEPCNT_REG	9	W	Number of TDMA frames to sleep
	FRAMECNT_REG	9	R	Duration of last Sleep mode period in TDMA frames
2E, 2F	HWCTRL_REG	11	R/W	Hardware Control Register; see Table 82
30 to 3F	–	–	R/W	Real Time Clock registers; see Table 83
3E	reserved	–	–	–
3F to 41	RX_REG	17	W	RF Bus: RX frequency
42	reserved	–	–	–
43 to 45	TX_REG	17	W	RF Bus: TX frequency
46	reserved	–	–	–
47. to 49	MON_REG	17	W	RF Bus: MON frequency
4A	reserved	–	–	–
4B to 4D	RXGAIN_REG	18	W	RF Bus: RX gain
4E	reserved	–	–	–
4F to 51	TXGAIN_REG	18	W	RF Bus: Gain setting for a MON burst during the TX timeslot

## GSM signal processing IC

## PCF5083

OFFSET	REGISTER	SIZE	R/W <sup>(1)</sup>	DESCRIPTION
52	reserved	–	–	–
53 to 55	MONGAIN_REG	18	W	RF Bus: MON gain
56, 57	DAC0_REG	16	W	Gain DAC value 0
58, 59	DAC1_REG	16	W	Gain DAC value 1
5A, 5B	DACON_REG	16	W	Gain DAC power-up value
5C, 5D	DACOFF_REG	16	W	Gain DAC power-down value
5E	reserved	–	–	–
5E to 61	IMCIN_REG	21	R	IMC data in
	IMCOUT_REG	28	W	IMC data out
62	MSB_REG	4	R/W	Gain Control Channel MSB Register 0: DAC0_REG bit 16 1: DAC1_REG bit 16 2: DACON_REG bit 16 3: DACOFF_REG bit 16
63	RFCTRL0_REG	8	W	RF bus control register 0
64	RFCTRL1_REG	8	W	RF bus control register 1
65	RFCTRL2_REG	8	W	RF bus control register 2
66	RFCTRL3_REG	8	W	RF bus control register 3
67	COMBINT_REG	6	R/W	Combined interrupt register; see Table 84
68	HIPRINT_REG	8	R/W	High priority interrupt register; see Table 85
69	HIPRMASK_REG	8	R/W	High priority interrupt mask register; see Table 86
6A	SIINT_REG	6	R	Serial interface interrupt register; see Table 87
6B	SIMASK_REG	5	R/W	Serial interface interrupt mask register; see Table 88
6C, 6D	IOMCON_REG <sup>(2)</sup>	16	R/W	IOM <sup>®</sup> -2 interface configuration register; see Table 89
6E, 6F	ACON_REG	13	R/W	Audio Interface configuration register; see Table 90
70	RXD_REG	8	R	RS232 data input register
	TXD_REG	8	W	RS232 data output register
71	MON0_REG	8	R/W	IOM <sup>®</sup> -2 interface monitor 0 data register
72	MON1_REG	6	R/W	IOM <sup>®</sup> -2 interface monitor 1 data register
73	CI0_REG	6	R/W	IOM <sup>®</sup> -2 interface C/I 0 data register
74	CI1_REG	6	R/W	IOM <sup>®</sup> -2 interface C/I 1 data register
75	IOMFLAG_REG	8	R	IOM <sup>®</sup> -2 interface interrupt flag register; see Table 91
76	IOMCTRL_REG	8	R/W	IOM <sup>®</sup> -2 interface control register; see Table 92
77	IOMEN_REG	8	R/W	IOM <sup>®</sup> -2 interface interrupt enable register; see Table 93
78	PORTDATA_REG	6	R/W	Parallel port data register; see Table 94
79	PORTDDIR_REG	6	R/W	Parallel port data direction register; see Table 95
7A	SYSCON_REG	7	R/W	System configuration register; see Table 96

**Notes**

1. R = read only; W = write only; R/W = read and write.
2. The flags of register IOMCON\_REG should not be changed as long as the interface is enabled with CLOCK\_MODE = 0 to prevent an unpredictable behaviour of the interface.

## GSM signal processing IC

## PCF5083

**Table 78** Mode Control Registers 0 and 1

BIT	R/W	SYMBOL	OPERATION (if bit is set)	$\overline{\text{RST}} = 0$	$\overline{\text{RSTx}} = 0^{(1)}$
0	R/W	RECRX	Generate the Rx burst timing	0	–
1	R/W	RECTX	Generate the MON burst timing during the TX timeslot	0	–
2	R/W	RECMON	Generate the MON burst timing	0	–
3	R/W	RECON	Generate the idle frame timing	0	–
4	R/W	SEND	Generate the TX burst timing	0	–
5	R/W	DTX	Enable DTX mode	0	–
6	R/W	RXLENGTH0	Select RXLENGTHx_REG for the Rx burst	0	–
7	R/W	RXLENGTH1		0	–
8	R/W	MONLENGTH0	Select RXLENGTHx_REG for the MON burst	0	–
9	R/W	MONLENGTH1		0	–
10	R/W	TXLENGTH	Select TXLENGTHx_REG for the TX burst	0	–
11	R/W	RXCAL	Generate the RX calibration timing	0	–
12	R/W	DISFRAMEINT	Disable the frame interrupt	0	–
13	R/W	USEMODE	Select MODEx_REG for the next frame	0	–

**Note**

1.  $\overline{\text{RSTx}} = 0$  means reset condition if either  $\overline{\text{RSTO}}$  or  $\overline{\text{RSTC}}$  is asserted; '–' denotes not affected from reset line. During reset ( $\overline{\text{RST}}$ ,  $\overline{\text{RSTO}}$ ,  $\overline{\text{RSTC}}$ ) only those registers with an explicitly given reset value are affected. All other registers are undefined and have to be set by the controller.

**Table 79** Polarity Register (Power-Down Control Lines)

BIT	R/W	SYMBOL	OPERATION (if bit is set)	$\overline{\text{RST}} = 0$	$\overline{\text{RSTx}} = 0^{(1)}$
0	R/W	PDRX1	Enable line has default polarity if its corresponding bit is a logic 0. Enable line has inverse default polarity if its corresponding bit is a logic 1.	0	–
1	R/W	PDRX2		0	–
2	R/W	NPDTX2		0	–
3	R/W	PDSYN		0	–
4	R/W	TXKEY1		0	–
5	R/W	TXKEY2		0	–
6	R/W	RXON		0	–
7	R/W	TXON		0	–
8	R/W	BEN		0	–
9	R/W	GPON1		0	–
10	R/W	GPON2		0	–
11	R/W	REFON		0	–
12	R/W	DSPON		0	–
13	R/W	NREFON	0	–	

**Note**

1.  $\overline{\text{RSTx}} = 0$  means reset condition if either  $\overline{\text{RSTO}}$  or  $\overline{\text{RSTC}}$  is asserted; '–' denotes not affected from reset line. During reset ( $\overline{\text{RST}}$ ,  $\overline{\text{RSTO}}$ ,  $\overline{\text{RSTC}}$ ) only those registers with an explicitly given reset value are affected. All other registers are undefined and have to be set by the controller.

## GSM signal processing IC

## PCF5083

**Table 80** Bit mask register (Power-Down Control Lines)

BIT	R/W	SYMBOL	OPERATION (if bit is set)	$\overline{\text{RST}} = 0$	$\overline{\text{RSTx}} = 0^{(1)}$
0	R/W	PDRX1	A logic 1 enables the control line. A logic 0 disables the control line, output level determined with corresponding output polarity flag	1	–
1	R/W	PDRX2		1	–
2	R/W	(N)PDTX1, (N)PDBIAS		1	–
2	R/W	NPDTX2		1	–
3	R/W	PDSYN		1	–
4	R/W	TXKEY1		1	–
5	R/W	TXKEY2		1	–
6	R/W	RXON		1	–
7	R/W	TXON		1	–
8	R/W	BEN		1	–
9	R/W	GPON1		1	–
10	R/W	GPON2		1	–
11	R/W	REFON		1	–
12	R/W	DSPON		1	–
13	R/W	NREFON	1	–	

**Note**

- $\overline{\text{RSTx}} = 0$  means reset condition if either  $\overline{\text{RSTO}}$  or  $\overline{\text{RSTC}}$  is asserted; '–' denotes not affected from reset line. During reset ( $\overline{\text{RST}}$ ,  $\overline{\text{RSTO}}$ ,  $\overline{\text{RSTC}}$ ) only those registers with an explicitly given reset value are affected. All other registers are undefined and have to be set by the controller.

**Table 81** Quarterbit Counter Control Register

Bit	R/W	SYMBOL	OPERATION (if bit is set)	$\overline{\text{RST}} = 0$	$\overline{\text{RSTx}} = 0^{(1)}$
0	R/W	SYNC	Enable SYNC mode	0	–
1	R/W	INSERT	Enable INSERT mode	0	–
2	R/W	EXTRACT	Enable EXTRACT mode	0	–
3	R/W	SLEEP	Enable Sleep mode	0	–
4	R/W	SLEEPRED	Enable Reduced Sleep mode	0	–
5	R/W	CAL	Start Sleep mode calibration procedure	0	–
6	R/W	FSC EXT	Enable IOM <sup>®</sup> -2 FSC period extension mode	0	–
7	R/W	FSC RED	Enable IOM <sup>®</sup> -2 FSC period reduction mode	0	–

**Note**

- $\overline{\text{RSTx}} = 0$  means reset condition if either  $\overline{\text{RSTO}}$  or  $\overline{\text{RSTC}}$  is asserted; '–' denotes not affected from reset line. During reset ( $\overline{\text{RST}}$ ,  $\overline{\text{RSTO}}$ ,  $\overline{\text{RSTC}}$ ) only those registers with an explicitly given reset value are affected. All other registers are undefined and have to be set by the controller.

## GSM signal processing IC

## PCF5083

Table 82 Hardware Control Register

BIT	R/W	SYMBOL	OPERATION (if bit is set)	$\overline{\text{RST}} = 0$	$\overline{\text{RSTx}} = 0^{(1)}$
0	R/W	AUXON_LH <sup>(2)</sup>	HWCTRL_INT activated from LOW-to-HIGH transition of input AUXON	–	0
1	R/W	AUXON_HL <sup>(2)</sup>	HWCTRL_INT activated from HIGH-to-LOW transition of input AUXON	–	0
2	R/W	ONKEY <sup>(2)</sup>	HWCTRL_INT activated from ONKEY input	–	0
3	R/W	LOWVOLT <sup>(2)</sup>	HWCTRL_INT activated from $\overline{\text{LOWVOLT}}$ input	–	0
4	R/W	CLOCK <sup>(2)</sup>	HWCTRL_INT activated from real time clock	–	0
5	R/W	ALARM <sup>(2)</sup>	HWCTRL_INT activated from alarm time match	–	0
6	R/W	SWOFF	Set to logic 1 for mobile switch off operation	0	0
7	R/W	SECINT	Select the real time clock interrupt to appear every second or every minute	0	0
8	R/W	SETCLOCK	Set to logic 1 to enable the real time clock to be set	0	0
9	R/W	MMIREQ <sup>(2)</sup>	HWCTRL_INT activated from a MMI controller service request via input MMIREQ	–	0
10	R/W	MMICLK	A logic 1 enables the MMI controller clock output (MMICLK)	1	1

## Notes

- $\overline{\text{RSTx}} = 0$  means reset condition if  $\overline{\text{RSTO}}$  is asserted; '–' denotes not affected from reset line. During reset ( $\overline{\text{RST}}$ ,  $\overline{\text{RSTO}}$ ) only those registers with an explicitly given reset value are affected. All other registers are undefined and have to be set by the controller.
- To clear these interrupt flags, the corresponding location has to be written with a logic 1.

Table 83 Real Time Clock registers

OFFSET	R/W	SYMBOL	SIZE	DESCRIPTION	$\overline{\text{RST}} = 0$	$\overline{\text{RSTx}} = 0^{(1)}$
30	R/W	SEC_REG	7	RTC: seconds	–	00
31	R/W	MIN_REG	7	RTC: minutes	–	00
32	R/W	HOUR_REG	6	RTC: hours	–	00
33	R/W	DAY_REG	3	RTC: day	–	00
34	R/W	DATE_REG	6	RTC: date	–	01
35	R/W	MONTH_REG	5	RTC: month	–	01
36	R/W	YEAR_REG	8	RTC: year	–	00
37	R/W	SEC_A_REG	7	RTC alarm function: seconds	–	–
38	R/W	MIN_A_REG	7	RTC alarm function: minutes	–	–
39	R/W	HOUR_A_REG	6	RTC alarm function: hours	–	–
3A	R/W	DAY_A_REG	3	RTC alarm function: day	–	–
3B	R/W	DATE_A_REG	6	RTC alarm function: date	–	–
3C	R/W	MONTH_A_REG	5	RTC alarm function: month	–	00
3D	R/W	YEAR_A_REG	8	RTC alarm function: year	–	–

## Note

- $\overline{\text{RSTx}} = 0$  means reset condition if  $\overline{\text{RSTC}}$  is asserted; '–' denotes not affected from reset line. During reset ( $\overline{\text{RST}}$ ,  $\overline{\text{RSTC}}$ ) only those registers with an explicitly given reset value are affected. All other registers are undefined and have to be set by the controller.



## GSM signal processing IC

## PCF5083

**Table 84** Combined Interrupt Register

BIT	R/W	SYMBOL	OPERATION (if bit is set)	$\overline{\text{RST}} = 0$	$\overline{\text{RSTx}} = 0^{(1)}$
0	R	HWCTRL_INT	HWCTRL_INT interrupt was activated.	–	–
1	R	IOM_INT	IOM_INT interrupt was activated.	–	–
2	R	SI_INT	SI_INT interrupt was activated.	–	–
3	R/W	HWCTRL_MASK	Enable the HWCTRL_INT interrupt to assert the COMB_INT interrupt line.	0	–
4	R/W	IOM_MASK	Enable the IOM_INT interrupt to assert the COMB_INT interrupt line.	0	–
5	R/W	SI_MASK	Enable the SI_INT interrupt to assert the COMB_INT interrupt line.	0	–

**Note**

1.  $\overline{\text{RSTx}} = 0$  means reset condition if either  $\overline{\text{RSTO}}$  or  $\overline{\text{RSTC}}$  is asserted; '–' denotes not affected from reset line. During reset ( $\overline{\text{RST}}$ ,  $\overline{\text{RSTO}}$ ,  $\overline{\text{RSTC}}$ ) only those registers with an explicitly given reset value are affected. All other registers are undefined and have to be set by the controller.

**Table 85** High Priority Interrupt Register

BIT	R/W	SYMBOL	OPERATION (if bit is set)	$\overline{\text{RST}} = 0$	$\overline{\text{RSTx}} = 0^{(1)}$
0	R/W	RX_INT <sup>(2)</sup>	Assert the $\overline{\text{HIPR\_INT}}$ interrupt line when the RX_REG is sent via the RF Bus.	0	–
1	R/W	RXTX_INT <sup>(2)</sup>	Assert the $\overline{\text{HIPR\_INT}}$ interrupt line when the TX_REG is sent via the RF Bus prior to a MON burst in the TX timeslot.	0	–
2	R/W	TX_INT <sup>(2)</sup>	Assert the $\overline{\text{HIPR\_INT}}$ interrupt line when the TX_REG is sent via the RF Bus prior to a TX burst.	0	–
3	R/W	MON_INT <sup>(2)</sup>	Assert the $\overline{\text{HIPR\_INT}}$ interrupt line when the MON_REG is sent via the RF Bus.	0	–
4	R/W	AS_INT1 <sup>(2)</sup>	Assert the $\overline{\text{HIPR\_INT}}$ interrupt line when the DACOFF_REG is sent via the RF Bus.	0	–
5	R/W	FRAME_INT <sup>(2)</sup>	Assert the $\overline{\text{HIPR\_INT}}$ interrupt line at the beginning of every TDMA frame.	0	–
6	R	PIRQN_INT	Assert the $\overline{\text{HIPR\_INT}}$ interrupt line if the DSP core host port input request is active.	0	–
7	R	PORQN_INT	Assert the $\overline{\text{HIPR\_INT}}$ interrupt line if the DSP core host port output request is active.	0	–

**Notes**

1.  $\overline{\text{RSTx}} = 0$  means reset condition if either  $\overline{\text{RSTO}}$  or  $\overline{\text{RSTC}}$  is asserted; '–' denotes not affected from reset line. During reset ( $\overline{\text{RST}}$ ,  $\overline{\text{RSTO}}$ ,  $\overline{\text{RSTC}}$ ) only those registers with an explicitly given reset value are affected. All other registers are undefined and have to be set by the controller.
2. To clear these interrupt flags, the corresponding location has to be written with a logic 1.

## GSM signal processing IC

## PCF5083

**Table 86** High priority interrupt mask register

BIT	R/W	SYMBOL	OPERATION (if bit is set)	$\overline{RST} = 0$	$\overline{RSTx} = 0^{(1)}$
0	R/W	RX_MASK	Enable the RX_INT flag to assert the $\overline{HIPR\_INT}$ interrupt line.	0	–
1	R/W	RXTX_MASK	Enable the RXTX_INT flag to assert the $\overline{HIPR\_INT}$ interrupt line.	0	–
2	R/W	TX_MASK	Enable the TX_INT flag to assert the $\overline{HIPR\_INT}$ interrupt line.	0	–
3	R/W	MON_MASK	Enable the MON_INT flag to assert the $\overline{HIPR\_INT}$ interrupt line.	0	–
4	R/W	AS_MASK	Enable the AS_INT flag to assert the $\overline{HIPR\_INT}$ interrupt line.	0	–
5	R/W	FRAME_MASK	Enable the FRAME_INT flag to assert the $\overline{HIPR\_INT}$ interrupt line.	0	–
6	R/W	PIRQN_MASK	Enable the PIRQN_INT flag to assert the $\overline{HIPR\_INT}$ interrupt line.	0	–
7	R/W	PORQN_MASK	Enable the PORQN_INT flag to assert the $\overline{HIPR\_INT}$ interrupt line.	0	–

**Note**

- $\overline{RSTx} = 0$  means reset condition if either  $\overline{RSTO}$  or  $\overline{RSTC}$  is asserted; '–' denotes not affected from reset line. During reset ( $\overline{RST}$ ,  $\overline{RSTO}$ ,  $\overline{RSTC}$ ) only those registers with an explicitly given reset value are affected. All other registers are undefined and have to be set by the controller.

**Table 87** Serial Interface Interrupt Register

BIT	R/W	SYMBOL	OPERATION (if bit is set)	$\overline{RST} = 0$	$\overline{RSTx} = 0^{(1)}$
0	R	IMC_OBE	RF Bus IMC channel output buffer empty.	0	–
1	R	IMC_IBF	RF Bus IMC channel input buffer full.	0	–
2	R	TXD_OBE	RS232 interface output buffer empty.	0	–
3	R	RXD_IBF	RS232 interface input buffer full.	0	–
4	R	EXT_IOM	External IOM <sup>®</sup> -2 interface request.	0	–
5	R	PAR_ERR	RS232 interface parity error.	0	–

**Note**

- $\overline{RSTx} = 0$  means reset condition if either  $\overline{RSTO}$  or  $\overline{RSTC}$  is asserted; '–' denotes not affected from reset line. During reset ( $\overline{RST}$ ,  $\overline{RSTO}$ ,  $\overline{RSTC}$ ) only those registers with an explicitly given reset value are affected. All other registers are undefined and have to be set by the controller.

## GSM signal processing IC

## PCF5083

**Table 88** Serial Interface Interrupt Mask Register

BIT	R/W	SYMBOL	OPERATION (if bit is set)	$\overline{\text{RST}} = 0$	$\overline{\text{RSTx}} = 0^{(1)}$
0	R/W	IMC_OBE_MASK	Enable the IMC_OBE flag to assert the SI_INT interrupt condition.	0	–
1	R/W	IMC_IBF_MASK	Enable the IMC_IBF flag to assert the SI_INT interrupt condition.	0	–
2	R/W	TXD_OBE_MASK	Enable the TXD_OBE flag to assert the SI_INT interrupt condition.	0	–
3	R/W	RXD_IBF_MASK	Enable the RXD_IBF flag to assert the SI_INT interrupt condition.	0	–
4	R/W	EXT_IOM_MASK	Enable the EXT_IOM flag to assert the SI_INT interrupt condition.	0	–

**Note**

- $\overline{\text{RSTx}} = 0$  means reset condition if either  $\overline{\text{RSTO}}$  or  $\overline{\text{RSTC}}$  is asserted; '–' denotes not affected from reset line. During reset ( $\overline{\text{RST}}$ ,  $\overline{\text{RSTO}}$ ,  $\overline{\text{RSTC}}$ ) only those registers with an explicitly given reset value are affected. All other registers are undefined and have to be set by the controller.

**Table 89** IOM<sup>®</sup>-2 Interface Configuration Register

BIT	R/W	SYMBOL	OPERATION (if bit is set)	$\overline{\text{RST}} = 0$	$\overline{\text{RSTx}} = 0^{(1)}$
0	R/W	IOMEXT_EN	Set to a logic 1 to enable the external IOM <sup>®</sup> -2 interface	0	–
1	R/W	IOMEXT_INV	Set to a logic 1 to invert the external IOM <sup>®</sup> -2 lines	0	–
2	R/W	CLOCK_MODE0	Select the IOM <sup>®</sup> -2 clock mode	0	–
3	R/W	CLOCK_MODE1		0	–
4	R/W	CLOCK_MODE2		0	–
5	R/W	DATA_MODE	Select the IOM <sup>®</sup> -2 data mode.	0	–
6	R/W	MASTER0_EN	Set to a logic 1 to enable the IOM <sup>®</sup> -2 master unit 0	0	–
7	R/W	MASTER1_EN	Set to a logic 1 to enable the IOM <sup>®</sup> -2 master unit 1	0	–
8	R/W	MASTER0_TS0	Select the IOM <sup>®</sup> -2 timeslot for the IOM <sup>®</sup> -2 master unit 0	0	–
9	R/W	MASTER0_TS1		0	–
10	R/W	MASTER0_TS2		0	–
11	R/W	MASTER0_TS3		0	–
12	R/W	MASTER1_TS0	Select the IOM <sup>®</sup> -2 timeslot for the IOM <sup>®</sup> -2 master unit 1	0	–
13	R/W	MASTER1_TS1		0	–
14	R/W	MASTER1_TS2		0	–
15	R/W	MASTER1_TS3		0	–

**Note**

- $\overline{\text{RSTx}} = 0$  means reset condition if either  $\overline{\text{RSTO}}$  or  $\overline{\text{RSTC}}$  is asserted; '–' denotes not affected from reset line. During reset ( $\overline{\text{RST}}$ ,  $\overline{\text{RSTO}}$ ,  $\overline{\text{RSTC}}$ ) only those registers with an explicitly given reset value are affected. All other registers are undefined and have to be set by the controller.

## GSM signal processing IC

## PCF5083

**Table 90** Audio Interface Configuration Register

BIT	R/W	SYMBOL	OPERATION (if bit is set)	$\overline{\text{RST}} = 0$	$\overline{\text{RSTx}} = 0^{(1)}$
0	R/W	TX_EN	Set to a logic 1 to enable the Voice Port transmit section	0	–
1	R/W	TX_DEST	Select Voice Port transmit section data port	0	–
2	R/W	RX_EN	Set to a logic 1 to enable the Voice Port receive section	0	–
3	R/W	RX_SOURCE	Select Voice Port receive section data port	0	–
4	R/W	TX_SLOT0	Select IOM <sup>®</sup> -2 timeslot for the Voice Port transmit section	0	–
5	R/W	TX_SLOT1		0	–
6	R/W	TX_SLOT2		0	–
7	R/W	TX_SLOT3		0	–
8	R/W	RX_SLOT0	Select IOM <sup>®</sup> -2 timeslot for the Voice Port receive section	0	–
9	R/W	RX_SLOT1		0	–
10	R/W	RX_SLOT2		0	–
11	R/W	RX_SLOT3		0	–
12	R/W	TRANS_EN	Set to a logic 1 to enable the Voice Port transparent mode	0	–

**Note**

- $\overline{\text{RSTx}} = 0$  means reset condition if either  $\overline{\text{RSTO}}$  or  $\overline{\text{RSTC}}$  is asserted; '–' denotes not affected from reset line. During reset ( $\overline{\text{RST}}$ ,  $\overline{\text{RSTO}}$ ,  $\overline{\text{RSTC}}$ ) only those registers with an explicitly given reset value are affected. All other registers are undefined and have to be set by the controller.

**Table 91** IOM<sup>®</sup>-2 Interface Interrupt Flag Register

BIT	R/W	SYMBOL	OPERATION (if bit is set)	$\overline{\text{RST}} = 0$	$\overline{\text{RSTx}} = 0^{(1)}$
0	R	MON0_IBF	Monitor master 0 input buffer full	0	–
1	R	MON0_OBE <sup>(2)</sup>	Monitor master 0 output buffer empty	0(1)	–
2	R	MON1_IBF	Monitor master 1 input buffer full	0	–
3	R	MON1_OBE <sup>(2)</sup>	Monitor master 1 output buffer empty	0(1)	–
4	R	CI0_IBF	C/I channel master 0 input buffer full	0	–
5	R	CI0_OBE <sup>(2)</sup>	C/I channel master 0 output buffer empty	0(1)	–
6	R	CI1_IBF	C/I channel master 1 input buffer full	0	–
7	R	CI1_OBE <sup>(2)</sup>	C/I channel master 1 output buffer empty	0(1)	–

**Notes**

- $\overline{\text{RSTx}} = 0$  means reset condition if either  $\overline{\text{RSTO}}$  or  $\overline{\text{RSTC}}$  is asserted; '–' denotes not affected from reset line. During reset ( $\overline{\text{RST}}$ ,  $\overline{\text{RSTO}}$ ,  $\overline{\text{RSTC}}$ ) only those registers with an explicitly given reset value are affected. All other registers are undefined and have to be set by the controller.
- These flags change from '0' to '1' after the IOM<sup>®</sup>-2 interface was enabled with  $\text{CLOCK\_MODE} = 0$  and  $\text{MASTERx\_EN} = '0'$  after the state machined of the monitor/CI master units are in an initial state.

## GSM signal processing IC

## PCF5083

**Table 92** IOM<sup>®</sup>-2 Interface Control Register

BIT	R/W	SYMBOL	OPERATION (if bit is set)	$\overline{\text{RST}} = 0$	$\overline{\text{RST}}_x = 0^{(1)}$
0	R/W	TABORT0	Monitor master 0 transmit abort request	0	–
1	R/W	TABORT1	Monitor master 1 transmit abort request	0	–
2	R	RABORT0	Monitor master 0 receive abort request	0	–
3	R	RABORT1	Monitor master 1 receive abort request	0	–
4	R/W	TEOM0	Monitor master 0 transmit end of message	0	–
5	R/W	TEOM1	Monitor master 1 transmit end of message	0	–
6	R	REOM0	Monitor master 0 receive end of message	0	–
7	R	REOM1	Monitor master 1 receive end of message	0	–

**Note**

1.  $\overline{\text{RST}}_x = 0$  means reset condition if either  $\overline{\text{RSTO}}$  or  $\overline{\text{RSTC}}$  is asserted; '–' denotes not affected from reset line. During reset ( $\overline{\text{RST}}$ ,  $\overline{\text{RSTO}}$ ,  $\overline{\text{RSTC}}$ ) only those registers with an explicitly given reset value are affected. All other registers are undefined and have to be set by the controller.

**Table 93** IOM<sup>®</sup>-2 Interface Interrupt Enable Register

BIT	R/W	SYMBOL	OPERATION (if bit is set)	$\overline{\text{RST}} = 0$	$\overline{\text{RST}}_x = 0^{(1)}$
0	R/W	MON0_IBF_EN	Enable the MON0_IBF flag to assert the IOM_INT interrupt condition.	0	–
1	R/W	MON0_OBE_EN	Enable the MON0_OBE flag to assert the IOM_INT interrupt condition.	0	–
2	R/W	MON1_IBF_EN	Enable the MON1_IBF flag to assert the IOM_INT interrupt condition.	0	–
3	R/W	MON1_OBE_EN	Enable the MON1_OBE flag to assert the IOM_INT interrupt condition.	0	–
4	R/W	CI0_IBF_EN	Enable the CI0_IBF flag to assert the IOM_INT interrupt condition.	0	–
5	R/W	CI0_OBE_EN	Enable the CI0_OBE flag to assert the IOM_INT interrupt condition.	0	–
6	R/W	CI1_IBF_EN	Enable the CI1_IBF flag to assert the IOM_INT interrupt condition.	0	–
7	R/W	CI1_OBE_EN	Enable the CI1_OBE flag to assert the IOM_INT interrupt condition.	0	–

**Note**

1.  $\overline{\text{RST}}_x = 0$  means reset condition if either  $\overline{\text{RSTO}}$  or  $\overline{\text{RSTC}}$  is asserted; '–' denotes not affected from reset line. During reset ( $\overline{\text{RST}}$ ,  $\overline{\text{RSTO}}$ ,  $\overline{\text{RSTC}}$ ) only those registers with an explicitly given reset value are affected. All other registers are undefined and have to be set by the controller.

## GSM signal processing IC

## PCF5083

**Table 94** Parallel Port Data Register

BIT	R/W	SYMBOL	OPERATION	$\overline{\text{RST}} = 0$	$\overline{\text{RSTx}} = 0^{(1)}$
0 to 5	R/W	PIO0_DATA to PIO5_DATA	PIO0 to PIO5 input or output data	0	–

**Note**

- $\overline{\text{RSTx}} = 0$  means reset condition if either  $\overline{\text{RSTO}}$  or  $\overline{\text{RSTC}}$  is asserted; '–' denotes not affected from reset line. During reset ( $\overline{\text{RST}}$ ,  $\overline{\text{RSTO}}$ ,  $\overline{\text{RSTC}}$ ) only those registers with an explicitly given reset value are affected. All other registers are undefined and have to be set by the controller.

**Table 95** Parallel Port Data Direction Register

BIT	R/W	SYMBOL	OPERATION	$\overline{\text{RST}} = 0$	$\overline{\text{RSTx}} = 0^{(1)}$
0	R	PIO0_DIR	reserved	0	–
1 to 5	R/W	PIO1_DIR to PIO5_DIR	A logic 1 selects the port as an output. A logic 0 selects the port as an input.	0	–

**Note**

- $\overline{\text{RSTx}} = 0$  means reset condition if either  $\overline{\text{RSTO}}$  or  $\overline{\text{RSTC}}$  is asserted; '–' denotes not affected from reset line. During reset ( $\overline{\text{RST}}$ ,  $\overline{\text{RSTO}}$ ,  $\overline{\text{RSTC}}$ ) only those registers with an explicitly given reset value are affected. All other registers are undefined and have to be set by the controller.

**Table 96** System Configuration Register (SYSCON)

BIT	R/W	SYMBOL	OPERATION (if bit is set)	$\overline{\text{RST}} = 0$	$\overline{\text{RSTx}} = 0^{(1)}$
0	W	CLK13M	Disable the CLK13M output pin.	0	–
1	W	CLK20M	Disable the CLK20M output pin.	0	–
2	W	CLK32K	Disable the CLK32K output pin; PCF5083-2B and PCF5083-2C only.	0	–
		CLK26M	Disable the CLK26M output pin; PCF5083-3A only.	0	–
3	W	DSP_CLK0	These two bits select the DSP core input clock.	0	–
4	W	DSP_CLK1		0	–
5	W	RS232_CLK	Select the external clock for the RS232 interface	0	–
6	R	LOCK	When a logic 1, the PLL is out of lock. When a logic 0, the PLL is in lock.	0	–

**Note**

- $\overline{\text{RSTx}} = 0$  means reset condition if either  $\overline{\text{RSTO}}$  or  $\overline{\text{RSTC}}$  is asserted; '–' denotes not affected from reset line. During reset ( $\overline{\text{RST}}$ ,  $\overline{\text{RSTO}}$ ,  $\overline{\text{RSTC}}$ ) only those registers with an explicitly given reset value are affected. All other registers are undefined and have to be set by the controller.

GSM signal processing IC

PCF5083

10.2 Interrupt Logic

The PCF5083 provides three active LOW interrupt lines: FRAME\_INT, COMB\_INT and HIPR\_INT for use with the microcontroller. These interrupt lines are described in Table 97.

Table 97 Interrupt lines

INTERRUPT	DESCRIPTION
FRAME_INT	This output generates an interrupt at the beginning of every TDMA frame. The interrupt is deactivated with an access to register MODE0_REG.
COMB_INT	<p>This output combines three different interrupts:</p> <p>HWCTRL_INT: indicates all interrupts from the on/off monitor, MMI power-down unit and the real time clock. All these interrupt sources are encoded in register HWCTRL_REG</p> <p>IOM_INT: indicates all interrupts from the IOM<sup>®</sup>-2 interface encoded in registers IOMFLAG_REG and IOMCTRL_REG. Enable flags for this interrupt source are provided in register IOMEN_REG.</p> <p>SI_INT: indicates all interrupts from the RF-IC bus interface and the RS232 interface encoded in register SIINT_REG. Enable flags for this interrupt source are provided in register SIMASK_REG.</p> <p>The register COMBINT_REG contains an interrupt flag and an enable flag for each of the three interrupts. The interrupt flags are inactive if none of their corresponding interrupt conditions is active and enabled.</p>
HIPR_INT	This outputs combines some high priority interrupt sources derived from the RF-IC bus trigger signals generated from the timing generator, from the TDMA frame interrupt and the host port of the DSP core. The register HIPRINT_REG holds flags for each interrupt condition and the register HIPRMASK_REG the corresponding interrupt enable flags. For further details refer to Section 10.1

11 RESET

The PCF5083 has three asynchronous, active LOW reset inputs: RSTO, RSTC and RST.

RSTO resets the ON/OFF monitor. RSTC the real time clock unit. For a proper reset, RSTO and RSTC have to be asserted until the 32.768 kHz oscillator has stabilized.

RST controls all other parts of the PCF5083. RST is connected to the system reset. For a proper reset, RST has to be asserted for at least 62.5 ms.

After powering-up the PCF5083 all reset lines RSTO, RSTC and RST must be asserted to achieve a defined state of the IC.

The DSP core reset is driven via the general purpose parallel port bit 0. After an external reset via RST, this port pin is set to a logic 0. The DSP core is therefore set into the reset state.

12 JTAG TEST INTERFACE

The PCF5083 JTAG interface is used to increase testability at board level. The interface is implemented in accordance with IEEE Std 1149.1-1990, IEEE Standard Test Access Port and Boundary-Scan Architecture.

The interface signals are specified in Table 98 and the operations supported by the interface are given in Table 99.

Table 98 JTAG test interface signals

SIGNAL	DESCRIPTION
TRSTN	Test Reset, active LOW input. This signal resets the internal TAP controller and the state of the boundary-scan cells. It must be pulled LOW during normal operation to ensure that the boundary scan circuitry does not influence the application logic.
TCK	Test Clock input.
TMS	Test Mode Select input. This signal controls the internal state machine of the TAP controller.
TDI	Test Data Input to shift in instructions and data are applied to the boundary-scan circuitry.
TDO	Test Data Out. While shifting in data at the port TDI, data in also shifted out serially at this pin. The instruction register and the data registers are always connected between TDI and TDO.

## GSM signal processing IC

## PCF5083

**Table 99** Operations supported by the JTAG-circuitry

INSTRUCTION	BINARY CODE	DESCRIPTION OR VALUE
EXTEST	00000	Refer to IEEE standard
ACUTEST <sup>(1)</sup>	00001	Test mode for IC production
CONTEST <sup>(1)</sup>	00010	Test mode for IC production
DCUTEST <sup>(1)</sup>	00011	Test mode for IC production
IOTEST <sup>(1)(1)</sup>	00100	Test mode for IC production
FCTTEST <sup>(1)</sup>	00101	Test mode for IC production
SFTTEST <sup>(1)</sup>	00110	Test mode for IC production
FCTTESTV <sup>(1)</sup>	00111	Test mode for IC production
SAMPLE/PRELOAD	01000	Refer to IEEE standard
RESET <sup>(1)</sup>	10000	Generate a synchronous reset for the DSP core
GO <sup>(1)</sup>	10001	Restart the DSP core at 0x0000 after the RESET instruction
HIGH-Z	10010	Sets all 3-state pins in their high impedance state; TDI, TDO equal to BYPASS
CLAMP	10011	Pins like EXTEST. TDI, TDO equal to BYPASS
NMI <sup>(1)</sup>	10100	Generate a NMI to the DSP core
–	10110	Reserved
–	10111	Reserved
TESTIN <sup>(1)</sup>	11000	Select the test input register TI
TESTOUT <sup>(1)</sup>	11001	Select the test output register TO
STATUS	11010	Select the status register
IDCODE <sup>(2)</sup>	11101	0001 0101110110000110 00000010101 1 (PCF5083-1)
		0010 0101110110000110 00000010101 1 (PCF5083-2)
		0011 0101110110000110 00000010101 1 (PCF5083-3)
BYPASS <sup>(3)</sup>	Others	Refer to IEEE standard

**Notes**

1. For all DSP core specific instructions refer to [1].
2. This instruction is always captured in the state Capture\_IR of the TAP controller.
3. This instruction is loaded into the instruction register in the state Reset of the TAP-controller.



## GSM signal processing IC

## PCF5083

Table 100 Boundry Scan Chain

NO.	SIGNAL	I/O	3-STATE CONTROL
<b>TDI</b>			
1	REFON	output	105
2	DCLK	input	
3	RSTP	input	
4	CLKSEL	input	
5	CKI	input	
6	cki_enable	output	note 1
7	HCEN_T	input	
8	IO1	output	9
9	io1_enable	output	
10	IO1	input	
11	IO2	output	12
12	io2_enable	output	
13	IO2	input	
14	IO3	output	15
15	io3_enable	output	
16	IO3	input	
17	IO4	output	18
18	io4_enable	output	
19	IO4	input	
20	HA0	input	
21	HA1	input	
22	HA2	input	
23	HA3	input	
24	HA4	input	
25	HA5	input	
26	HA6	input	
27	hd_enable	output	
28	HD0	output	27
29	HD0	input	
30	HD1	output	27
31	HD1	input	
32	HD2	output	27
33	HD2	input	

NO.	SIGNAL	I/O	3-STATE CONTROL
34	HD3	output	27
35	HD3	input	
36	HD4	output	27
37	HD4	input	
38	HD5	output	27
39	HD5	input	
40	HD6	output	27
41	HD6	input	
42	HD7	output	27
43	HD7	input	
44	HR/W	input	
45	HCEN_D	input	
46	DTACK (_enable)	output	46; note 2
47	SIXCLK	input	
48	SIXEN	input	
49	SIXD	input	
50	SOXCLK	input	
51	SOXEN	input	
52	SOXD	output	53
53	soxd_enable	output	
54	CLK20M	output	105
55	FRAME_INT (_enable)	output	55; note 2
56	COMB_INT (_enable)	output	56; note 2
57	HIPR_INT (_enable)	output	57; note 2
58	CLK13M	output	105
59	AFS	input	60
60	afs_enable	output	
61	AFS	output	
62	ACLK	output	63
63	aclk_enable	output	
64	ACLK	input	
65	ADI	input	
66	ADO	output	103
67	TSCK1	input	

## GSM signal processing IC

## PCF5083

NO.	SIGNAL	I/O	3-STATE CONTROL
68	TSCK2	input	
69	TCE	input	
70	PIO1	input	
71	PIO1	output	72
77	pio1_enable	output	
73	PIO2	input	
74	PIO2	output	75
75	pio2_enable	output	
76	PIO3	input	
77	PIO3	output	78
78	pio3_enable	output	
79	PIO4	input	
80	PIO4	output	81
81	pio4_enable	output	
82	PIO5	input	
83	PIO5	output	84
84	pio5_enable	output	
85	BEN	output	103
86	TXON	output	103
87	RXON	output	103
88	PDRX1	output	103
89	PDRX2	output	103
90	PDTX1	output	103
91	NPDTX1	output	103
92	NPDTX2	output	103
93	PDBIAS	output	103
94	NPDBIAS	output	103
95	PDSYN	output	103
96	TXKEY1	output	103
97	TXKEY2	output	103
98	DSPEN	input	
99	TIMEN	input	
100	RSTC	input	
101	RSTO	input	
102	ONKEY	input	
103	gpon1_enable	output	
104	CLK32I	input	
105	powon_enable	output	

NO.	SIGNAL	I/O	3-STATE CONTROL
106	AUXON	input	
107	LOWVOLT	output	
108	POWON	output	
109	NPOWON	output	
110	RST	input	
111	CLK32K; note 3	output	105
	CLK26M; note 4		
112	TXD (_enable)	output	112; note 2
113	RXD	input	
114	MMIEN (_enable)	output	114; note 2
115	MMIREQ	input	
116	MMICLK	output	105
117	FSC	input	
118	FSC	output	119
119	fsc_dcl_enable	output	
120	DCL	input	
121	DCL	output	119
122	DU	input	
123	DD (_enable)	output	123; note 2
124	RFCLK	output	103
125	RFEN1	output	103
126	RFEN2	output	103
127	RFEN3	output	103
128	RFEN4	output	103
129	RFDI	input	
130	RFDO	output	103
131	RFE	output	103
132	NREFON	output	105
133	GPON1	output	105
<b>TDO</b>			
134	GPON1 (_enable)	output	134; note 2

**Notes**

1. H: enable CKI pad to scan cell; L: CKI reads High.
2. Open-drain output.
3. PCF5083-2B and PCF5083-2C versions only.
4. PCF5083-3 only.

## GSM signal processing IC

## PCF5083

**13 TEST AND EMULATION MODES**

The PCF5083 supports two test and emulation modes which make all internal signals of the DSP or Timer core externally available. These test modes are selected with either DSPEN = 1 and TIMEN = 0, or DSPEN = 0 and TIMEN = 1.

More information on these test modes will be made available with application notes. Ask your local sales office about the status of these application notes.

**14 LIMITING VALUES**

In accordance with the Absolute Maximum Rating System (IEC 134).

SYMBOL	PARAMETER	MIN.	MAX.	UNIT
$V_{DD}$	supply voltage	-0.5	+5.0	V
$V_I$	input voltage on any pin with respect to ground ( $V_{SS}$ )	-0.5	$V_{DD} + 0.5V$	V
$I_I$	sink current into any pin	-20	+20	mA
$P_{tot}$	total power dissipation	-	800	mW
$T_{stg}$	storage temperature	-65	+150	°C
$T_{amb}$	operating ambient temperature	-40	+85	°C

**Notes**

- Stresses above those listed under Maximum Absolute Ratings may cause permanent damage to the device. This is a stress rating only and functional operation of the device at these or any other condition above those indicated in the operation section of this specification is not implied.
- For operating at elevated temperatures the device must be derated based on 125 °C maximum junction temperature.
- This product includes circuitry specifically designed for the protection of its internal devices from the damaging effects of excessive static charge. Nonetheless, it is suggested that conventional precautions be taken to avoid applying any voltage larger than the rated maxima.

**15 DC CHARACTERISTICS**

$T_{amb} = -40$  to  $+85$  °C;  $V_{DD} = 3.3 V \pm 10\%$ .

SYMBOL	PARAMETER <sup>(1)</sup>	CONDITIONS	MIN.	TYP.	MAX.	UNIT
<b>Supply</b>						
$V_{DD}$	operating supply voltage		2.7	3.0	3.6	V
$I_{DD}$	operating supply current	all sections operating; Timer active, DSP encoding speech; note 2				
	$I_{(VDD2)} + I_{(VDDPLL)}$		-	40	50	mA
	$I_{(VDD1)}$	note 3	-	8	-	mA
$I_{DDtot}$	$I_{(VDD2)} + I_{(VDDPLL)} + I_{(VDD1)}$		-	48	-	mA
$I_{DD(SLP)}$	supply current Sleep mode	Timer sleeping, DSP inactive				
	$I_{(VDD2)} + I_{(VDDPLL)}$		-	250	500	µA
	$I_{(VDD1)}$	note 3	-	340	-	µA
$I_{DD(SLP)tot}$	$I_{(VDD2)} + I_{(VDDPLL)} + I_{(VDD1)}$		-	590	-	µA

## GSM signal processing IC

## PCF5083

SYMBOL	PARAMETER <sup>(1)</sup>	CONDITIONS	MIN.	TYP.	MAX.	UNIT
I <sub>DD(STBY)</sub>	supply current Standby mode	ON/OFF logic and RTC active				
	I <sub>(VDD2)</sub> + I <sub>(VDDPLL)</sub>		–	15	100	μA
	I <sub>(VDD1)</sub>	note 3	–	245	–	μA
I <sub>DD(STBY)tot</sub>	I <sub>(VDD2)</sub> + I <sub>(VDDPLL)</sub> + I <sub>(VDD1)</sub>		–	260	–	μA
<b>All inputs except CK32I, CKI and Schmitt trigger inputs</b>						
V <sub>IL</sub>	LOW level input voltage		–	–	0.3V <sub>DD</sub>	V
V <sub>IH</sub>	HIGH level input voltage		0.7V <sub>DD</sub>	–	V <sub>DD</sub>	V
I <sub>IL</sub>	LOW level sink current without pull-down resistor	V <sub>IN</sub> = 0	–	–	1	μA
I <sub>IH</sub>	HIGH level source current with pull-down resistor	V <sub>IN</sub> = V <sub>DD</sub>	40	150	250	μA
I <sub>ZL</sub>	3-state output leakage current	V <sub>O</sub> = 0 to V <sub>DD</sub>	–	–	1	μA
<b>All outputs</b>						
V <sub>OL</sub>	LOW level output voltage		–	–	0.4	V
V <sub>OH</sub>	HIGH level output voltage (except open-drain outputs)		0.8V <sub>DD</sub>	–	–	V
I <sub>LI</sub>	open-drain output leakage current	V <sub>O</sub> = 0 to V <sub>DD</sub>	–	–	1	μA
<b>CMOS Schmitt trigger inputs</b>						
V <sub>IL</sub>	LOW level input voltage		0	–	0.25V <sub>DD</sub>	V
V <sub>IH</sub>	HIGH level input voltage		0.75V <sub>DD</sub>	–	V <sub>DD</sub>	V
V <sub>HYS</sub>	Hysteresis		–	0.7	–	V
<b>CK32I</b>						
I <sub>IL</sub>	LOW level sink current	V <sub>IN</sub> = 0; CK32O open	–	–	1	μA
I <sub>IH</sub>	HIGH level source current	V <sub>IN</sub> = V <sub>DD</sub> ; CK32O open	–	–	1	μA
C <sub>in</sub>	input capacitance		–	20	–	pF
g <sub>m</sub>	32 kHz oscillator transconductance	CK32I = CK32O = 0.6V <sub>DD</sub>	5	–	25	μS
<b>CKI</b>						
V <sub>IN</sub>	input voltage swing	DC bias = 0.35V <sub>DD</sub> (internally generated)	0.7	–	V <sub>DD</sub> – V <sub>SS</sub>	V

**Notes**

- V<sub>DD1</sub> = pad ring power supply; V<sub>DD2</sub> = core power supply and V<sub>DDPLL</sub> = analog PLL power supply.
- Current consumption during active speech encoding is measured and then derated by 0.8 to reflect activity level during one cycle.
- I<sub>DD1</sub> is estimated with a 30 pF load on each output.

## GSM signal processing IC

## PCF5083

**16 AC CHARACTERISTICS**

$T_{amb} = -40$  to  $+85$  °C;  $V_{DD} = 3.3$  V  $\pm 10\%$ ; see notes 1 to 4.

NO	PARAMETER	MIN.	TYP.	MAX.	UNIT
<b>13 MHz clock timing</b> (see Figs 22 and 24; note 5)					
1	CKI HIGH time	20	–	–	ns
2	CKI LOW time	20	–	–	ns
3	CKI frequency ( $1/t_{13}$ )	–	13	–	MHz
4	CLK13M HIGH to CKI HIGH delay	–	30	–	ns
5	CLK13M LOW to CKI LOW delay	–	30	–	ns
6	MMICKL HIGH to CKI HIGH delay	–	30	–	ns
7	MMICKL LOW to CKI LOW delay	–	30	–	ns
–	PLL lock time with respect to $\overline{RSTP}$ HIGH	–	–	50	$\mu$ s
<b>32 kHz clock timing</b> (see Figs 25 and 26; note 6)					
3	CLK32K frequency	–	32.768	–	kHz
<b>26 MHz clock timing</b> (see Fig.23; notes 5 and 7)					
1	CLK26M HIGH time	5	–	–	ns
2	CLK26M LOW time	5	–	–	ns
3	CLK26M frequency	–	26	–	MHz
<b>DSP and RS232 clock timing</b> (see Figs 27 and 28; note 6)					
1	DCLK frequency; note 8	–	–	39	MHz
2	DCLK HIGH time	10	–	–	ns
3	DCLK LOW time	10	–	–	ns
4	External RS232 Interface clock frequency - 19200 Baud (provided via ADI and selected with SYSCON_REG[RS232_CLK] = 1)	–	11.0592	–	MHz
5	External RS232 Interface clock HIGH time	–	90.4	–	ns
6	External RS232 Interface clock LOW time	–	90.4	–	ns

## GSM signal processing IC

PCF5083

NO	PARAMETER	MIN.	TYP.	MAX.	UNIT
<b>Host Interface timing</b> (see Figs 29 and 30)					
1	HR/W setup time to $\overline{\text{HCEN}}$ LOW	5	–	–	ns
2	HA0 to HA6 setup time to $\overline{\text{HCEN}}$ LOW	5	–	–	ns
3a	HD0 to HD7 setup time ( $\overline{\text{HCEN\_T}}$ )	$t_{13}$	–	–	ns
3b	HD0 to HD7 setup time ( $\overline{\text{HCEN\_D}}$ )	10	–	–	ns
4	HD0 to HD7 hold time after $\overline{\text{HCEN}}$ HIGH	10	–	–	ns
5	HR/W hold time after $\overline{\text{HCEN}}$ HIGH	5	–	–	ns
6	HA0 to HA6 hold time after $\overline{\text{HCEN}}$ HIGH	10	–	–	ns
7a	$\overline{\text{HCEN}}$ pulse width ( $\overline{\text{HCEN\_T}}$ )	$3t_{13}$	–	–	ns
7b	$\overline{\text{HCEN}}$ pulse width ( $\overline{\text{HCEN\_D}}$ )	$2t_{\text{dclkout}} + 20$	–	–	ns
8 <sup>(9)</sup>	$\overline{\text{DTACK}}$ LOW delay time, DSP write cycle	–	30	–	ns
9	$\overline{\text{DTACK}}$ HIGH delay time, DSP read cycle; note 3	–	40	–	ns
10 <sup>(10)</sup>	$\overline{\text{DTACK}}$ LOW delay time, DSP read cycle	–	30	–	ns
11	$\overline{\text{DTACK}}$ LOW to data valid; note 11	–	35	50	ns
12	$\overline{\text{DTACK}}$ HIGH delay time, DSP read cycle; note 3	–	40	–	ns
13a	HD0 to HD7 valid after $\overline{\text{HCEN}}$ LOW ( $\overline{\text{HCEN\_T}}$ )	–	–	$3t_{13}$	ns
13b	HD0 to HD7 valid after $\overline{\text{HCEN}}$ LOW ( $\overline{\text{HCEN\_D}}$ )	–	–	45	ns
14	HD0 to HD7 3-state after $\overline{\text{HCEN}}$ HIGH	–	–	30	ns
<b>RF Device Control Bus timing - Mode 0</b> (see Fig.31; note 12)					
1	RFEN1 to RFEN4 setup time to RFCLK LOW	–	$4t_{13}$	–	ns
2	RFEN1 to RFEN4 hold time after RFCLK HIGH	–	$2t_{13}$	–	ns
3	RFCLK HIGH time	–	$6t_{13}$	–	ns
4	RFCLK LOW time	–	$6t_{13}$	–	ns
5	RFDO setup time to RFCLK HIGH	–	$10t_{13}$	–	ns
6	RFDO hold time after RFCLK HIGH	–	$2t_{13}$	–	ns
7 <sup>(7)</sup>	RFDI setup time to RFCLK HIGH	70	–	–	ns
<b>RF Device Control Bus timing - Mode 1</b> (see Fig.32; note 12)					
1	RFEN1 to RFEN4 setup time to RFCLK HIGH	–	$4t_{13}$	–	ns
2	RFEN1 to RFEN4 hold time after RFCLK LOW	–	$2t_{13}$	–	ns
3	RFCLK LOW time	–	$6t_{13}$	–	ns
4	RFCLK HIGH time	–	$6t_{13}$	–	ns
5	RFDO setup time to RFCLK HIGH	–	$4t_{13}$	–	ns
6	RFDO hold time after RFCLK LOW	–	$2t_{13}$	–	ns
7 <sup>(7)</sup>	RFDI setup time to RFCLK LOW	70	–	–	ns

## GSM signal processing IC

PCF5083

NO	PARAMETER	MIN.	TYP.	MAX.	UNIT
<b>RF Device Control Bus timing - Mode 2</b> (see Fig.33; note 12)					
1	RFEN1 to RFEN4 setup time to RFCLK HIGH	–	4t <sub>13</sub>	–	ns
2	RFEN1 to RFEN4 hold time after RFCLK LOW	–	14t <sub>13</sub>	–	ns
3	RFCLK LOW time	–	6t <sub>13</sub>	–	ns
4	RFCLK HIGH time	–	6t <sub>13</sub>	–	ns
5	RFDO setup time to RFCLK HIGH	–	4t <sub>13</sub>	–	ns
6	RFDO hold time after RFCLK LOW	–	2t <sub>13</sub>	–	ns
7 <sup>(7)</sup>	RFDI setup time to RFCLK LOW	70	–	–	ns
8	RFE setup time to RFEN1 to RFEN4 LOW	–	6t <sub>13</sub>	–	ns
<b>Baseband Interface timing (DSP Core X_Port)</b> (see Fig.34)					
1	SIXEN setup to SIXCLK HIGH	5	–	–	ns
2	SIXD setup to SIXCLK HIGH	5	–	–	ns
3	SIXD hold time after SIXCLK HIGH	10	–	–	ns
4	SIXEN hold time after SIXCLK HIGH	10	–	–	ns
5	SIXCLK frequency	–	13	–	MHz
6	SIXCLK LOW time	20	–	–	ns
7	SIXCLK HIGH time	20	–	–	ns
8	SOXEN setup time to SOXCLK LOW	20	–	–	ns
10	SOXD hold time after SOXCLK LOW	–	–	40	ns
11	SOXEN hold time after SOXCLK LOW	10	–	–	ns
12	SOXD 3-state after SOXEN HIGH	–	–	20	ns
13	SOXCLK frequency	–	0.27	13	MHz
14	SOXCLK LOW time	20	1800	–	ns
15	SOXCLK HIGH time	20	1800	–	ns
<b>IOM -2 Interface timing</b> (see Figs 35 and 36)					
1 <sup>(7)</sup>	DD hold time after DCL HIGH	–30	–	30	ns
2a <sup>(13)</sup>	DCL cycle time	–	8.5t <sub>13</sub>	–	ns
2b <sup>(13)</sup>	DCL cycle time	–	8t <sub>13</sub>	–	ns
2c <sup>(13)</sup>	DCL frequency	–	4.096	–	MHz
3 <sup>(7)</sup>	FSC hold time after DCL HIGH	–30	–	30	ns
4 <sup>(7)</sup>	DU setup time to DCL LOW	50	–	–	ns
5 <sup>(7)</sup>	DU hold time after DCL LOW	50	–	–	ns
6 <sup>(13)(7)</sup>	DCL HIGH time	75	–	–	ns
7 <sup>(13)(7)</sup>	DCL LOW time	75	–	–	ns

## GSM signal processing IC

PCF5083

NO	PARAMETER	MIN.	TYP.	MAX.	UNIT
<b>Voice Port timing - non-transparent mode</b> (see Fig.37 and note 14)					
1 <sup>(7)</sup>	AFS setup time to ACLK HIGH	200	–	–	ns
2 <sup>(7)</sup>	AFS hold time after ACLK LOW	10	–	–	ns
3 <sup>(7)</sup>	ADO hold time after ACLK HIGH	–	–	30	ns
4 <sup>(7)</sup>	ADI setup time to ACLK LOW	30	–	–	ns
5 <sup>(7)</sup>	ADI hold time to ACLK LOW	40	–	–	ns
6 <sup>(7)</sup>	ACLK frequency	–	–	1	MHz
7 <sup>(7)</sup>	ACLK HIGH time	400	–	–	ns
8 <sup>(7)</sup>	ACLK LOW time	400	–	–	ns
<b>JTAG Port timing</b> (see Fig.38)					
1	TCK LOW time	35	–	–	ns
2	TCK HIGH time	25	–	–	ns
3	TCK cycle time	–	–	10	ns
4	TMS setup time to TCK HIGH	10	–	–	ns
5	TMS hold time after TCK HIGH	30	–	–	ns
6	TDI setup time to TCK HIGH	5	–	–	ns
7	TDI hold time after TCK HIGH	30	–	–	ns
8	TDO asserted after TCK LOW	–	–	60	ns
9	TDO hold time after TCK LOW	–	–	60	ns
10	TDO 3-state after TCK LOW	–	–	30	ns
11	TRSTN pulse width	100	–	–	ns
<b>General purpose parallel port</b> (see Fig.39)					
1	PIO data valid after CLK13M rising edge (output)	–	70	–	ns
2	PIO data setup time	–	10	–	ns
3	PIO data valid after CLK13M rising edge (input)	–	70	–	ns
<b>All outputs</b>					
t <sub>r</sub> <sup>(7)</sup>	rise time	–	–	20	ns
t <sub>f</sub> <sup>(7)</sup>	fall time	–	–	20	ns



---

**GSM signal processing IC****PCF5083**

---

**Notes to the AC characteristics**

- Parameters are valid over the specified temperature range.
- All voltages are measured with respect to ground ( $V_{SS}$ ). For testing all inputs swing between 0 V and  $V_{DD}$  with a transition time of 4 ns. All time measurements are made with input voltages of 0 V and  $V_{DD}$  and output voltages of  $0.2V_{DD}$  and  $0.8V_{DD}$  as appropriate.
- Test conditions for outputs:  $C_L = 40$  pF, except open-drain outputs. Test conditions for open-drain outputs:  $C_L = 40$  pF;  $I_L = 1.8$  mA at  $V_{DD}$ .
- All timing diagrams should only be referred to in regard to the edge-to-edge measurements of the timing specifications. They are not intended as a functional description of the input and output signals. Refer to the functional description and related timing diagrams for device operation. All setup and hold times are specified with respect to  $V_{IH}$  and  $V_{IL}$ . All delay times with respect to  $0.5V_{DD}$ . Times with only typical values are not tested during IC production
- For testing the AC characteristics, the low swing input CKI is driven with a square wave signal of the specified minimum peak-to-peak input voltage swing. The typical values for additional components are:  $C_1 = 4.7$  nF,  $C_2 = 100$  pF and  $R_1 = 10$  k $\Omega$ .
- For testing the AC characteristics, the input CLK32I is driven with a standard test signal (see note 2). A typical application for crystal operation is:  $R = 10$  M $\Omega$ ,  $f_Q = 32.768$  kHz,  $C_1 = 15$  pF,  $C_T = 15$  pF (for crystal  $C_L = 12.5$  pF).
- These times are guaranteed by design and are not tested during IC production.
- DCLK internally divided-by-two to drive the DSP;  $t_{DCLKOUT} = \frac{1}{2}DCLK$ .
- This time specified is when PI is empty.
- This time specified is when PO is full.
- Not tested in production.
- Mode 0 and 1, or Mode 2 are selected by register settings. Refer to the functional specification.
- The output DCL has two different cycle times depending on the DCL period number. Refer to the functional description. The table lists the cycle times for the 1.536 MHz internal clock mode and the maximum clock frequency in external clock mode. The minimum cycle times correspond to the 4.096 MHz external clock mode and therefore apply to all the external clock modes.
- The Audio Interface timing is given for the non-transparent mode. In transparent mode the IOM<sup>®</sup>-2 Interface timing applies to the Audio Interface accordingly, refer to functional description.

GSM signal processing IC

PCF5083

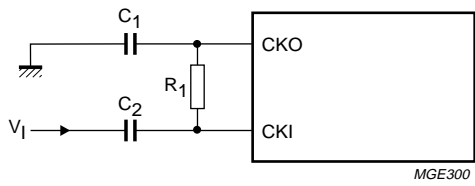

Fig.22 13 MHz Clock circuit.

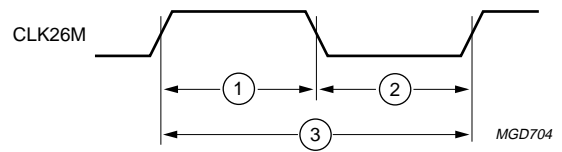

Fig.23 CLK26M Clock timing.

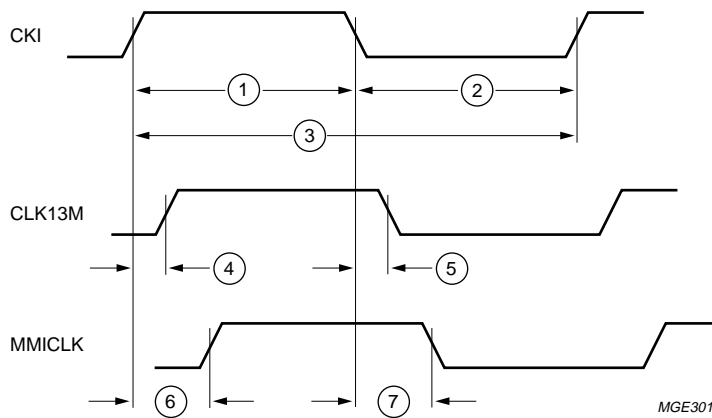
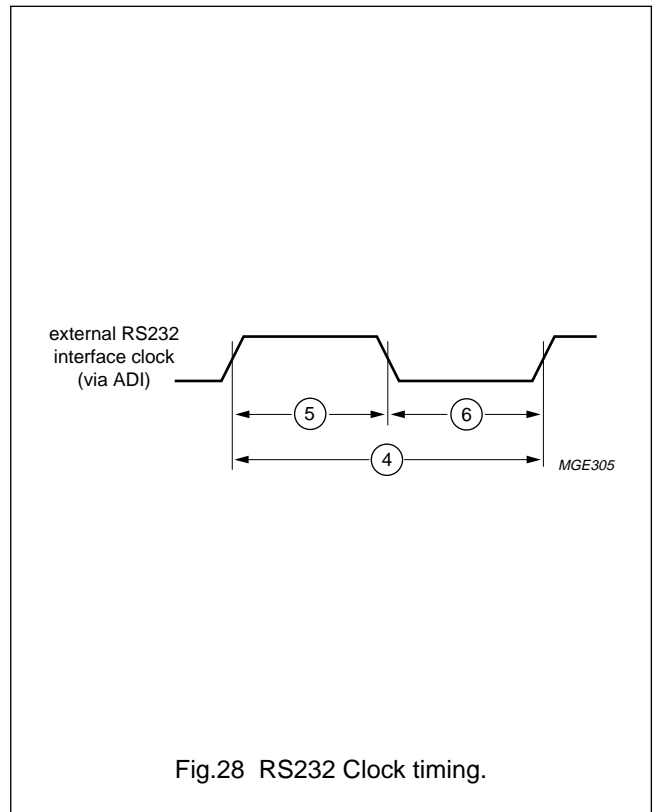
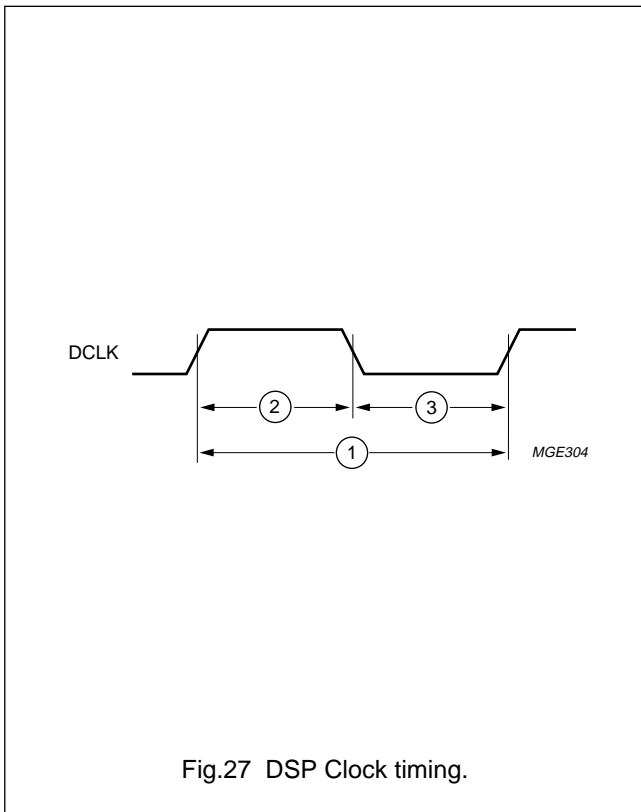
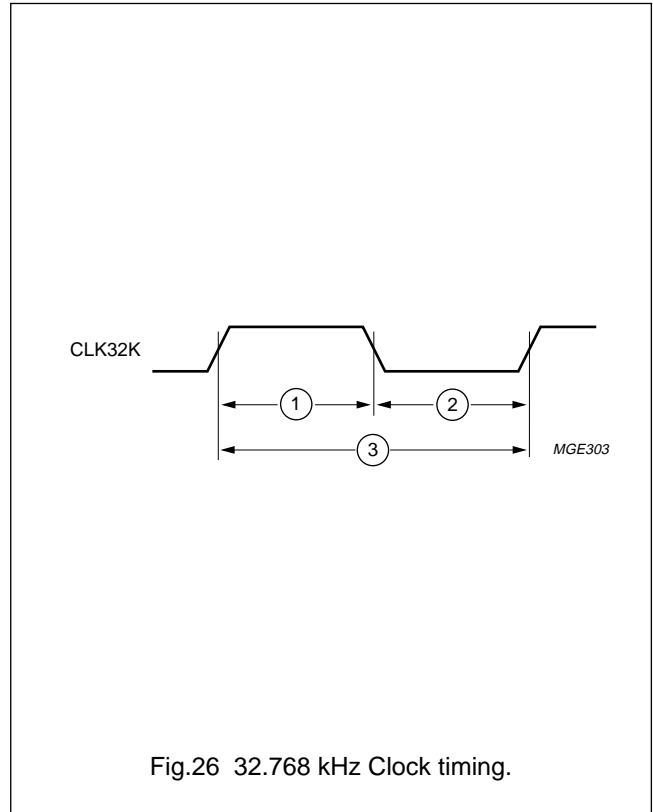
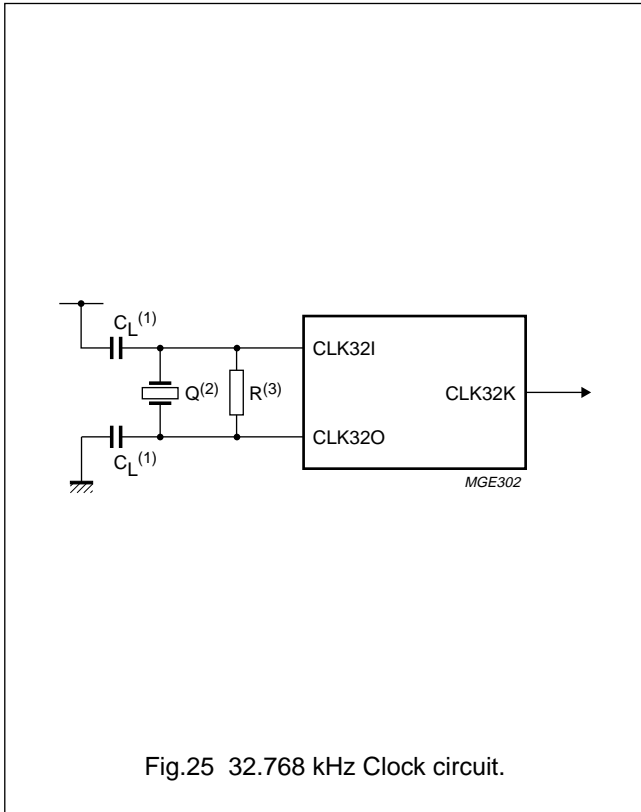

Fig.24 13 MHz Clock timing.

GSM signal processing IC

PCF5083



GSM signal processing IC

PCF5083

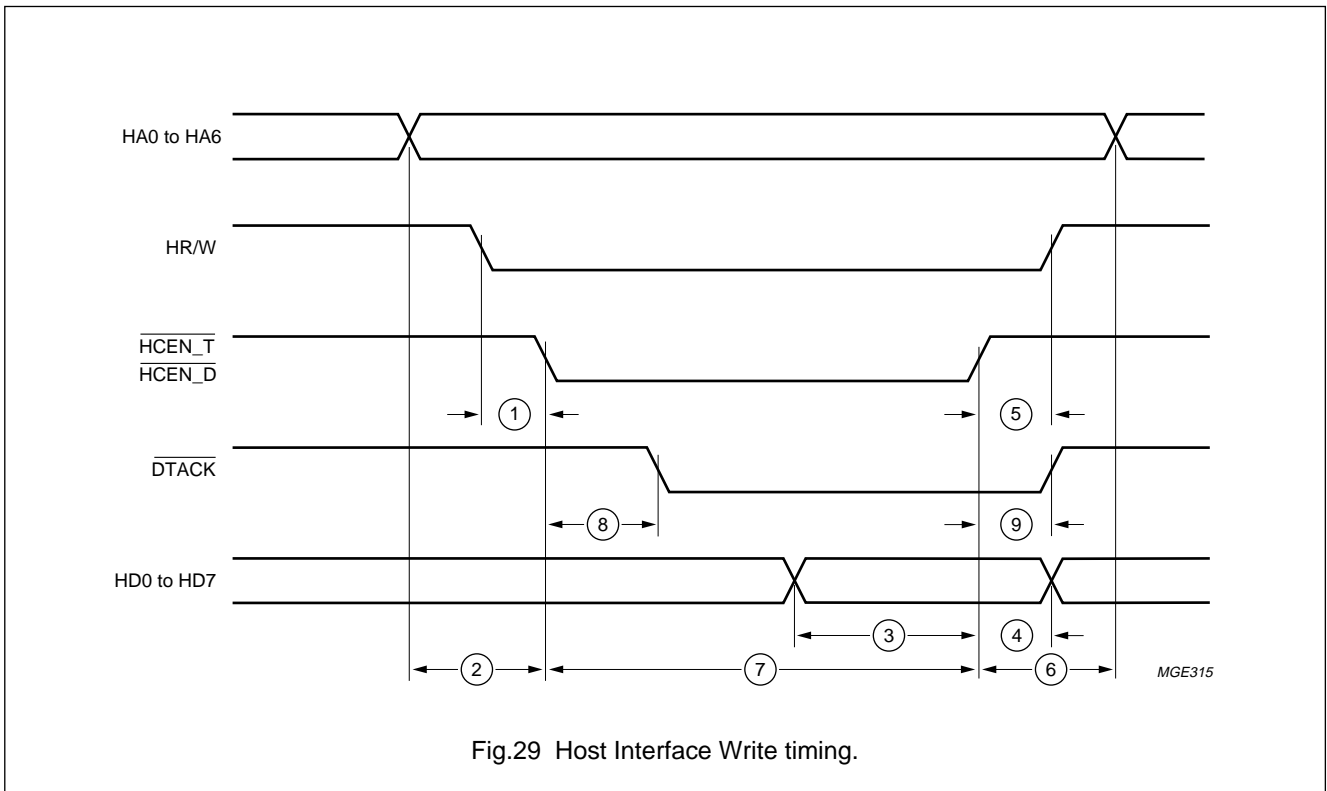

Fig.29 Host Interface Write timing.

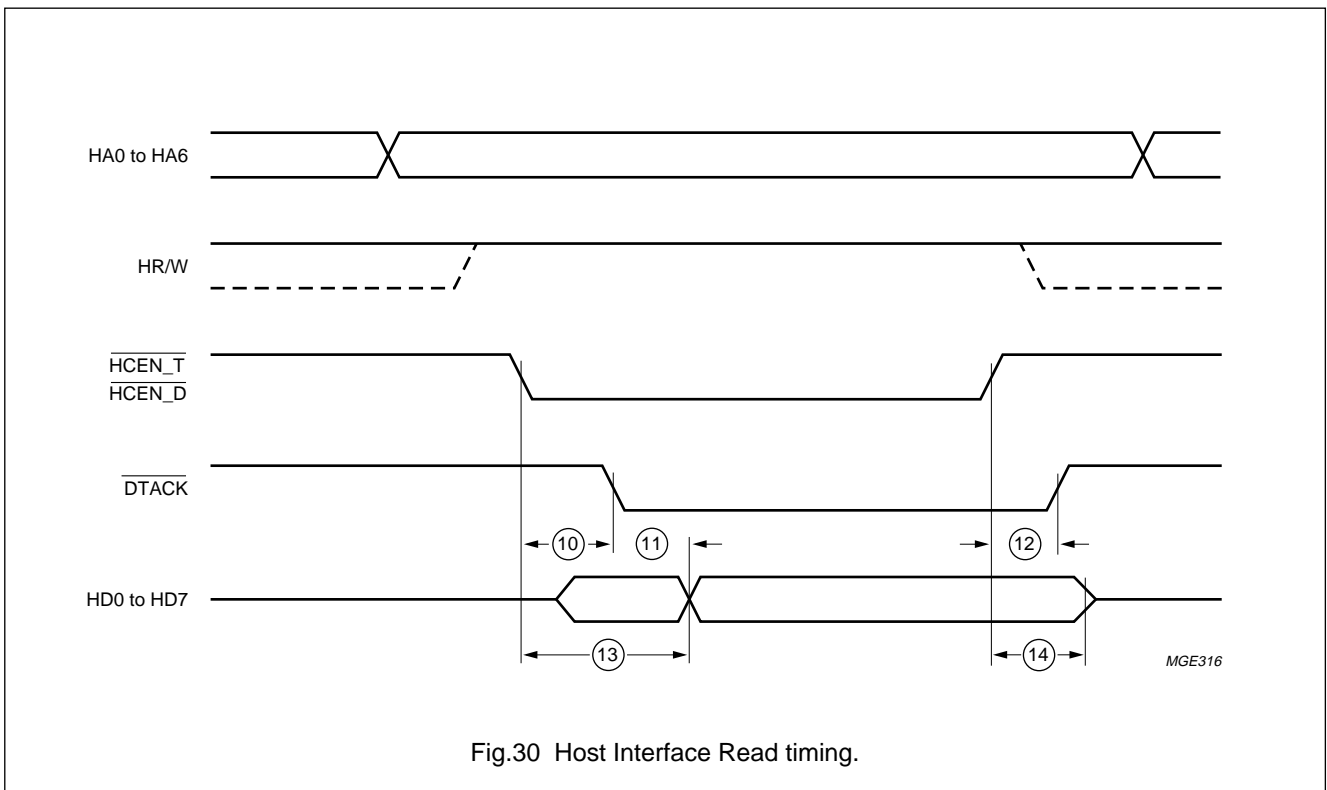
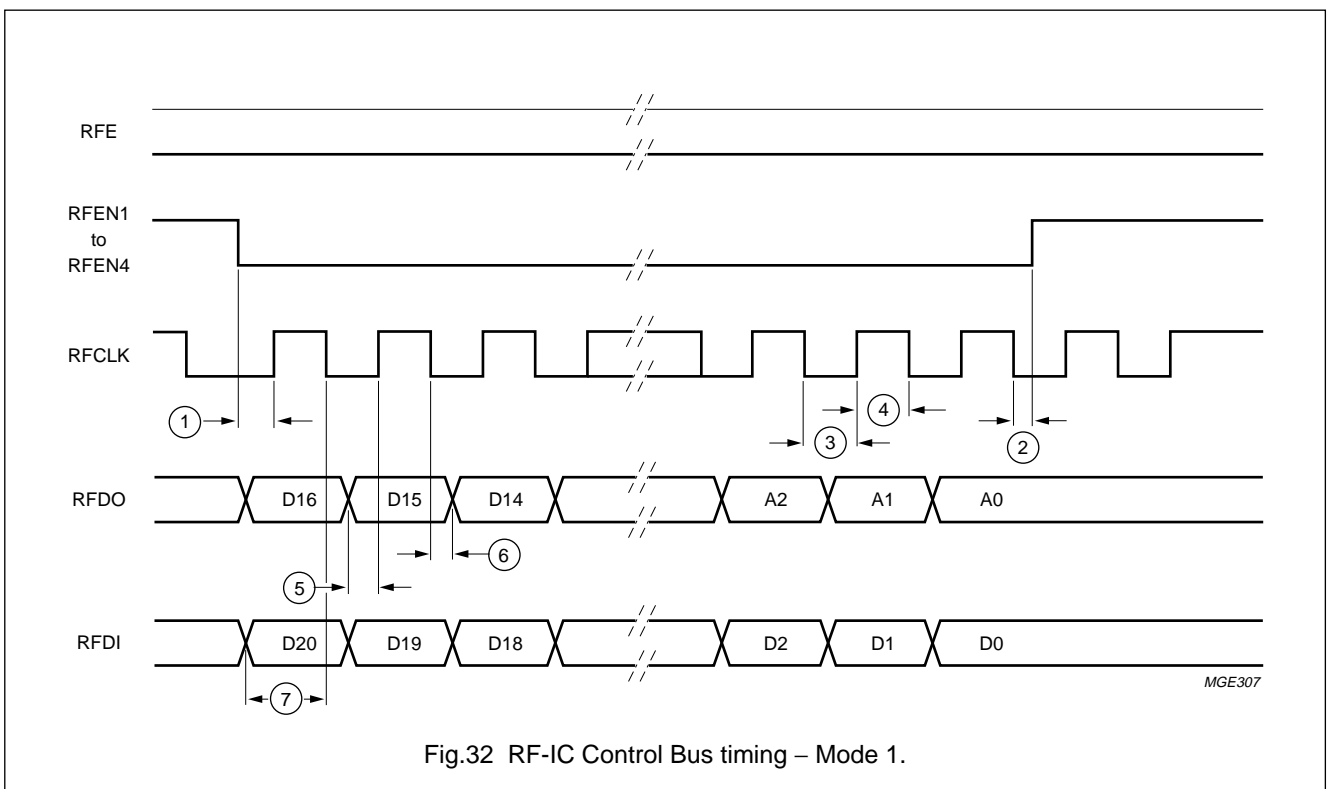
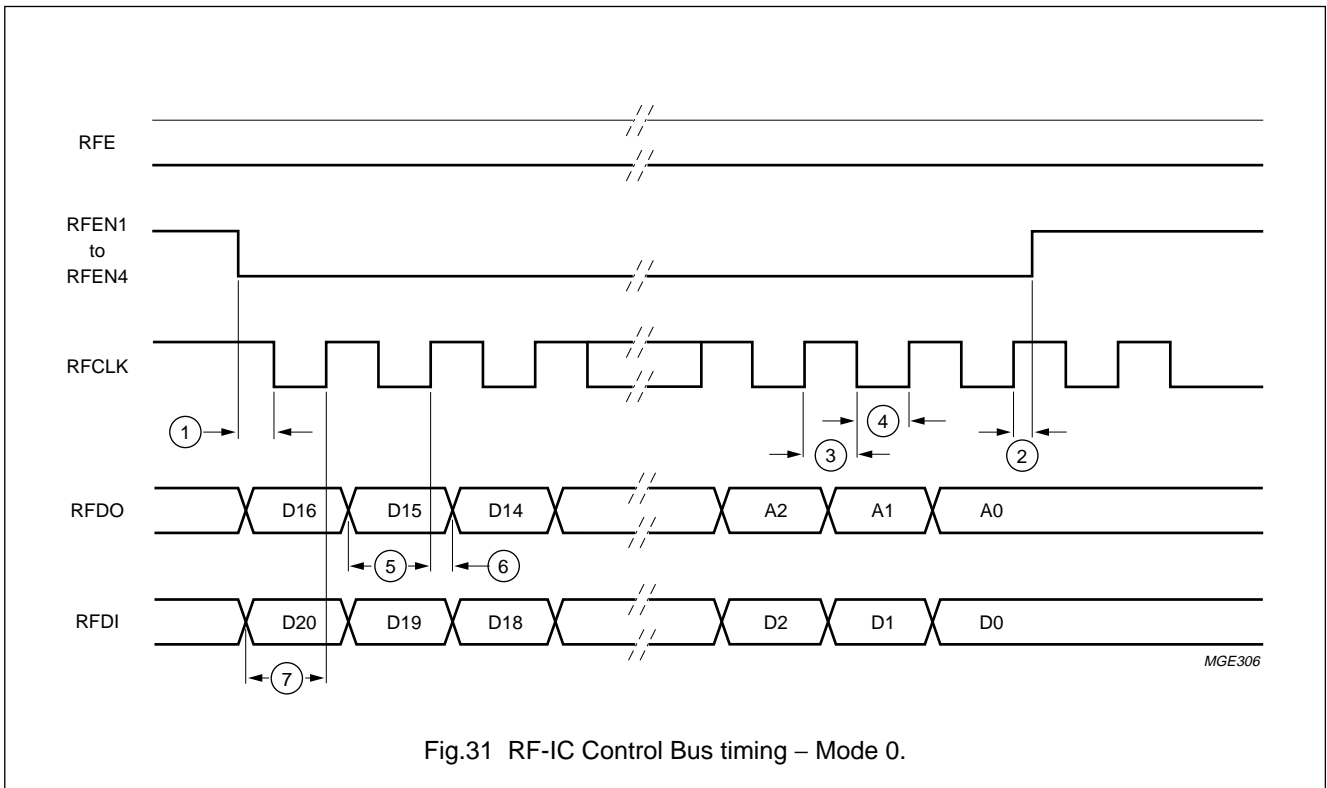

Fig.30 Host Interface Read timing.

GSM signal processing IC

PCF5083



GSM signal processing IC

PCF5083

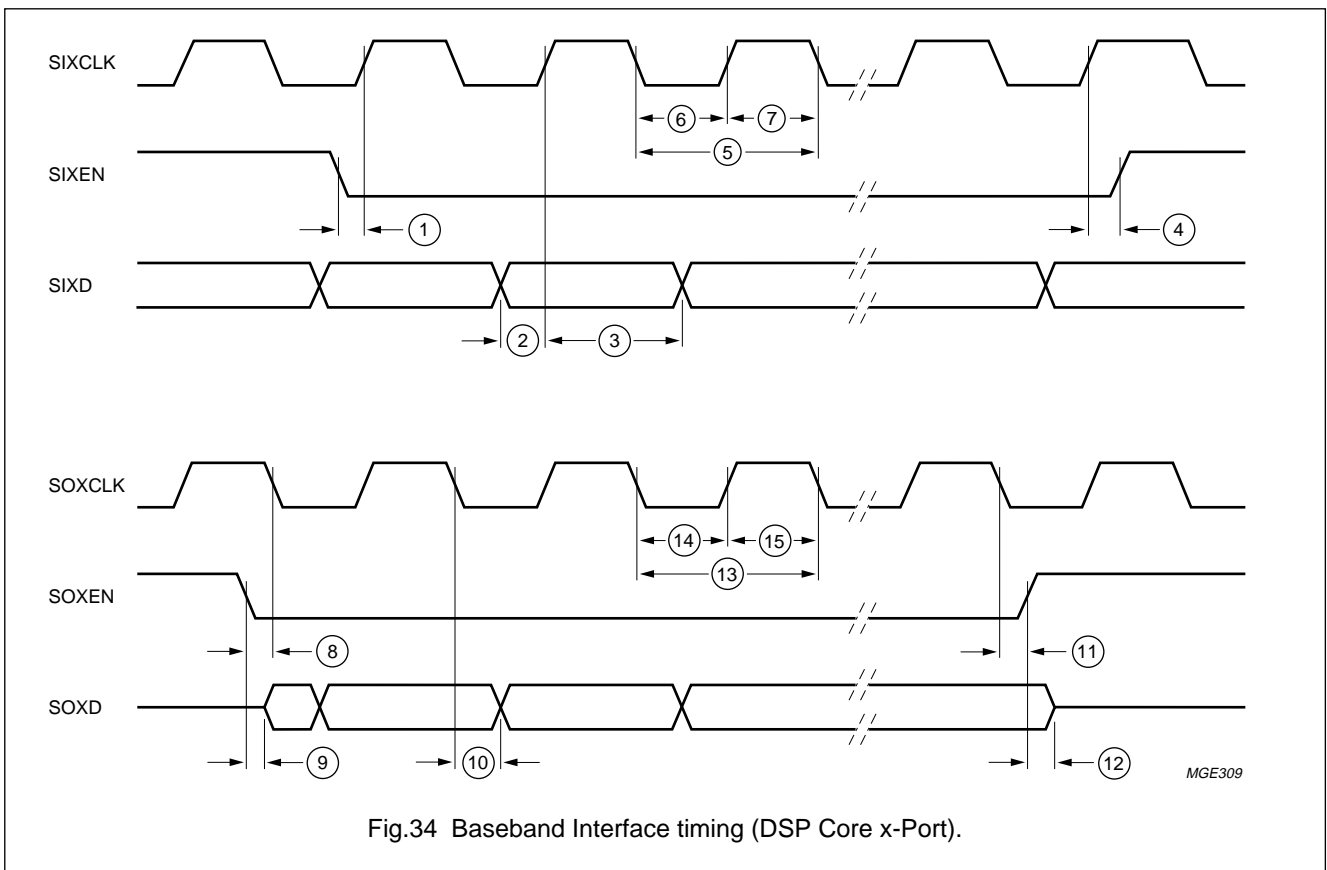
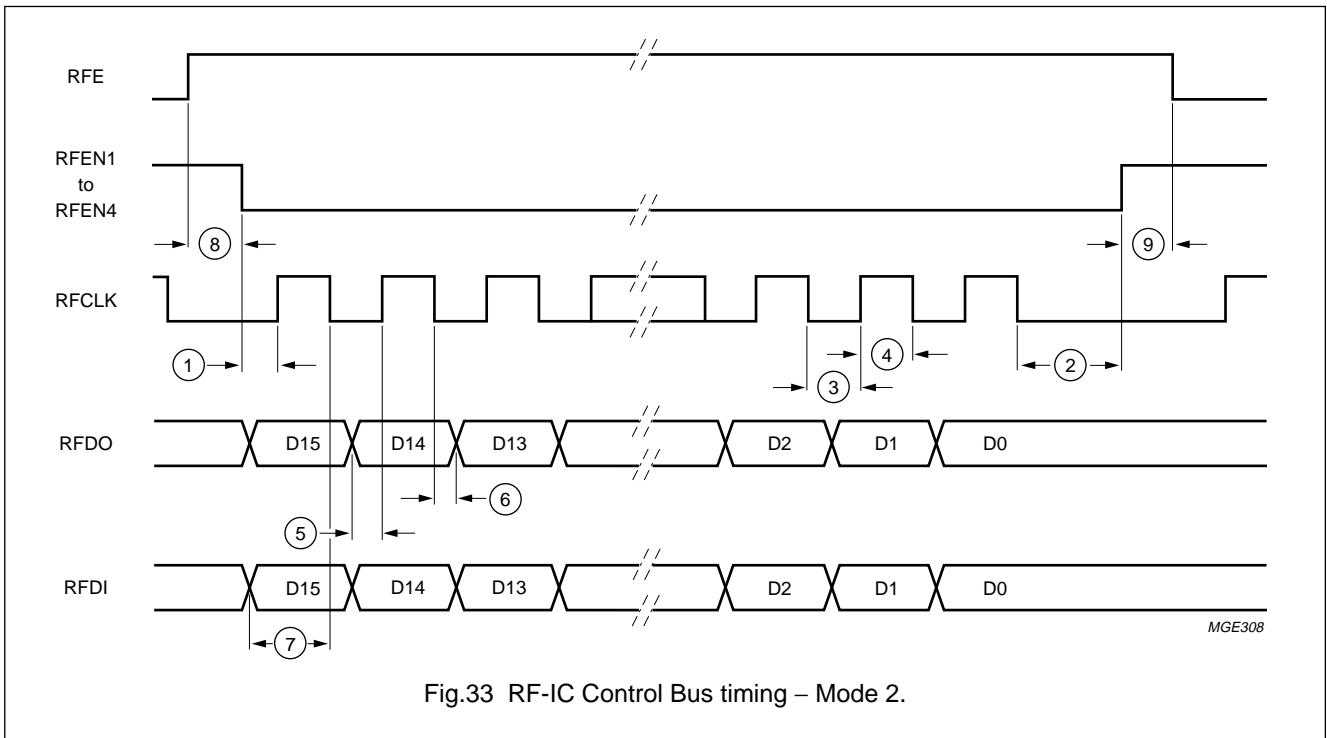

GSM signal processing IC

PCF5083

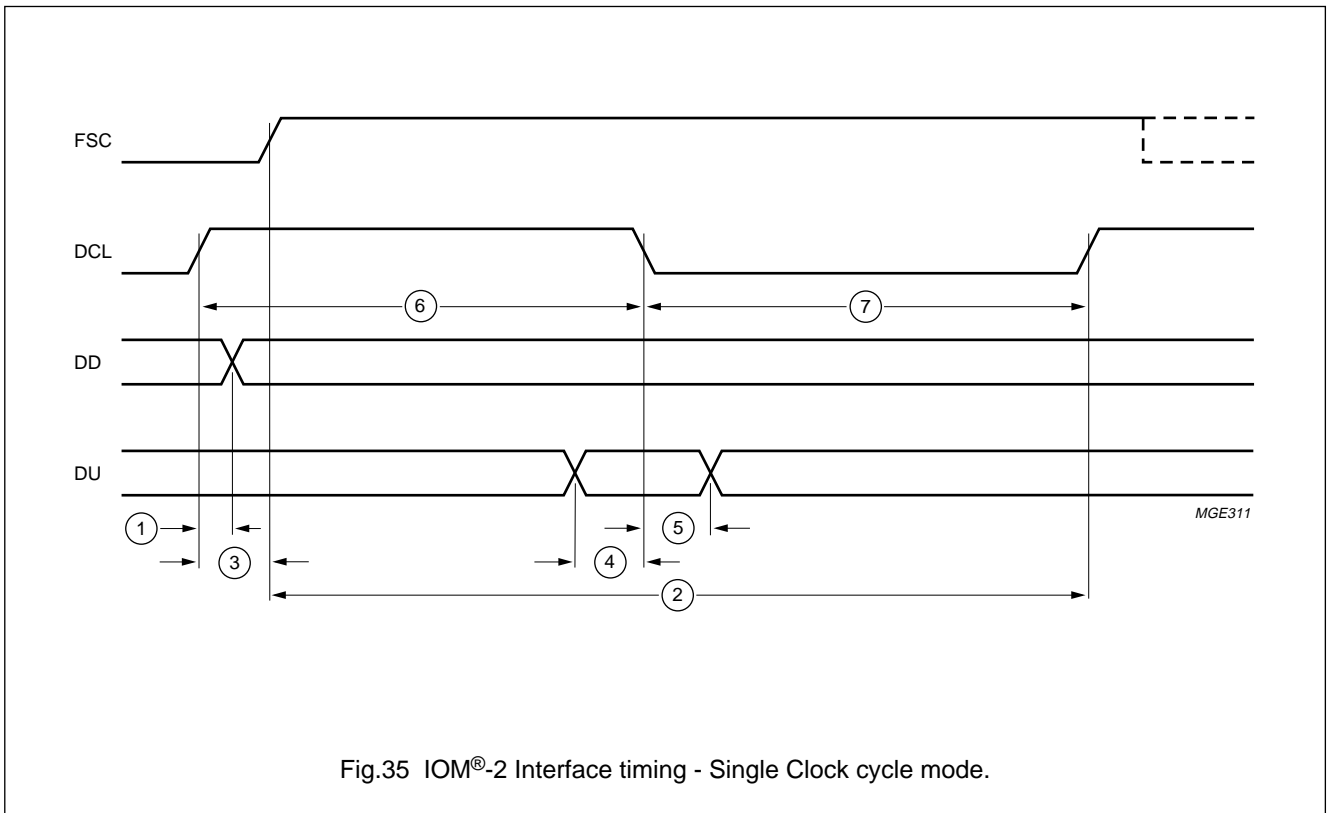

Fig.35 IOM<sup>®</sup>-2 Interface timing - Single Clock cycle mode.

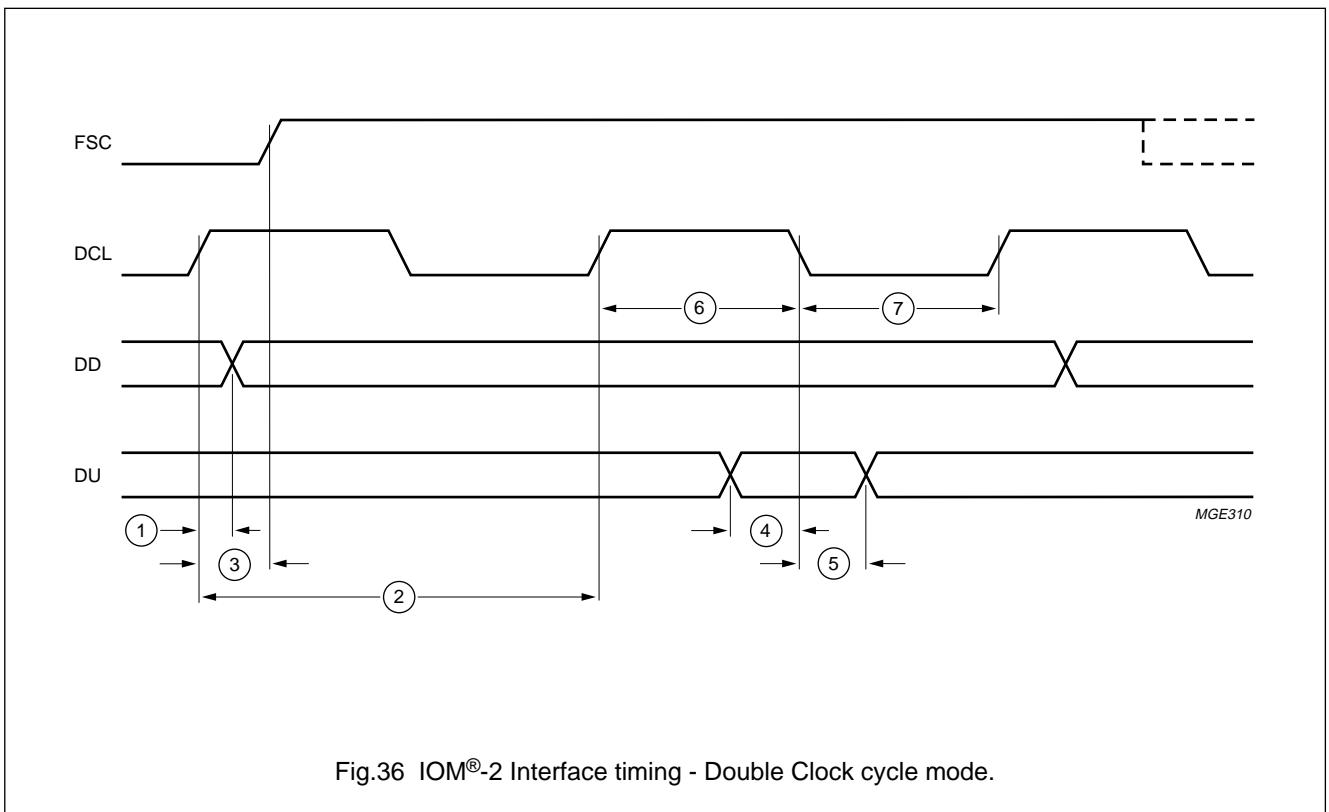
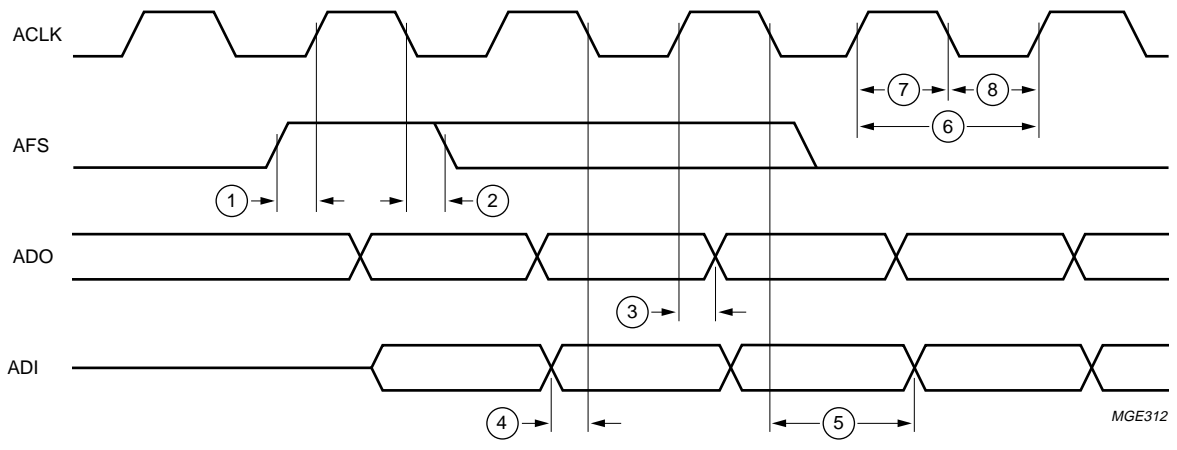

Fig.36 IOM<sup>®</sup>-2 Interface timing - Double Clock cycle mode.

GSM signal processing IC

PCF5083



MGE312

Fig.37 Audio Interface timing (non-transparent mode).

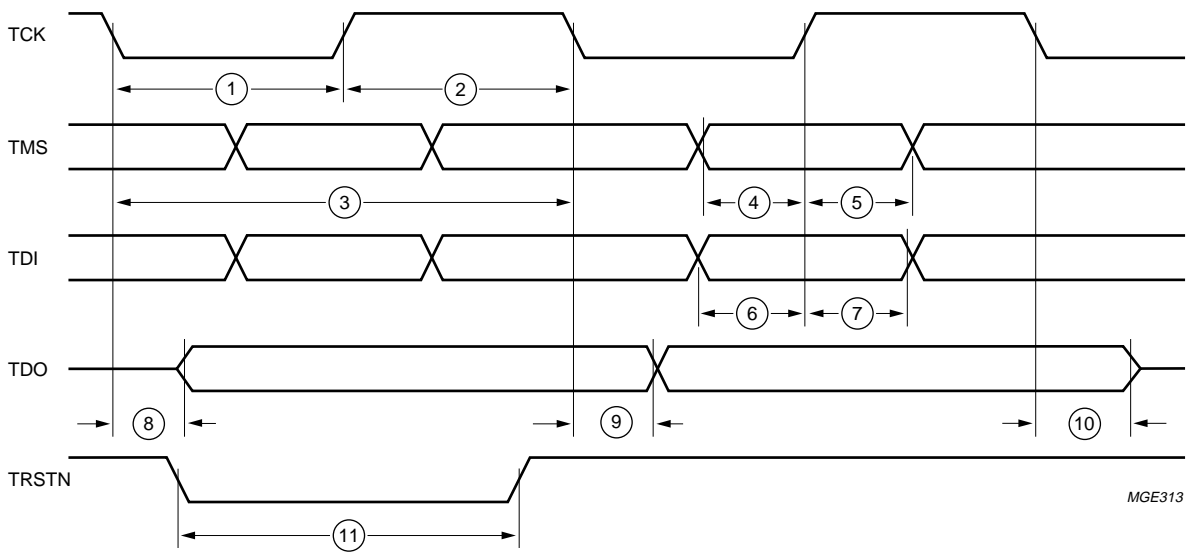

MGE313

Fig.38 JTAG port timing.



GSM signal processing IC

PCF5083

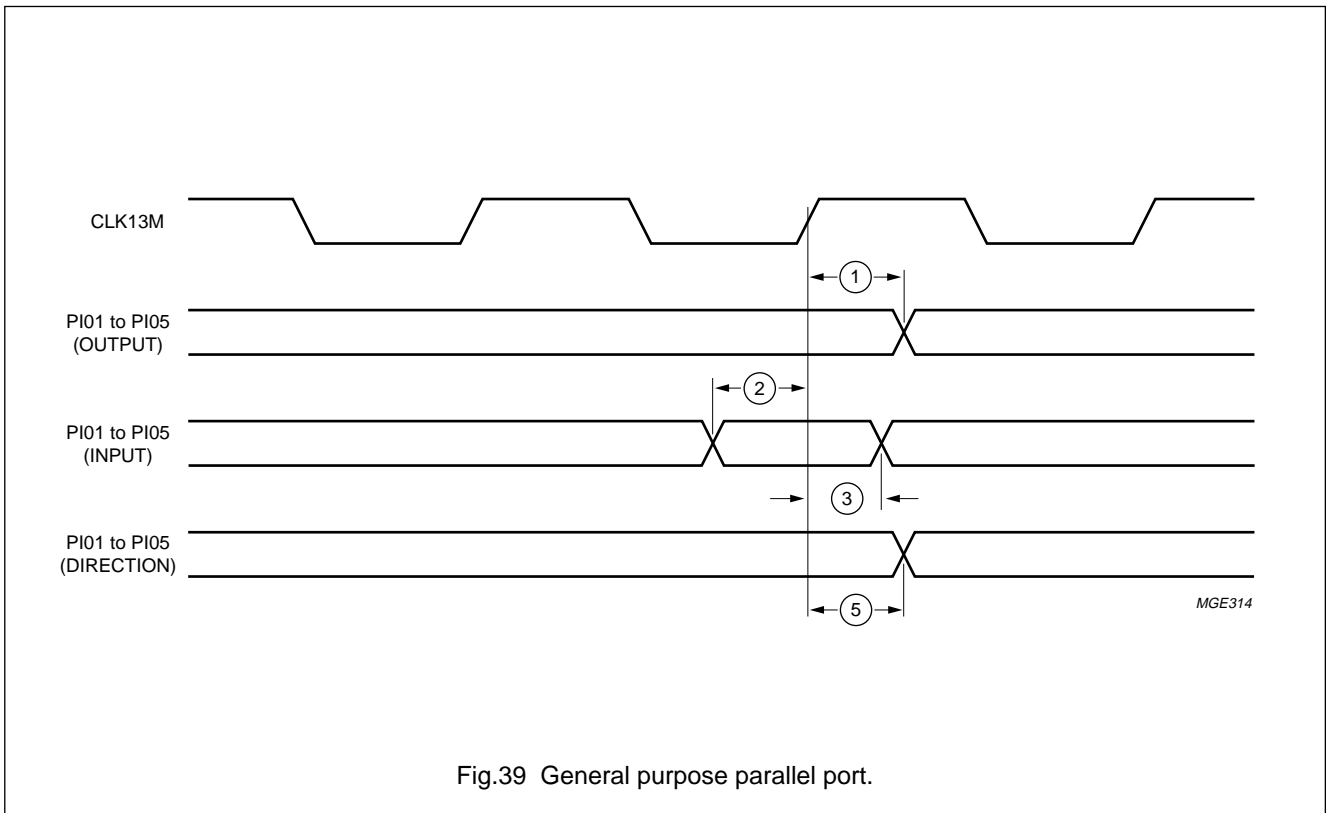

Fig.39 General purpose parallel port.

# GSM signal processing IC

# PCF5083

## 17 APPLICATION INFORMATION

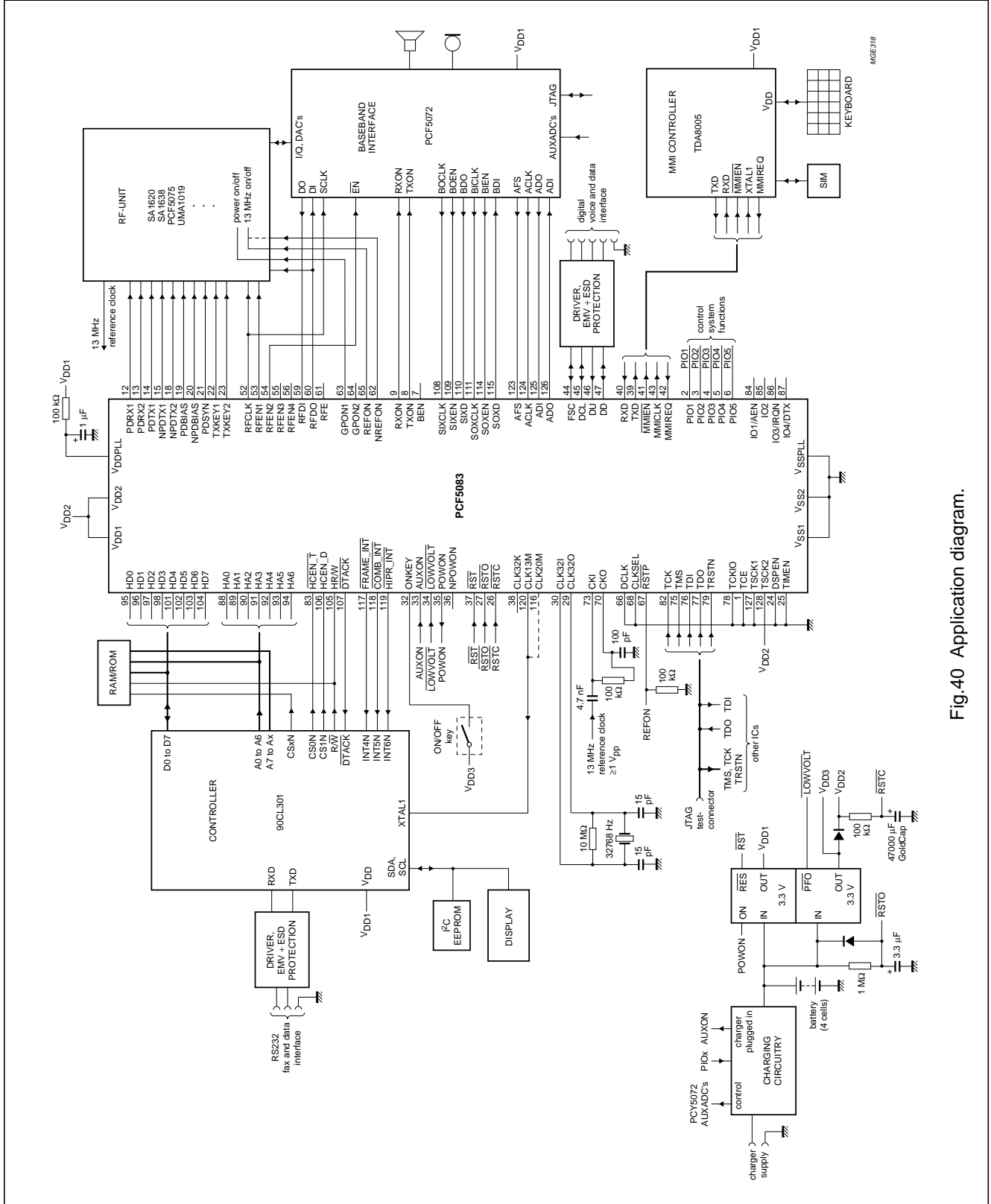

Fig.40 Application diagram.

GSM signal processing IC

PCF5083

18 PACKAGE OUTLINE

LQFP128: plastic low profile quad flat package; 128 leads; body 14 x 14 x 1.4 mm

SOT420-1

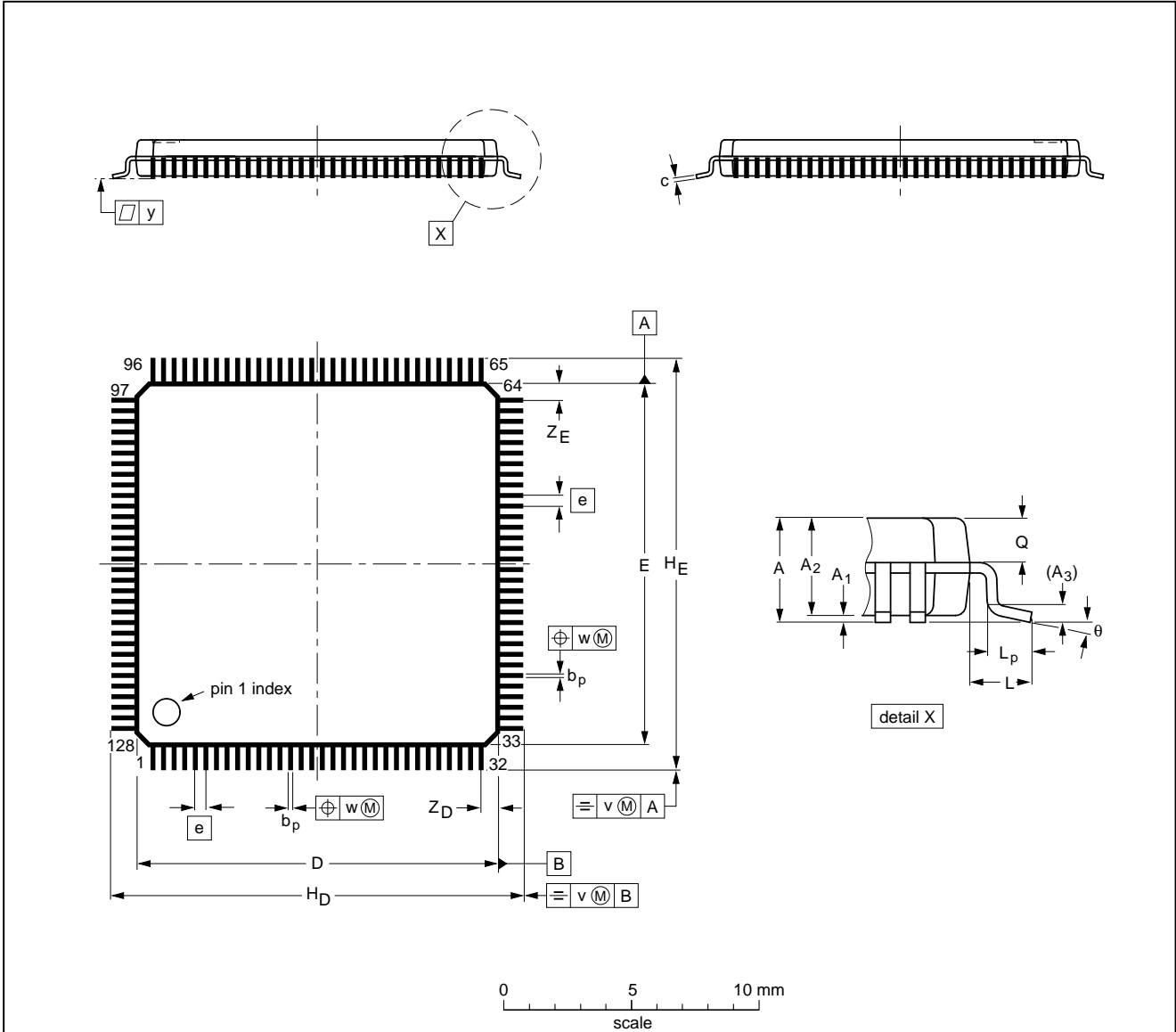

DIMENSIONS (mm are the original dimensions)

UNIT	A max.	A <sub>1</sub>	A <sub>2</sub>	A <sub>3</sub>	b <sub>p</sub>	c	D <sup>(1)</sup>	E <sup>(1)</sup>	e	H <sub>D</sub>	H <sub>E</sub>	L	L <sub>p</sub>	Q	v	w	y	Z <sub>D</sub> <sup>(1)</sup>	Z <sub>E</sub> <sup>(1)</sup>	θ
mm	1.6	0.15 0.05	1.45 1.35	0.25	0.23 0.13	0.20 0.09	14.1 13.9	14.1 13.9	0.4	16.15 15.85	16.15 15.85	1.0	0.75 0.45	0.70 0.58	0.2	0.08	0.1	0.95 0.65	0.95 0.65	7° 0°

Note

1. Plastic or metal protrusions of 0.25 mm maximum per side are not included.

OUTLINE VERSION	REFERENCES				EUROPEAN PROJECTION	ISSUE DATE
	IEC	JEDEC	EIAJ			
SOT420-1						96-02-07

---

## GSM signal processing IC

## PCF5083

---

### 19 SOLDERING

#### 19.1 Introduction

There is no soldering method that is ideal for all IC packages. Wave soldering is often preferred when through-hole and surface mounted components are mixed on one printed-circuit board. However, wave soldering is not always suitable for surface mounted ICs, or for printed-circuits with high population densities. In these situations reflow soldering is often used.

This text gives a very brief insight to a complex technology. A more in-depth account of soldering ICs can be found in our *"IC Package Databook"* (order code 9398 652 90011).

#### 19.2 Reflow soldering

Reflow soldering techniques are suitable for all LQFP packages.

Reflow soldering requires solder paste (a suspension of fine solder particles, flux and binding agent) to be applied to the printed-circuit board by screen printing, stencilling or pressure-syringe dispensing before package placement.

Several techniques exist for reflowing; for example, thermal conduction by heated belt. Dwell times vary between 50 and 300 seconds depending on heating method. Typical reflow temperatures range from 215 to 250 °C.

Preheating is necessary to dry the paste and evaporate the binding agent. Preheating duration: 45 minutes at 45 °C.

#### 19.3 Wave soldering

Wave soldering is **not** recommended for LQFP packages. This is because of the likelihood of solder bridging due to closely-spaced leads and the possibility of incomplete solder penetration in multi-lead devices.

If wave soldering cannot be avoided, the following conditions must be observed:

- **A double-wave (a turbulent wave with high upward pressure followed by a smooth laminar wave) soldering technique should be used.**
- **The footprint must be at an angle of 45° to the board direction and must incorporate solder thieves downstream and at the side corners.**

**Even with these conditions, do not consider wave soldering LQFP packages LQFP48 (SOT313-2), LQFP64 (SOT314-2) or LQFP80 (SOT315-1).**

During placement and before soldering, the package must be fixed with a droplet of adhesive. The adhesive can be applied by screen printing, pin transfer or syringe dispensing. The package can be soldered after the adhesive is cured.

Maximum permissible solder temperature is 260 °C, and maximum duration of package immersion in solder is 10 seconds, if cooled to less than 150 °C within 6 seconds. Typical dwell time is 4 seconds at 250 °C.

A mildly-activated flux will eliminate the need for removal of corrosive residues in most applications.

#### 19.4 Repairing soldered joints

Fix the component by first soldering two diagonally-opposite end leads. Use only a low voltage soldering iron (less than 24 V) applied to the flat part of the lead. Contact time must be limited to 10 seconds at up to 300 °C. When using a dedicated tool, all other leads can be soldered in one operation within 2 to 5 seconds between 270 and 320 °C.

## GSM signal processing IC

PCF5083

**20 DEFINITIONS**

<b>Data sheet status</b>	
Objective specification	This data sheet contains target or goal specifications for product development.
Preliminary specification	This data sheet contains preliminary data; supplementary data may be published later.
Product specification	This data sheet contains final product specifications.
<b>Limiting values</b>	
Limiting values given are in accordance with the Absolute Maximum Rating System (IEC 134). Stress above one or more of the limiting values may cause permanent damage to the device. These are stress ratings only and operation of the device at these or at any other conditions above those given in the Characteristics sections of the specification is not implied. Exposure to limiting values for extended periods may affect device reliability.	
<b>Application information</b>	
Where application information is given, it is advisory and does not form part of the specification.	

**21 LIFE SUPPORT APPLICATIONS**

These products are not designed for use in life support appliances, devices, or systems where malfunction of these products can reasonably be expected to result in personal injury. Philips customers using or selling these products for use in such applications do so at their own risk and agree to fully indemnify Philips for any damages resulting from such improper use or sale.

GSM signal processing IC

PCF5083

---

**NOTES**

GSM signal processing IC

PCF5083

---

**NOTES**

# Philips Semiconductors – a worldwide company

**Argentina:** see South America

**Australia:** 34 Waterloo Road, NORTH RYDE, NSW 2113,  
Tel. +61 2 9805 4455, Fax. +61 2 9805 4466

**Austria:** Computerstr. 6, A-1101 WIEN, P.O. Box 213,  
Tel. +43 1 60 101, Fax. +43 1 60 101 1210

**Belarus:** Hotel Minsk Business Center, Bld. 3, r. 1211, Volodarski Str. 6,  
220050 MINSK, Tel. +375 172 200 733, Fax. +375 172 200 773

**Belgium:** see The Netherlands

**Brazil:** see South America

**Bulgaria:** Philips Bulgaria Ltd., Energoproject, 15th floor,  
51 James Bourchier Blvd., 1407 SOFIA,  
Tel. +359 2 689 211, Fax. +359 2 689 102

**Canada:** PHILIPS SEMICONDUCTORS/COMPONENTS,  
Tel. +1 800 234 7381

**China/Hong Kong:** 501 Hong Kong Industrial Technology Centre,  
72 Tat Chee Avenue, Kowloon Tong, HONG KONG,  
Tel. +852 2319 7888, Fax. +852 2319 7700

**Colombia:** see South America

**Czech Republic:** see Austria

**Denmark:** Prags Boulevard 80, PB 1919, DK-2300 COPENHAGEN S,  
Tel. +45 32 88 2636, Fax. +45 31 57 1949

**Finland:** Sinikalliontie 3, FIN-02630 ESPOO,  
Tel. +358 9 615800, Fax. +358 9 61580/xxx

**France:** 4 Rue du Port-aux-Vins, BP317, 92156 SURESNES Cedex,  
Tel. +33 1 40 99 6161, Fax. +33 1 40 99 6427

**Germany:** Hammerbrookstraße 69, D-20097 HAMBURG,  
Tel. +49 40 23 53 60, Fax. +49 40 23 536 300

**Greece:** No. 15, 25th March Street, GR 17778 TAVROS/ATHENS,  
Tel. +30 1 4894 339/239, Fax. +30 1 4814 240

**Hungary:** see Austria

**India:** Philips INDIA Ltd, Shivsagar Estate, A Block, Dr. Annie Besant Rd.  
Worli, MUMBAI 400 018, Tel. +91 22 4938 541, Fax. +91 22 4938 722

**Indonesia:** see Singapore

**Ireland:** Newstead, Clonskeagh, DUBLIN 14,  
Tel. +353 1 7640 000, Fax. +353 1 7640 200

**Israel:** RAPAC Electronics, 7 Kehilat Saloniki St, TEL AVIV 61180,  
Tel. +972 3 645 0444, Fax. +972 3 649 1007

**Italy:** PHILIPS SEMICONDUCTORS, Piazza IV Novembre 3,  
20124 MILANO, Tel. +39 2 6752 2531, Fax. +39 2 6752 2557

**Japan:** Philips Bldg 13-37, Kohnan 2-chome, Minato-ku, TOKYO 108,  
Tel. +81 3 3740 5130, Fax. +81 3 3740 5077

**Korea:** Philips House, 260-199 Itaewon-dong, Yongsan-ku, SEOUL,  
Tel. +82 2 709 1412, Fax. +82 2 709 1415

**Malaysia:** No. 76 Jalan Universiti, 46200 PETALING JAYA, SELANGOR,  
Tel. +60 3 750 5214, Fax. +60 3 757 4880

**Mexico:** 5900 Gateway East, Suite 200, EL PASO, TEXAS 79905,  
Tel. +9-5 800 234 7381

**Middle East:** see Italy

**Netherlands:** Postbus 90050, 5600 PB EINDHOVEN, Bldg. VB,  
Tel. +31 40 27 82785, Fax. +31 40 27 88399

**New Zealand:** 2 Wagener Place, C.P.O. Box 1041, AUCKLAND,  
Tel. +64 9 849 4160, Fax. +64 9 849 7811

**Norway:** Box 1, Manglerud 0612, OSLO,  
Tel. +47 22 74 8000, Fax. +47 22 74 8341

**Philippines:** Philips Semiconductors Philippines Inc.,  
106 Valero St. Salcedo Village, P.O. Box 2108 MCC, MAKATI,  
Metro MANILA, Tel. +63 2 816 6380, Fax. +63 2 817 3474

**Poland:** Ul. Lukiska 10, PL 04-123 WARSZAWA,  
Tel. +48 22 612 2831, Fax. +48 22 612 2327

**Portugal:** see Spain

**Romania:** see Italy

**Russia:** Philips Russia, Ul. Usatcheva 35A, 119048 MOSCOW,  
Tel. +7 095 247 9145, Fax. +7 095 247 9144

**Singapore:** Lorong 1, Toa Payoh, SINGAPORE 1231,  
Tel. +65 350 2538, Fax. +65 251 6500

**Slovakia:** see Austria

**Slovenia:** see Italy

**South Africa:** S.A. PHILIPS Pty Ltd., 195-215 Main Road Martindale,  
2092 JOHANNESBURG, P.O. Box 7430 Johannesburg 2000,  
Tel. +27 11 470 5911, Fax. +27 11 470 5494

**South America:** Rua do Rocio 220, 5th floor, Suite 51,  
04552-903 São Paulo, SÃO PAULO - SP, Brazil,  
Tel. +55 11 821 2333, Fax. +55 11 829 1849

**Spain:** Balmes 22, 08007 BARCELONA,  
Tel. +34 3 301 6312, Fax. +34 3 301 4107

**Sweden:** Kottbygatan 7, Akalla, S-16485 STOCKHOLM,  
Tel. +46 8 632 2000, Fax. +46 8 632 2745

**Switzerland:** Allmendstrasse 140, CH-8027 ZÜRICH,  
Tel. +41 1 488 2686, Fax. +41 1 481 7730

**Taiwan:** PHILIPS TAIWAN Ltd., 23-30F, 66,  
Chung Hsiao West Road, Sec. 1, P.O. Box 22978,  
TAIPEI 100, Tel. +886 2 382 4443, Fax. +886 2 382 4444

**Thailand:** PHILIPS ELECTRONICS (THAILAND) Ltd.,  
209/2 Sanpavuth-Bangna Road Prakanong, BANGKOK 10260,  
Tel. +66 2 745 4090, Fax. +66 2 398 0793

**Turkey:** Talatpasa Cad. No. 5, 80640 GÜLTEPE/ISTANBUL,  
Tel. +90 212 279 2770, Fax. +90 212 282 6707

**Ukraine:** PHILIPS UKRAINE, 4 Patrice Lumumba str., Building B, Floor 7,  
252042 KIEV, Tel. +380 44 264 2776, Fax. +380 44 268 0461

**United Kingdom:** Philips Semiconductors Ltd., 276 Bath Road, Hayes,  
MIDDLESEX UB3 5BX, Tel. +44 181 730 5000, Fax. +44 181 754 8421

**United States:** 811 East Arques Avenue, SUNNYVALE, CA 94088-3409,  
Tel. +1 800 234 7381

**Uruguay:** see South America

**Vietnam:** see Singapore

**Yugoslavia:** PHILIPS, Trg N. Pasica 5/v, 11000 BEOGRAD,  
Tel. +381 11 625 344, Fax. +381 11 635 777

**For all other countries apply to:** Philips Semiconductors, Marketing & Sales Communications,  
Building BE-p, P.O. Box 218, 5600 MD EINDHOVEN, The Netherlands, Fax. +31 40 27 24825

**Internet:** <http://www.semiconductors.philips.com>

© Philips Electronics N.V. 1996

SCA52

All rights are reserved. Reproduction in whole or in part is prohibited without the prior written consent of the copyright owner.

The information presented in this document does not form part of any quotation or contract, is believed to be accurate and reliable and may be changed without notice. No liability will be accepted by the publisher for any consequence of its use. Publication thereof does not convey nor imply any license under patent- or other industrial or intellectual property rights.

Printed in The Netherlands

647021/05/01/pp136

Date of release: 1996 Oct 29

Document order number: 9397 750 01454

*Let's make things better.*

**Philips**  
Semiconductors



**PHILIPS**