

Protection in Portable Electronics Applications.

### FEATURES

- 150 Watts peak pulse power ( $t_p=8/20 \mu s$ )
- Transient protection for data lines to IEC61000-4-2(ESD) 15kV(Air), 8kV(Contact).
- Protects five I/O lines.
- Low clamping voltage.
- Low operating and leakage current.
- Small package for use in portable electronics.
- Suffix U : Qualified to AEC-Q101.  
ex) PG05GXTE6-RTK/HU

### APPLICATIONS

- Cell phone handsets and accessories.
- Cordless phones.
- Personal digital assistants (PDA's)
- Notebooks, desktops, & servers.
- Portable instrumentation.
- Set-Top Box, DVD Player.
- Digital Camera.

### MAXIMUM RATING (Ta=25 °C)

CHARACTERISTIC	SYMBOL	RATING	UNIT
Peak Pulse Power ( $t_p=8/20 \mu s$ )	$P_{PK}$	150	W
Peak Pulse Current ( $t_p=8/20 \mu s$ )	$I_{PP}$	10	A
Operating Temperature	$T_j$	-55 150	
Storage Temperature	$T_{stg}$	-55 150	

### ELECTRICAL CHARACTERISTICS (Ta=25 °C)

CHARACTERISTIC	SYMBOL	TEST CONDITION	MIN.	TYP.	MAX.	UNIT
Reverse Stand-Off Voltage	$V_{RWM}$	-	-	-	5	V
Reverse Breakdown Voltage	$V_{BR}$	$I_t=1mA$	6.3	-	-	V
Reverse Leakage Current	$I_R$	$V_{RWM}=5V$	-	-	1	$\mu A$
Clamping Voltage	$V_C$	$I_{PP}=10A, t_p=8/20 \mu s$	-	-	14.5	V
Junction Capacitance	$C_j$	$V_R=0V, f=1MHz$ Between I/O Pins and GND	-	-	100	pF

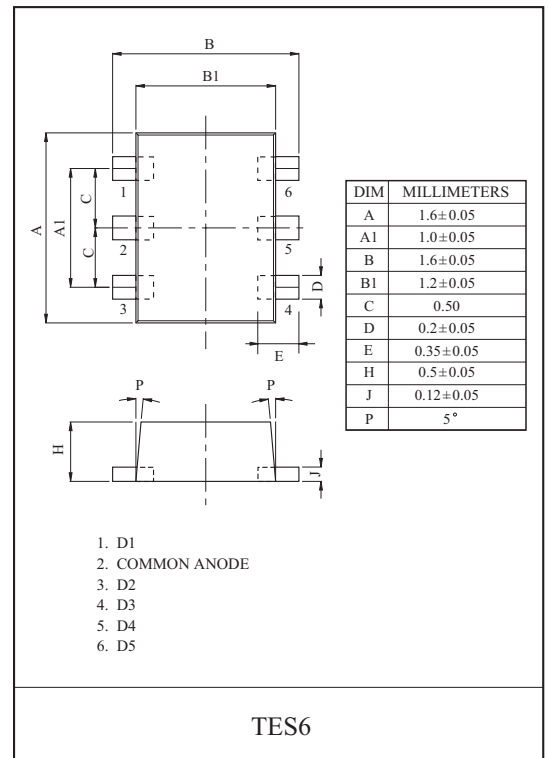

### Marking

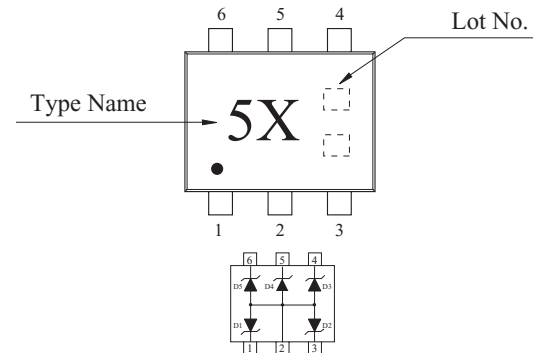

# PG05GXTE6

NON-REPETITIVE PEAK PULSE  
POWER VS. PULSE TIME

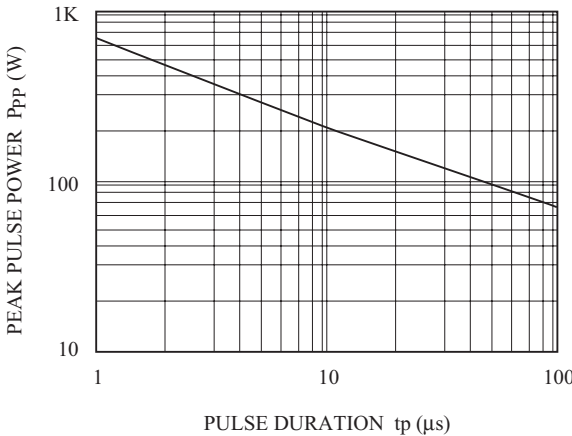

POWER DERATION CURVE

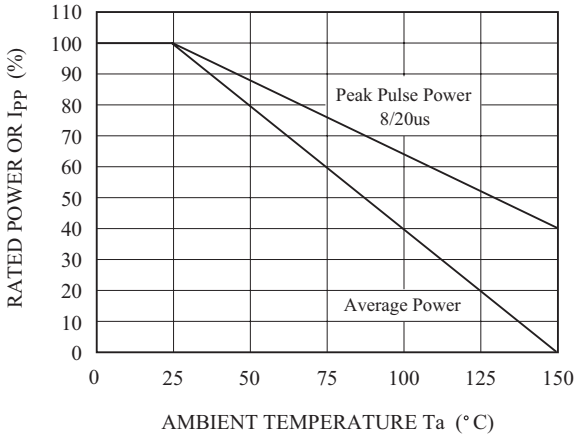

PULSE WAVEFORM

