

Protection in Portable Electronics Applications.

FEATURES

- 150 Watts peak pulse power ($t_p=8/20\mu s$)
- Transient protection for data lines to IEC 61000-4-2(ESD) 15kV(Air), 8kV(Contact).
- Protects five I/O lines.
- Low clamping voltage.
- Low operating and leakage current.
- Small package for use in portable electronics.

APPLICATIONS

- Cell phone handsets and accessories.
- Cordless phones.
- Personal digital assistants (PDA's)
- Notebooks, desktops, & servers.
- Portable instrumentation.
- Set-Top Box, DVD Player.
- Digital Camera.

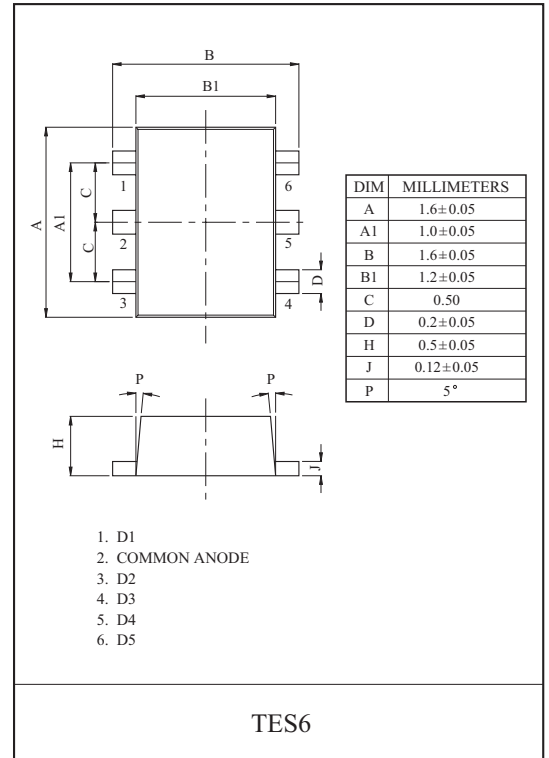

MAXIMUM RATING (Ta=25 °C)

CHARACTERISTIC	SYMBOL	RATING	UNIT
Peak Pulse Power ($t_p=8/20\mu s$)	P_{PK}	150	W
Peak Pulse Current ($t_p=8/20\mu s$)	I_{PP}	6	A
Operating Temperature	T_j	-55 ~ 150	°C
Storage Temperature	T_{stg}	-55 ~ 150	°C

Marking

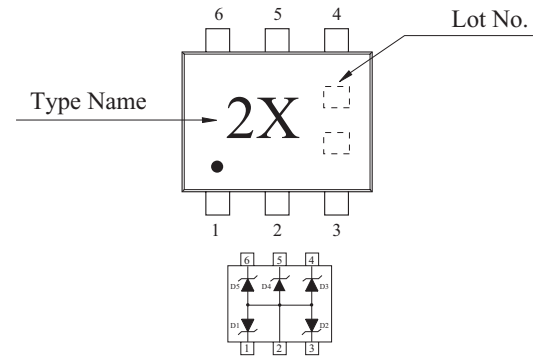

ELECTRICAL CHARACTERISTICS (Ta=25 °C)

CHARACTERISTIC	SYMBOL	TEST CONDITION	MIN.	TYP.	MAX.	UNIT
Reverse Stand-Off Voltage	V_{RWM}	-	-	-	12	V
Reverse Breakdown Voltage	V_{BR}	$I_t=1mA$	13.3	-	-	V
Reverse Leakage Current	I_R	$V_{RWM}=5V$	-	-	0.5	μA
Clamping Voltage	V_C	$I_{PP}=6A, t_p=8/20\mu s$	-	-	25	V
Junction Capacitance	C_J	$V_R=0V, f=1MHz$ Between I/O Pins and GND	-	-	60	pF

PG12FXTE6

NON-REPETITIVE PEAK PULSE
POWER VS. PULSE TIME

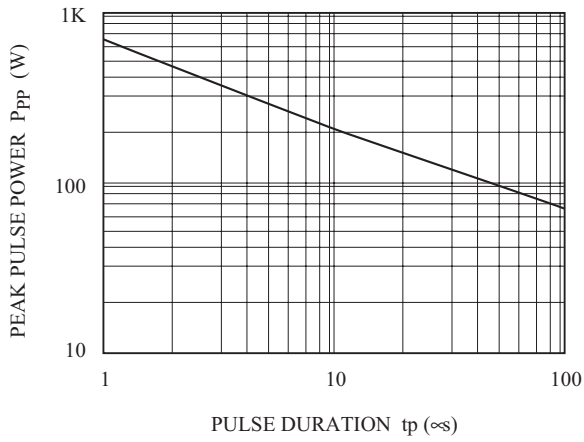

POWER DERATION CURVE

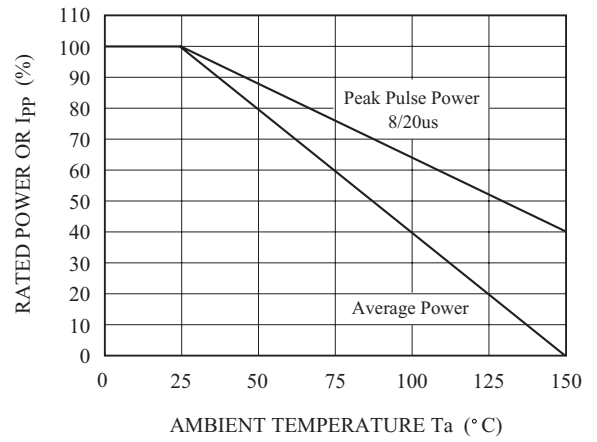

PULSE WAVEFORM

