

# PH5504A2NA1

R08DS0067EJ0100

Rev.1.00

Nov 05, 2012

Ambient Light Sensor

## DESCRIPTION

The PH5504A2NA1 is an ambient light sensor with a photo diode and current amplifier. This product has spectral characteristics close to human eye sensitivity and outputs light current proportional to the ambient brightness.

The PH5504A2NA1 can be used to improve the performance and reduce the power consumption of digital equipment such as FPD-TV sets and mobile phones, by enabling automatic brightness control and automatic switching on and off of lighting systems.

## FEATURES

- Small and thin SON package                      2.55 x 1.56 x 0.55 mm
- Spectral characteristics close to human eye sensitivity  
Peak sensitivity wavelength                      530 nm TYP.
- The impact of infrared light can be reduced by incorporating infrared light correction circuits.
- Output characteristics proportional to illuminance
- Output light current                                      55  $\mu$ A TYP. @ 100 lx (Fluorescent light)
- Reduced variation of output current among light sources
- Low voltage operation                                   $V_{CC} = 1.8$  to 5.5 V
- Pb-free

## APPLICATIONS

- FPD TV sets, displays
- Mobile phones, smartphones
- Notebook PCs, tablet PCs
- DSCs, DVCs
- FA equipment
- Lighting systems, etc.

Not recommended for new design

## PACKAGE DIMENSIONS (UNIT: mm)

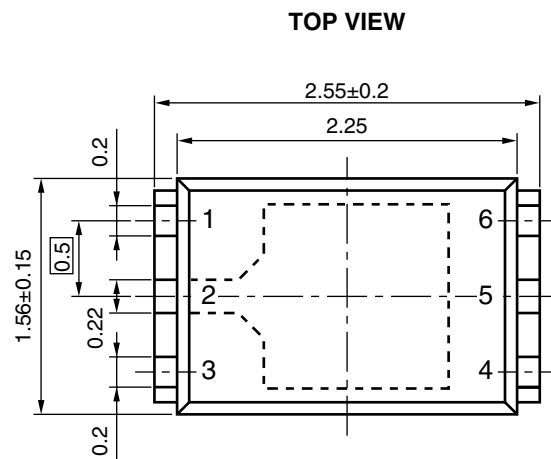

**Remark** Pin 1 is distinguishable by the shape of the lead frame.

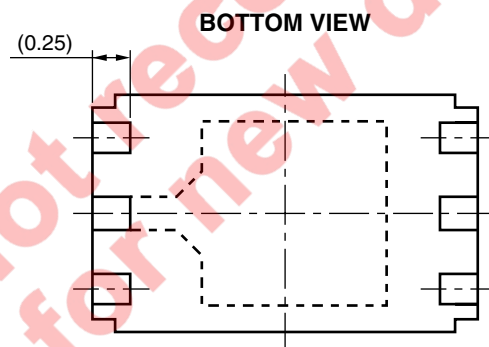

**Remark** ( ) indicates nominal dimensions.

Pin No.	Terminal
1	OUT
2	GND
3	V <sub>CC</sub>
4	NC
5	NC
6	NC

**Remark**

1. Connect all the NC terminals to GND or V<sub>CC</sub>.
2. The bypass capacitor between V<sub>CC</sub> and GND is to be mounted within 20 mm of the package body.

**BLOCK DIAGRAM**

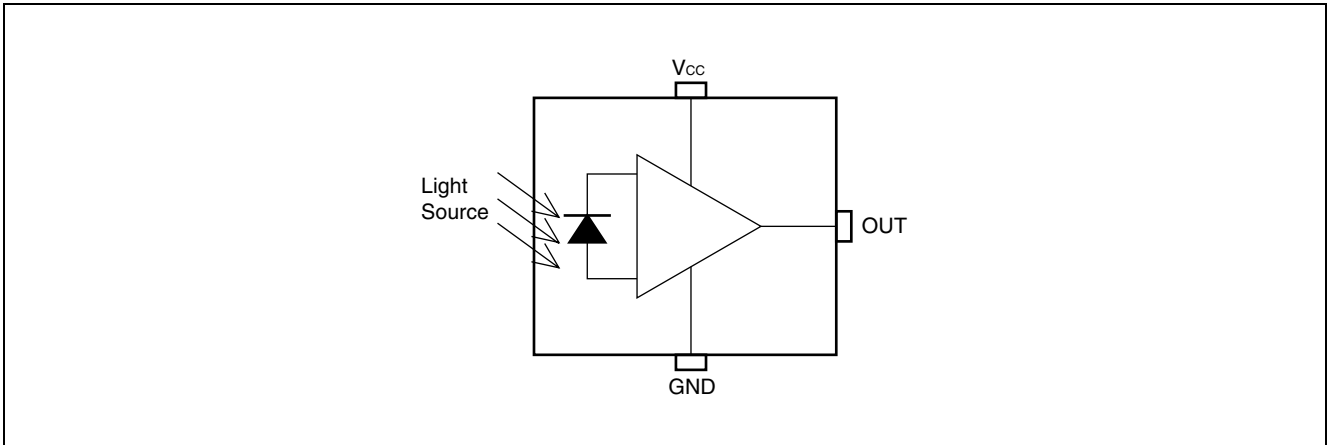

**MARKING EXAMPLE**

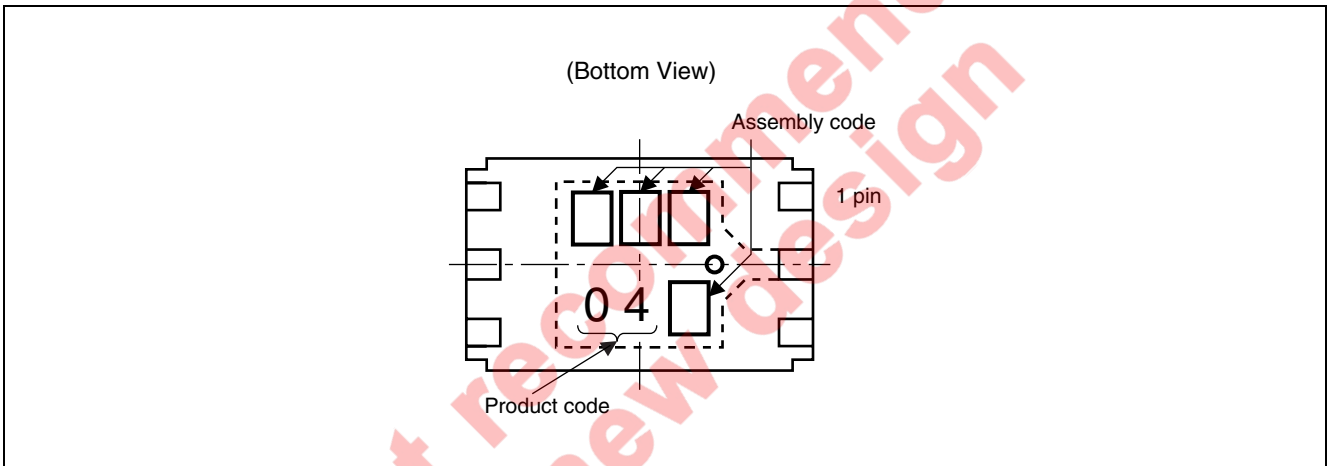

**ORDERING INFORMATION**

Part Number	Order Number	Solder Plating Specification	Packing Style
PH5504A2NA1-E4	PH5504A2NA1-E4-Y-A	Pb-Free	Embossed Tape 5 000 pcs/reel

**ABSOLUTE MAXIMUM RATINGS ( $T_A = 25^\circ\text{C}$ , unless otherwise specified)**

Parameter	Symbol	Ratings	Unit
Supply Voltage	$V_{CC}$	6	V
Light Current	$I_O$	5	mA
Power Dissipation *1	$P_D$	135	mW
Operating Temperature	$T_{opt}$	-30 to +85	$^\circ\text{C}$
Storage Temperature	$T_{stg}$	-40 to +100	$^\circ\text{C}$

Note: \*1. Mounted on glass epoxy board (18 mm × 13 mm × t0.8 mm)

**RECOMMENDED OPERATING CONDITIONS**

Parameter	Symbol	MIN.	TYP.	MAX.	Unit
Supply Voltage	$V_{CC}$	1.8	3.0	5.5	V

**ELECTRO-OPTICAL CHARACTERISTICS ( $T_A = 25^\circ\text{C}$ ,  $V_{CC} = 3.0\text{ V}$ , unless otherwise specified)**

Parameter	Symbol	Conditions	MIN.	TYP.	MAX.	Unit
Supply Current *1	$I_{CC}$	$E_V = 100\text{ lx}$ *2	–	63	–	$\mu\text{A}$
Peak Sensitivity Wavelength	$\lambda_p$	–	–	530	–	nm
Light Current *1	$I_{O0}$	$E_V = 0\text{ lx}$	–	–	0.2	$\mu\text{A}$
	$I_{O1}$	$E_V = 100\text{ lx}$ *2	44	55	66	$\mu\text{A}$
Sensitivity Ratio of Fluorescent/Incandescent	–	$E_V = 100\text{ lx}$	–	1	–	Multiple
Saturation Output Voltage *3	$V_O$	$E_V = 100\text{ lx}$ , $R_L = 150\text{ k}\Omega$ *2	2.6	2.9	–	V
Switching Time *4	Rise Time	$t_r$	–	80	–	$\mu\text{s}$
	Fall Time	$t_f$	–	140	–	$\mu\text{s}$
	Delay Time	$t_d$	–	250	–	$\mu\text{s}$
	Storage Time	$t_s$	–	5	–	$\mu\text{s}$

Note: \*1 Measured under load resistance conditions of an output current unsaturated

\*2 Fluorescent light

\*3 Saturation output voltage measurement method:

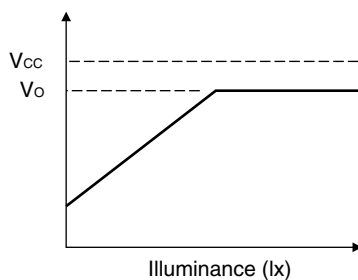
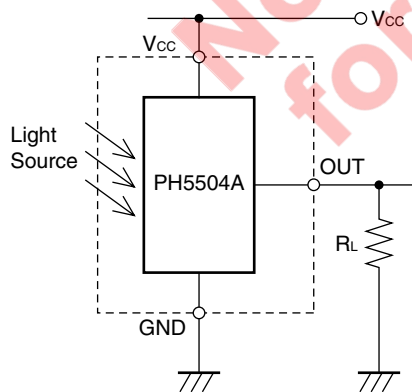

\*4 Switching Time

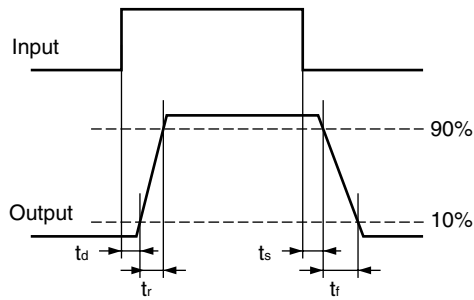
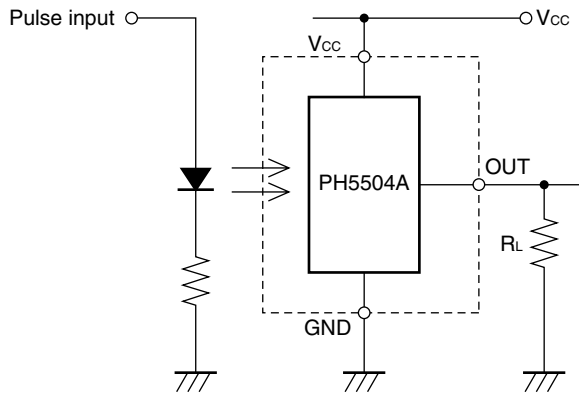

\*5 White LED

Not recommend  
for new design

**TYPICAL CHARACTERISTICS ( $T_A = 25^\circ\text{C}$ ,  $V_{CC} = 3.0\text{ V}$ , unless otherwise specified)**

**SPECTRAL SENSITIVITY CHARACTERISTICS**

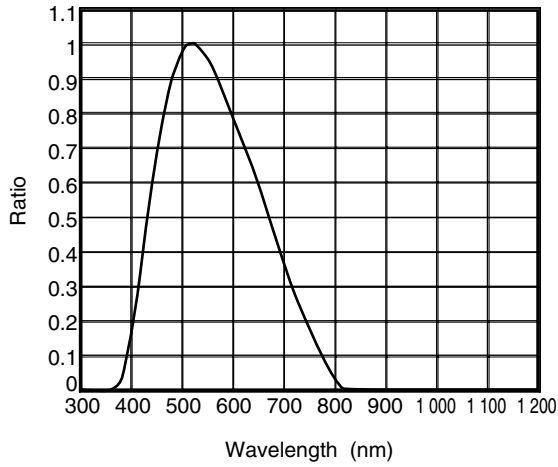

**LIGHT SOURCE SENSITIVITY VARIATION**

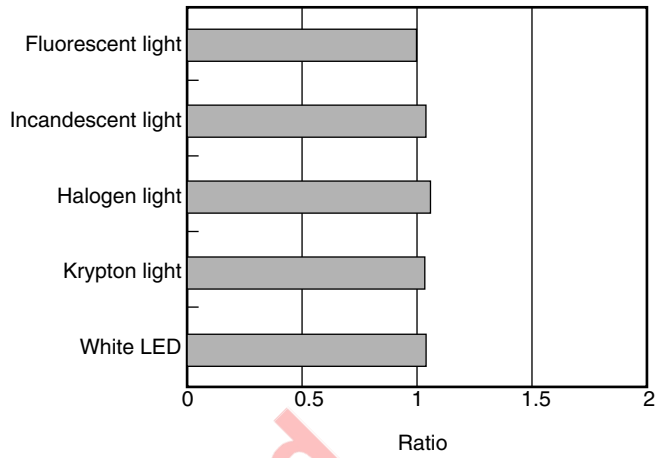

**DIRECTIONAL CHARACTERISTICS 1**

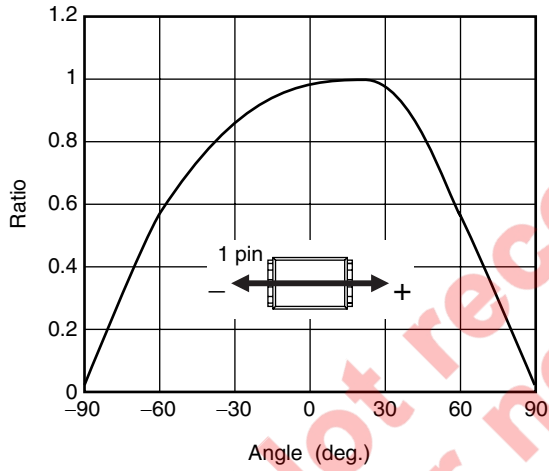

**DIRECTIONAL CHARACTERISTICS 2**

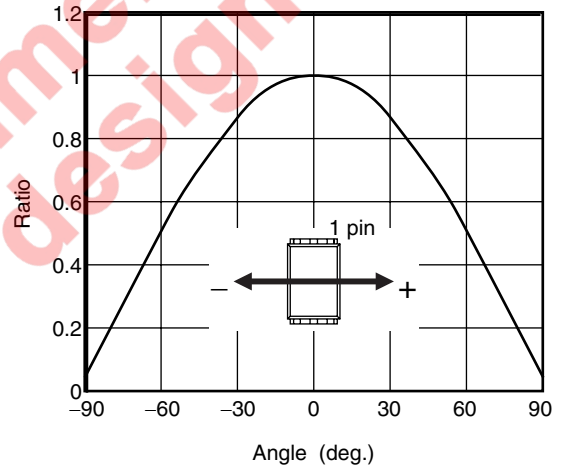

**Remark** The graphs indicate nominal characteristics.

LIGHT CURRENT vs. ILLUMINANCE

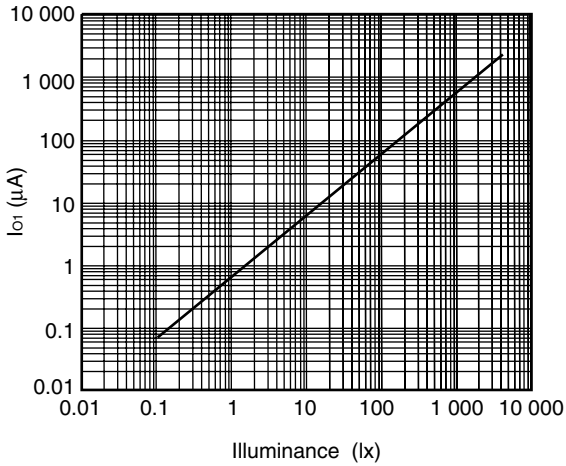

TEMPERATURE DEPENDENCY OF LIGHT CURRENT AT 0 lx

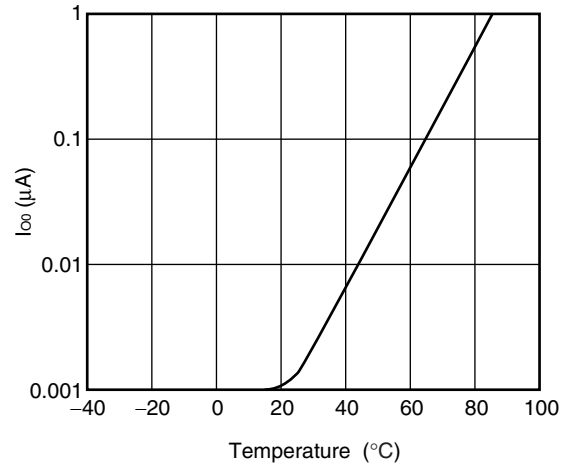

TEMPERATURE DEPENDENCY OF LIGHT CURRENT AT 100 lx (NORMALIZED AT 25°C)

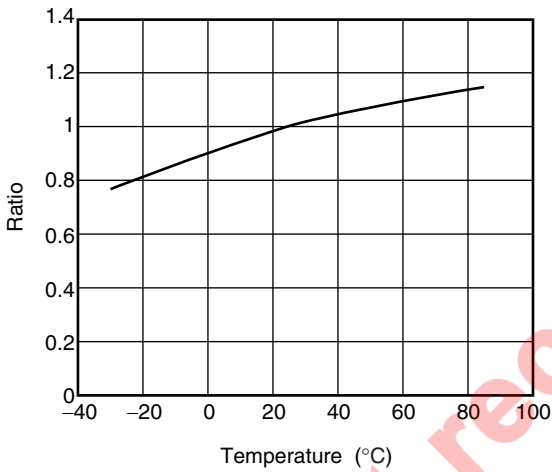

VCC DEPENDENCY OF LIGHT CURRENT AT 100 lx (NORMALIZED AT VCC = 3 V)

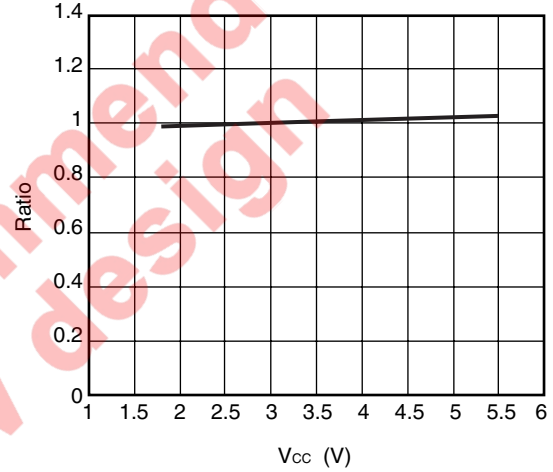

**Remark** The graphs indicate nominal characteristics.

RECOMMENDED OPTICAL LAYOUT (UNIT: mm)

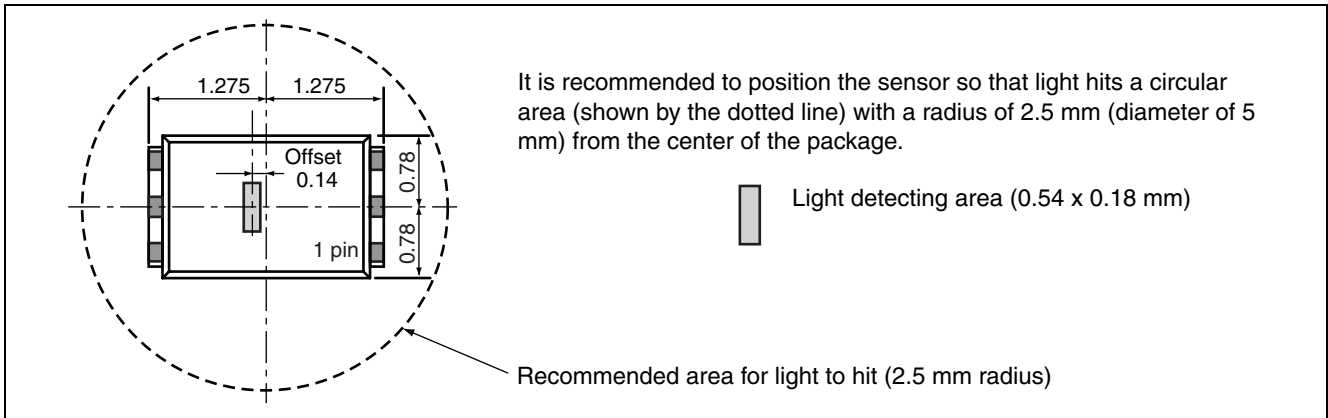

Not recommend  
for new design



TAPING SPECIFICATIONS (UNIT: mm)

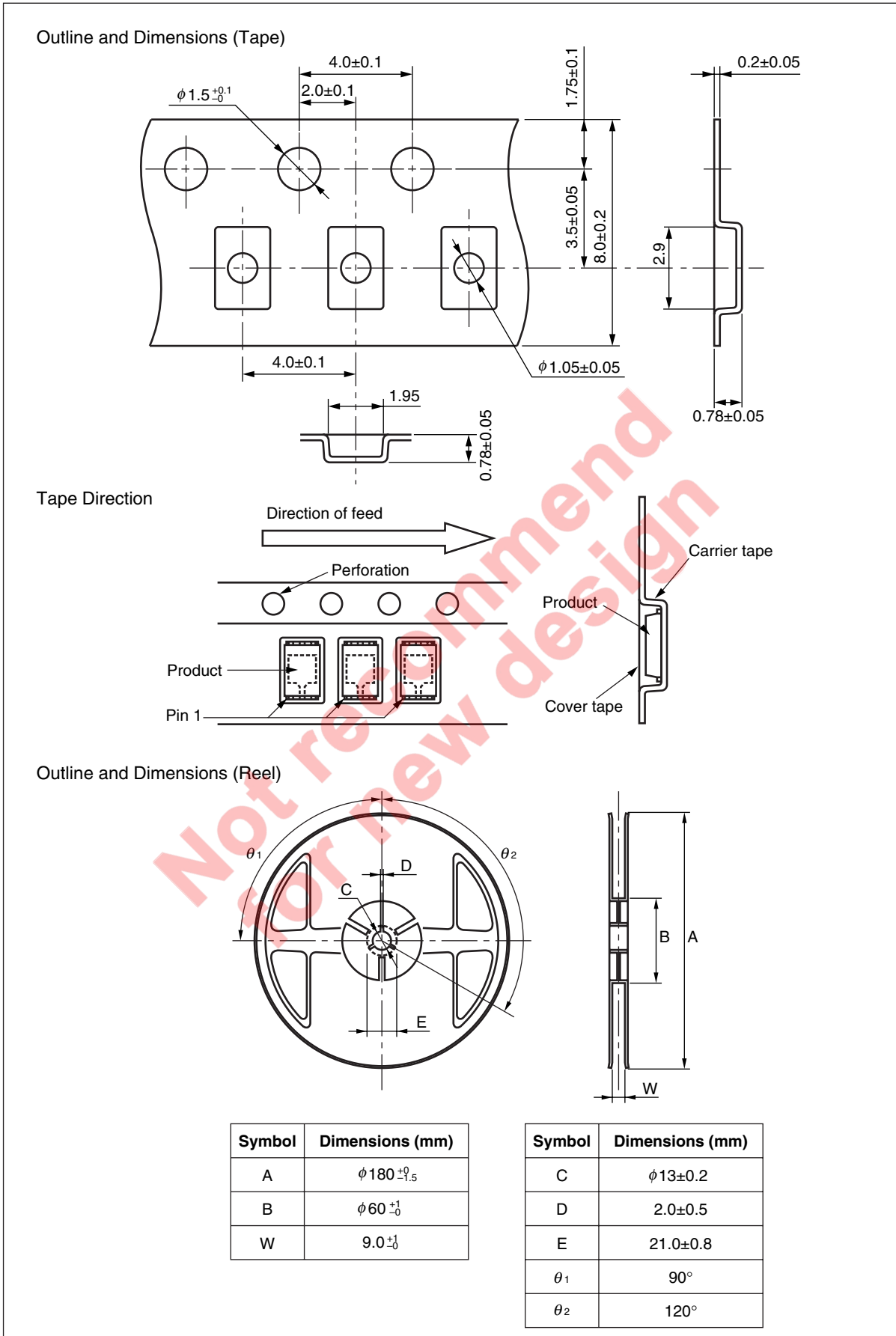

RECOMMENDED MOUNT PAD DIMENSIONS (Unit: mm)

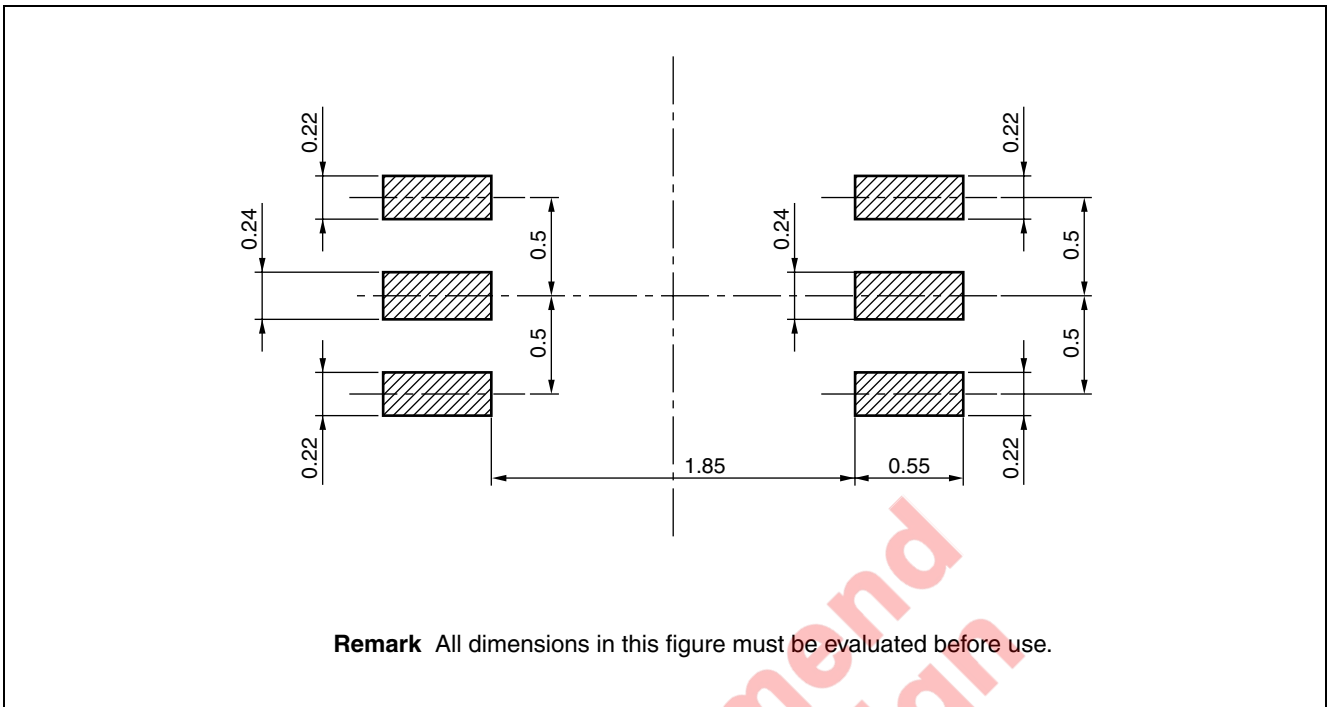

## NOTES ON HANDLING

### 1. Recommended reflow soldering conditions

(including infrared reflow, convection reflow, and infrared + convection reflow)

- (1) This product is dry-packed with desiccant in order to avoid moisture absorption.
- (2) After breaking the seal, reflow soldering must be done within 168 hours under the recommended temperature profile shown below.
- (3) If more than 168 hours have passed after breaking the seal, the baking process must be done by using a tape and reel.

Baking conditions: Once, with tape and reel,  $60\pm 5^{\circ}\text{C}$ , 10 to 24 hours

After the baking process, this product must be stored under conditions of  $30^{\circ}\text{C}$  or below, 70% RH or below, and reflow soldering must be done within 168 hours.

< Storage conditions after breaking seal >

- Storage conditions :  $30^{\circ}\text{C}$  or below, 70% RH or below
- Maximum storage period after breaking seal : 168 hours (Second reflow soldering must be completed within 168 hours.)

< Reflow soldering conditions >

- Peak reflow temperature :  $260^{\circ}\text{C}$  or below (Package surface temperature)
- Maximum number of reflows : 2
- No repair by hand soldering
- Maximum chlorine content of rosin flux (percentage mass) : 0.2% or less

Recommended Temperature Profile of Reflow

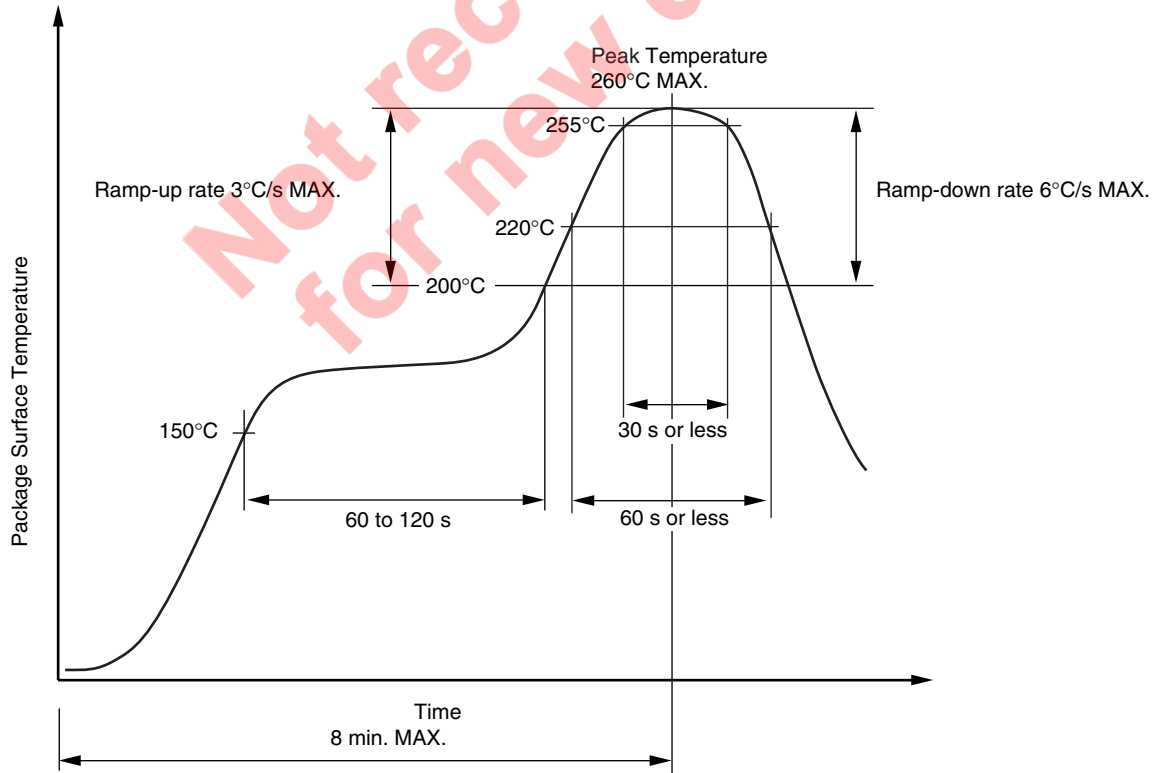

<b>Revision History</b>	<b>PH5504A2NA1 Data Sheet</b>
-------------------------	-------------------------------

Rev.	Date	Description	
		Page	Summary
1.00	Nov 05, 2012	-	First edition issued

Not recommend  
for new design

All trademarks and registered trademarks are the property of their respective owners.
---

## Notice

1. Descriptions of circuits, software and other related information in this document are provided only to illustrate the operation of semiconductor products and application examples. You are fully responsible for the incorporation of these circuits, software, and information in the design of your equipment. Renesas Electronics assumes no responsibility for any losses incurred by you or third parties arising from the use of these circuits, software, or information.
2. Renesas Electronics has used reasonable care in preparing the information included in this document, but Renesas Electronics does not warrant that such information is error free. Renesas Electronics assumes no liability whatsoever for any damages incurred by you resulting from errors in or omissions from the information included herein.
3. Renesas Electronics does not assume any liability for infringement of patents, copyrights, or other intellectual property rights of third parties by or arising from the use of Renesas Electronics products or technical information described in this document. No license, express, implied or otherwise, is granted hereby under any patents, copyrights or other intellectual property rights of Renesas Electronics or others.
4. You should not alter, modify, copy, or otherwise misappropriate any Renesas Electronics product, whether in whole or in part. Renesas Electronics assumes no responsibility for any losses incurred by you or third parties arising from such alteration, modification, copy or otherwise misappropriation of Renesas Electronics product.
5. Renesas Electronics products are classified according to the following two quality grades: "Standard" and "High Quality". The recommended applications for each Renesas Electronics product depends on the product's quality grade, as indicated below.  
"Standard": Computers; office equipment; communications equipment; test and measurement equipment; audio and visual equipment; home electronic appliances; machine tools; personal electronic equipment; and industrial robots etc.  
"High Quality": Transportation equipment (automobiles, trains, ships, etc.); traffic control systems; anti-disaster systems; anti-crime systems; and safety equipment etc.  
Renesas Electronics products are neither intended nor authorized for use in products or systems that may pose a direct threat to human life or bodily injury (artificial life support devices or systems, surgical implantations etc.), or may cause serious property damages (nuclear reactor control systems, military equipment etc.). You must check the quality grade of each Renesas Electronics product before using it in a particular application. You may not use any Renesas Electronics product for any application for which it is not intended. Renesas Electronics shall not be in any way liable for any damages or losses incurred by you or third parties arising from the use of any Renesas Electronics product for which the product is not intended by Renesas Electronics.
6. You should use the Renesas Electronics products described in this document within the range specified by Renesas Electronics, especially with respect to the maximum rating, operating supply voltage range, movement power voltage range, heat radiation characteristics, installation and other product characteristics. Renesas Electronics shall have no liability for malfunctions or damages arising out of the use of Renesas Electronics products beyond such specified ranges.
7. Although Renesas Electronics endeavors to improve the quality and reliability of its products, semiconductor products have specific characteristics such as the occurrence of failure at a certain rate and malfunctions under certain use conditions. Further, Renesas Electronics products are not subject to radiation resistance design. Please be sure to implement safety measures to guard them against the possibility of physical injury, and injury or damage caused by fire in the event of the failure of a Renesas Electronics product, such as safety design for hardware and software including but not limited to redundancy, fire control and malfunction prevention, appropriate treatment for aging degradation or any other appropriate measures. Because the evaluation of microcomputer software alone is very difficult, please evaluate the safety of the final products or systems manufactured by you.
8. Please contact a Renesas Electronics sales office for details as to environmental matters such as the environmental compatibility of each Renesas Electronics product. Please use Renesas Electronics products in compliance with all applicable laws and regulations that regulate the inclusion or use of controlled substances, including without limitation, the EU RoHS Directive. Renesas Electronics assumes no liability for damages or losses occurring as a result of your noncompliance with applicable laws and regulations.
9. Renesas Electronics products and technology may not be used for or incorporated into any products or systems whose manufacture, use, or sale is prohibited under any applicable domestic or foreign laws or regulations. You should not use Renesas Electronics products or technology described in this document for any purpose relating to military applications or use by the military, including but not limited to the development of weapons of mass destruction. When exporting the Renesas Electronics products or technology described in this document, you should comply with the applicable export control laws and regulations and follow the procedures required by such laws and regulations.
10. It is the responsibility of the buyer or distributor of Renesas Electronics products, who distributes, disposes of, or otherwise places the product with a third party, to notify such third party in advance of the contents and conditions set forth in this document, Renesas Electronics assumes no responsibility for any losses incurred by you or third parties as a result of unauthorized use of Renesas Electronics products.
11. This document may not be reproduced or duplicated in any form, in whole or in part, without prior written consent of Renesas Electronics.
12. Please contact a Renesas Electronics sales office if you have any questions regarding the information contained in this document or Renesas Electronics products, or if you have any other inquiries.  
(Note 1) "Renesas Electronics" as used in this document means Renesas Electronics Corporation and also includes its majority-owned subsidiaries.  
(Note 2) "Renesas Electronics product(s)" means any product developed or manufactured by or for Renesas Electronics.



### SALES OFFICES

Renesas Electronics Corporation

<http://www.renesas.com>

Refer to "<http://www.renesas.com/>" for the latest and detailed information.

**California Eastern Laboratories, Inc.**  
4590 Patrick Henry Drive, Santa Clara, California 95054, U.S.A.  
Tel: +1-408-919-2500, Fax: +1-408-988-0279

**Renesas Electronics Europe Limited**  
Dukes Meadow, Millboard Road, Bourne End, Buckinghamshire, SL8 5FH, U.K.  
Tel: +44-1628-651-700, Fax: +44-1628-651-804

**Renesas Electronics Europe GmbH**  
Arcadiastrasse 10, 40472 Düsseldorf, Germany  
Tel: +49-211-65030, Fax: +49-211-6503-1327

**Renesas Electronics (China) Co., Ltd.**  
7th Floor, Quantum Plaza, No.27 ZhiChunLu Haidian District, Beijing 100083, P.R.China  
Tel: +86-10-8235-1155, Fax: +86-10-8235-7679

**Renesas Electronics (Shanghai) Co., Ltd.**  
Unit 204, 205, AZIA Center, No.1233 Lujiazui Ring Rd., Pudong District, Shanghai 200120, China  
Tel: +86-21-5877-1818, Fax: +86-21-6887-7858 / -7898

**Renesas Electronics Hong Kong Limited**  
Unit 1601-1613, 16/F., Tower 2, Grand Century Place, 193 Prince Edward Road West, Mongkok, Kowloon, Hong Kong  
Tel: +852-2886-9318, Fax: +852 2886-9022/9044

**Renesas Electronics Taiwan Co., Ltd.**  
13F, No. 363, Fu Shing North Road, Taipei, Taiwan  
Tel: +886-2-8175-9600, Fax: +886 2-8175-9670

**Renesas Electronics Singapore Pte. Ltd.**  
80 Bendemeer Road, Unit #06-02 Hyflux Innovation Centre Singapore 339949  
Tel: +65-6213-0200, Fax: +65-6213-0300

**Renesas Electronics Malaysia Sdn.Bhd.**  
Unit 906, Block B, Menara Amcorp, Amcorp Trade Centre, No. 18, Jln Persiaran Barat, 46050 Petaling Jaya, Selangor Darul Ehsan, Malaysia  
Tel: +60-3-7955-9390, Fax: +60-3-7955-9510

**Renesas Electronics Korea Co., Ltd.**  
11F., Samik Lavied' or Bldg., 720-2 Yeoksam-Dong, Kangnam-Ku, Seoul 135-080, Korea  
Tel: +82-2-558-3737, Fax: +82-2-558-5141