

**Product Features**

**Common Features**

- PI74FCT16245T, PI74FCT162245T and PI74FCT162H245 are high-speed, low-power devices with high-current drive
- $V_{CC} = 5V \pm 10\%$
- Hysteresis on all inputs
- Packages available:
  - 48-pin 240 mil wide plastic TSSOP (A48)
  - 48-pin 173 mil wide plastic TVSOP (JEDEC TSSOP K48)
  - 48-pin 300 mil wide plastic SSOP (V48)

**PI74FCT16245T Features**

- High output drive:  $I_{OH} = -32mA$ ;  $I_{OL} = 64mA$
- Power off disable outputs permit “live insertion”
- Typical  $V_{OLP}$  (Output Ground Bounce)  $< 1.0V$  at  $V_{CC} = 5V$ ,  $T_A = 25^\circ C$

**PI74FCT162245T Features**

- Balanced output drivers:  $\pm 24mA$
- Reduced system switching noise
- Typical  $V_{OLP}$  (Output Ground Bounce)  $< 0.6V$  at  $V_{CC} = 5V$ ,  $T_A = 25^\circ C$

**PI74FCT162H245T Features**

- Bus Hold retains last active bus state during Three-State
- Eliminates the need for external pull-up resistors

**Product Description**

Pericom Semiconductor’s PI74FCT series of logic circuits are produced using the Company’s advanced 0.6 micron CMOS technology, achieving industry leading speed grades.

The PI74FCT16245T, PI74FCT162245T, and PI74FCT162H245T are 16-bit bidirectional transceivers designed for asynchronous two-way communication between data buses. The direction control input pin (xDIR) determines the direction of data flow through the bidirectional transceiver. The Direction and Output Enable controls are designed to operate these devices as either two independent 8-bit transceivers or one 16-bit transceiver. The output enable (OE) input, when HIGH, disables both A and B ports by placing them in HIGH Z condition.

The PI74FCT16245T output buffers are designed with a Power-Off disable allowing “live insertion” of boards when used as backplane drivers.

The PI74FCT162245T has  $\pm 24mA$  balanced output drivers. It is designed with current limiting resistors at its outputs to control the output edge rate resulting in lower ground bounce and undershoot. This eliminates the need for external terminating resistors for most interface applications.

The PI74FCT162H245T has “Bus Hold” which retains the input’s last state whenever the input goes to high-impedance preventing “floating” inputs and eliminating the need for pull-up/down resistors.

**Logic Block Diagram**

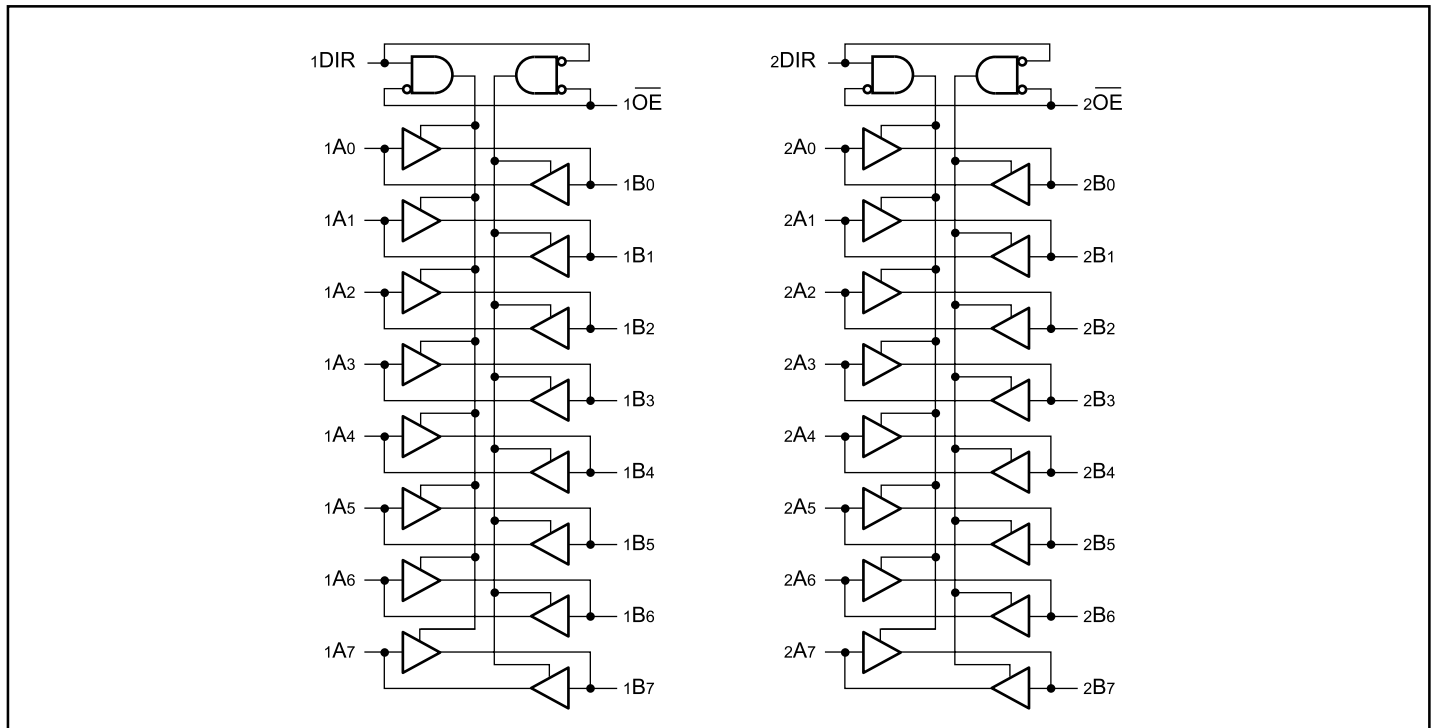



### Maximum Ratings

(Above which the useful life may be impaired. For user guidelines, not tested.)

Storage Temperature .....	-65°C to +150°C
Ambient Temperature with Power Applied .....	-40°C to +85°C
Supply Voltage to Ground Potential (Inputs & V <sub>CC</sub> Only) ..	-0.5V to +7.0V
Supply Voltage to Ground Potential (Outputs & D/O Only)	-0.5V to +7.0V
DC Input Voltage .....	-0.5V to +7.0V
DC Output Current .....	120mA
Power Dissipation .....	1.0W

**Note:**

Stresses greater than those listed under MAXIMUM RATINGS may cause permanent damage to the device. This is a stress rating only and functional operation of the device at these or any other conditions above those indicated in the operational sections of this specification is not implied. Exposure to absolute maximum rating conditions for extended periods may affect reliability.

### DC Electrical Characteristics (Over the Operating Range, T<sub>A</sub> = -40°C to +85°C, V<sub>CC</sub> = 5.0V ±10%)

Parameters	Description	Test Conditions <sup>(1)</sup>		Min.	Typ. <sup>(2)</sup>	Max.	Units
V <sub>IH</sub>	Input HIGH Voltage	Guaranteed Logic HIGH Level		2.0			V
V <sub>IL</sub>	Input LOW Voltage	Guaranteed Logic LOW Level				0.8	V
I <sub>IH</sub>	Input HIGH Current	Standard Input, V <sub>CC</sub> = Max.	V <sub>IN</sub> = V <sub>CC</sub>			1	μA
I <sub>IH</sub>	Input HIGH Current	Standard I/O, V <sub>CC</sub> = Max.	V <sub>IN</sub> = V <sub>CC</sub>			1	μA
I <sub>IH</sub>	Input HIGH Current	Bus Hold Input <sup>(4)</sup> , V <sub>CC</sub> = Max.	V <sub>IN</sub> = V <sub>CC</sub>			±100	μA
I <sub>IH</sub>	Input HIGH Current	Bus Hold I/O <sup>(4)</sup> , V <sub>CC</sub> = Max.	V <sub>IN</sub> = V <sub>CC</sub>			±100	μA
I <sub>IL</sub>	Input LOW Current	Standard Input, V <sub>CC</sub> = Min.	V <sub>IN</sub> = GND			-1	μA
I <sub>IL</sub>	Input LOW Current	Standard I/O, V <sub>CC</sub> = Min.	V <sub>IN</sub> = GND			-1	μA
I <sub>IL</sub>	Input LOW Current	Bus Hold Input <sup>(4)</sup> , V <sub>CC</sub> = Min.	V <sub>IN</sub> = GND			±100	μA
I <sub>IL</sub>	Input LOW Current	Bus Hold I/O <sup>(4)</sup> , V <sub>CC</sub> = Min.	V <sub>IN</sub> = GND			±100	μA
I <sub>BHH</sub>	Bus Hold	Bus Hold Input <sup>(4)</sup> , V <sub>CC</sub> = Min.	V <sub>IN</sub> = 2.0V	-50			μA
I <sub>BHL</sub>	Sustain Current		V <sub>IN</sub> = 0.8V	+50			
I <sub>OZH</sub> <sup>(5)</sup>	High Impedance	V <sub>CC</sub> = Max.	V <sub>OUT</sub> = 2.7V			1	μA
I <sub>OZL</sub> <sup>(5)</sup>	Output Current	V <sub>CC</sub> = Max.	V <sub>OUT</sub> = 0.5V			-1	μA
V <sub>IK</sub>	Clamp Diode Voltage	V <sub>CC</sub> = Min., I <sub>IN</sub> = -18mA			-0.7	-1.2	V
I <sub>OS</sub>	Short Circuit Current	V <sub>CC</sub> = Max. <sup>(3)</sup> , V <sub>OUT</sub> = GND		-80	-140	-200	mA
I <sub>O</sub>	Output Drive Current	V <sub>CC</sub> = Max. <sup>(3)</sup> , V <sub>OUT</sub> = 2.5V		-50		-180	mA
V <sub>H</sub>	Input Hysteresis				100		mV

**Notes:**

1. For Max. or Min. conditions, use appropriate value specified under Electrical Characteristics for the applicable device type.
2. Typical values are at V<sub>CC</sub> = 5.0V, +25°C ambient and maximum loading.
3. Not more than one output should be shorted at one time. Duration of the test should not exceed one second.
4. Pins with Bus Hold are identified in the pin description.
5. This specification does not apply to bi-directional functionalities with Bus Hold.

**PI74FCT16245T Output Drive Characteristics** (Over the Operating Range)

Parameters	Description	Test Conditions <sup>(1)</sup>		Min.	Typ. <sup>(2)</sup>	Max.	Units
VOH	Output HIGH Voltage	VCC = Min., VIN = VIH or VIL	IOH = -3.0mA	2.5	3.5		V
			IOH = -15.0mA	2.4	3.5		
			IOH = -32.0mA	2.0	3.0		
VOL	Output LOW Voltage	VCC = Min., VIN = VIH or VIL	IOL = 64mA		0.2	0.55	V
IOFF	Power Down Disable	VCC = 0V, VIN or VOUT ≤ 4.5V		—	—	±100	µA

**PI74FCT162245T/162H245T Output Drive Characteristics** (Over the Operating Range)

Parameters	Description	Test Conditions <sup>(1)</sup>		Min.	Typ. <sup>(2)</sup>	Max.	Units
VOH	Output HIGH Voltage	VCC = Min., VIN = VIH or VIL	IOH = -24.0mA	2.4	3.3		V
VOL	Output LOW Voltage	VCC = Min., VIN = VIH or VIL	IOL = 24mA		0.3	0.55	V
IODL	Output LOW Current	VCC = 5V, VIN = VIH OR VIL, VOUT = 1.5V <sup>(3)</sup>		60	115	150	mA
IODH	Output HIGH Current	VCC = 5V, VIN = VIH OR VIL, VOUT = 1.5V <sup>(3)</sup>		-60	-115	-150	mA

**Capacitance** (TA = 25°C, f = 1 MHz)

Parameters <sup>(4)</sup>	Description	Test Conditions	Typ.	Max.	Units
CIN	Input Capacitance	VIN = 0V	4.5	6	pF
COUT	Output Capacitance	VOUT = 0V	5.5	8	pF

**Notes:**

1. For Max. or Min. conditions, use appropriate value specified under Electrical Characteristics for the applicable device type.
2. Typical values are at Vcc = 5.0V, +25°C ambient and maximum loading.
3. Not more than one output should be shorted at one time. Duration of the test should not exceed one second.
4. This parameter is determined by device characterization but is not production tested.

### Power Supply Characteristics

Parameters	Description	Test Conditions <sup>(1)</sup>		Min.	Typ. <sup>(2)</sup>	Max.	Units
I <sub>CC</sub>	Quiescent Power Supply Current	V <sub>CC</sub> = Max.	V <sub>IN</sub> = GND or V <sub>CC</sub>		0.1	500	μA
ΔI <sub>CC</sub>	Supply Current per Input @ TTL HIGH	V <sub>CC</sub> = Max.	V <sub>IN</sub> = 3.4V <sup>(3)</sup>		0.5	1.5	mA
I <sub>CCD</sub>	Supply Current per Input per MHz <sup>(4)</sup>	V <sub>CC</sub> = Max., Outputs Open x $\overline{OE}$ = xDIR = GND One Bit Toggling 50% Duty Cycle	V <sub>IN</sub> = V <sub>CC</sub> V <sub>IN</sub> = GND		60	100	μA/ MHz
I <sub>C</sub>	Total Power Supply Current <sup>(6)</sup>	V <sub>CC</sub> = Max., Outputs Open f <sub>i</sub> = 10 MHz 50% Duty Cycle x $\overline{OE}$ = xDIR = GND One Bit Toggling	V <sub>IN</sub> = V <sub>CC</sub> V <sub>IN</sub> = GND		0.7	2.5 <sup>(5)</sup>	mA
			V <sub>IN</sub> = 3.4V V <sub>IN</sub> = GND		0.9	3.3 <sup>(5)</sup>	
		V <sub>CC</sub> = Max., Outputs Open f <sub>i</sub> = 2.5 MHz 50% Duty Cycle x $\overline{OE}$ = xDIR = GND 16 Bits Toggling	V <sub>IN</sub> = V <sub>CC</sub> V <sub>IN</sub> = GND		2.5	5.5 <sup>(5)</sup>	
			V <sub>IN</sub> = 3.4V V <sub>IN</sub> = GND		6.5	17.5 <sup>(5)</sup>	

#### Notes:

- For Max. or Min. conditions, use appropriate value specified under Electrical Characteristics for the applicable device.
- Typical values are at V<sub>CC</sub> = 5.0V, +25°C ambient.
- Per TTL driven input (V<sub>IN</sub> = 3.4V); all other inputs at V<sub>CC</sub> or GND.
- This parameter is not directly testable, but is derived for use in Total Power Supply Calculations.
- Values for these conditions are examples of the I<sub>CC</sub> formula. These limits are guaranteed but not tested.

$$I_C = I_{\text{QUIESCENT}} + I_{\text{INPUTS}} + I_{\text{DYNAMIC}}$$

$$I_C = I_{CC} + \Delta I_{CC} \text{DHNT} + I_{CCD} (f_{CP}/2 + f_i N_i)$$

I<sub>CC</sub> = Quiescent Current

ΔI<sub>CC</sub> = Power Supply Current for a TTL High Input (V<sub>IN</sub> = 3.4V)

DH = Duty Cycle for TTL Inputs High

NT = Number of TTL Inputs at DH

I<sub>CCD</sub> = Dynamic Current Caused by an Input Transition Pair (HLH or LHL)

f<sub>CP</sub> = Clock Frequency for Register Devices (Zero for Non-Register Devices)

f<sub>i</sub> = Input Frequency

N<sub>i</sub> = Number of Inputs at f<sub>i</sub>

All currents are in milliamps and all frequencies are in megahertz.



PI74FCT16245T Switching Characteristics over Operating Range

Parameters	Description	Conditions <sup>(1)</sup>	16245T		16245AT		16245CT		16245DT		16245ET		Units
			Com.		Com.		Com.		Com.		Com.		
			Min.	Max.	Min.	Max.	Min.	Max.	Min.	Max.	Min.	Max.	
tPLH tPHL	Propagation Delay <sup>(2)</sup> A TO B, B TO A	CL = 50pF RL = 500Ω	1.5	7.0	1.5	4.6	1.5	4.1	1.5	3.8	1.5	3.2	ns
tpZH tpZL	Output Enable Time xOE to A OR B		1.5	9.5	1.5	6.2	1.5	5.8	1.5	5.0	1.5	4.4	ns
tpHZ tPLZ	Output Disable Time <sup>(3)</sup> xOE to A OR B		1.5	7.5	1.5	5.0	1.5	4.8	1.5	4.3	1.5	4.0	ns
tpZH tpZL	Output Enable Time xDIR to A OR B <sup>(3)</sup>		1.5	9.5	1.5	6.2	1.5	5.8	1.5	5.0	1.5	4.8	ns
tpHZ tPLZ	Output Disable Time xDIR to A OR B <sup>(3)</sup>		1.5	7.5	1.5	5.0	1.5	4.8	1.5	4.3	1.5	4.0	ns
tsk(o)	Output Skew <sup>(4)</sup>		—	0.5	—	0.5	—	0.5	—	0.5	—	0.5	ns

PI74FCT162245T Switching Characteristics over Operating Range

Parameters	Description	Conditions <sup>(1)</sup>	162245T		162245AT		162245CT		162245DT		162245ET		Units
			Com.		Com.		Com.		Com.		Com.		
			Min.	Max.	Min.	Max.	Min.	Max.	Min.	Max.	Min.	Max.	
tPLH tPHL	Propagation Delay <sup>(2)</sup> A TO B, B TO A	CL = 50pF RL = 500Ω	1.5	7.0	1.5	4.6	1.5	4.1	1.5	3.8	1.5	3.2	ns
tpZH tpZL	Output Enable Time xOE to A OR B		1.5	9.5	1.5	6.2	1.5	5.8	1.5	5.0	1.5	4.4	ns
tpHZ tPLZ	Output Disable Time <sup>(3)</sup> xOE to A OR B		1.5	7.5	1.5	5.0	1.5	4.8	1.5	4.3	1.5	4.0	ns
tpZH tpZL	Output Enable Time xDIR to A OR B <sup>(3)</sup>		1.5	9.5	1.5	6.2	1.5	5.8	1.5	5.0	1.5	4.8	ns
tpHZ tPLZ	Output Disable Time xDIR to A OR B <sup>(3)</sup>		1.5	7.5	1.5	5.0	1.5	4.8	1.5	4.3	1.5	4.0	ns
tsk(o)	Output Skew <sup>(4)</sup>		—	0.5	—	0.5	—	0.5	—	0.5	—	0.5	ns

PI74FCT162H245T Switching Characteristics over Operating Range

Parameters	Description	Conditions <sup>(1)</sup>	162245T		162245AT		162245CT		162245DT		162245ET		Units
			Com.		Com.		Com.		Com.		Com.		
			Min.	Max.	Min.	Max.	Min.	Max.	Min.	Max.	Min.	Max.	
tPLH tPHL	Propagation Delay <sup>(2)</sup> A TO B, B TO A	CL = 50pF RL = 500Ω	1.5	7.0	1.5	4.6	1.5	4.1	1.5	3.8	1.5	3.2	ns
tpZH tpZL	Output Enable Time xOE to A OR B		1.5	9.5	1.5	6.2	1.5	5.8	1.5	5.0	1.5	4.4	ns
tpHZ tPLZ	Output Disable Time <sup>(3)</sup> xOE to A OR B		1.5	7.5	1.5	5.0	1.5	4.8	1.5	4.3	1.5	4.0	ns
tpZH tpZL	Output Enable Time xDIR to A OR B <sup>(3)</sup>		1.5	9.5	1.5	6.2	1.5	5.8	1.5	5.0	1.5	4.8	ns
tpHZ tPLZ	Output Disable Time xDIR to A OR B <sup>(3)</sup>		1.5	7.5	1.5	5.0	1.5	4.8	1.5	4.3	1.5	4.0	ns
tsk(o)	Output Skew <sup>(4)</sup>		—	0.5	—	0.5	—	0.5	—	0.5	—	0.5	ns

Notes:

1. See test circuit and waveforms.
2. Minimum limits are guaranteed but not tested on Propagation Delays.
3. This parameter is guaranteed but not production tested.
4. Skew between any two outputs, of the same package, switching in the same direction.  
This parameter is guaranteed by design.

Pericom Semiconductor Corporation

2380 Bering Drive • San Jose, CA 95131 • 1-800-435-2336 • Fax (408) 435-1100 • <http://www.pericom.com>