

### Features

PJM60H04NTF, the silicon N-channel enhanced VDMOSFET, is obtained by the self-aligned planar technology which reduce the conduction loss, improve switching performance and enhance the avalanche energy.

- Fast switching
- ESD improved capability  
HBM 2KV
- Low on resistance
- Low gatecharge
- Low reverse transfer capacitances
- 100% single pulse avalanche energy test
- $V_{DSS}=600V$   
 $I_D=4 A$   
 $P_D=30W$   
 $R_{DS(on)(TYP)}=1.7\Omega$

### Applications

- Power switch circuit of adaptor and charger

### PJM60H04NTF Explanation

PJ: Brand abbreviation of PingJing

M: MOSFET

60H04: Product type

N:Channel type

TF:Package type

### Absolute Maximum Ratings ( $T_C=25^\circ C$ unless otherwise specified)

Symbol	Parameter	Rating	Units
$V_{DSS}$	Drain-to-Source Voltage	600	V
$I_D$	Continuous Drain Current	4	A
	Continuous Drain Current $T_C=100^\circ C$	3.2	A
$I_{DM}^{a1}$	Pulsed Drain Current	16	A
$V_{GS}$	Gate-to-Source Voltage	$\pm 30$	V
$E_{AS}^{a2}$	Single Pulse Avalanche Energy	280	mJ
$E_{AR}^{a1}$	Avalanche Energy ,Repetitive	30	mJ
$I_{AR}^{a1}$	Avalanche Current	2.5	A
$dv/dt^{a3}$	Peak Diode Recovery $dv/dt$	5.0	V/ns
$P_D$	Power Dissipation	30	W
	Derating Factor above $25^\circ C$	0.24	W/ $^\circ C$
$T_J, T_{stg}$	Operating Junction and Storage Temperature Range	150 , -55 to 150	$^\circ C$
$T_L$	Maximum Temperature for Soldering	300	$^\circ C$

a1 : Repetitive rating; pulse width limited by maximum junction temperature

a2 :  $L=10mH, I_D=6.9A, Start T_J=25^\circ C$

a3 :  $I_{SD}=4A, di/dt \leq 100A/us, V_{DD} \leq BV_{DS}, Start T_J=25^\circ C$

TO-220F

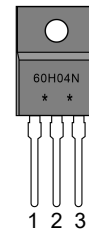

Marking

60H04N: Product type

\* \*: Date of manufacture

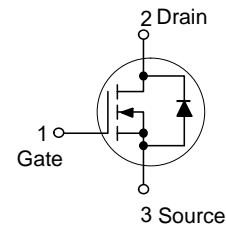



### Thermal Characteristics

Symbol	Parameter	Rating	Units
$R_{\theta JC}$	Thermal Resistance, Junction-to-Case	4.17	$^{\circ}\text{C}/\text{W}$
$R_{\theta JA}$	Thermal Resistance, Junction-to-Ambient	100	$^{\circ}\text{C}/\text{W}$

### Electrical Characteristics ( $T_J=25^{\circ}\text{C}$ unless otherwise specified)

Symbol	Parameter	Test Conditions	Rating			Units
			Min.	Typ.	Max.	
<b>Off Characteristics</b>						
$V_{DSS}$	Drain to Source Breakdown Voltage	$V_{GS}=0V, I_D=250\mu A$	600	--	--	V
$\Delta BV_{DSS}/\Delta T_J$	Bvdss Temperature Coefficient	$I_D=250\mu A, \text{Reference } 25^{\circ}\text{C}$	--	0.67	--	$\text{V}/^{\circ}\text{C}$
$I_{DSS}$	Drain to Source Leakage Current	$V_{DS}=600V, V_{GS}=0V, T_a=25^{\circ}\text{C}$	--	--	1	$\mu A$
		$V_{DS}=480V, V_{GS}=0V, T_a=125^{\circ}\text{C}$	--	--	100	
$I_{GSS(F)}$	Gate to Source Forward Leakage	$V_{GS}=+30V$	--	--	100	nA
$I_{GSS(R)}$	Gate to Source Reverse Leakage	$V_{GS}=-30V$	--	--	-100	nA
<b>On Characteristics</b>						
$R_{DS(ON)}$	Drain-to-Source On-Resistance	$V_{GS}=10V, I_D=2A$	--	1.7	2.3	$\Omega$
$V_{GS(TH)}$	Gate Threshold Voltage	$V_{DS}=V_{GS}, I_D=250\mu A$	2.0	--	4.0	V
Pulse width $t_p \leq 300\mu s, \delta \leq 2\%$						
<b>Dynamic Characteristics</b>						
$g_{fs}$	Forward Trans conductance	$V_{DS}=15V, I_D=2.0A$	--	2.5	--	S
$C_{iss}$	Input Capacitance	$V_{GS}=0V, V_{DS}=25V, f=1.0\text{MHz}$	--	544	--	$\text{pF}$
$C_{oss}$	Output Capacitance		--	55	--	
$C_{rss}$	Reverse Transfer Capacitance		--	8.5	--	
<b>Resistive Switching Characteristics</b>						
$t_{d(ON)}$	Turn-on Delay Time	$I_D=4.0A, V_{DD}=300V, R_g=4.7\Omega$	--	8.5	--	ns
$t_r$	Rise Time		--	6.5	--	
$t_{d(OFF)}$	Turn-Off Delay Time		--	31	--	
$t_f$	Fall Time		--	8.5	--	
$Q_g$	Total Gate Charge	$I_D=4.0A, V_{DD}=300V, V_{GS}=10V$	--	14.5	--	nC
$Q_{gs}$	Gate to Source Charge		--	2.8	--	
$Q_{gd}$	Gate to Drain ("Miller") Charge		--	6.3	--	
<b>Source-Drain Diode Characteristics</b>						
$I_{SD}$	Continuous Source Current (Body Diode)		--	--	4	A
$I_{SM}$	Maximum Pulsed Current (Body Diode)		--	--	16	A
$V_{SD}$	Diode Forward Voltage	$I_S=4.0A, V_{GS}=0V$	--	--	1.5	V
$t_{rr}$	Reverse Recovery Time	$I_S=4.0A, T_J=25^{\circ}\text{C}$ $dI_F/dt=100A/\mu s, V_{GS}=0V$	--	430	--	ns
$Q_{rr}$	Reverse Recovery Charge		--	1270	--	nC
Pulse width $t_p \leq 300\mu s, \delta \leq 2\%$						



**Typical Characteristic Curves**

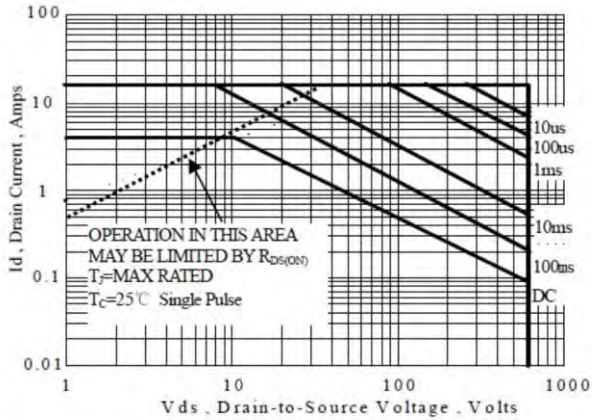

Figure 1 Maximum Forward Bias Safe Operating Area

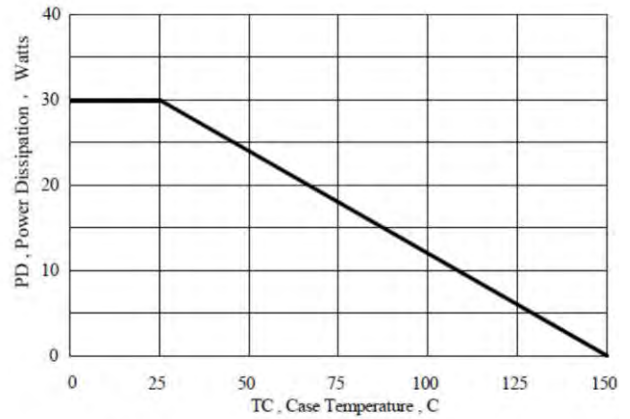

Figure 2 Maximum Power Dissipation vs Case Temperature

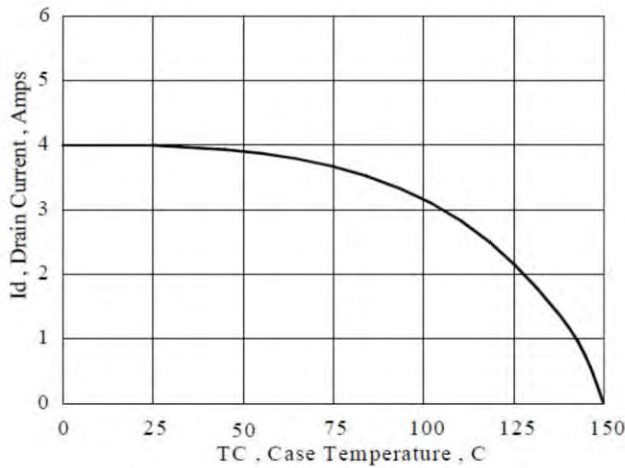

Figure 3 Maximum Continuous Drain Current vs Case Temperature

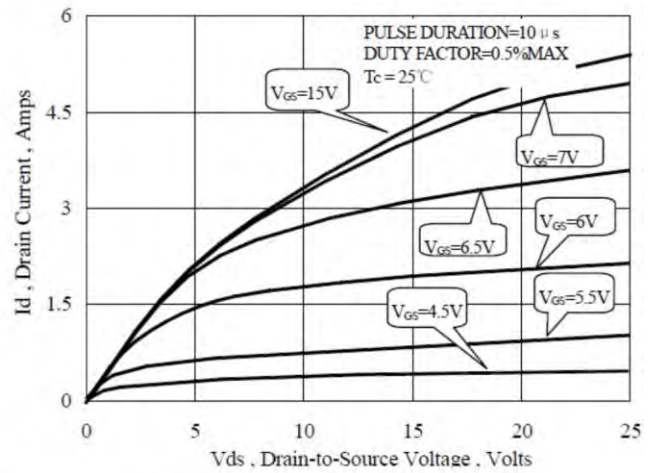

Figure 4 Typical Output Characteristics

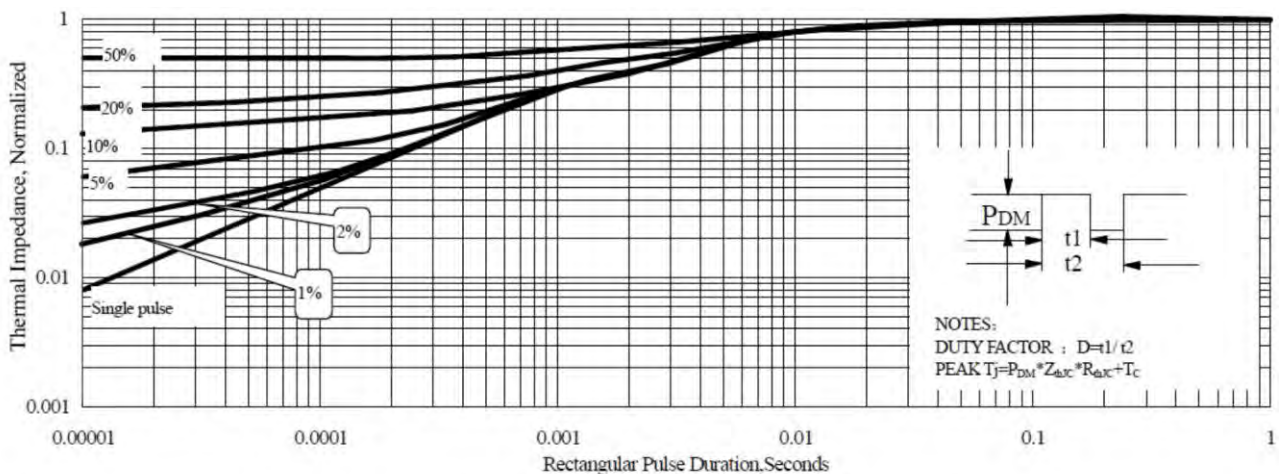

Figure 5 Maximum Effective Thermal Impedance, Junction to Case

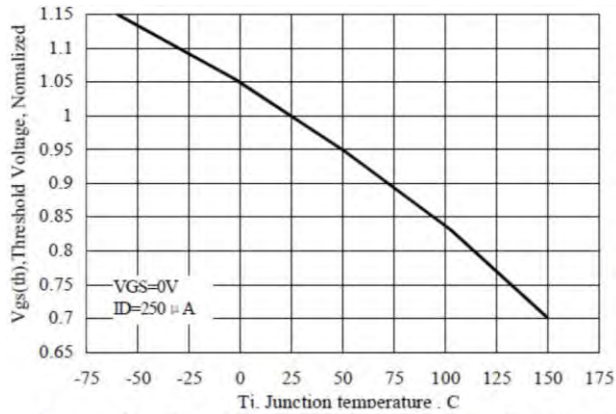

Figure 11 Typical Theshold Voltage vs Junction Temperature

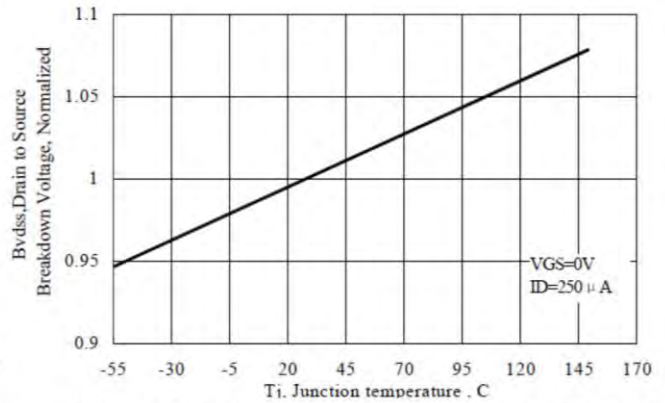

Figure 12 Typical Breakdown Voltage vs Junction Temperature

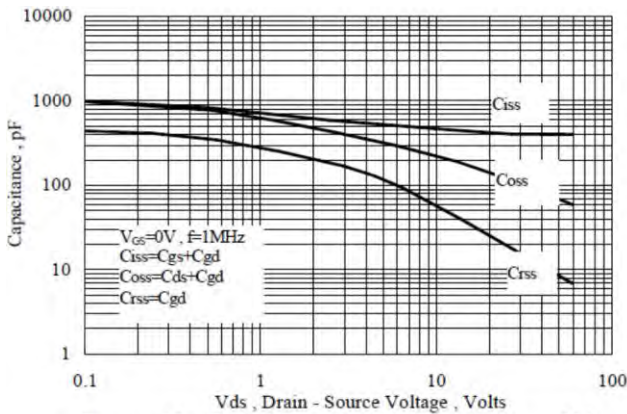

Figure 13 Typical Capacitance vs Drain to Source Voltage

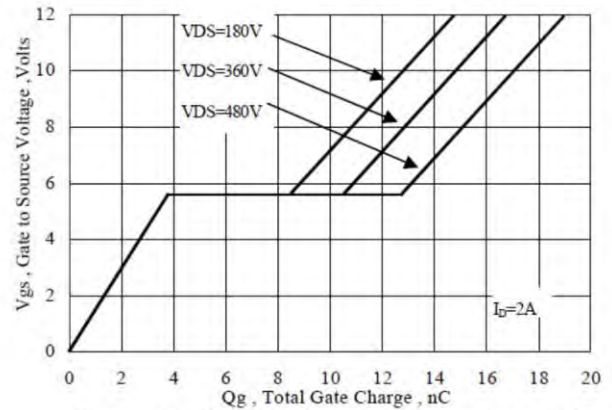

Figure 14 Typical Gate Charge vs Gate to Source Voltage

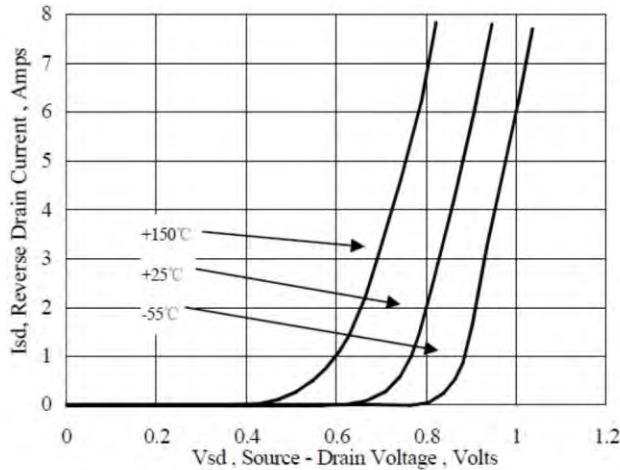

Figure 15 Typical Body Diode Transfer Characteristics

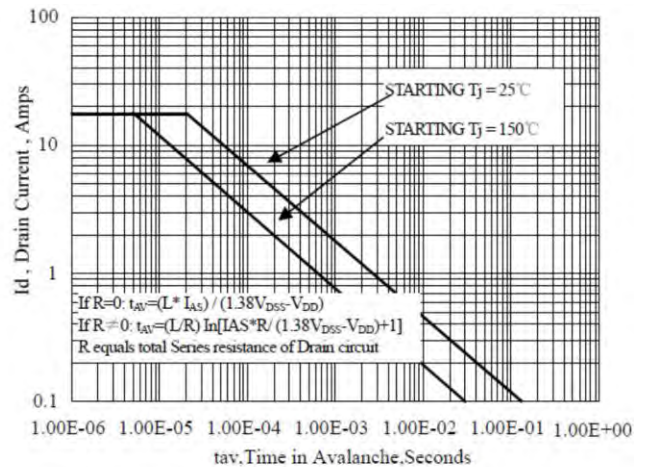

Figure 16 Unclamped Inductive Switching Capability



**Package Outline**

TO-220F  
unit:mm

SYMBOL	min	nom	max	SYMBOL	min	nom	max
A	9.80		10.60	D		2.54	
A1		7.00		D1	1.15		1.55
A2	2.90		3.40	D2	0.60		1.00
A3	9.10		9.90	D3	0.20		0.50
B1	15.40		16.40	E	2.24		2.84
B2	4.35		4.95	E1		0.70	
B3	6.00		7.40	E2		1.0×45°	
C	3.00		3.70	E3	0.35		0.65
C1	15.00		17.00	E4	2.30		3.30
C2	8.80		10.80	α (度)		30°	

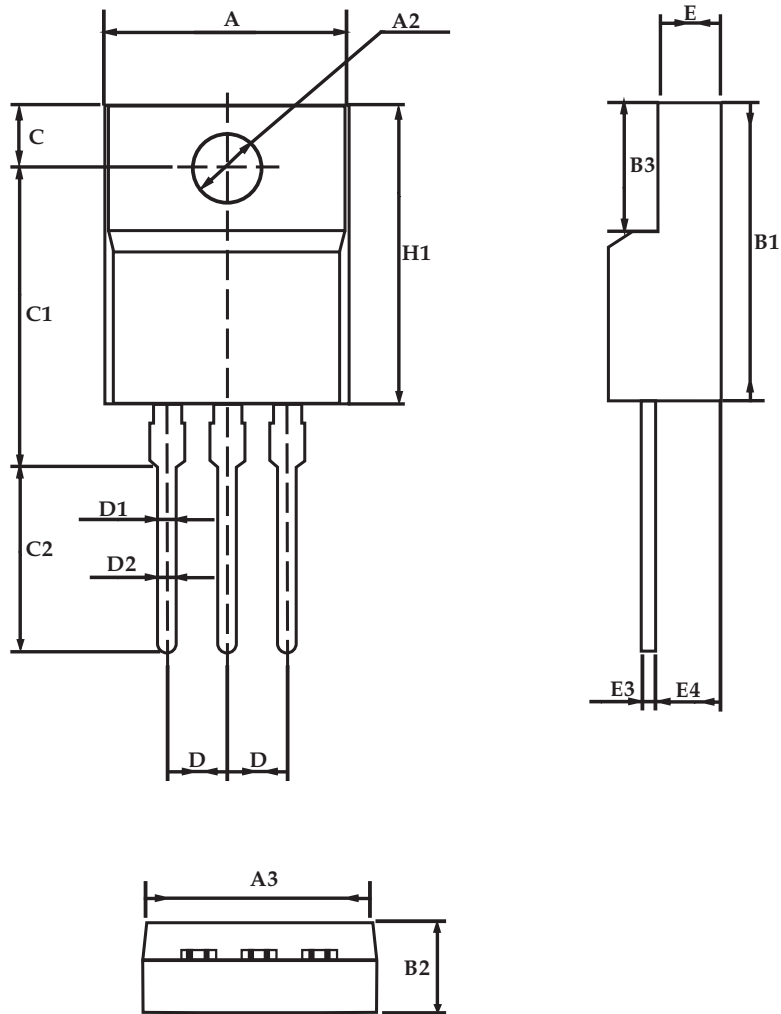



## Conditions of soldering

- Recommended condition of flow soldering

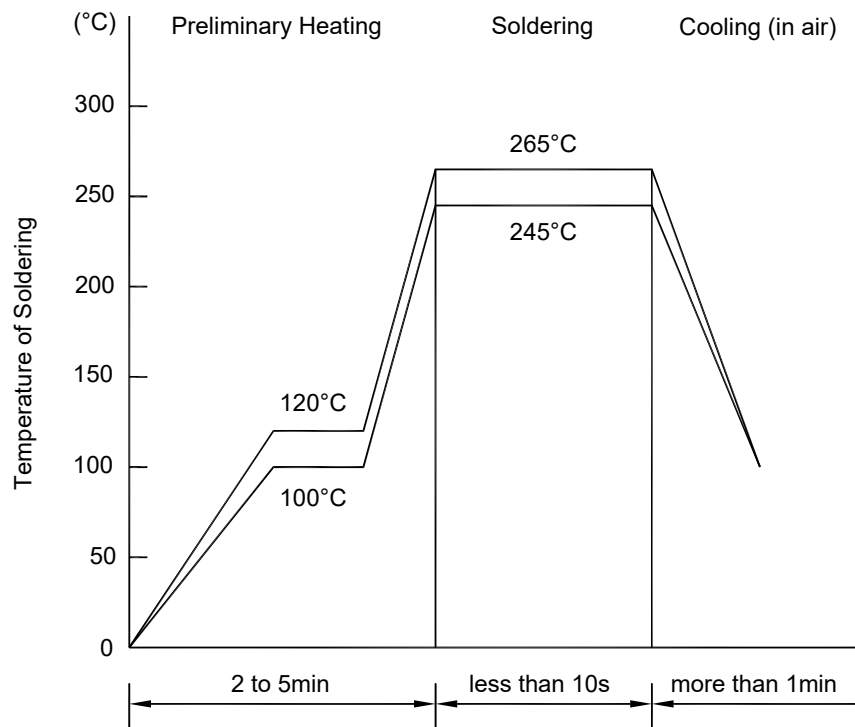

## Condition of hand soldering

Temperature: 370 °C

Time: 3s max.

Times: one time

**MSL: 1 Level**



### Packaging Specifications of Tube Pack for TO-220/TO-220F

1. The method of packaging and dimension are shown as below figure. (Dimension in mm)

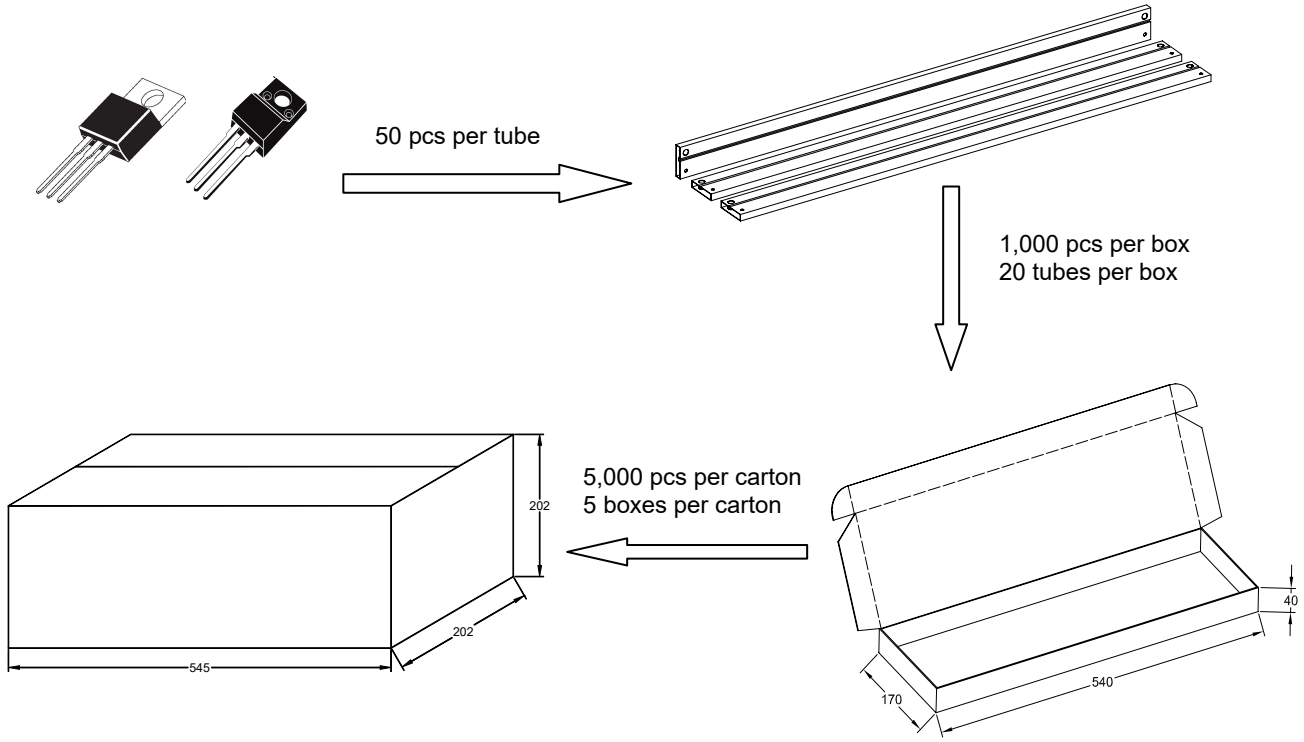

2. Tube data (Units: mm)

