



NXP Nexperia single-chip GSM/GPRS ultra-low-cost solution PNX4902 with triband and Bluetooth support

Enable a new generation of feature-rich ULC+ phones

This single-chip GSM/GPRS solution delivers enhanced multimedia and connectivity features to ultra-low-cost handsets. Building on the groundbreaking PNX4901, it adds triband and Bluetooth support, extensive peripheral support, and a high-performance 8-Ω driver for handsfree operation.

Key features

- ▶ Complete GSM/GPRS solution in a single monolithic IC
 - Digital and analog baseband, RF transceiver, audio codec, and power management
 - Powerful 32-bit ARM926EJ-S core
 - High-performance 16-bit DSP core
 - Low-power, high-performance 0.13-μm CMOS process
- ▶ Telecom features
 - GPRS classes 1-10, classes B and C
 - SAIC for increased network capacity
 - A5/1, A5/2, A5/3 encryption
 - TTY/CTM support
 - R99 protocol stack, mature and field-tested worldwide
- ▶ Completely integrated RF transceiver
 - Triband Rx and Tx (GSM 850 or E-GSM 900, and DSC 1800, PCS 1900)
 - Proven, industry-leading Aero4210 transceiver core
 - Best-in-class performance
- ▶ Complete PMU subsystem
 - Integrated battery-charging circuitry
 - Integrates all voltage regulators (LDOs and DC/DC)
- ▶ Integrated audio subsystem
 - 40-voice polyphonic MIDI + MP3 ringtones
 - Microphone amplifier with two differential inputs
 - Three audio output amplifiers, including high-performance 8-Ω driver
 - Speakerphone echo cancellation and noise suppression
- ▶ Integrated connectivity and peripheral support
 - Support for external Bluetooth IC
 - Support for external FM tuner
 - SD/MMC support
 - Touchscreen support
 - I²C-bus, SPI, two UARTs, PCM, PWM
 - 1.8/3-V SIM card interface
 - Color LCD up to 176 x 200 pixels, 65k colors
- ▶ Hardware security based on 128-bit RSA
 - Robust yet flexible mechanism for SIM lock, Flash lock
- ▶ Standard RoHS-compliant package
 - 273-ball PBGA (10 x 10 mm, 0.5-mm pitch)

The PNX4902 is a second-generation solution that enables high-quality, feature-rich handsets at an ultra-low cost. Using the highly successful PNX4901 as its basis, it offers triband operation, increased connectivity options (including support for Bluetooth), and a high-performance 8-Ω driver for handsfree operation.

The result is a phone that offers highly desirable features at a dramatically lower price point than previously achievable, and expanding the reach of these technologies to millions more consumers in emerging and developed markets. The PNX4902 lets OEMs and ODMs differentiate themselves and their products in a fiercely competitive market.

Industry-leading integration and performance

As part of the PNX490x family, NXP's family of innovative single-chip GSM/GPRS solutions, the PNX4902 continues to provide industry-leading integration, best-in-class RF performance and power consumption, and an R99-compliant communications protocol stack that is field-tested on more than 100 networks across all major geographic markets.

The very high level of integration dramatically reduces the number of external components. The only external ICs necessary are a power amplifier and memory. A complete triband GSM/GPRS modem can be created with just 50 external components, including passives and other discretes.

A better end-user experience

Several features of NXP's highly integrated core architecture let the PNX4902 deliver a more enjoyable end-user experience. The PNX490x series is the only set of single-chip solutions that obtains such a high level of integration while maintaining best-in-class RF performance. They deliver significant margin to key GSM specs across commonly encountered stress conditions in the field, including extreme temperature and battery voltage. They maintain excellent call quality in congested, urban environments as well as in remote areas with sparse network coverage. Additional features, such as SAIC, boost network capacity even further. Superior echo cancellation and excellent noise suppression make every call clearer, even in public spaces and other noisy environments.

Plus, industry-leading power consumption means the battery lasts longer, so consumers can spend more time talking between battery recharges. With a small, inexpensive 600-mAh battery, five hours of talk time and over 420 hours of standby time are possible.

For the fastest possible time-to-market, the PNX4902 hardware reference design is accompanied by a flexible, pre-integrated, and fully validated software solution that also reduces R&D expenses.

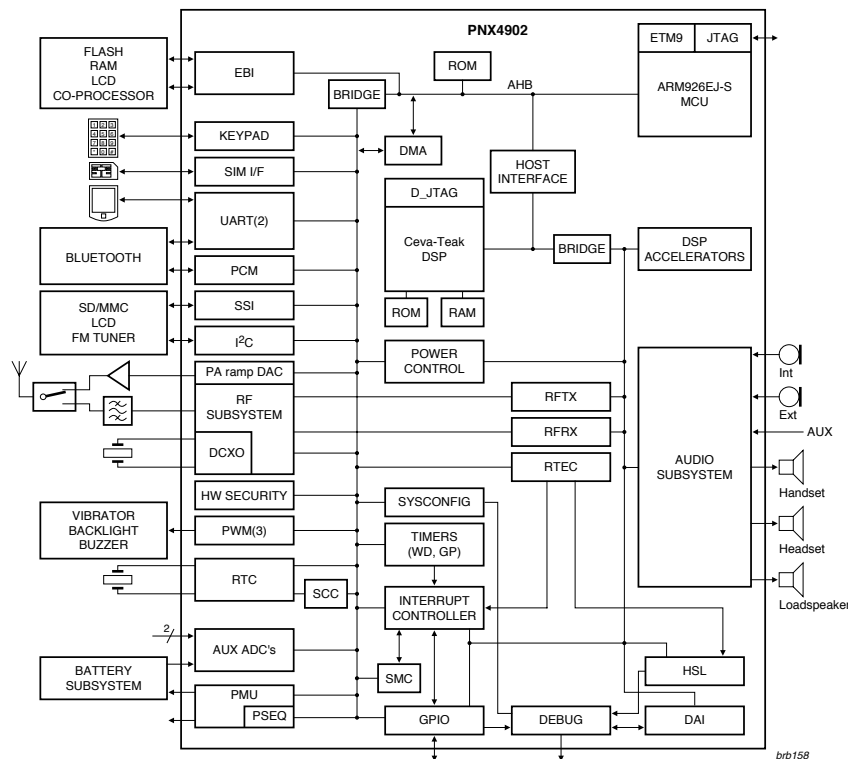

PNX4902 block diagram

www.nxp.com

founded by

PHILIPS

© 2008 NXP B.V.

All rights reserved. Reproduction in whole or in part is prohibited without the prior written consent of the copyright owner. The information presented in this document does not form part of any quotation or contract, is believed to be accurate and reliable and may be changed without notice. No liability will be accepted by the publisher for any consequence of its use. Publication thereof does not convey nor imply any license under patent- or other industrial or intellectual property rights.

Date of release: January 2008

Document order number: 9397 750 16248

Printed in the Netherlands