

FEATURES

- **2 CHANNEL TYPE:**
(1a + 1a output)
- **DESIGNED FOR AC/DC SWITCHING LINE CHANGER**
- **SMALL PACKAGE:**
8 pin DIP
- **LOW OFFSET VOLTAGE**
- **LOW LED OPERATING CURRENT:**
 $I_F = 2 \text{ mA}$
- **SURFACE MOUNT AVAILABLE**

DESCRIPTION

PS7160-2A and PS7160L-2A are solid state relays containing GaAs LEDs on the light emitting side (input side) and MOS FETs on the output side. They are suitable for analog signal control because of their low offset and high linearity.

APPLICATIONS

- EXCHANGE EQUIPMENT
- MEASUREMENT EQUIPMENT
- FA/OA EQUIPMENT

ELECTRICAL CHARACTERISTICS (TA = 25 °C)

		PART NUMBER		PS7160-2A, PS7160L-2A		
SYMBOLS		PARAMETERS	UNITS	MIN	TYP	MAX
Diode	V _F	Forward Voltage, I _F = 10 mA	V		1.2	1.4
	I _R	Reverse Current, V _R = 5 V	μA			5.0
MOS FET	I _{LOFF}	Off-State Leakage Current, V _D = 600 V	μA		0.03	1.0
	C _{OUT}	Output Capacitance, V _D = 0 V, f = 1 MHz	pF/ch		110	
Coupled	RON1	On-State Resistance, I _F = 10 mA, I _L = 10 mA	Ω		42	50
	RON2					
	t _{ON}	Turn-on Time I _F = 10 mA, V _L = 5 V, R _L = 500 Ω, PW ≥ 10 ms	ms		0.8	1.5
	t _{OFF}	Turn-off Time I _F = 10 mA, V _L = 5 V, R _L = 500 Ω, PW ≥ 10 ms	ms		0.06	0.2
	R _{I-O}	Isolation Resistance, V _{I-O} = 1.0 kV	Ω	10 ⁹		
	C _{I-O}	Isolation Capacitance, V = 0 V, f = 1 MHz	pF/ch		1.1	

Note:

1. Test Circuit for Switching Time

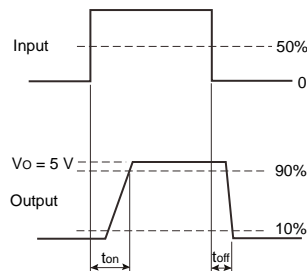
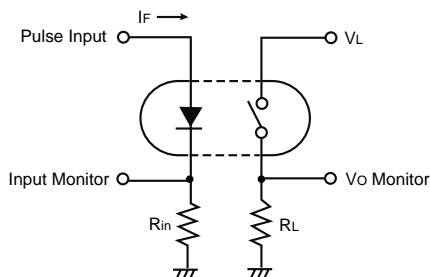

PS7160-2A, PS7160L-2A

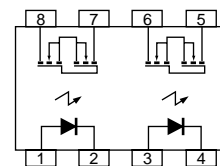

PS7160-2A, PS7160L-2A

ABSOLUTE MAXIMUM RATINGS¹ (T_A = 25°C)

SYMBOLS	PARAMETERS	UNITS	RATINGS
Diode			
I _F	Forward Current (DC)	mA	50
V _R	Reverse Voltage	V	5.0
P _D	Power Dissipation	mW/ch	50
I _{FP}	Peak Forward Current ²	A	1
MOSFET			
V _L	Break Down Voltage	V	600
I _L	Continuous Load Current	mA	90
I _{LP}	Pulse Load Current ³ (AC/DC Connection)	mA	250
P _{OUT}	Power Dissipation	mW/ch	375
Coupled			
BV	Isolation Voltage ⁴	Vr.m.s.	1500
P _T	Total Power Dissipation	mW	850
T _A	Operating Ambient Temp.	°C	-40 to +80
T _{STG}	Storage Temperature	°C	-40 to +100

Notes:

1. Operation in excess of any one of these parameters may result in permanent damage.
2. PW = 100 μs, Duty Cycle = 1 %
3. PW = 100 ms, 1 shot.
4. AC voltage for 1 minute at T_A = 25 °C, RH = 60 % between input and output.

OUTLINE DIMENSIONS (Units in mm)

PS7160-2A

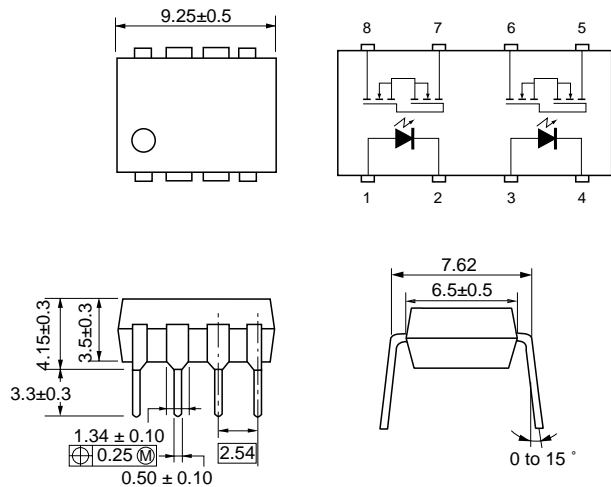

PS7160L-2A

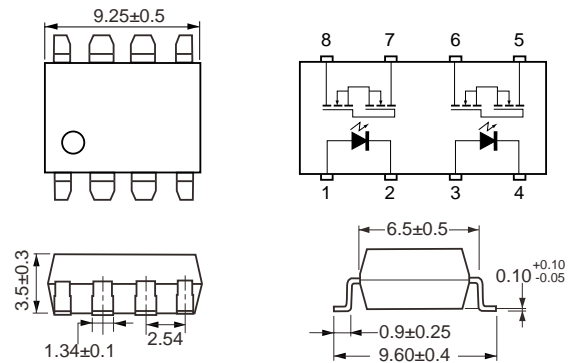

PIN CONNECTION (Top View)

PS7160-2A, PS7160L-2A

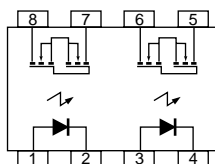

1. LED Anode 1
2. LED Cathode 1
3. LED Anode 2
4. LED Cathode 2
5. MOS FET 2
6. MOS FET 2
7. MOS FET 1
8. MOS FET 1

RECOMMENDED OPERATING CONDITIONS (T_A = 25°C)

PART NUMBER		PS7160-2A, PS7160L-2A			
SYMBOLS	PARAMETERS	UNITS	MIN	TYP	MAX
I _F	LED Operating Current	mA	2	10	20
V _F	LED Off Voltage	V	0		0.5

ORDERING INFORMATION

PART NUMBER	PACKAGE	PACKING STYLE
PS7160-2A	8 pin DIP	Magazine cae 50 pcs
PS7160L-2A		
PS7160L-2A-E3		
PS7160L-2A-E4		Embossed Tape 1000 pcs/reel

TYPICAL PERFORMANCE CURVES ($T_A = 25\text{ }^\circ\text{C}$)

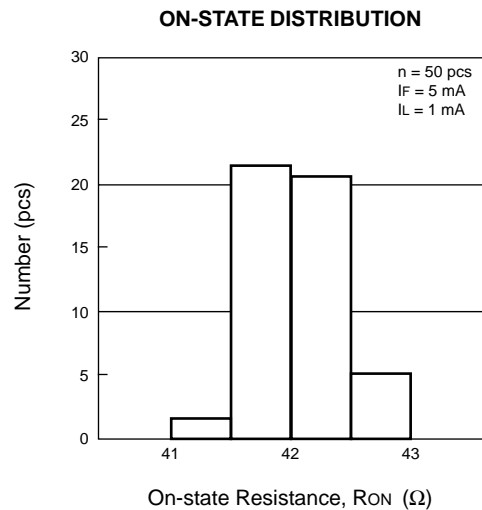
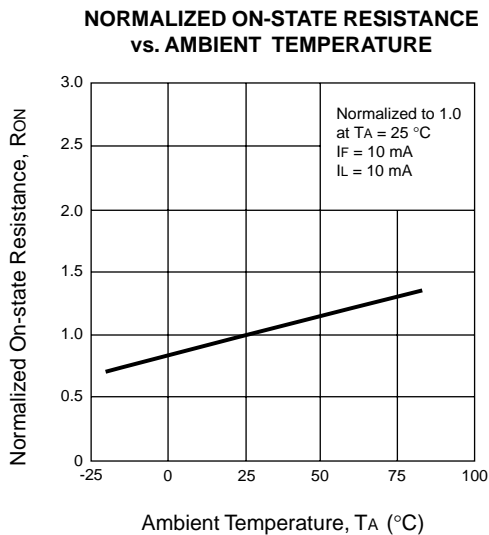
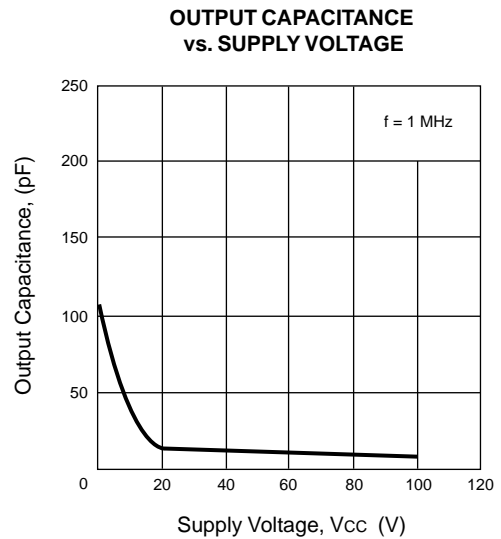
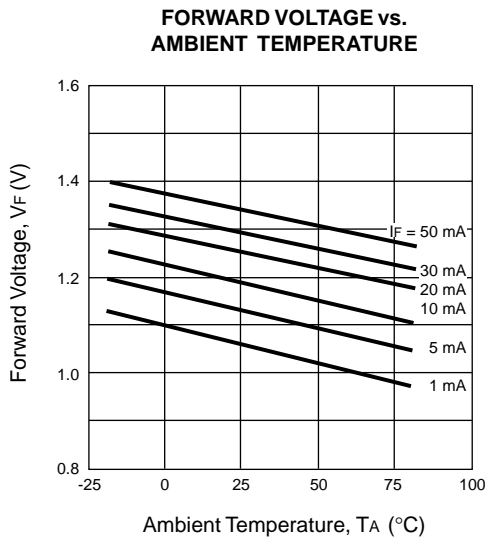
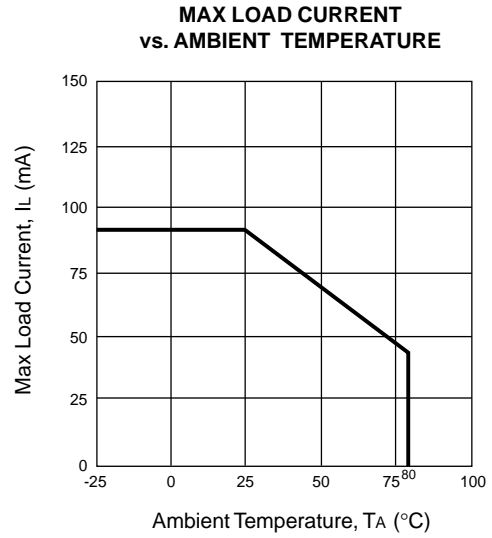
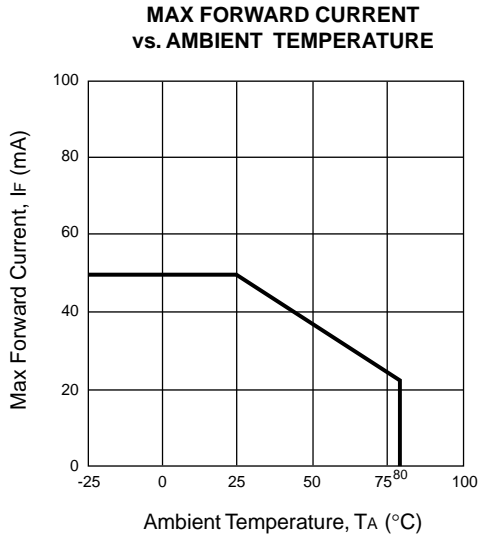

TYPICAL PERFORMANCE CURVES (TA = 25 °C)

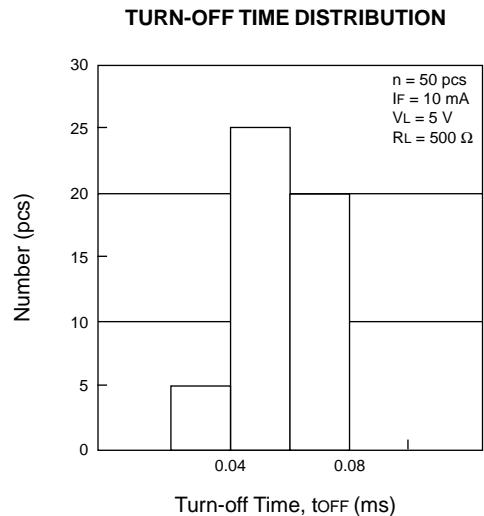
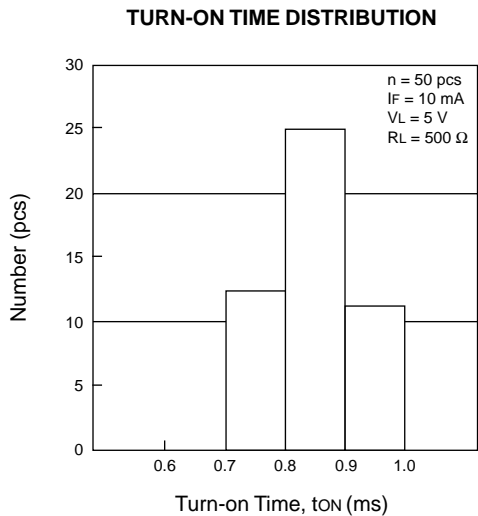
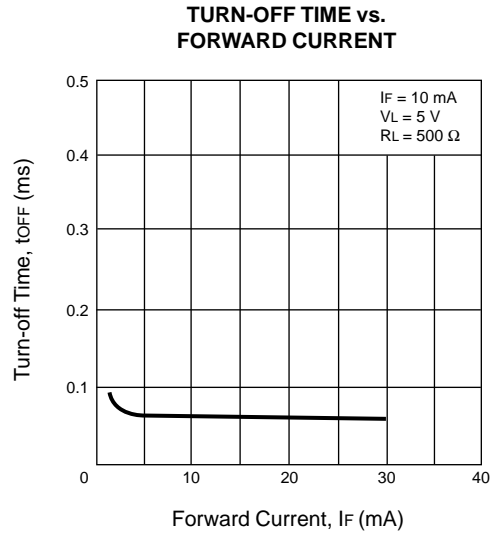
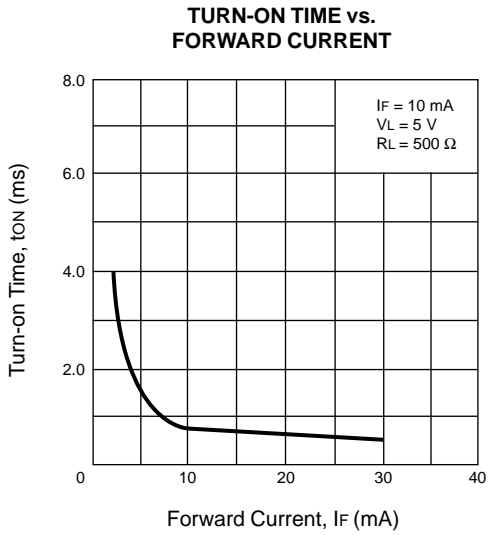
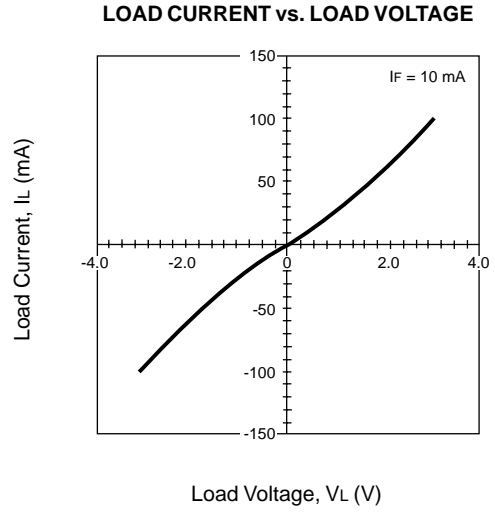
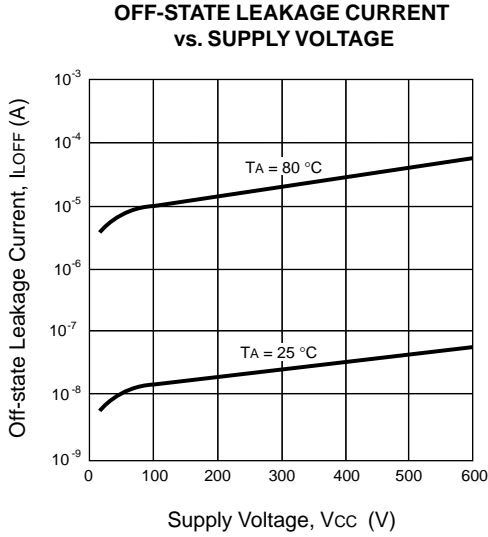

TYPICAL PERFORMANCE CURVES ($T_A = 25\text{ }^\circ\text{C}$)

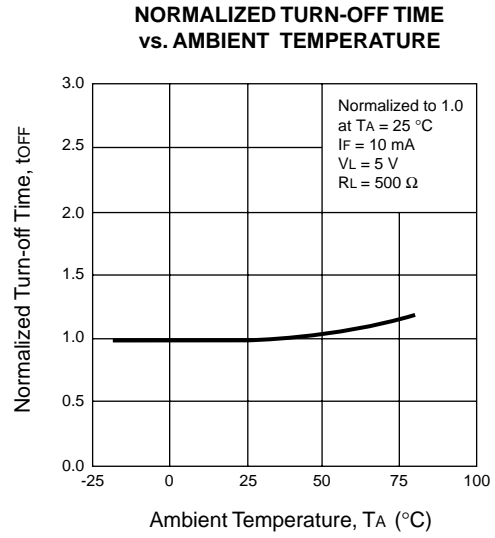
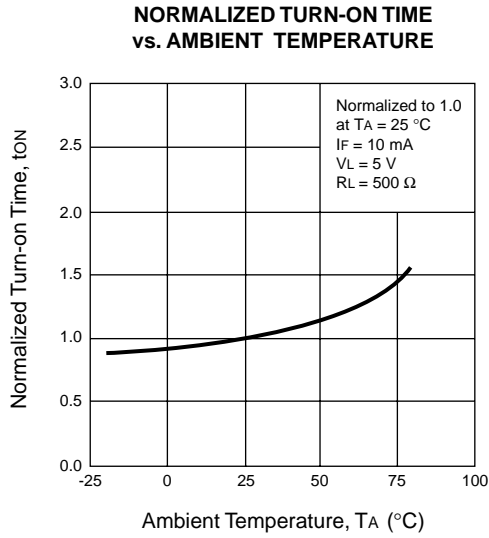

TAPING SPECIFICATIONS (Units in mm)

OUTLINE AND DIMENSIONS (TAPE)

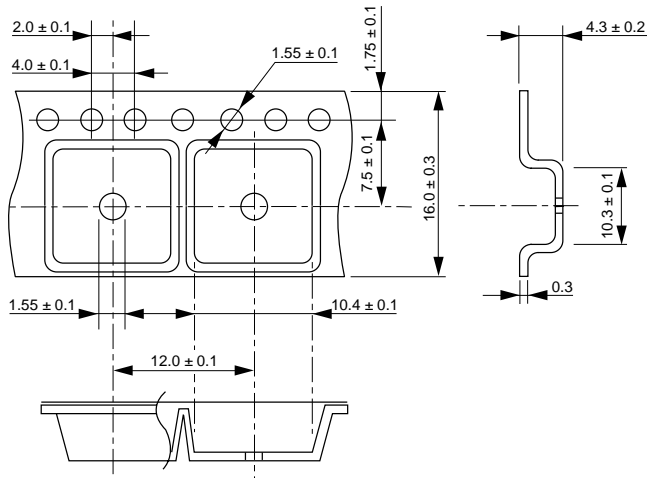

OUTLINE AND DIMENSIONS (REEL)

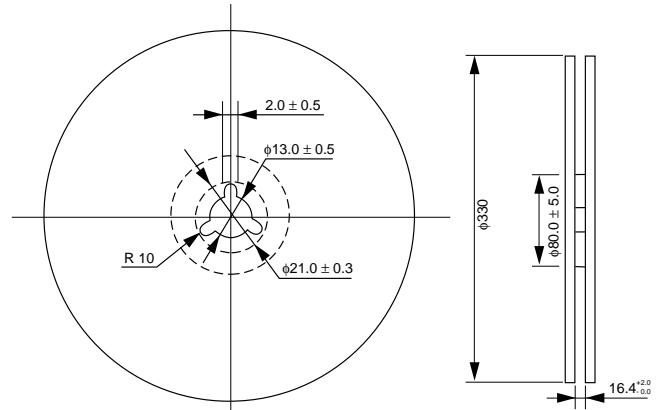

Packaging : 1000 pcs/reel

TAPING DIRECTION

PS7160L-2A-E3

PS7160L-2A-E4

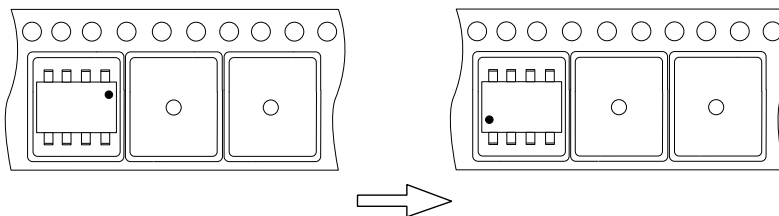

RECOMMENDED SOLDERING CONDITIONS

(1) Infrared reflow soldering

- Peak reflow temperature 235 °C or below (package surface temperature)
- Time of temperature higher than 210 °C 30 seconds or less
- Number of reflows Two
- Flux Rosin flux containing small amount of chlorine
(The flux with a maximum chlorine content of 0.2 Wt % is recommended.)

Recommended Temperature Profile of Infrared Reflow

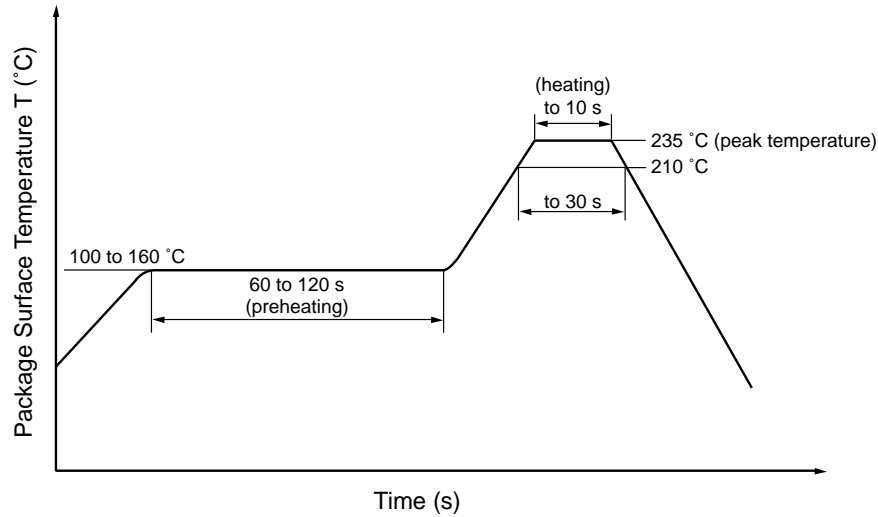

(2) Dip soldering

- Temperature 260 °C or below (molten solder temperature)
- Time 10 seconds or less
- Number of times One
- Flux Rosin flux containing small amount of chlorine
(The flux with a maximum chlorine content of 0.2 Wt % is recommended.)

(3) Cautions

- Fluxes
Avoid removing the residual flux with freon-based cleaning solvent.

EXCLUSIVE NORTH AMERICAN AGENT FOR **NEC** RF, MICROWAVE & OPTOELECTRONIC SEMICONDUCTORS

CEL CALIFORNIA EASTERN LABORATORIES • Headquarters • 4590 Patrick Henry Drive • Santa Clara, CA 95054-1817 • (408) 988-3500 • Telex 34-6393 • FAX (408) 988-0279
24-Hour Fax-On-Demand: 800-390-3232 (U.S. and Canada only) • Internet: <http://WWW.CEL.COM>