



PINGWEI ENTERPRISE

PS860L

8.0AMPS. SCHOTTKY BARRIER RECTIFIERS

FEATURE

- . For surface mounted application
- . High current capability
- . Low forward voltage drop
- . Low power loss, high efficiency
- . High surge current capability
- . High temperature soldering guaranteed: 260°C /10 seconds at terminals.

MECHANICAL DATA

- . Terminal: Solder plated
- . Case: Molded with UL-94 Class V-0 recognized Flame Retardant Epoxy

PS-277B

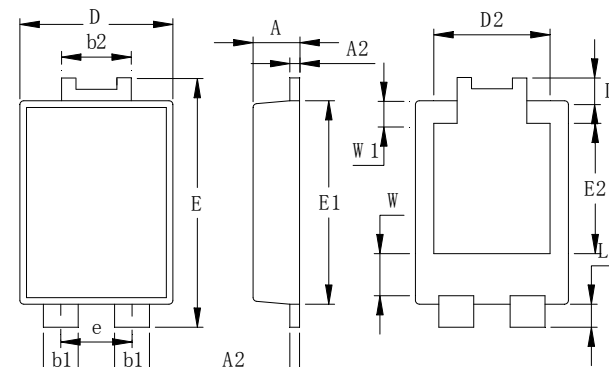

NO	Dimensions	NO	Dimensions
A	1.20±0.1	e	1.84Typ
A2	0.25±0.05	E1	5.3±0.1
b1	0.9±0.1	E2	3.3±0.2
b2	1.8±0.1	L	0.6±0.1
D	3.95±0.1	L1	0.6±0.1
D2	3.00Typ	W	1.3±0.2
E	6.5±0.1	W1	0.8±0.15

All Dimensions in mm



MAXIMUM RATINGS AND ELECTRICAL CHARACTERISTICS

Ratings at 25°C ambient temperature unless otherwise specified.

Single phase, half wave, 60Hz, resistive or inductive load. For capacitive load, derate current by 20%

Type Number	SYMBOL	PS860L	units
Maximum Recurrent Peak Reverse Voltage	V_{RRM}	60	V
Maximum RMS Voltage	V_{RMS}	48	V
Maximum DC blocking Voltage	V_{DC}	60	V
Average Forward Rectified Output Current	$I_{F(AV)}$	8.0	A
Peak Forward Surge Current 8.3ms single half sine-wave superimposed on rated load (JEDEC method)	I_{FSM}	175.0	A
Maximum Instantaneous Forward Voltage at 2.0A DC	V_F	@T _A =25°C	V
		@T _A =100°C	
Maximum Instantaneous Forward Voltage at 8.0A DC		@T _A =25°C	
		@T _A =100°C	
Maximum DC Reverse Current at rated DC blocking voltage	I_R	@T _A =25°C	mA
		@T _A =100°C	
Typical Junction Capacitance (Note1)	C_J	600	pF
Typical Thermal Resistance (Note2)	$R_{(JA)}$	45	°C/W
Storage Temperature	T_{STG}	-55 to +150	°C
Operating Junction Temperature	T_J	-55 to +150	°C

Note:

1. Measured at 1.0 MHz and applied reverse voltage of 4.0Vdc
2. Polyimide PCB, 2oz. Copper. Cathode pad dimensions 18.8mm x 14.4mm. Anode pad dimensions 5.6mm x 14.4mm.