

4

3

2

1

THERMOCOUPLE CONTACT IDENTIFICATION (WHERE APPLICABLE)	
MATERIAL	IDENTIFICATION
CHROMEL	WHITE
ALUMEL	GREEN
IRON	BLACK
CONSTANTAN	YELLOW

ACCESSORIES  
(NOT PART OF STANDARD ASSEMBLY)  
SEE DRAWING  
10-150000

35508-147		REVISIONS		
ZONE	LTR	DESCRIPTION	DATE	APPROVED
	A9	REDRAWN, SAME SIZE, PROVIDED MFG DATA, STANDARDIZED ECN: 56844-1	10-4-74 A. STARK	<i>[Signature]</i>
	B	(CL II) SEE CHG NOTICE ECN: 25770	10/28/91 melligott	<i>[Signature]</i>
	C	(CL II) ADDED TO POS. 4 IN PARTS LIST BLOCK ECN: 98906	12-2-06 JONES	

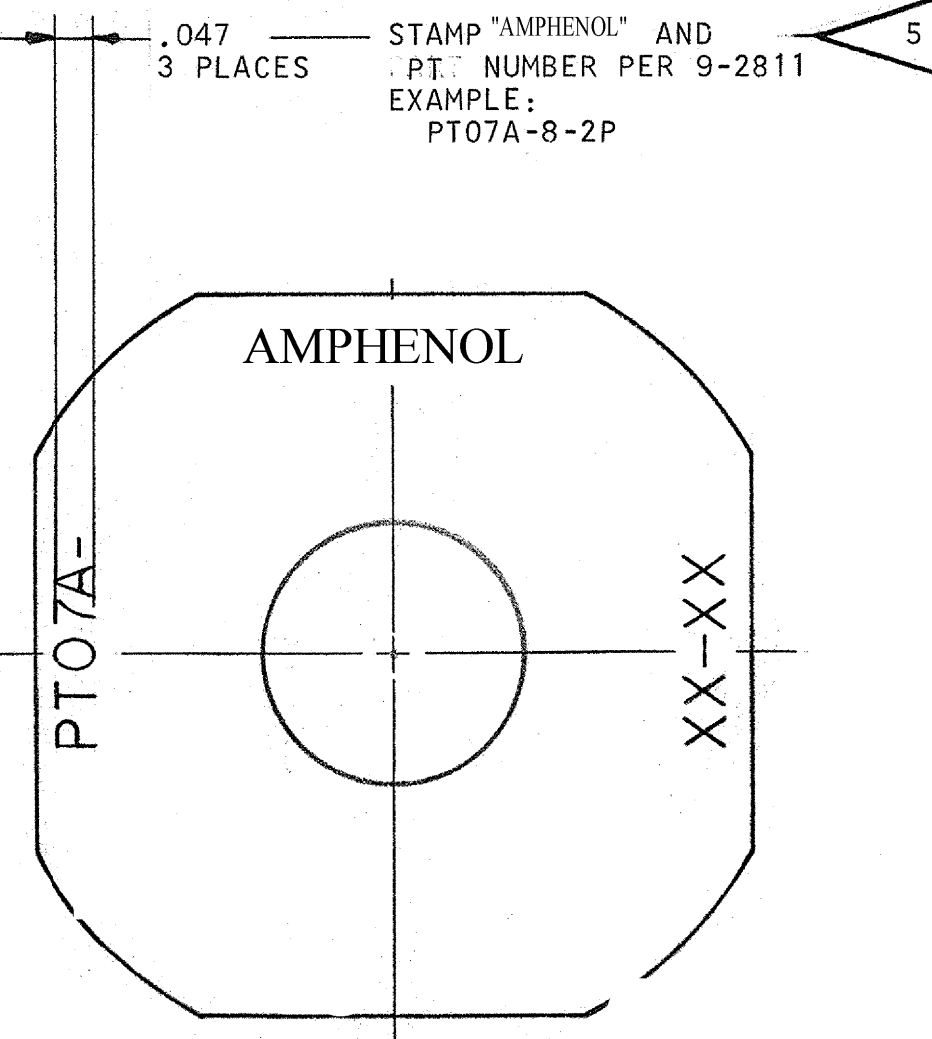
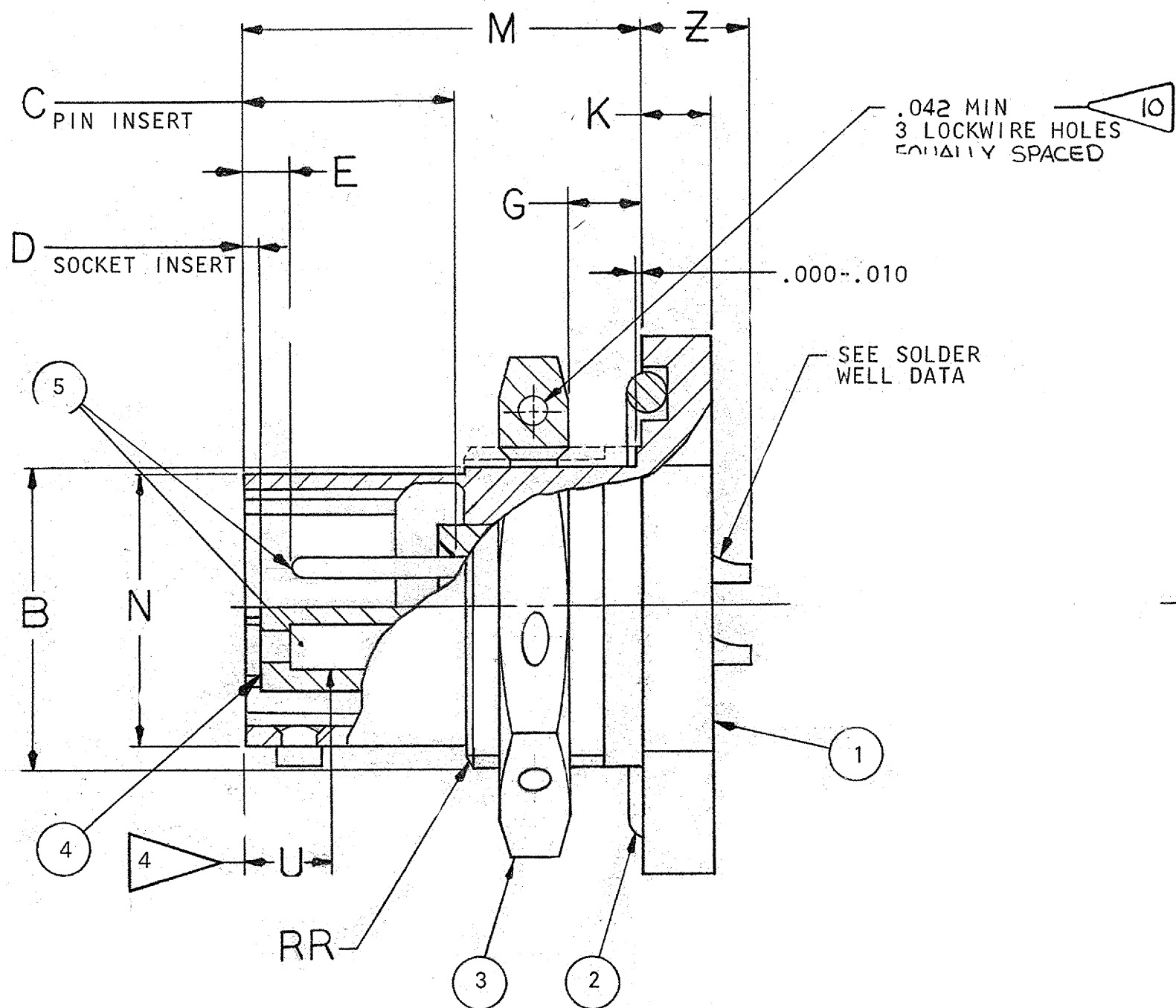
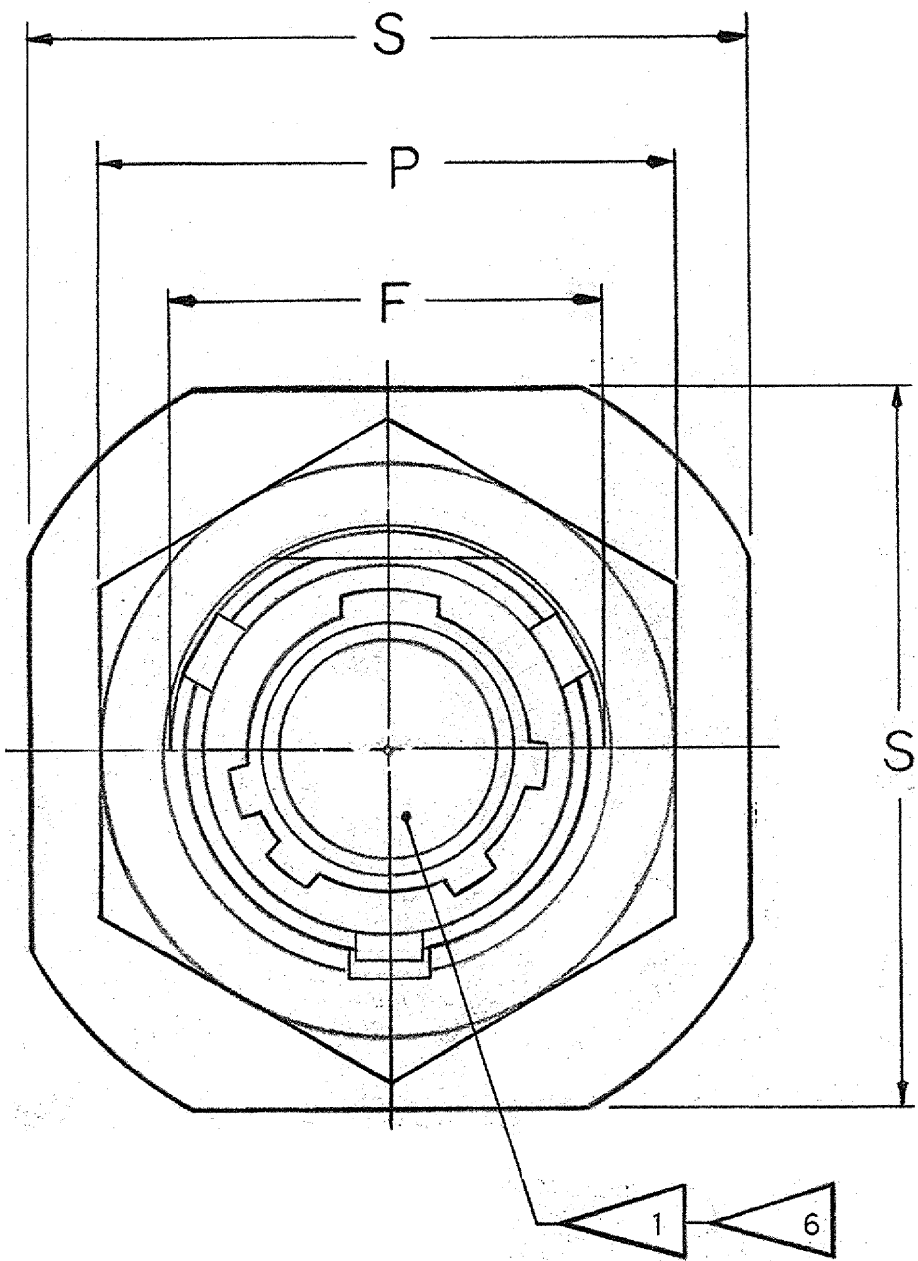

FIND NO.	QTY REQD	CODE IDENT	PART NUMBER	DESCRIPTION	NOTE REF
5		SEE NOTE 8		CONTACTS	6
			10-101806/50-( )P OR 10-252806/824-( )P OR 10-101806/50-( )S OR 10-252806/824-( )S	INSERT, PIN	6
4	1			INSERT, SOCKET	
3	1		10-123017-XX3	NUT	
2	1		SEE COLUMN	PACKING	9
1	1		10-150903-XX3	SHELL	

UNLESS OTHERWISE SPECIFIED		SIGNATURES		DATES	
LINEAR DIMENSIONS ARE IN INCHES. TOLERANCES: .XXX ± .010, .XX ± .03, .X ± .1, ANGLES ± 2°. OTHER STANDARDS PER 9-3800 AND MIL-D-1000. NOTE REF		PREPARED	SCALONE	1-11-57	
		CHECKED	<i>[Signature]</i>	5-29-75	
		MATERIAL			
MATERIAL SPEC	PROCESS SPEC	APPROVED	<i>[Signature]</i>	10/9/74	
	TEST	APPROVED	<i>[Signature]</i>	5/22/75	
	9-3980-2				
	ASSY				
	9-3443-1				
	-----				
	9-2811				
	9-2437-1				

The Bendix Corporation Electrical Components Division Sidney, New York					
TITLE: CONNECTOR, ELECTRICAL RECEPTACLE, TYPE PTJ( )FB, OLIVE DRAB					
SIZE	CODE IDENT NO.	71-146706 THRU 71-146750			
C	77820				
SCALE	WT	REF	SHEET 1 OF 2		
NONE	SEE PARTS LIST				

SEE SHEET 2  
NOTES:

USE OF THIS DOCUMENT IS UNLIMITED. DOCUMENTS REFERENCED HEREON CONTAIN LIMITED RIGHTS DATA.

NEXT ASSEMBLY

4

3

2

1

ASSEMBLY NUMBER	PT NUMBER	PACKING	B	C	D	E	F	G		K	M	N	P	S	U	Z	RR
			+ .000 - .010	+ .010 - .025	+ .010 - .025	+ .010 - .020	DIA + .000 - .016	PANEL THK MIN MAX	+ .011 - .010	DIA + .001 - .005	HEX ± .016	MAX	MAX	THREAD (PLATED) CLASS 2A			
71-146706-()	07A- 6-()	10-90351-15	.405	.337	.025	.085	.439	.062	.125	.125	.696	.348	.625	.812	.153	.231	.4375-28 UNEF
71-146708-()	- 8-()	-17	.530				.563					.473	.750	.938			.5625-24
71-146710-()	-10-()	-19	.655				.680					.590	.875	1.062			.6875-24
71-146712-()	-12-()	-22	.818				.859					.750	1.062	1.250			.875-20
71-146714-()	-14-()	-24	.942				.984					.875	1.188	1.375			1.000-20
71-146716-()	-16-()	-26	1.066				1.108					1.000	1.312	1.500			1.125-18
71-146718-()	-18-()	-28	1.191				1.233					1.125	1.438	1.625			1.250-18
71-146720-()	-20-()	-128	1.316	.399	.087	.147	1.358		.250	.156	.884	1.250	1.562	1.812	.215	.261	1.375-18
71-146722-()	-22-()	-130	1.441	.399	.087	.147	1.483		.250	.156	.884	1.375	1.688	1.938	.215	.261	1.500-18
71-146724-()	-24-()	-132	1.566	.399	.087	.147	1.610		.250	.156	.917	1.500	1.812	2.062	.215	.228	1.625-18
71-146725/50					NOT AVAILABLE												



SOLDER WELL DATA			
CONTACT SIZE	20	16	12
WELL DIA	.046 <sup>+ .004</sup> <sub>- .000</sub>	.078 <sup>+ .004</sup> <sub>- .002</sub>	.116 <sup>+ .004</sup> <sub>- .002</sub>
WELL DEPTH	<sup>+ .031</sup> <sub>- .000</sub>	.125	.188

10. FORMED LOCKWIRE HOLE DESIGN (G HOLES) OPTIONAL.
9. FOR MAXIMUM SEALING EFFICIENCY, APPLY LIGHT COAT OF COMPOUND MIL-S-8660 TO PACKING.
8. SEE SEPARATE PARTS LIST FOR COMPONENT PART NUMBERS AND QUANTITIES.
7. FOR MATING PLUG ASSEMBLY, SEE DRAWING 71-146606/50 AND OTHERS.
6. INSERTS AND CONTACTS MUST NOT BE REMOVED.
5. SEE WORK ORDER FOR PERMISSIBLE ADDITIONAL OR ALTERNATE STAMPING.
4. DISTANCE BETWEEN END OF SHELL AND THE POINT AT WHICH A GAGE PIN, HAVING THE SAME BASIC DIAMETER AS THE MATING CONTACT AND A SQUARE FACE, ENGAGES SOCKET CONTACT SPRING.
3. UNITS ILLUSTRATED MEET THE MATERIAL AND FINISH REQUIREMENTS OF MIL-C-26482.
2. TO COMPLETE ASSEMBLY NUMBER AND PT NUMBER, ADD APPLICABLE INSERT ARRANGEMENT SUFFIX TO BASE NUMBERS LISTED ABOVE PER 9-2437-1.
1. FOR CONTACT ARRANGEMENTS, SEE DRAWINGS L-15206-() THRU L-15250-().

NOTES:

SIZE	CODE IDENT NO.	71-146706 THRU
C	77820	71-146750

REV SYM	A	B	C									SCALE	WT	REF	SHEET	2
---------	---	---	---	--	--	--	--	--	--	--	--	-------	----	-----	-------	---

Amphenol