



4 Mode Preset Equalizer IC PRELIMINARY PT 2380

Description

PT 2380 is a pre-set equalizer IC utilizing CMOS Technology specially designed for audio equipment. It features four sound selections, namely: Classical, Pops, Rock and Normal/Flat which may be selected by the 2 control pins (SW1 and SW2).

PT 2380 has 2 built-in channels - each containing an internal operation amplifier and selectable resistors. Thus, least external components are used. By connecting only 3 capacitors to each channel, the high performance pre-set equalizing function of this IC is achieved. Pin assignments and application circuit are optimized for easy PCB layout and cost saving for audio applications. PT 2380 is housed in a 16-Pin DIP or SO Package and is suitable for stereo sound applications.

Features

- CMOS Technology
- Least External Components
- Available in 16 Pins, DIP or SO Package
- 4 Sound Effect Selections Available: Classical, Pops, Rock, and Normal/Flat
- High Operating Voltage Range: $V_{cc} = 5 \sim 15 \text{ V}$
- Two Channels in the same chip
- Can be controlled by Micro-Processor Output Pin

Applications

- Mini Compo
- Car Stereo
- Radio Cassette Recorders
- Multi-Media Speaker
- MPEG Card
- Other Audio Equipments

4-Mode Preset Equalizer IC PRELIMINARY PT 2380

Block Diagram

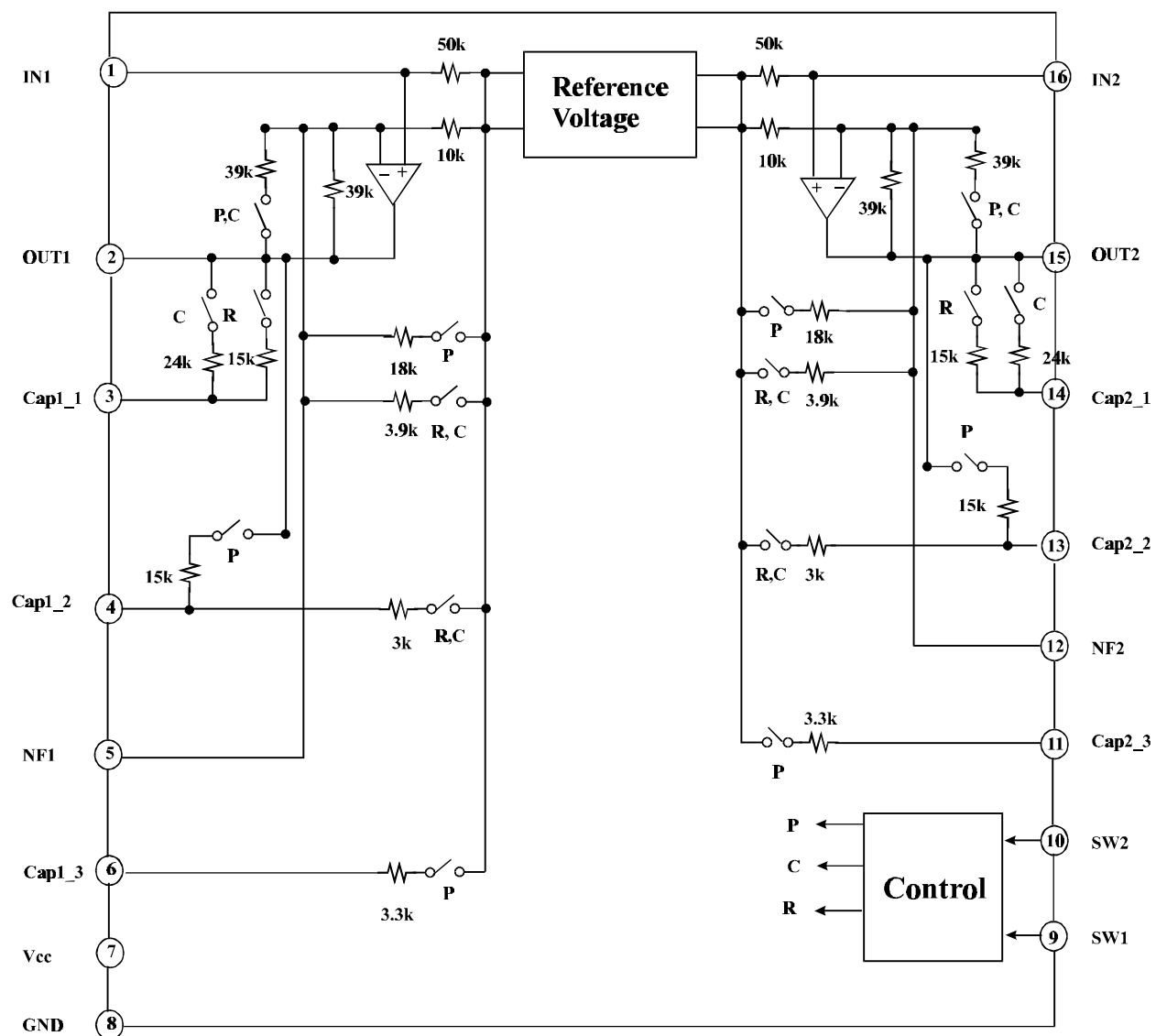

where: N = Normal/Flat Mode C = Classic Mode
 P = Pops Mode R = Rock Mode

Figure 1: PT2380 Block Diagram

4-Mode Preset Equalizer IC PRELIMINARY PT 2380

Pin Configuration

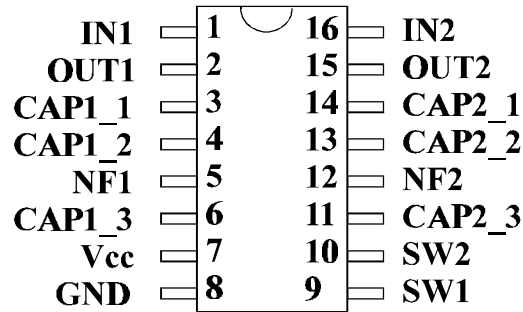

PT 2380

Figure 2: PT2380 Pin Configuration

Pin Description

Pin Name	I/O	Description	Pin No.
IN1	I	Signal Input Pin 1	1
OUT1	O	Signal Output Pin 1	2
Cap1_1	-	This pin is connected to Pin 5 by an external Capacitor	3
Cap1_2	-	This pin is connected to Pin 5 by an external Capacitor.	4
NF1	-	Feedback Node 1	5
Cap1_3	-	This pin is connected to Pin 5 by an external Capacitor.	6
Vcc	-	Positive Power Supply	7
GND	-	Ground	8
SW1	I	Mode Switch 1	9
SW2	I	Mode Switch 2	10
Cap2_3	-	This pin is connected to Pin 12 by an external Capacitor.	11
NF2	-	Feedback Node 2	12
Cap2_2	-	This pin is connected to Pin 12 by an external Capacitor.	13
Cap2_1	-	This pin is connected to Pin 12 by an external Capacitor.	14
OUT2	O	Signal Output Pin 2	15
IN2	I	Signal Input Pin 2	16

4-Mode Preset Equalizer IC PRELIMINARY PT 2380

Functional Description

PT2380 is pre-set to 4 modes: Normal/Flat, Rock, Classical and Pops. These 4 modes may be selected using two switches, namely: SW1 (Pin. No.9) and SW2 (Pin No.10). Please refer to the table below.

Mode	SW1	SW2
Normal/Flat	Low	Low
Rock	Low	High
Classic	High	Low
Pops	High	High

where Low: SW1/SW2 \leq 1V and High: SW1/SW2 \geq 3.5V for Vcc = 5 ~ 12 V

Table 1: SW1 & SW2 Mode Conditions

The Output Voltage Gain vs. the Frequency Graph for the 4 preset modes is given below:

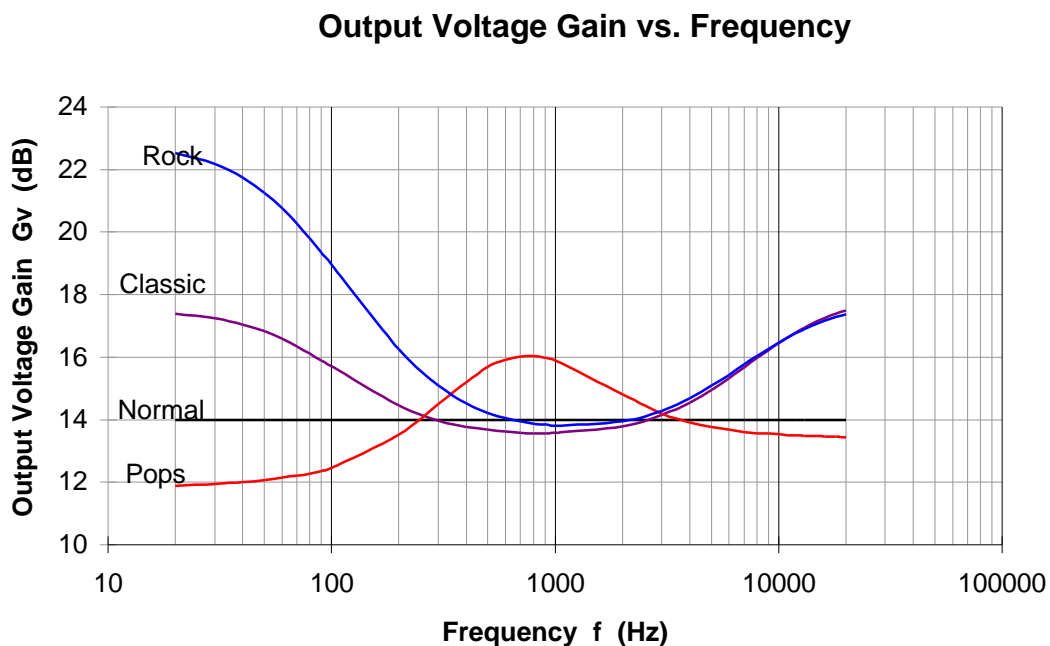

Figure 3: PT 2380 Output Voltage Gain vs. Frequency Graph

4-Mode Preset Equalizer IC PRELIMINARY PT 2380

In order to best describe this IC, an application example is hereby given. The application example's electrical characteristics are enumerated below.

Conditions: $V_{cc} = 12.0 \text{ V}$, $V_i = 0.1 \text{ V}_{rms}$ and $f = 1 \text{ KHz}$

Symbol	Parameter		Condition	Data	Unit	
Icc	Circuit Operation Current		$V_{cc}=12.0 \text{ V}$ $V_i =0.0 \text{ V}$	8.0	mA	
GBn	P	Normal Mode Voltage Gain	Bass	$f=80\text{Hz}$	14	dB
GMn	R		Mid	$f=1\text{KHz}$	14	dB
GTn	E		Treble	$f=10\text{KHz}$	14	dB
GBr	S	Rock Mode Voltage Gain	Bass	$f=80\text{Hz}$	20	dB
GMr	E		Mid	$f=1\text{KHz}$	14	dB
GTr	T		Treble	$f=10\text{KHz}$	16	dB
GBc	M	Classic Mode Voltage Gain	Bass	$f=80\text{Hz}$	16	dB
GMc			Mid	$f=1\text{KHz}$	14	dB
GTc			O	Treble	$f=10\text{KHz}$	16
GBp	D	Pops Mode Voltage Gain	Bass	$f=80\text{Hz}$	12	dB
GMp	E		Mid	$f=1\text{KHz}$	16	dB
GTP			Treble	$f=10\text{KHz}$	14	dB
VOM	Maximum Output Voltage		$f=1\text{KHz}$ $V_{cc}=5\text{V}, V_i=0.3\text{V}_{rms}$ $V_{cc}=12\text{V}, V_i=0.8\text{V}_{rms}$	1.5 4.0	V_{rms}	
THD	Total Harmonic Distortion		$\text{BW}=400\text{Hz}\sim 30\text{KHz}$ A-Weighting	0.02	%	
VNO	Output Noise Voltage		$\text{BW}=400\text{Hz}\sim 30\text{KHz}$ A-Weighting, $V_i=0.0\text{V}$	50	μV_{rms}	
Ri	Input Resistor			50	$\text{k}\Omega$	

Table 2: Application Example Electrical Characteristic Values

4-Mode Preset Equalizer IC PRELIMINARY PT 2380

The Sound Frequency Characteristics of the application example is given below.

Normal Mode Sound Frequency Characteristics

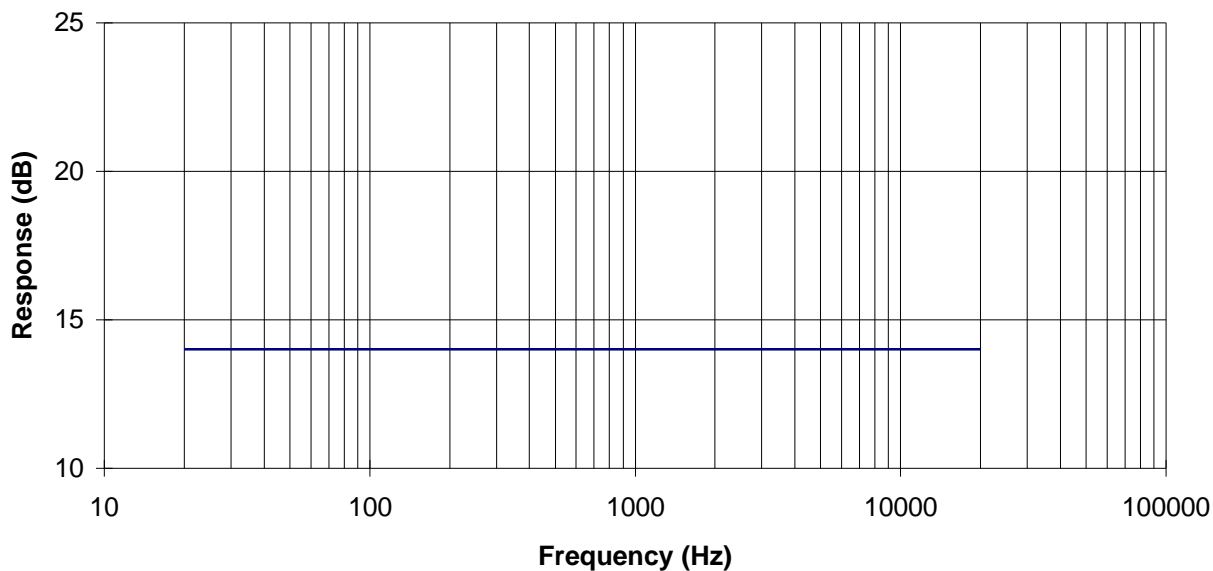

Figure 4: Normal Mode Sound Frequency Characteristics Diagram

Classic Mode Sound Frequency Characteristics

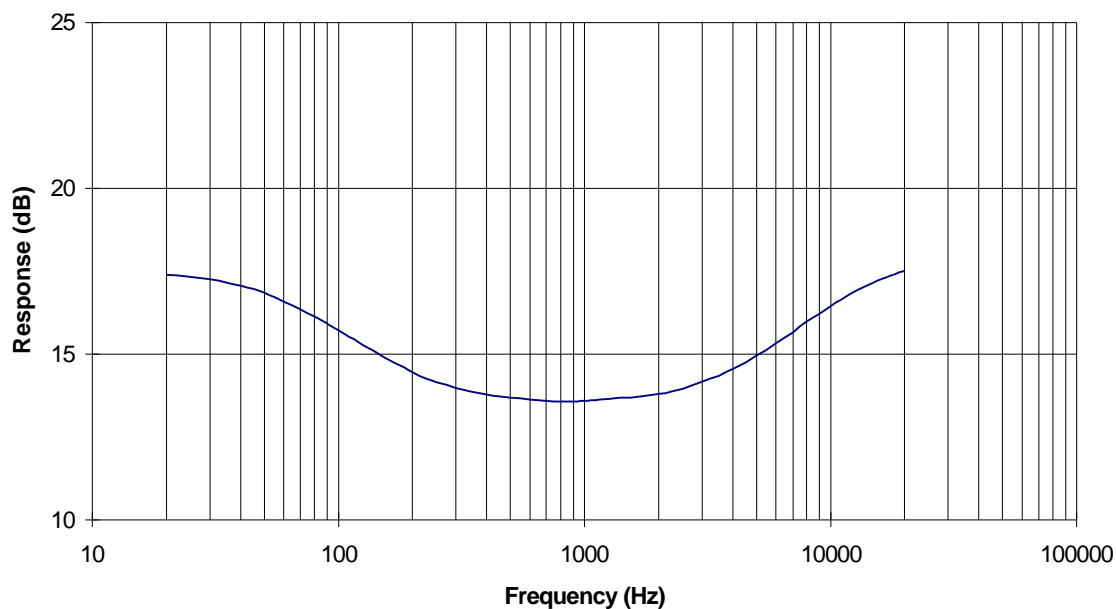

Figure 5: Classic Mode Sound Frequency Characteristics Diagram

4-Mode Preset Equalizer IC PRELIMINARY PT 2380

Pops Mode Sound Frequency Characteristics

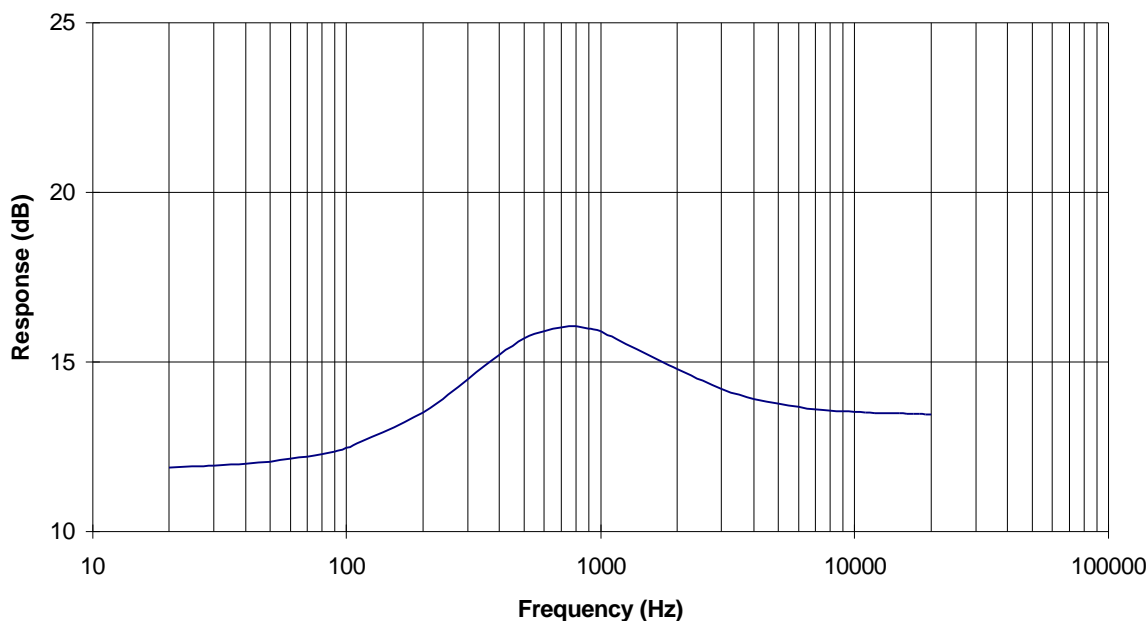

Figure 6: *Pops Mode Sound Frequency Characteristics Diagram*

Rock Mode Sound Frequency Characteristics

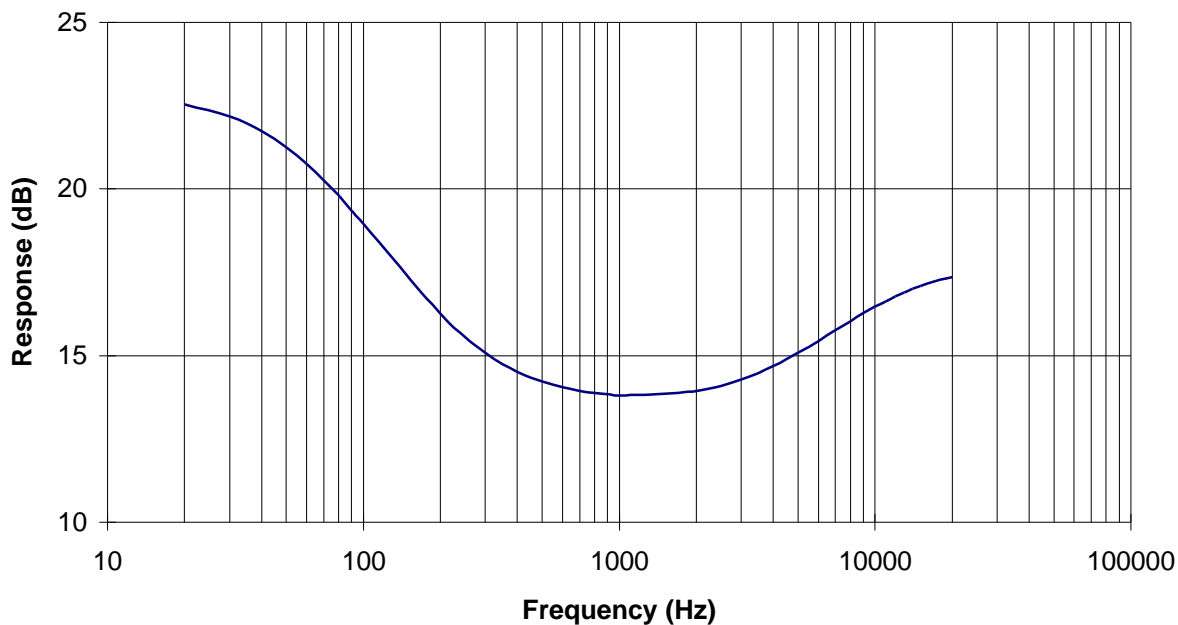

Figure 7: *Rock Mode Sound Frequency Characteristics Diagram*

4-Mode Preset Equalizer IC PRELIMINARY PT 2380

Absolute Maximum Ratings

(Unless otherwise specified, Ta=25°C)

Symbol	Parameter	Ratings	Unit
V _{cc} max	Supply Voltage	15	V
P _d	Power Dissipation (Ta ó 25°C)	1000	mW
K _o	Thermal Derating (Ta > 25°C)	10.0	mW/°C
T _{opr}	Operating Temperature	-20 ~ 75	°C
T _{stg}	Storage Temperature	-40 ~ 125	°C
V _I	Switch Input Voltage Range	-0.3 ~ V _{cc} +0.3	V

Application Circuits

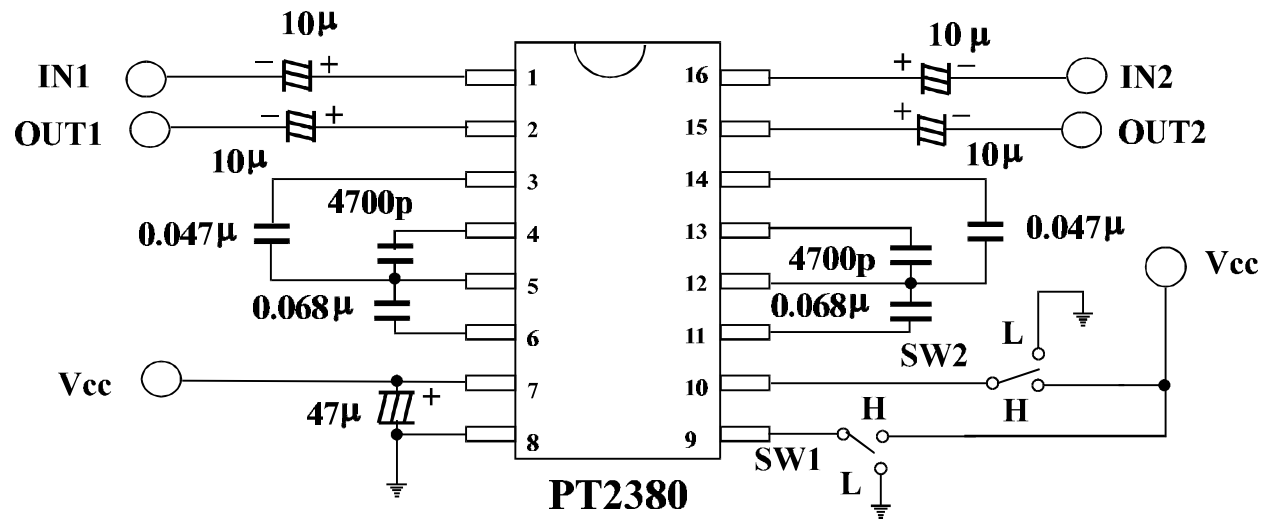

Figure 8: PT2380 Application Circuit

4-Mode Preset Equalizer IC

PRELIMINARY

PT 2380

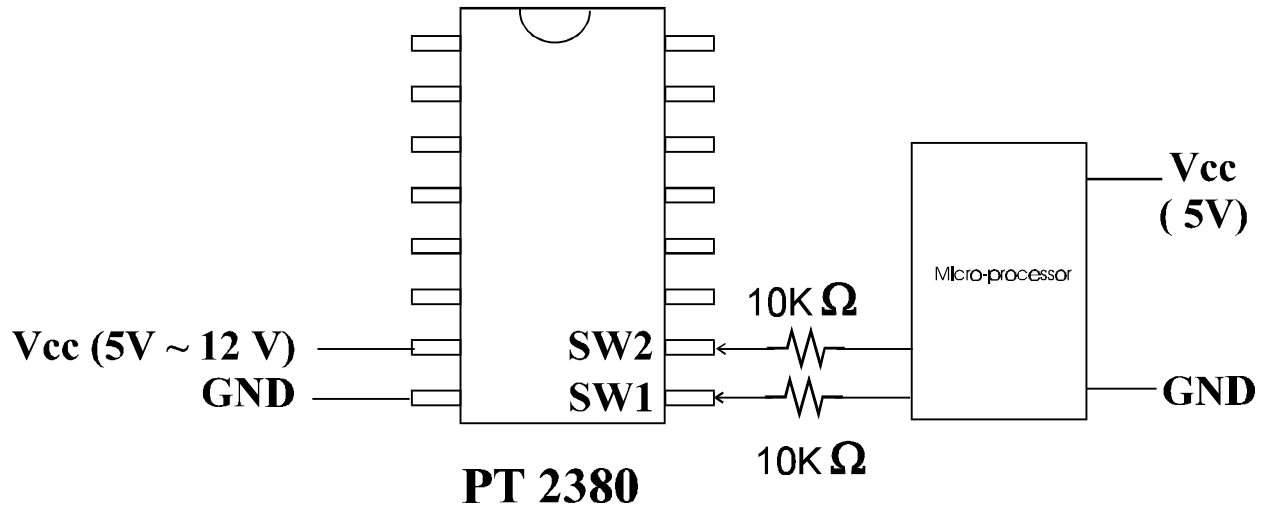
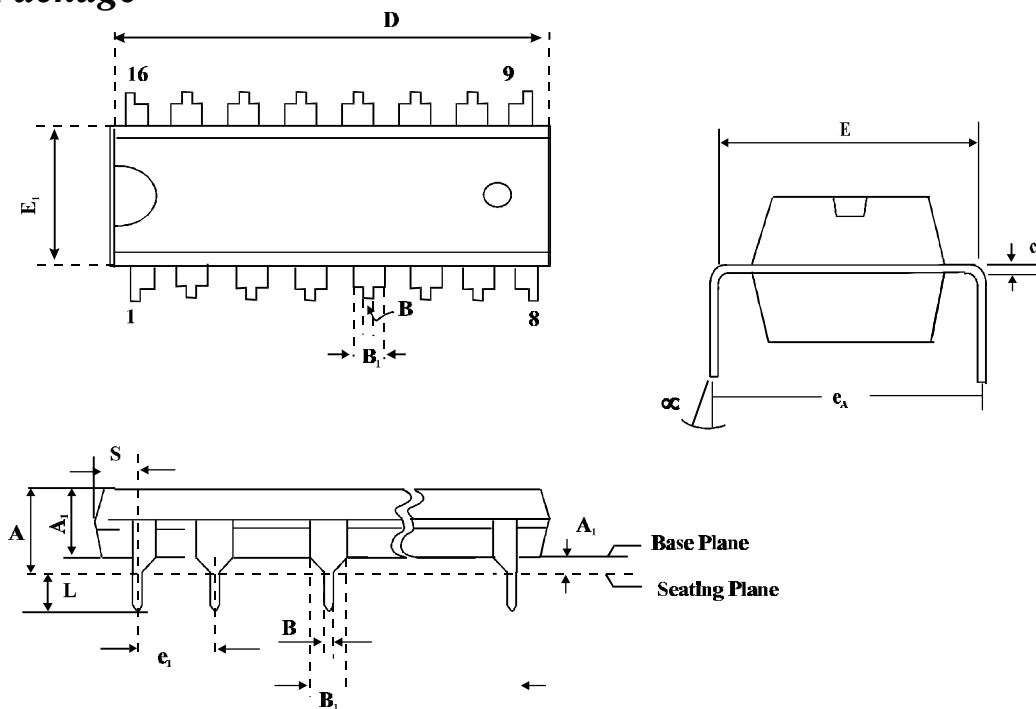

Figure 9: PT2380 Application Circuit with Micro-Processor Connection

Package Dimension

DIP Package



4-Mode Preset Equalizer IC PRELIMINARY PT 2380

Symbol	Dimensions in Inch	Dimensions in mm
A	0.175 Max	4.45 Max
A ₁	0.010 Min	0.25 Min
A ₂	0.130 + 0.005	3.30 + 0.13
B	0.018 + 0.004 0.018 - 0.002	0.46 + 0.10 0.46 - 0.05
B ₁	0.060 + 0.004 0.060 - 0.002	1.52 + 0.10 1.52 - 0.05
c	0.010 + 0.004 0.010 - 0.002	0.25 + 0.10 0.25 - 0.05
D	0.750 TYP (0.770 Max)	19.05 TYP (19.56 Max)
E	0.300 + 0.010	7.62 + 0.25
E ₁	0.250 + 0.005	6.35 + 0.13
e ₁	0.100 + 0.010	2.54 + 0.25
L	0.130 + 0.010	3.30 + 0.25
α	0° ~ 15°	0° ~ 15°
e _A	0.355 + 0.020	9.02 + 0.51
S	0.040 Max	1.02 Max

- Note:
1. The max value of dimension D includes end flash.
 2. The dimension E₁ doesn't include resin fins
 3. The dimension S includes end flash.
 4. All dimensions are based on British system

SO Package

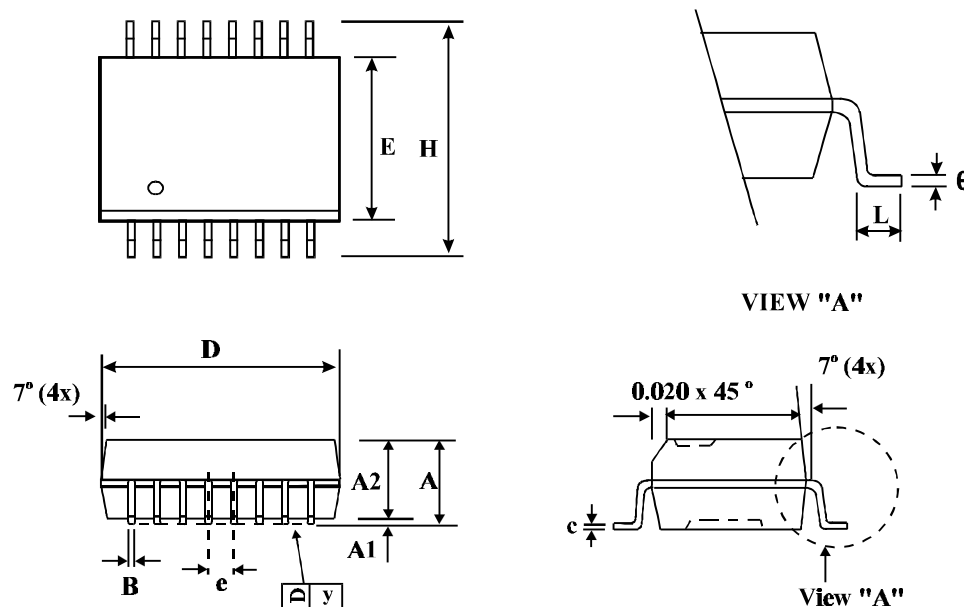

4-Mode Preset Equalizer IC PRELIMINARY PT 2380

Symbols	Dimensions in Millimeters			Dimensions in Inches		
	Min.	Nom.	Max.	Min.	Nom.	Max.
A	2.36	2.49	2.64	0.093	0.098	0.104
A1	0.10	-	0.30	0.004	-	0.012
A2	-	2.31	-	-	0.091	-
B	0.33	0.41	0.51	0.013	0.016	0.020
C	0.18	0.23	0.28	0.007	0.009	0.011
D	12.60	10.31	10.49	0.397	0.406	0.413
E	7.39	7.49	7.59	0.291	0.295	0.299
e	-	1.27	-	-	0.050	-
II	10.01	10.31	10.64	0.394	0.406	0.419
L	0.38	0.81	1.27	0.015	0.032	0.050
y	-	-	0.10	-	-	0.004
0	0°	-	8°	0°	-	8°

- Note:
1. Controlling Dimension : Inch
 2. Lead Frame Material : Copper 194
 3. After solder plating lead thickness will be 0.013” max.
 4. Dimension “D” does not include mold flash, protrusions or gate burrs.
 5. Dimension “E” does not include interlead flash or protrusions.
 6. Tolerance : ± 0.010” unless otherwise specified.
 7. Otherwise dimensions follow acceptable spec.

Ordering Information

Valid Part Number	Package Description
PT2380	16 Pins, DIP
PT2380 S	16 Pins, SO

