

DESCRIPTION

PT6526 is a General Purpose LCD Driver IC utilizing CMOS Technology specially designed for electronic tuners controlled by microcontroller. It can drive up to a maximum of 204 segment outputs and can control up to 12 general purpose output ports. Pin assignments and application circuit are optimized for easy PCB layout and cost saving advantages.

APPLICATION

- Frequency Display for Electronic Tuners

FEATURES

- CMOS Technology
- Up to 4 Common and 51 Segment Drivers
- Up to 204 LCD Segments
- Up to 12 General Purpose Output Ports
- 1/4 Duty – 1/2 Bias or 1/4 Duty – 1/3 Bias Drive Technique
- No Decoder Intervention Necessary to Display the Data
- Power Saving Mode provided
- Power Supply Voltage: 4.5V to 6V
- CMOS/TTL compatible logic input pins
- RC Oscillation Circuit
- Available in 64 pins, LQFP

BLOCK DIAGRAM

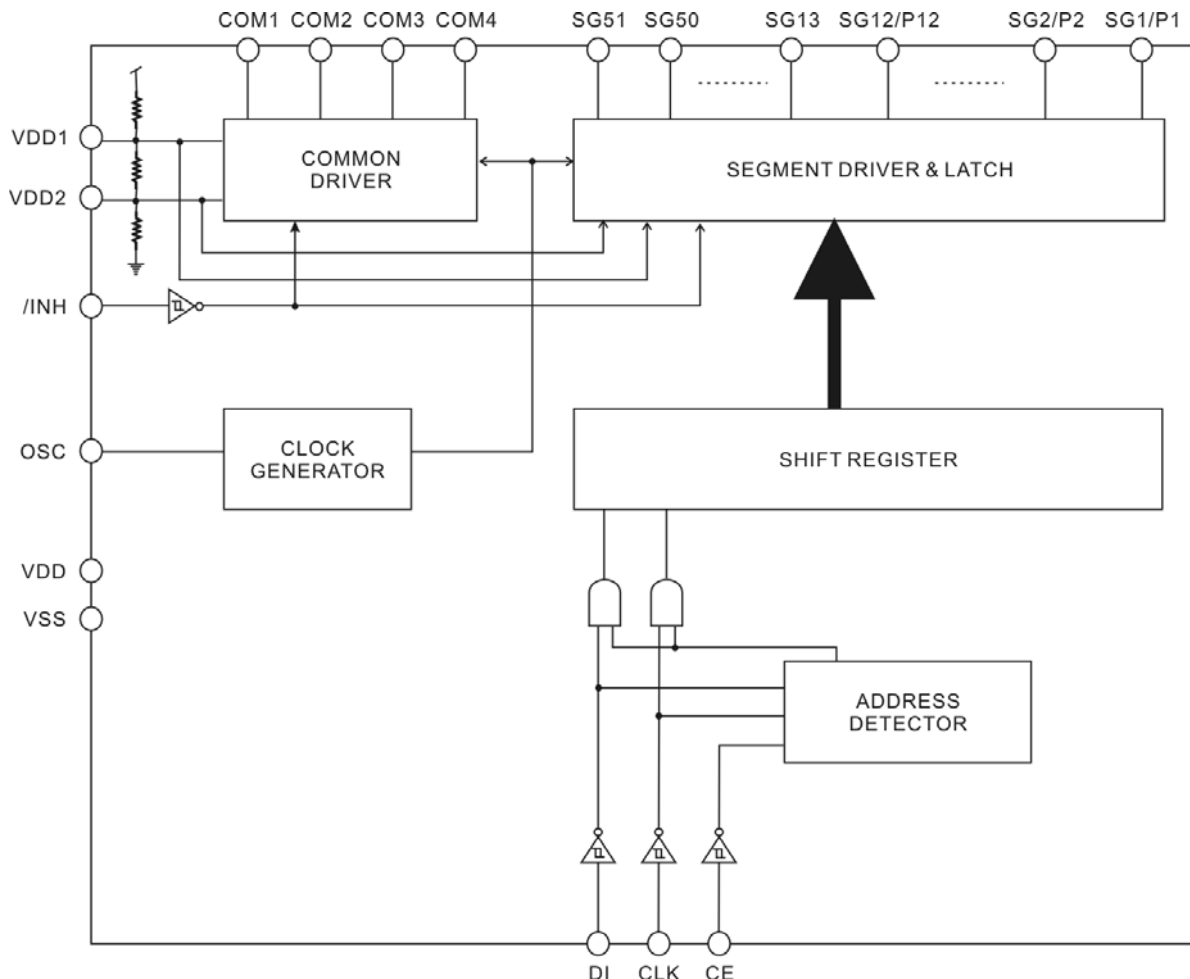

1/2 BIAS (LARGE PANELS)

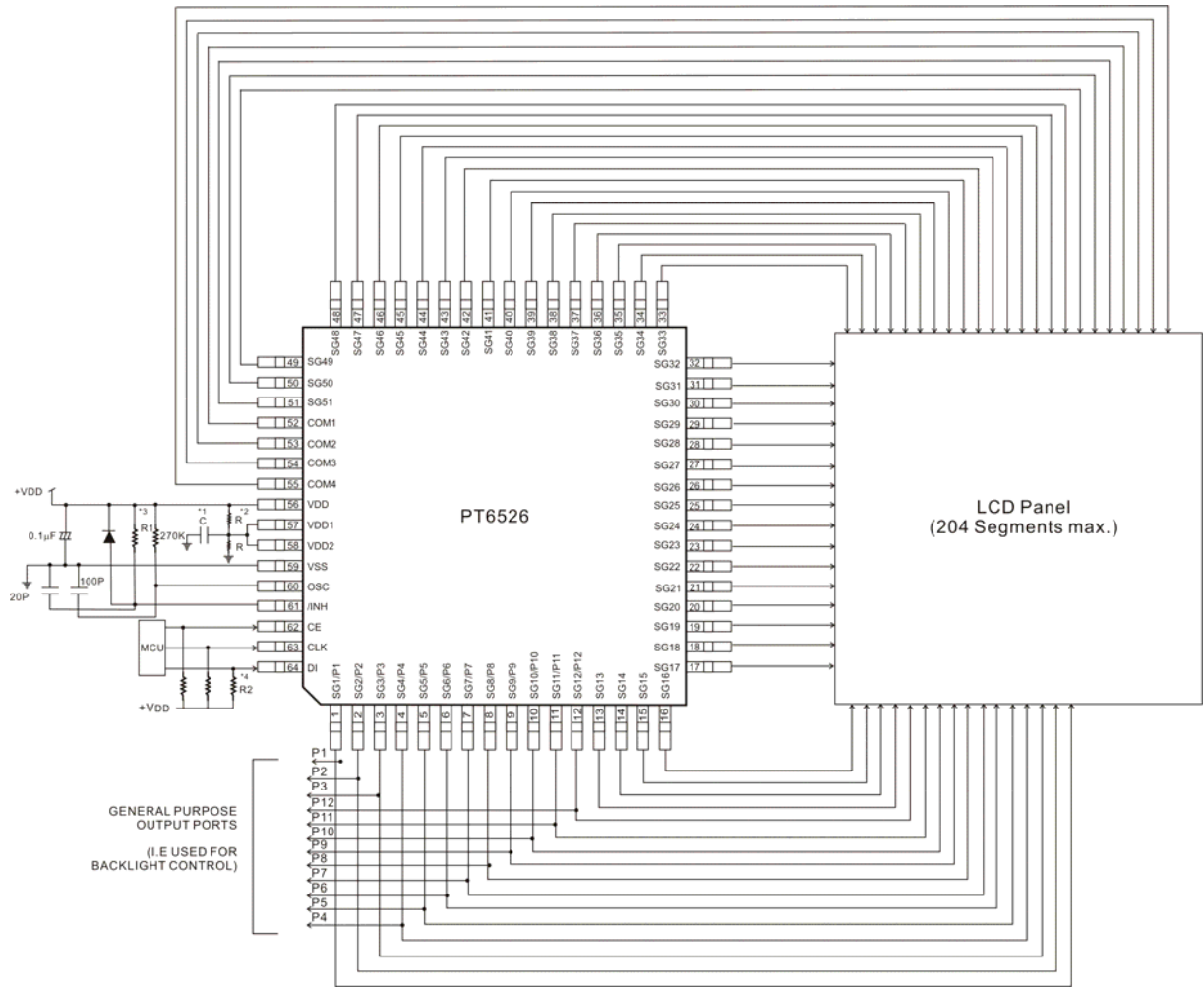

Notes:

1. $C \geq 0.047\mu\text{F}$
2. $10\text{K}\Omega \geq R \geq 1\text{K}\Omega$
3. $39\text{K}\Omega \geq R1 \geq 1\text{K}\Omega$

1/3 BIAS (LARGE PANELS)

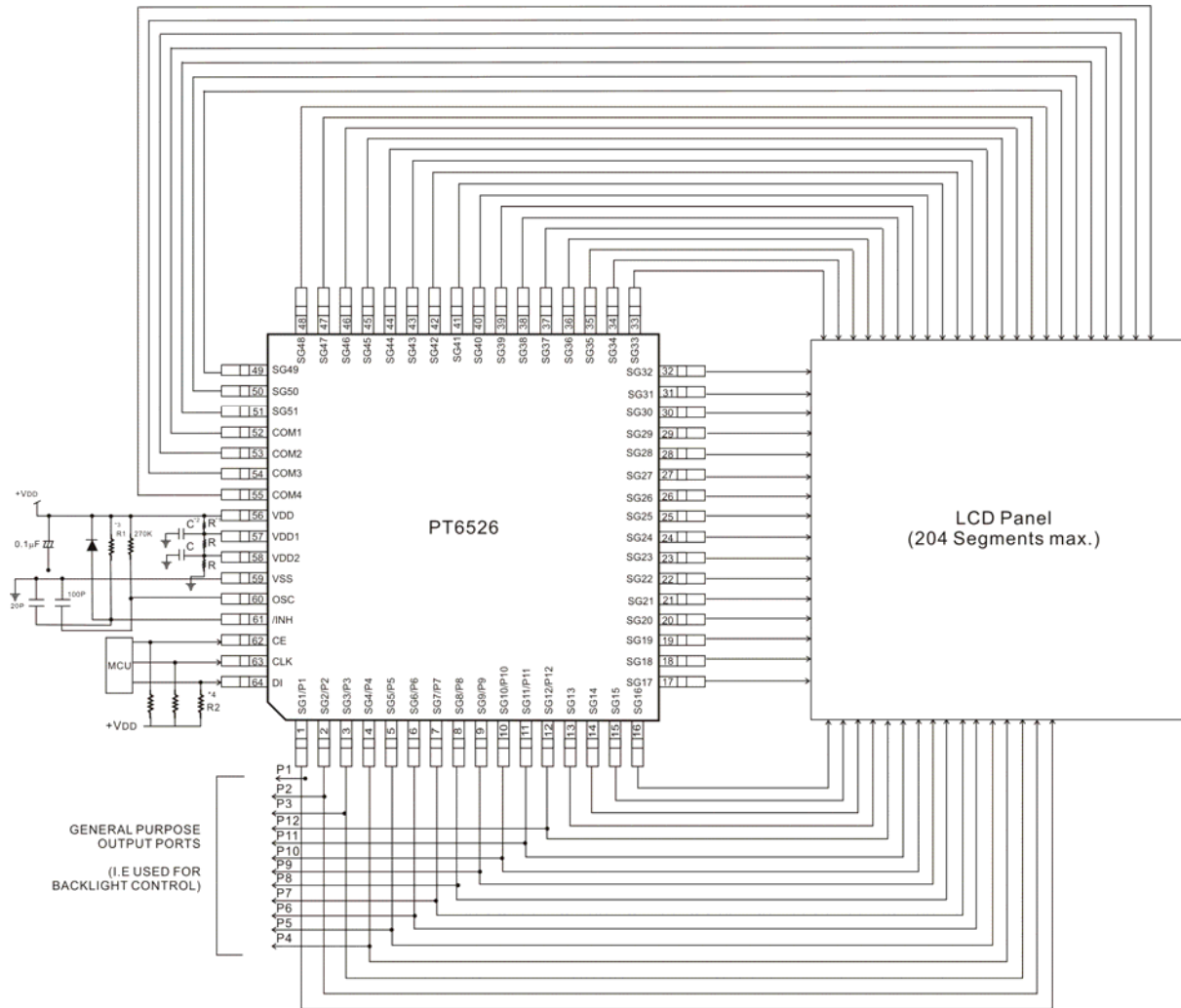

- Notes:
1. $10K\Omega \geq R \geq 1K\Omega$
 2. $C \geq 0.047\mu F$
 3. $39K\Omega \geq R1 \geq 1K\Omega$

ORDER INFORMATION

Valid Part Number	Package Type	Top Code
PT6526-LQ	64 Pin, LQFP	PT6526-LQ

PIN CONFIGURATION

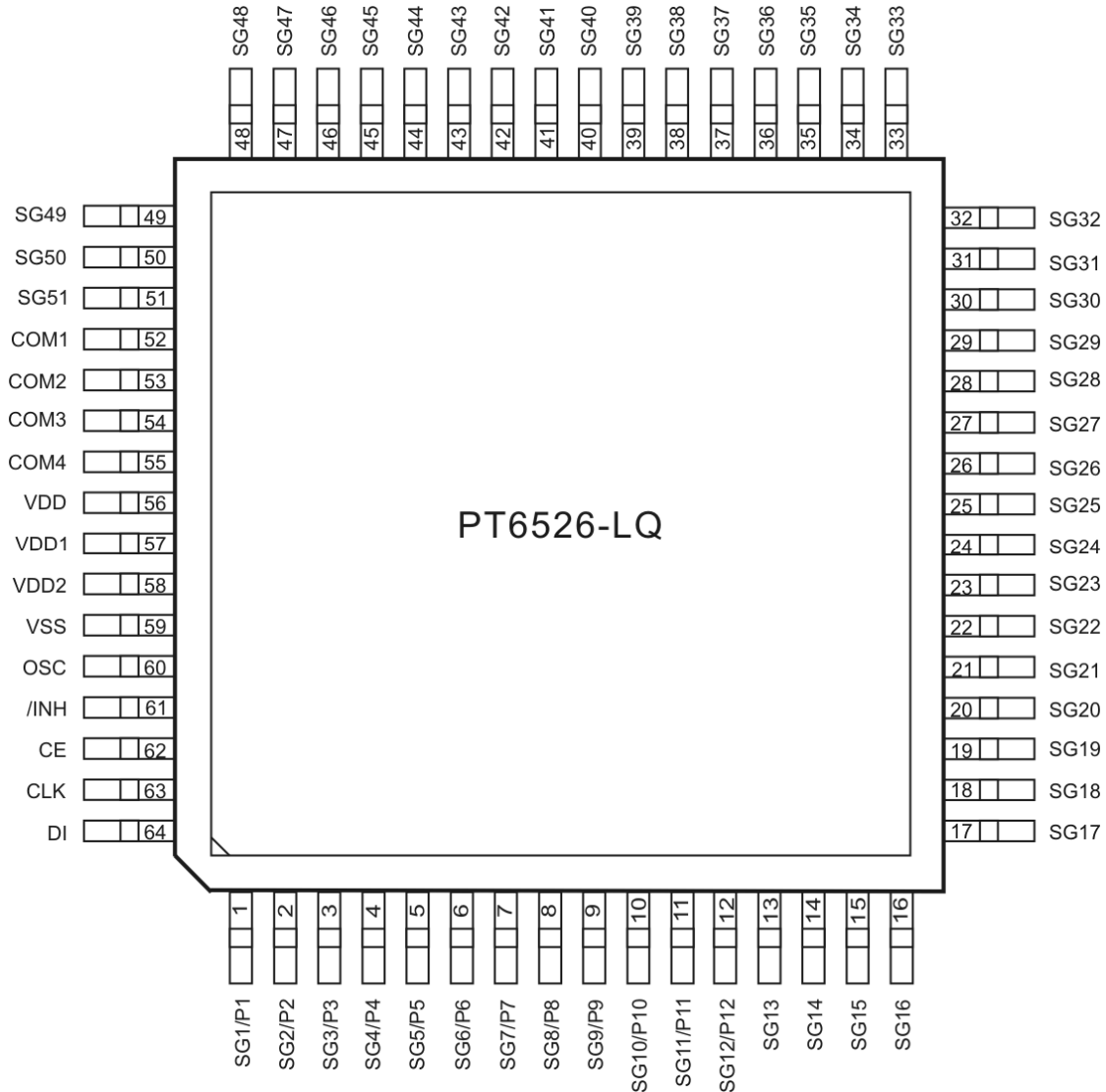

PIN DESCRIPTION

Pin Name	I/O	Description	Pin No.
SG1/P1 ~ SG12/P12	O	Segment Driver Output/General Purpose Output Ports	1 ~ 12
SG13 ~ SG51	O	Segment Driver Output Pins	13 ~ 51
COM1 ~ COM4	O	Common Driver Output Pins	52 ~55
VDD	-	Power Supply	56
VDD1	-	Power Supply This pin is used to apply a 2/3 LCD Drive Bias Voltage. If the 1/2 Bias Drive Technique is used, this pin must be short to VDD2.	57
VDD2	-	Power Supply This pin is used to apply a 1/3 LCD Drive Bias Voltage. If the 1/2 Bias Drive Technique is used, this pin must be short to VDD1.	58
VSS	-	Ground	59
OSC	I/O	Oscillation Input / Output Pin	60
/INH	I	Display OFF Control Pin If this pin is set to "LOW" (VSS), the display is forced to turn OFF. Output driver pins -- SG1/P1 to SG12/P12, SG13 to SG51, COM1 to COM4 are set to "LOW". If this pin is set to "HIGH" (VDD), the display is turned ON. (see Note)	61
CE	I	Chip Enable Pin	62
CLK	I	Clock Input Pin	63
DI	I	Data Input Pin	64

Note: It must be noted that when the display is forcibly turned OFF, the serial data transfers can still be performed.

INPUT/OUTPUT CONFIGURATIONS

The schematic diagrams of the input and output circuits of the logic section are shown below:

INPUT PIN: CLK, CE, DI, /INH

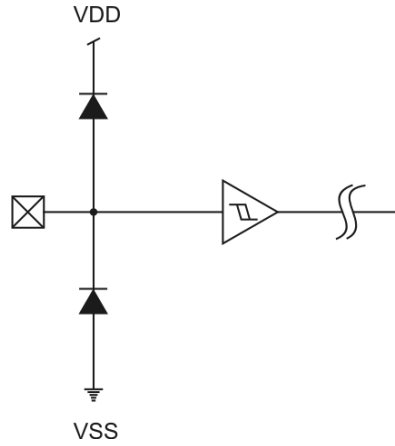

OUTPUT PIN: COM1 TO COM4, SG13 TO SG51

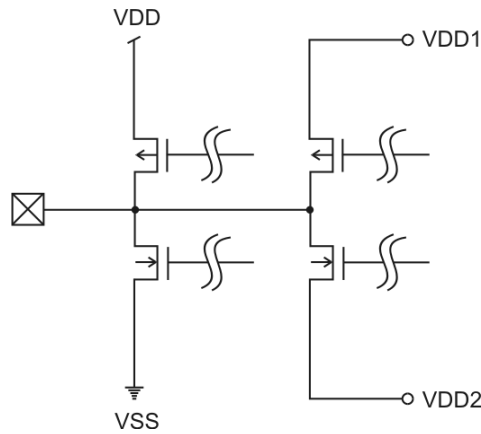

OUTPUT PIN: SG1/P1 TO SG12/P12

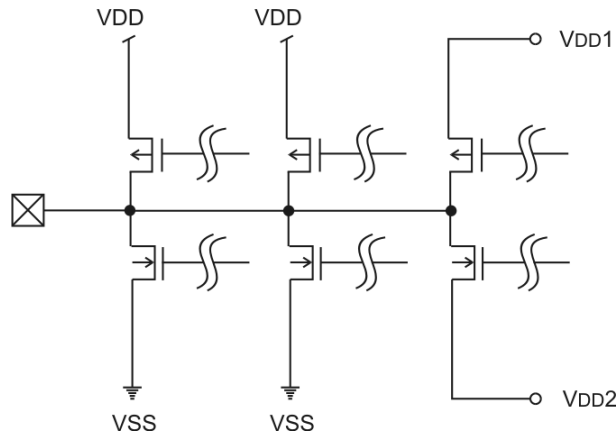

UNCTION DESCRIPTION

CONTROL DATA BITS

CU: NORMAL MODE CURRENT DRAIN CONTROL DATA BIT

This control bit is used to select the current drain (either Normal Current Drain or Low Current Drain) in the Normal Mode. Please refer to the table below.

CU	Current Drain (under the Normal Mode)
0	Normal Current Drain (IDD2, IDD3)
1	Low Current Drain (IDD4, IDD5)

It should be noted that when the Low Current Drain is selected by setting the CU to “1”, the output waveforms of the common and segment driver are easily distorted since the capacity to supply the current to the LCD panel from the Common and Segment Pins is less than capacity under the Normal Current Drain (CU = “0”).

P0 TO P3: SEGMENT / GENERAL PURPOSE OUTPUT PORT SELECT BITS

These control bits are used to select the function of the SG1/P1 to SG12/P12 output pins (either Segment Output Pins or General Purpose Output Pins). Please refer to the table below.

Control Data				Output Pins											
P0	P1	P2	P3	SG1/ P1	SG2/ P2	SG3/ P3	SG4/ P4	SG5/ P5	SG6/ P6	SG7/ P7	SG8/ P8	SG9/ P9	SG10 /P10	SG11 /P11	SG12/ P12
0	0	0	0	SG1	SG2	SG3	SG4	SG5	SG6	SG7	SG8	SG9	SG10	SG11	SG12
0	0	0	1	P1	SG2	SG3	SG4	SG5	SG6	SG7	SG8	SG9	SG10	SG11	SG12
0	0	1	0	P1	P2	SG3	SG4	SG5	SG6	SG7	SG8	SG9	SG10	SG11	SG12
0	0	1	1	P1	P2	P3	SG4	SG5	SG6	SG7	SG8	SG9	SG10	SG11	SG12
0	1	0	0	P1	P2	P3	P4	SG5	SG6	SG7	SG8	SG9	SG10	SG11	SG12
0	1	0	1	P1	P2	P3	P4	P5	SG6	SG7	SG8	SG9	SG10	SG11	SG12
0	1	1	0	P1	P2	P3	P4	P5	P6	SG7	SG8	SG9	SG10	SG11	SG12
0	1	1	1	P1	P2	P3	P4	P5	P6	P7	SG8	SG9	SG10	SG11	SG12
1	0	0	0	P1	P2	P3	P4	P5	P6	P7	P8	SG9	SG10	SG11	SG12
1	0	0	1	P1	P2	P3	P4	P5	P6	P7	P8	P9	SG10	SG11	SG12
1	0	1	0	P1	P2	P3	P4	P5	P6	P7	P8	P9	P10	SG11	SG12
1	0	1	1	P1	P2	P3	P4	P5	P6	P7	P8	P9	P10	P11	SG12
1	1	0	0	P1	P2	P3	P4	P5	P6	P7	P8	P9	P10	P11	P12

When the General Purpose Output Port Function is selected, the correspondence between the output pins and the respective display data is given in the table below.

Output Pin	Corresponding Display Data	Output Pin	Corresponding Display Data
SG1/P1	D1	SG7/P7	D25
SG2/P2	D5	SG8/P8	D29
SG3/P3	D9	SG9/P9	D33
SG4/P4	D13	SG10/P10	D37
SG5/P5	D17	SG11/P11	D41
SG6/P6	D21	SG12/P12	D45

When the General Purpose Output Port Function is selected, the respective output pin is output a “HIGH” level when its corresponding display data is set to “1”. Likewise, it will output a “LOW” level, if its corresponding display data is set to “0”.

For example, SG4/P4 is used as a General Purpose Output Port, if its corresponding display data – D13 is set to “1”, then SG4/P4 will output “HIGH” level. Likewise, if D13 is set to “0”, then SG4/P4 will output “LOW” level.

DR: BIAS DRIVE TECHNIQUE CONTROL DATA BIT

This control bit is used to select either 1/2 Bias drive or 1/3 Bias Drive Technique. Please refer to the table below.

DR	Bias Drive Technique
0	1/3
1	1/2

SC: SEGMENT ON / OFF CONTROL DATA BIT

This control bit is used to select the state of the segment driver output pins. Please refer to the table below.

SC	Display State
0	ON
1	OFF

BU: NORMAL / POWER SAVING MODE SELECT BIT

This control bit is used to select either the Normal Mode or the Power Saving Mode. Please refer to the table below.

BU	Mode	Remarks
0	Normal Mode	-
1	Power Saving Mode	The oscillation circuit stops, the common and segment output pins are set to "LOW" level. It must be noted that the output pins - SG1/P1 to SG12/P12 may be used as General Purpose Output Ports by setting the control bits – P0 to P3.

DISPLAY CONTROL AND THE /INH PIN

When power is initialized, the internal data of PT6526 (that is, display data – D1 to D204 and the control data) are not defined. Irrelevant displays caused by the undefined internal data can be prevented by using the following procedures. The /INH pin must be set to “LOW” at the same time as the power is applied to turn OFF the display. Doing this will set the output pins – SG1/P1 to SG12/P12, SG13 to SG51 and COM1 to COM4 to “LOW” level. While the /INH pin is held at “LOW” level, the microcontroller must send the serial data. Then the application can set the /INH pin to “HIGH”. Please refer to the figure below.

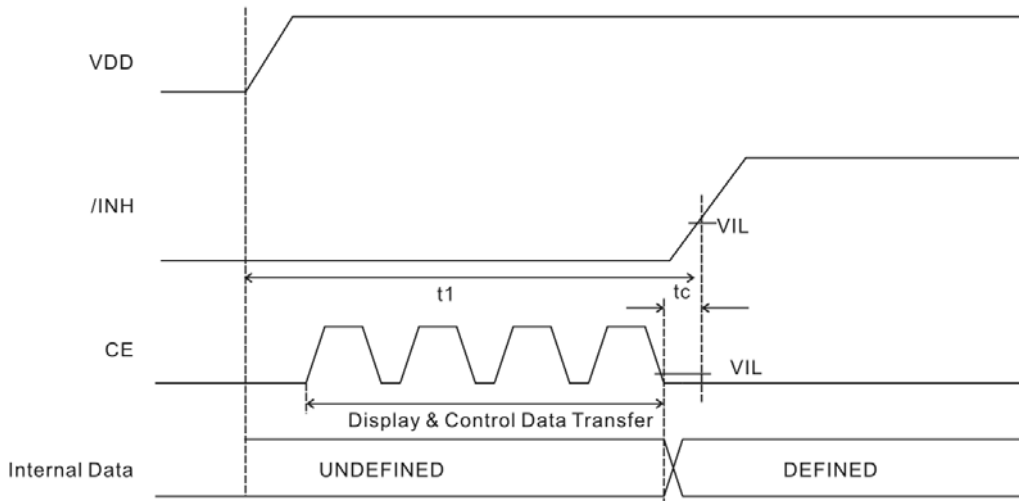
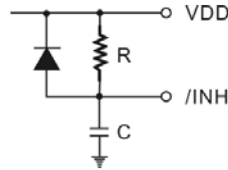

Notes:

1. t_1 = determined by the value of C and R.
2. t_c = 10us (minimum)

DISPLAY DATA AND THE OUTPUT PIN CORRESPONDENCE

Output Pin	COM1	COM2	COM3	COM4
SG1/P1	D1	D2	D3	D4
SG2/P2	D5	D6	D7	D8
SG3/P3	D9	D10	D11	D12
SG4/P4	D13	D14	D15	D16
SG5/P5	D17	D18	D19	D20
SG6/P6	D21	D22	D23	D24
SG7/P7	D25	D26	D27	D28
SG8/P8	D29	D30	D31	D32
SG9/P9	D33	D34	D35	D36
SG10/P10	D37	D38	D39	D40
SG11/P11	D41	D42	D43	D44
SG12/P12	D45	D46	D47	D48
SG13	D49	D50	D51	D52
SG14	D53	D54	D55	D56
SG15	D57	D58	D59	D60
SG16	D61	D62	D63	D64
SG17	D65	D66	D67	D68
SG18	D69	D70	D71	D72
SG19	D73	D74	D75	D76
SG20	D77	D78	D79	D80
SG21	D81	D82	D83	D84
SG22	D85	D86	D87	D88
SG23	D89	D90	D91	D92
SG24	D93	D94	D95	D96
SG25	D97	D98	D99	D100
SG26	D101	D102	D103	D104
SG27	D105	D106	D107	D108
SG28	D109	D110	D111	D112
SG29	D113	D114	D115	D116
SG30	D117	D118	D119	D120
SG31	D121	D122	D123	D124
SG32	D125	D126	D127	D128
SG33	D129	D130	D131	D132
SG34	D133	D134	D135	D136
SG35	D137	D138	D139	D140
SG36	D141	D142	D143	D144
SG37	D145	D146	D147	D148
SG38	D149	D150	D151	D152
SG39	D153	D154	D155	D156
SG40	D157	D158	D159	D160
SG41	D161	D162	D163	D164
SG42	D165	D166	D167	D168
SG43	D169	D170	D171	D172
SG44	D173	D174	D175	D176
SG45	D177	D178	D179	D180
SG46	D181	D182	D183	D184
SG47	D185	D186	D187	D188
SG48	D189	D190	D191	D192
SG49	D193	D194	D195	D196
SG50	D197	D198	D199	D200
SG51	D201	D202	D203	D204

Note: The Segment Output Port function is assumed to be selected for the output pins – SG1/P1 to SG12/P12.

To illustrate further, the states of the S21 output pin is given in the table below.

Display Data				State of SG21 Output Pin
D81	D82	D83	D84	
0	0	0	0	LCD Segments corresponding to COM1 to COM4 are OFF.
0	0	0	1	LCD Segment corresponding to COM4 is ON.
0	0	1	0	LCD Segment corresponding to COM3 is ON.
0	0	1	1	LCD Segments corresponding to COM3 and COM4 are ON.
0	1	0	0	LCD Segment corresponding to COM2 is ON.
0	1	0	1	LCD Segments corresponding to COM2 and COM4 are ON.
0	1	1	0	LCD Segments corresponding to COM2 and COM3 are ON.
0	1	1	1	LCD Segments corresponding to COM2, COM3 and COM4 are ON.
1	0	0	0	LCD Segment corresponding to COM1 is ON.
1	0	0	1	LCD Segments corresponding to COM1 and COM4 are ON.
1	0	1	0	LCD Segments corresponding to COM1 and COM3 are ON.
1	0	1	1	LCD Segments corresponding to COM1, COM3 and COM4 are ON.
1	1	0	0	LCD Segments corresponding to COM1 and COM2 are ON.
1	1	0	1	LCD Segments corresponding to COM1, COM2, and COM4 are ON.
1	1	1	0	LCD Segments corresponding to COM1, COM2, and COM3 are ON.
1	1	1	1	LCD Segments corresponding to COM1 and COM 4 are ON.

SERIAL DATA INPUT

CONDITION 1: WHEN CLK IS TERMINATED AT “LOW” LEVEL

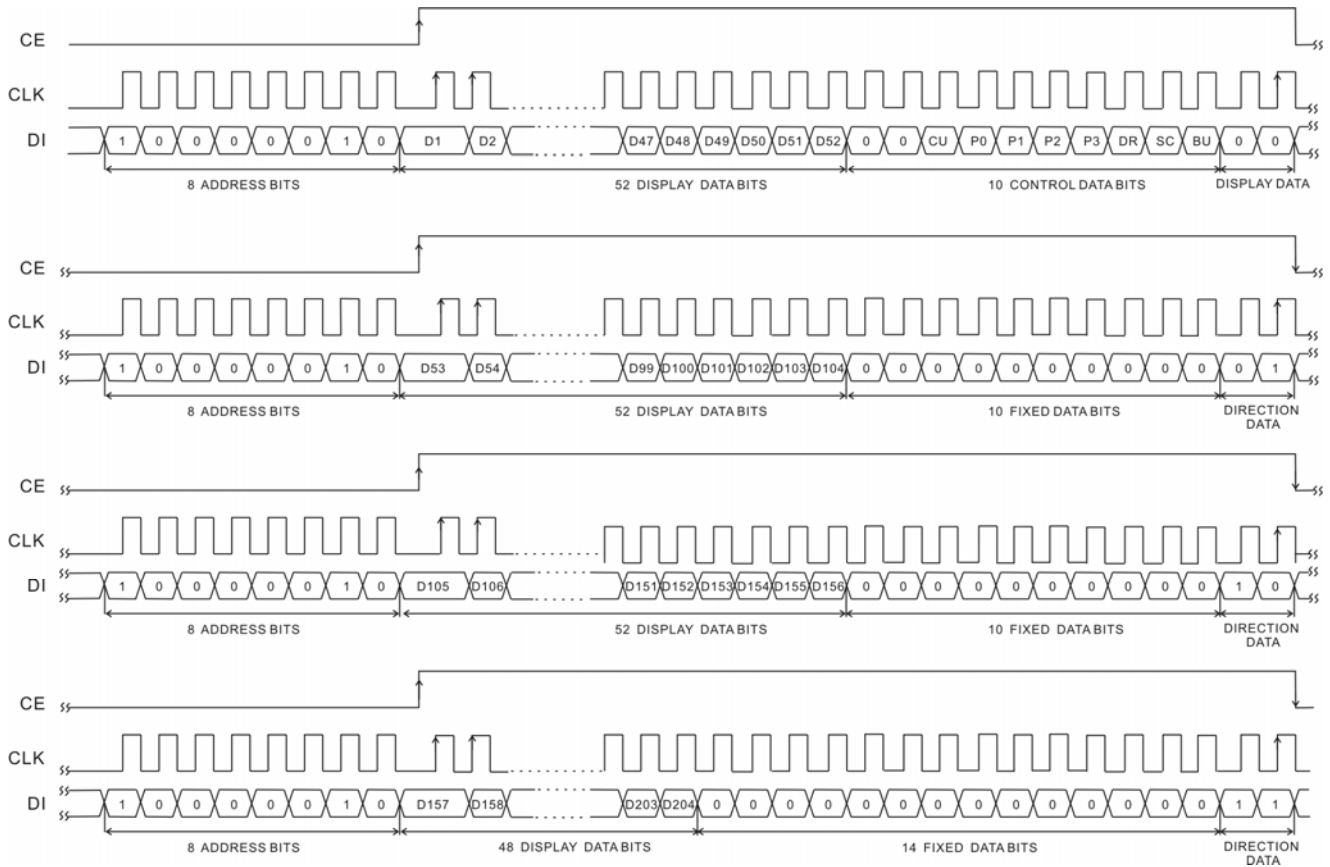

Notes:

1. Address: 41H
2. D1 to D204: Display Data
3. CU: Normal Mode Current Drain Control Data
4. P0 to P3: Segment Output Port/General Purpose Port Control Data Bit
5. DR: 1/2 or 1/3 Bias Drive Control Data Bit
6. SC: Segment ON /OFF Control Data Bit
7. BU: Normal Mode/Power-Saving Mode Control Data Bit

CONDITION 2: WHEN CLK IS TERMINATED AT "HIGH" LEVEL

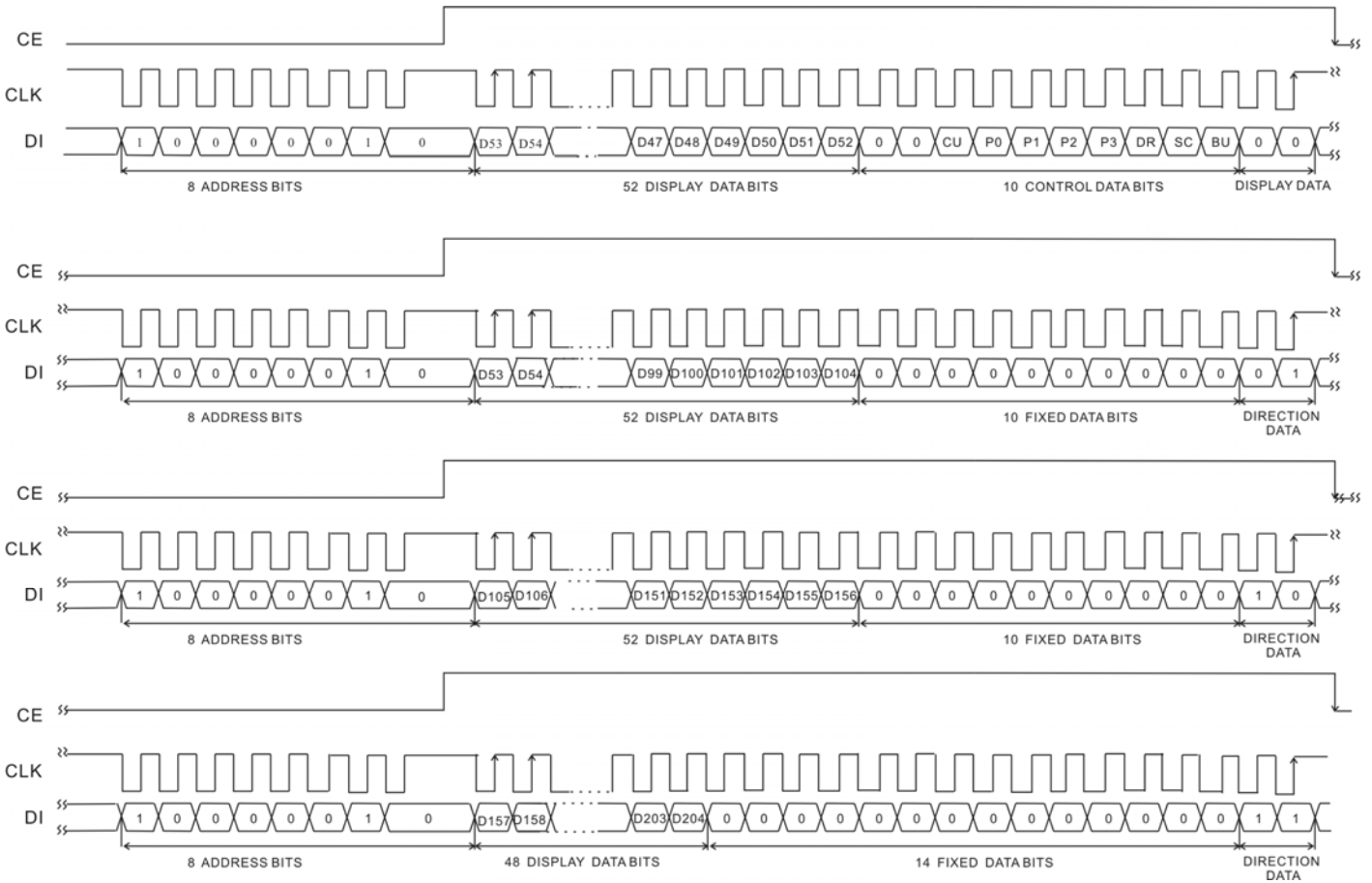

Notes:

1. Address: 41H
2. D1 to D204: Display Data
3. CU: Normal Mode Current Drain Control Data
4. P0 to P3: Segment Output Port / General Purpose Port Control Data Bit
5. DR: 1/2 or 1/3 Bias Drive Control Data Bit
6. SC: Segment ON /OFF Control Data Bit
7. BU: Normal Mode/Power-Saving Mode Control Data Bit

SERIAL DATA TRANSFER

SERIAL DATA TRANSFER FOR 157 OR MORE SEGMENTS

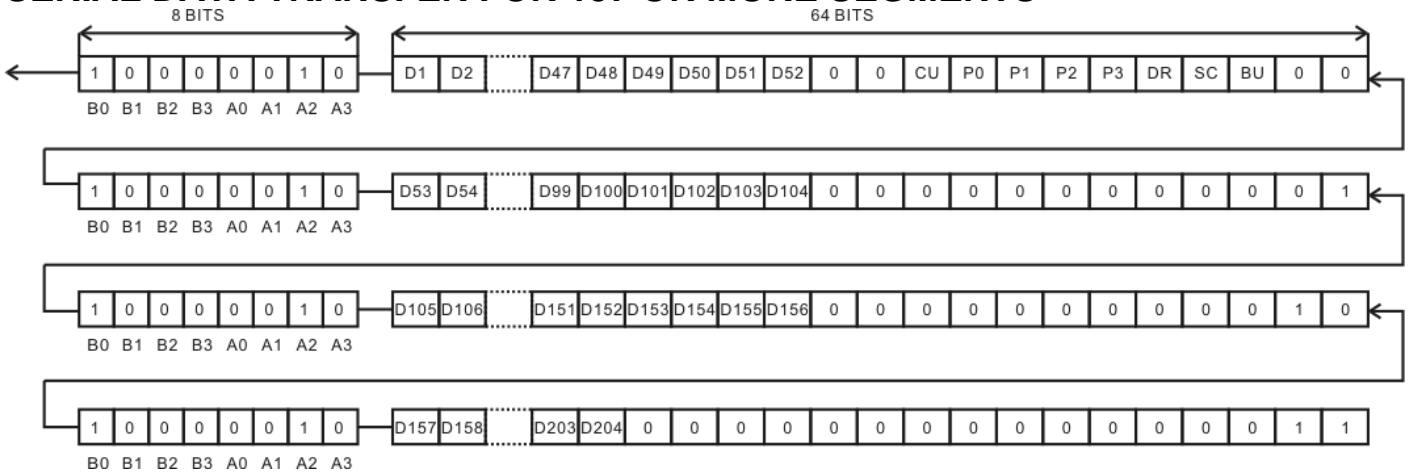

SERIAL DATA TRANSFER FOR LESS THAN 157 SEGMENTS

Under a serial data transfer whereby less than 157 segments are used, 64, 128 or 192 bits of serial data must be transmitted depending on the actual number of segments used. The display data bits D1 to D52 and the control data must always sent. Please refer to the figure below.

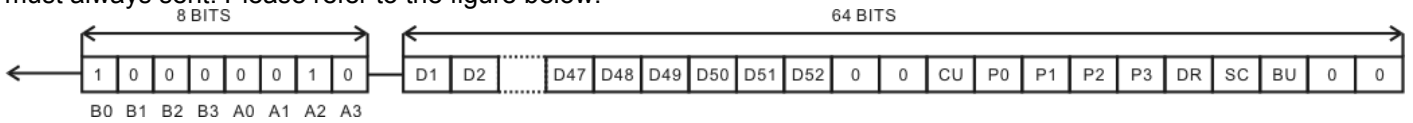

1/4 DUTY, 1/2 BIAS DRIVE TECHNIQUE

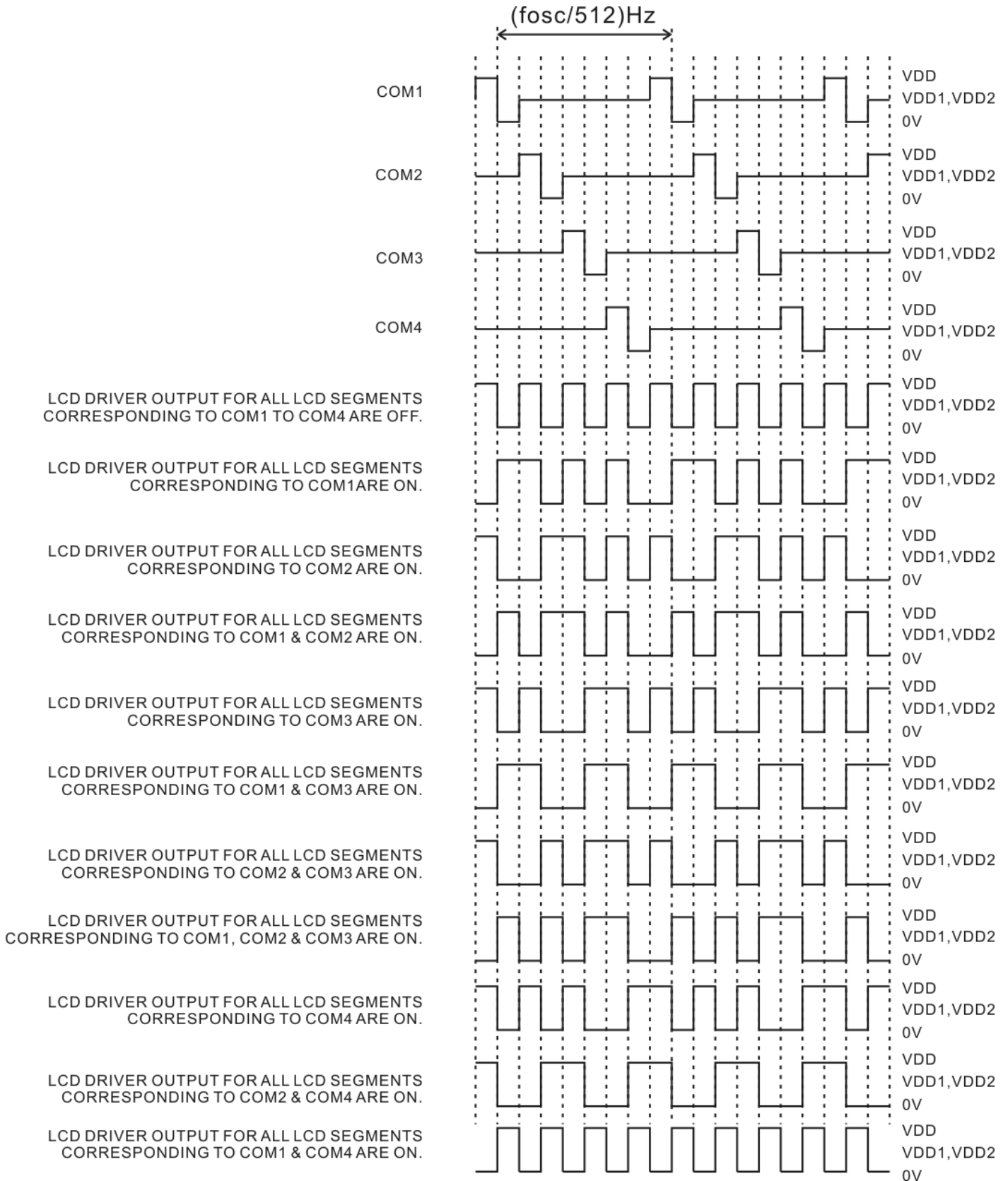

1/4 DUTY, 1/3 BIAS DRIVE TECHNIQUE

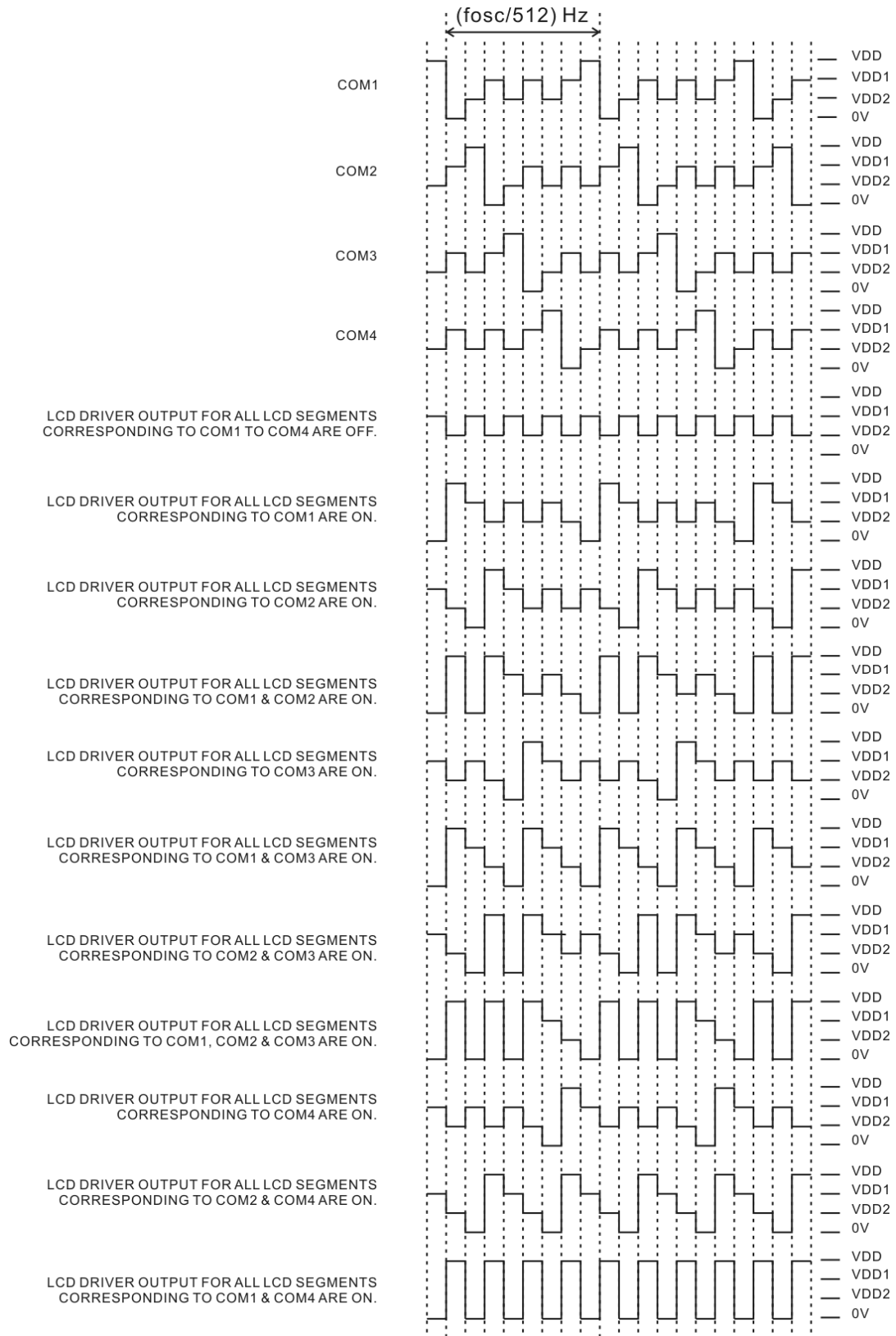

ABSOLUTE MAXIMUM RATING

(Unless otherwise stated, Ta=25°C, Vss=0V)

Parameter	Symbol	Condition	Rating	Unit
Maximum Supply Voltage	VDDmax	VDD	-0.3 to +7.0	V
Input Voltage	VIN1	CE, CLK, DI, /INH	-0.3 to +7.0	V
	VIN2	OSC, VDD1, VDD2	-0.3 to VDD+0.3	V
Output Voltage	VOUT	OSC, SG1 to SG51, COM1 to COM4, P1 to P12	-0.3 to VDD+0.3	V
Output Current	IOUT1	SG1 to SG51	300	μA
	IOUT2	COM1 to COM4	3	mA
	IOUT3	P1 to P12	5	mA
Allowable Power Dissipation	PDmax	Ta=85°C	200	mW
Operating Temperature	Topr		-40 to +85	°C
Storage Temperature	Tstg		-65 to +150	°C

ALLOWABLE OPERATING RANGE

(Unless otherwise stated, Ta=25°C, Vss=0V)

Parameter	Symbol	Condition	Min.	Typ.	Max.	Unit
Supply Voltage	VDD	VDD	4.5	-	6.0	V
Input Voltage	VDD1	VDD1	-	2/3VDD	VDD	V
	VDD2	VDD2	-	1/3VDD	VDD	V
High Level Input Voltage	VIH	CE, CLK, DI, /INH	2.4	-	VDD	V
Low Level Input Voltage	VIL	CE, CLK, DI, /INH	0	-	0.7	V
Recommended External Resistance	Rosc	OSC	-	270	-	KΩ
Recommended External Capacitance	Cosc	OSC	-	100	-	pF
Guaranteed Oscillation Range	fosc	OSC	25	50	100	KHz
Data Setup Time	tds	CLK, DI (see Note)	160	-	-	ns
Data Hold Time	tdh	CLK, DI (see Note)	160	-	-	ns
CE Wait Time	tcp	CE, CLK (see Note)	160	-	-	ns
CE Setup Time	tcs	CE, CLK (see Note)	160	-	-	ns
CE Hold Time	tch	CE, CLK (see Note)	160	-	-	ns
High Level Clock Pulse Width	tΦH	CLK (see Note)	160	-	-	ns
Low Level Clock Pulse Width	tΦL	CLK, (see Note)	160	-	-	ns
Rise Time	tr	CE, CLK, DI (see Note)	-	160	-	ns
Fall Time	tf	CE, CLK, DI (see Note)	-	160	-	ns
/INH Switching Time	tc	/INH, CE (see Note)	10	-	-	μs

Notes:

1. When CLK is terminated at "LOW" level

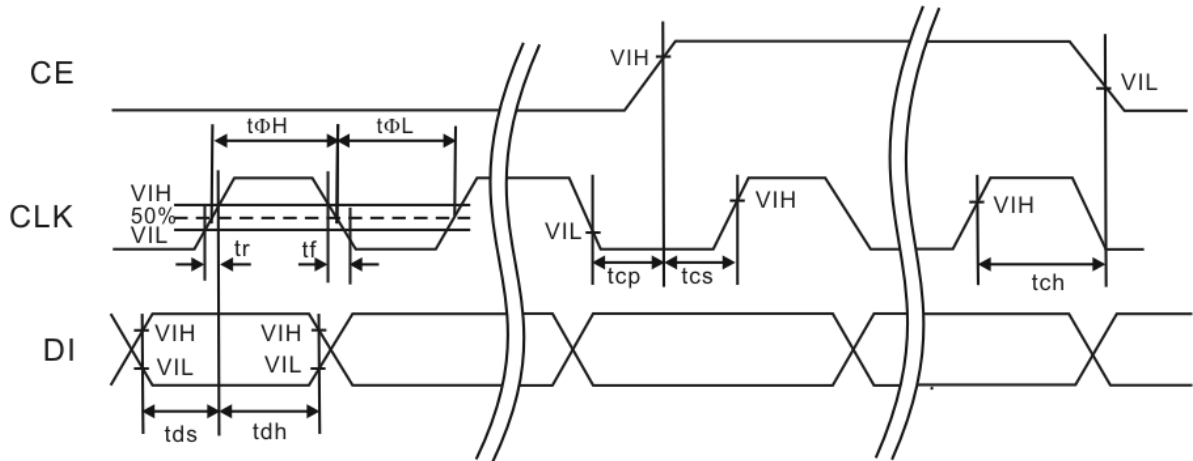

2. When CLK is terminated at "HIGH" level.

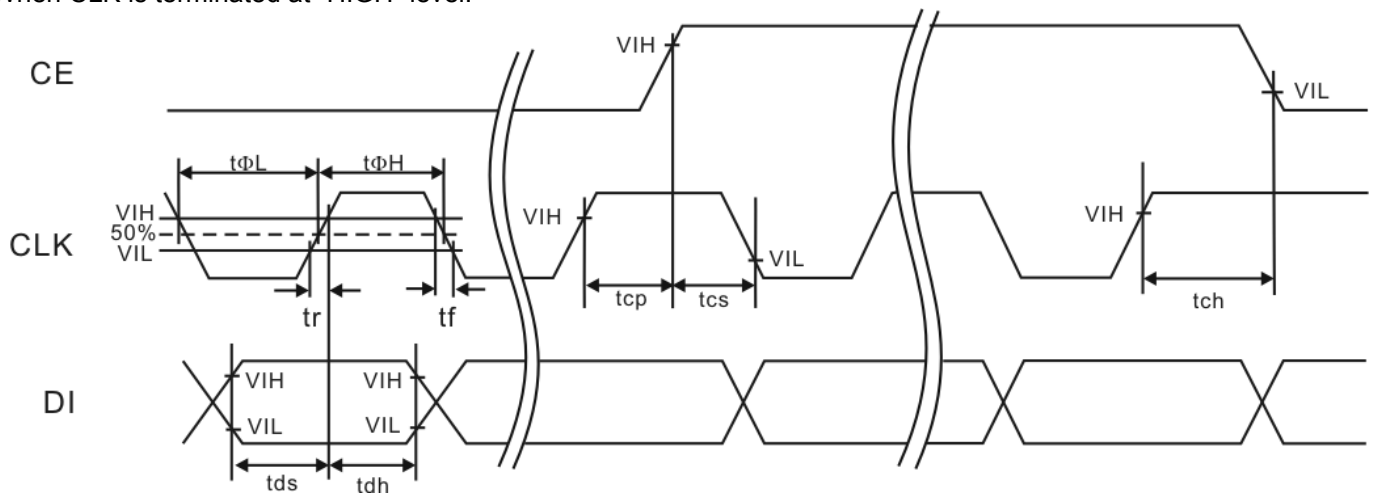

ELECTRICAL CHARACTERISTICS

(Unless otherwise stated, Ta=25°C, Vss=0V)

Parameter	Symbol	Conditions	Min.	Typ.	Max.	Unit
Hysteresis	VH	CE, CLK, DI, /INH	-	0.1VDD	-	V
High Level Input Current	I _{IH}	CE, CLK, DI, /INH VI=6.0V	-	-	5.0	μA
Low Level Input Current	I _{IL}	CE, CLK, DI, /INH VI=0V	-5.0	-	-	μA
High Level Output Voltage	VOH1	SG1 to SG51 I _o =-20μA	VDD-1.0	-	-	V
	VOH2	COM1 to COM2 I _o =-100μA	VDD-1.0	-	-	V
	VOH3	P1 to P12 I _o =-1mA	VDD-1.0	-	-	V
Low Level Output Voltage	VOL1	SG1 to SG51 I _o =20μA	-	-	1.0	V
	VOL2	COM1 to COM4 I _o =100μA	-	-	1.0	V
	VOL3	P1 to P12 I _o =1mA	-	-	1.0	V
Middle Level Output Voltage	VMID1	COM1 to COM4 1/2 Bias, I _o =±100μA	1/2VDD-1.0	-	1/2VDD+1.0	V
	VMID2	SG1 to SG51 1/3 Bias, I _o =±20μA	2/3VDD-1.0	-	2/3VDD+1.0	V
	VMID3	SG1 to SG51 1/3 Bias, I _o =±20μA	1/3VDD-1.0	-	1/3VDD+1.0	V
	VMID4	COM1 to COM4 1/3 Bias, I _o =±100μA	2/3VDD-1.0	-	2/3VDD+1.0	V
	VMID5	COM1 to COM4 1/3 Bias, I _o =±100μA	1/3VDD-1.0	-	1/3VDD+1.0	V
Oscillation Frequency	F _{osc}	OSC R _{osc} =270KΩ, C _{osc} =100pF	40	50	60	KHz
Current Drain	IDD1	Power Saving Mode	-	-	5	μA
	IDD2	VDD=6V Outputs Open 1/2 Bias, f _{osc} =50KHZ Control Data CU=0	-	200	400	μA
	IDD3	VDD=6.0V Outputs Open 1/3 Bias, f _{osc} =50KHz Control Data CU=0	-	250	500	μA
	IDD4	VDD=6.0V Outputs Open 1/2 Bias, f _{osc} =50KHz Control Data CU=1	-	130	260	μA
	IDD5	VDD=6.0 Outputs Open 1/3 Bias, f _{osc} =50KHz Control Data CU=1	-	150	300	μA

Note: The Bias Voltage Generation Divider built-into the VDD1 and VDD2 are not included. Please refer to the diagram below.

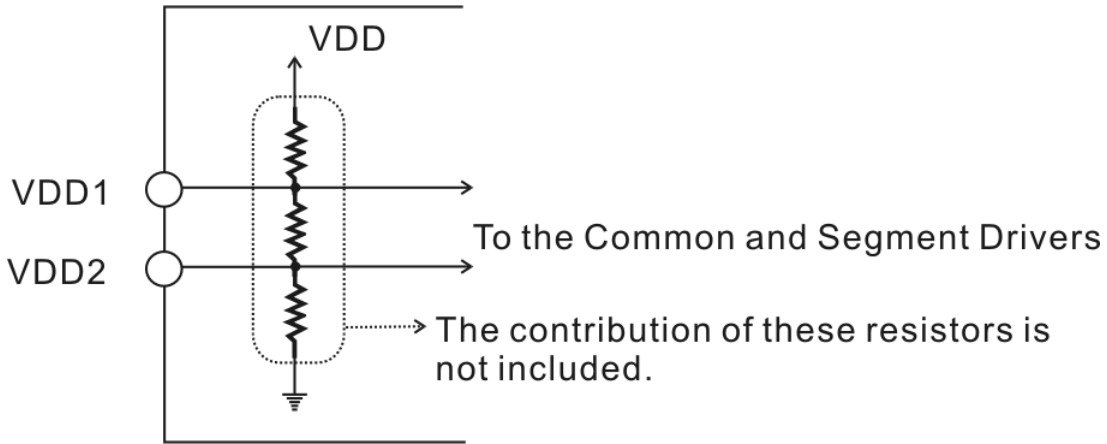

PACKAGE INFORMATION

64 PINS, LQFP (BODY SIZE: 10mm x 10mm, PITCH: 0.50mm, THK BODY: 1.40mm)

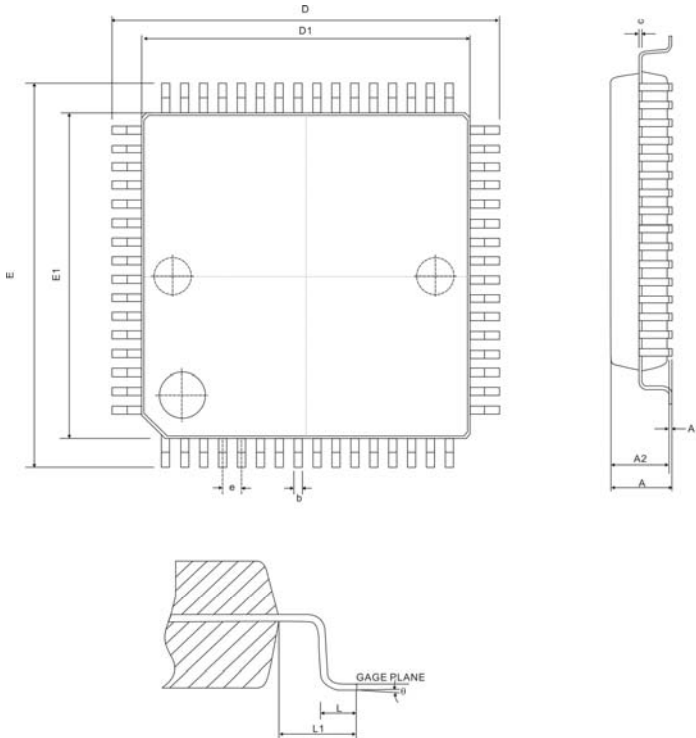

Symbol	Min.	Nom.	Max.
A	-	-	1.60
A1	0.05	-	0.15
A2	1.35	1.40	1.45
b	0.17	0.22	0.27
c	0.09	-	0.20
D	11.80	12.00	12.20
D1	9.90	10.00	10.10
E	11.80	12.00	12.20
E1	9.90	10.00	10.10
e	0.50 BSC		
L	0.45	0.60	0.75
L1	1.00 REF		
θ	0°	3.5°	7°

Notes:

1. Unit: mm
2. Refer to JEDEC MS-026BCB

IMPORTANT NOTICE

Princeton Technology Corporation (PTC) reserves the right to make corrections, modifications, enhancements, improvements, and other changes to its products and to discontinue any product without notice at any time.

PTC cannot assume responsibility for use of any circuitry other than circuitry entirely embodied in a PTC product. No circuit patent licenses are implied.

Princeton Technology Corp.
2F, 233-1, Baociao Road,
Sindian, Taipei 23145, Taiwan
Tel: 886-2-66296288
Fax: 886-2-29174598
<http://www.princeton.com.tw>