



## DESCRIPTION

PT9258 is a single chip GPS receiver SoC that integrates RF and Baseband in an 8 x 8 x 0.9 mm QFN package. The SoC together with few external components builds stand-alone GPS receivers that track GPS satellite signals, and stream out NMEA 0183 message that contains current location and time information. PT9258 do not rely on host processor for positioning computation.

The receiver accepts L1-band C/A code GPS and A-GPS signals. Typical application consists of LNA and SAW filter behind GPS antenna before feeding to the on-chip LNA input of PT9258. 0.5ppm 16.369MHz TCXO as clock source is preferred for tracking of the GPS signal. System level functions such as Power-On-Reset, 3.3V to 1.2V switching regulator and low quiescent current RTC LDO are integrated in PT9258.

Offered in both ROM-based PT9258R and Flash-memory-based PT9258E options; the non-volatile ROM version provides standard function, while Flash version is available for firmware upgrade or add-on features. Flash version is delivered un-programmed, which is usually performed after PCB assembly and before test. ROM and Flash version has same package outline, a mode select pin differentiates the two options. For more flexibility to the fixed ROM firmware, PT9258R also provides a configuration mechanism that can store one set of firmware option settings permanently to a serial EEPROM on PT9258R's I<sup>2</sup>C bus.

PT9258's easiness and flexibility of system design together with the top-notch navigation performance and low power consumption thus makes PT9258 the best candidate for location-based services.

## FEATURES

- RF, Baseband and Memory Integrated single chip
- ROM and Flash options in same package
- Configuration-Backup Serial EEPROM (ROM version, optional)
- Integrated Switch Mode Regulator, Low Quiescent Current RTC LDO
- Serial port: UART, I<sup>2</sup>C, and SPI
- Digital I/O: GPIO, 1PPS, Rx Status LED, and Interrupt
- NMEA-0183, Ver. 3.01
- Supports SBAS: WAAS, EGNOS, MSAS, and GAGAN
- QFN 64 pin 8 x 8 x 0.9 mm package
- Pb Free and RoHS compliant
- Temperature range -40°C to +85°C

## HIGHLIGHTS

- Superior navigation performance
- Low power consumption during both satellite search and track
- Flexible ROM and Flash product options

## APPLICATIONS

- Navigator
- Tracker
- Geo tagger
- Speed indicator
- Time base server
- Other location based services

# BLOCK DIAGRAM

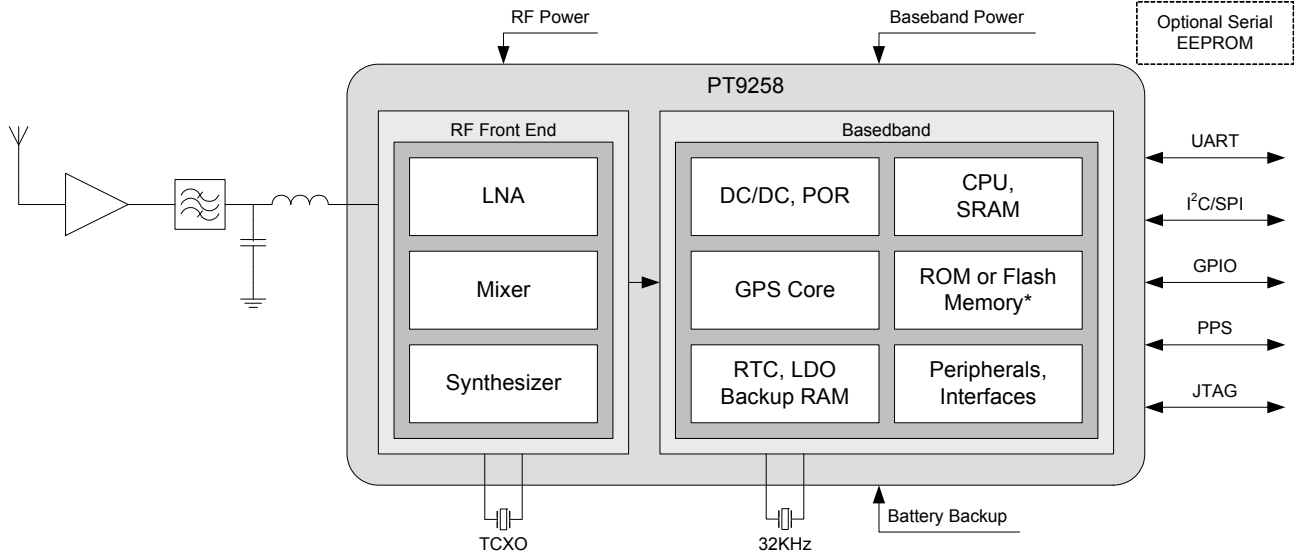

# REFERENCE APPLICATION CIRCUIT

36 pin, 13.1mmx15.9mm, PT9258R module schematic

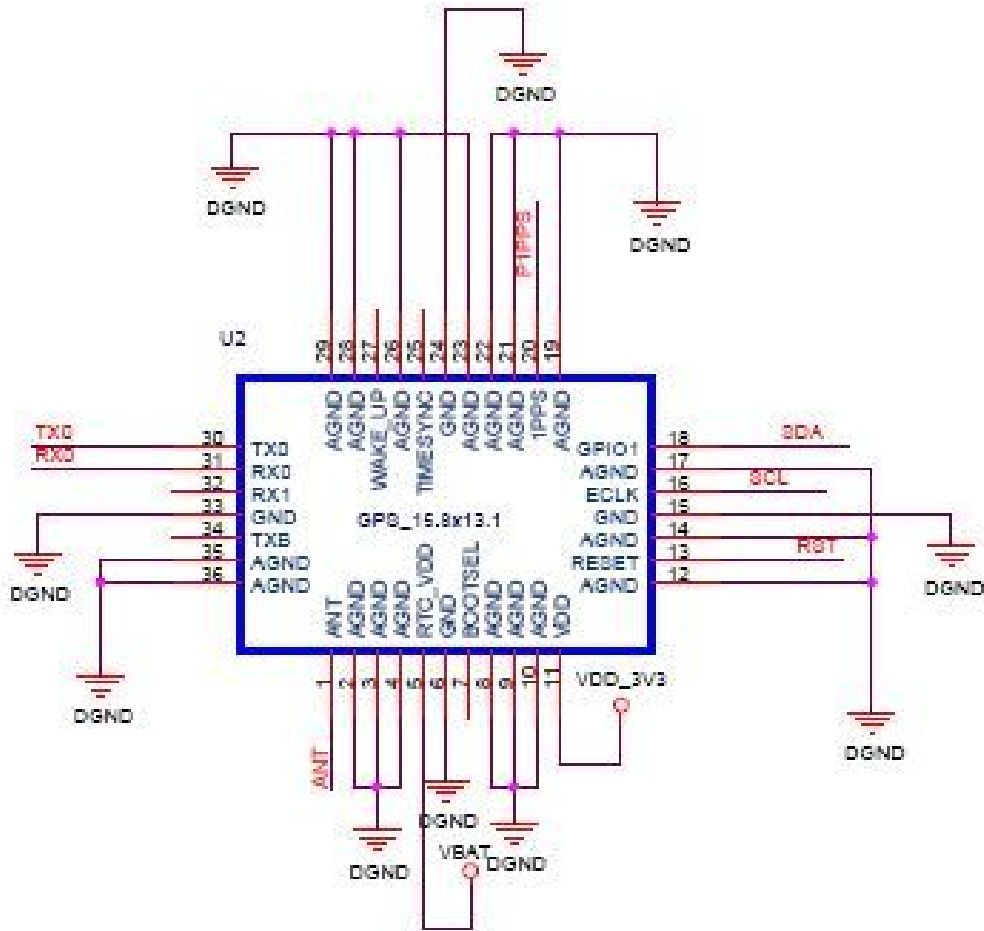

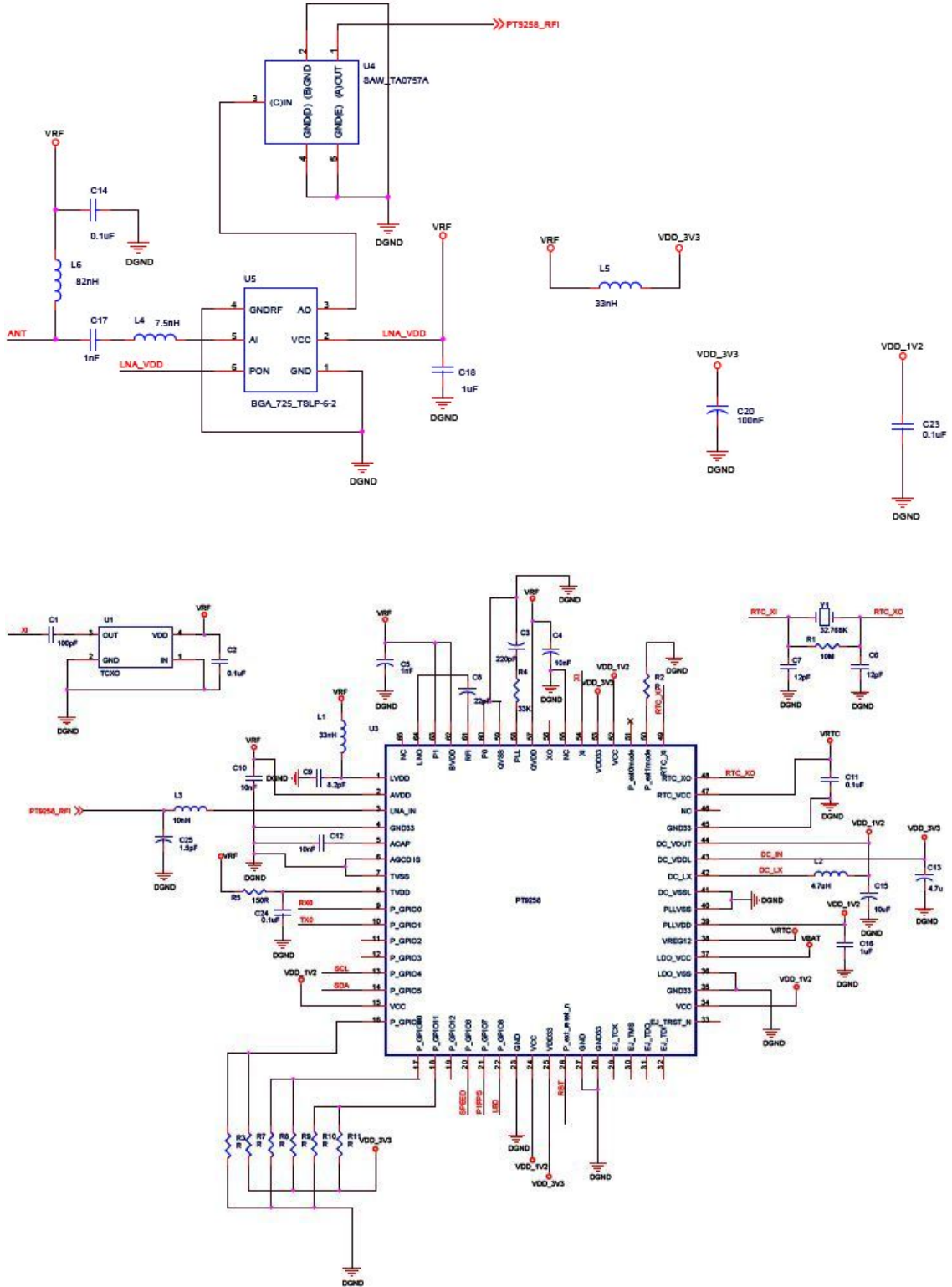



# REFERENCE BILL OF MATERIALS

PTC 普誠科技股份有限公司 Princeton Technology Corp.									
PT9258 V06									
2012/12/12									
Item	Description	Value	Tolerance	Footprint	Quantity	Designator	Manufactory	Part Number	Remark
1	GPS IC	PT9258E/R		QFN64_8x8mm	1	U3	PTC	PT9258E/PT9258R	
2	GPS L1 LNA	BGA725		TSLP-7-1	1	U5	Infineon	BGA725TSLP-6-2	
3	GPS L1 SAW Filter	TA0587A		1.4x1.1mm	1	U4	TAI-SAW	TA0757A	
4	TCXO	16.369000MHz	0.5ppm	2.5x2.0mm	1	U1	RAKON	IT2200B	
5	XTAL	32.768KHz	20ppm	3.2x1.5mm	1	Y1	TAITIEN	XDMCHLNDDF-0.032768MHz	
6	Capacitor	1.5pF	0.25pF	0402(1.0x0.5mm)	1	C25	TDK	C1005C0G1H1R5C	
8	Capacitor	8.2pF	0.5pF	0402(1.0x0.5mm)	1	C9	TDK	C1005C0G1H080D	
10	Capacitor	12pF	5%	0402(1.0x0.5mm)	2	C6,C7	TDK	C1005C0G1H120J	
11	Capacitor	22pF	5%	0402(1.0x0.5mm)	1	C8	TDK	C1005C0G1H220J	
12	Capacitor	100pF	5%	0402(1.0x0.5mm)	1	C1	TDK	C1005C0G1H101J	
13	Capacitor	220pF	10%	0402(1.0x0.5mm)	1	C3	TDK	C1005C0G1H221K	
14	Capacitor	1nF	10%	0402(1.0x0.5mm)	2	C5,C17	TDK	C1005X7R1H102K	
15	Capacitor	10nF	10%	0402(1.0x0.5mm)	3	C4,C10,C12	TDK	C1005X7R1H103K	
16	Capacitor	100nF	10%	0402(1.0x0.5mm)	1	C20	TDK	C1005X7R1H104K	
17	Capacitor	0.1uF	10%	0402(1.0x0.5mm)	5	C2, C11,C14,C23,C24	TDK	C1005X7R1H104K	
18	Capacitor	1uF	10%	0402(1.0x0.5mm)	5	C2,C16,C18,C21,C22	TDK	C1005X5R0J105K	
19	Capacitor	4.7uF	10%	0402(1.0x0.5mm)	1	C13			
20	Capacitor	10uF	20%	0603(1.6x0.8mm)	1	C15	TDK	C1608X5R1A106M	
21	Inductor	4.7nH	0.3nH	0402(1.0x0.5mm)	1	L4	TOKO	LL1005-FH4N7S	
22	Inductor	10nH	5%	0402(1.0x0.5mm)	1	L3	TOKO	LL1005-FH10NJ	
23	Inductor	33nH	5%	0402(1.0x0.5mm)	2	L1,L5	TOKO	LL1005-FH33NJ	
24	Inductor	82nH	5%	0402(1.0x0.5mm)	1	L6	TOKO	LL1005-FH82NJ	
25	Inductor	4.7 uH	5%	0603(1.6x0.8mm)	1	L2			
26	Resistor	R	5%	0402(1.0x0.5mm)	6	R3,R7,R8,R9,R10,R11	EVER OHMS	0402 5% 150R	
27	Resistor	150 Ohm	5%	0402(1.0x0.5mm)	2	R5,R6	EVER OHMS	0402 5% 200R	
28	Resistor	33K Ohm	5%	0402(1.0x0.5mm)	1	R4	EVER OHMS	0402 5% 33K	
29	Resistor	10M Ohm	5%	0402(1.0x0.5mm)	1	R1	PHYCOMP	RC0402JR-0710M	
<b>Total</b>					<b>46</b>				



## ORDER INFORMATION

Part Number	Package Type	Description	Top Code
PT9258EA	64 Pins, QFN	Flash type	PT9258EA
PT9258RA-003	64 Pins, QFN	ROM type	PT9258RA

## PIN CONFIGURATION

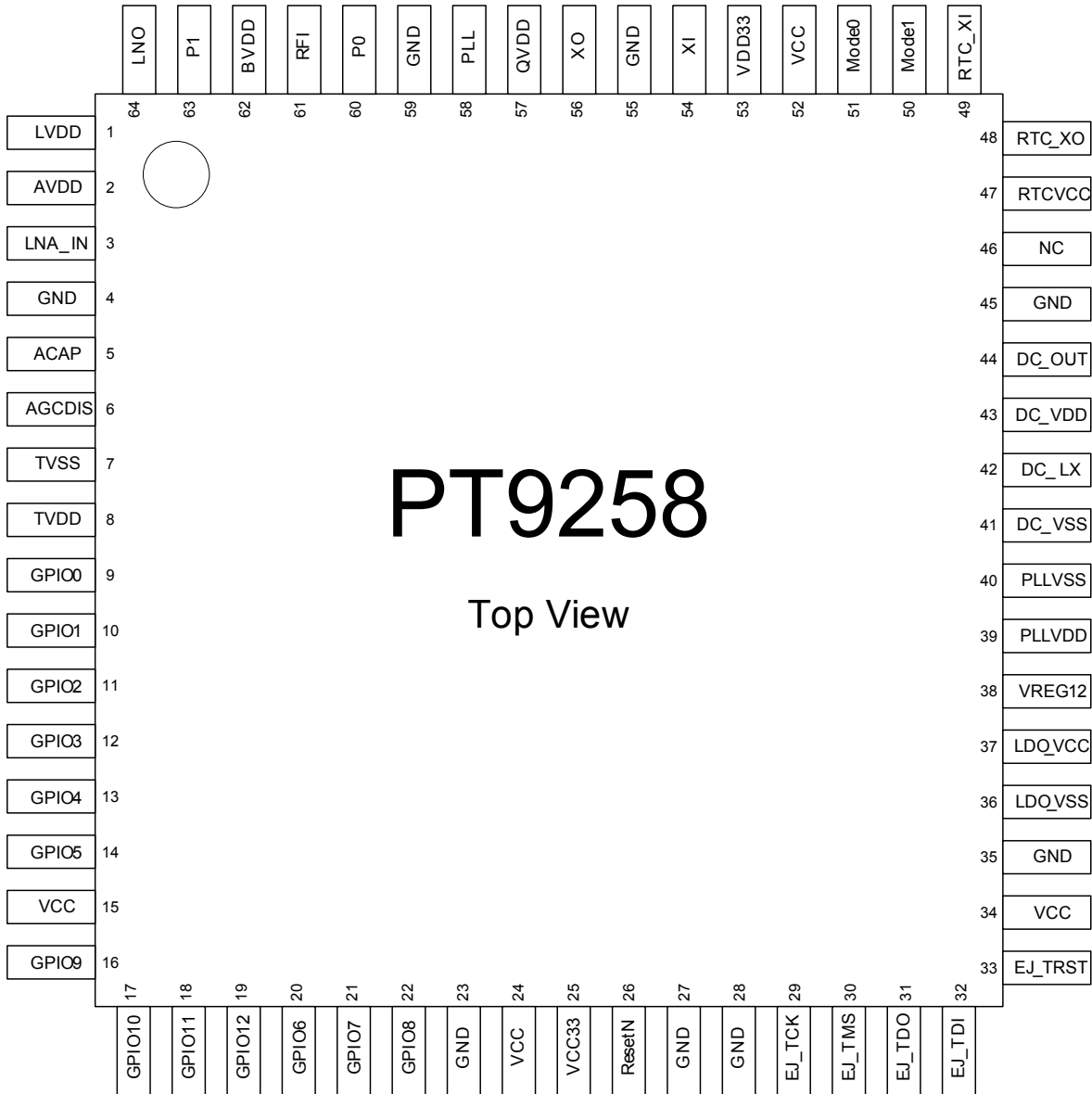



## **IMPORTANT NOTICE**

Princeton Technology Corporation (PTC) reserves the right to make corrections, modifications, enhancements, improvements, and other changes to its products and to discontinue any product without notice at any time.

PTC cannot assume responsibility for use of any circuitry other than circuitry entirely embodied in a PTC product. No circuit patent licenses are implied.

Princeton Technology Corp.  
2F, 233-1, Baociao Road,  
Sindian, Taipei 23145, Taiwan  
Tel: 886-2-66296288  
Fax: 886-2-29174598  
<http://www.princeton.com.tw>