

Ternary PIN Photodiode in TO-Package with Integrated Optics

SRD 00212Z

- InGaAs/InP - PIN-photodiode
- Designed for application in fiber-optic communication systems
- Sensitive receiver for the 2nd and 3rd optical window (1300 nm and 1500 nm)
- Suitable for bit rates up to 1.2 Gbit/s
- Low junction and low package capacitance
- Fast switching times
- Low dark current
- Low noise
- High reverse-current stability by planar structure
- High spectral sensitivity by build in optics
- Hermetically sealed 3-pin metal case
- No z-adjustment necessary (optimum coupling on cap surface)

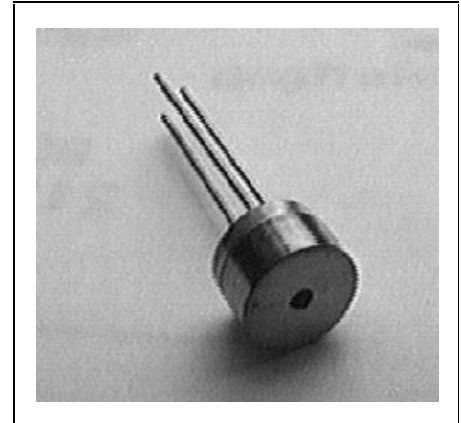

Type	Ordering Code	Connector/Flange
SRD 00212Z	Q62702-P3010	TO, with optics

Component with other pin configuration or other package outlines (cap) on request.

Maximum Ratings

Parameter	Symbol	Values	Unit
Forward current	I_F	10	mA
Reverse voltage	V_R	20	V
Operating and storage temperature	T_A T_{stg}	- 40 ... + 85	°C
Max. radiant power into the opt. port ($V_R = 5$ V)	Φ_{port}	1	mW
Soldering time (wave / dip soldering), distance between solder point and base plate ≥ 2 mm, 260 °C	t_s	10	s

Characteristics

All optical data refer to an optimally coupled 10/125 μm SM fiber.

Parameter	Symbol	Values	Unit
Spectral sensitivity $\lambda = 1300 \text{ nm}, V_R = 5 \text{ V}$	S_λ	0.9 (≥ 0.8)	A/W
Change in spectral sensitivity in operating temperature range	ΔS_λ	< 0.2	%/K
Rise and fall time $R_L = 50 \text{ } \Omega, V_R = 5 \text{ V}, \lambda = 1310 \text{ nm}, \Phi_{\text{port}} = 100 \text{ } \mu\text{W}$	$t_r; t_f$	0.3 (≤ 0.5)	ns
Total capacitance $V_R = 5 \text{ V}, \Phi_{\text{port}} = 0, f = 1 \text{ MHz}$	C_5	1.0 (≤ 1.5)	pF
Dark current $V_R = 5 \text{ V}, T_A = 85 \text{ } ^\circ\text{C}, \Phi_{\text{port}} = 0$	I_D	1 (≤ 50)	nA

Capacitance $C = f(V_R)$

$\Phi_{\text{port}} = 0, f = 1 \text{ MHz}$

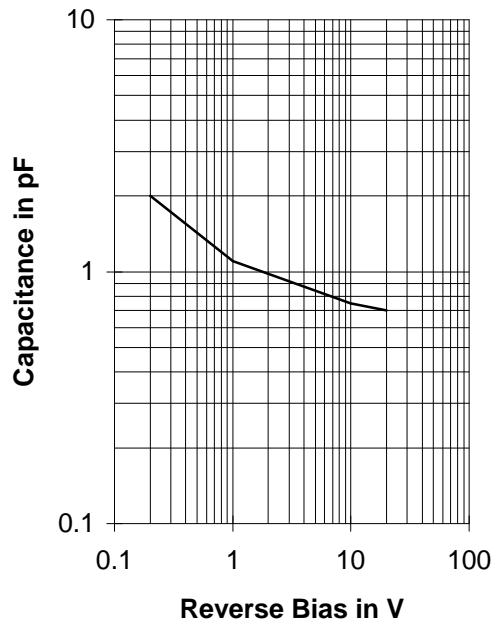

Relative Spectral Sensitivity

$V_R = 5 \text{ V}$

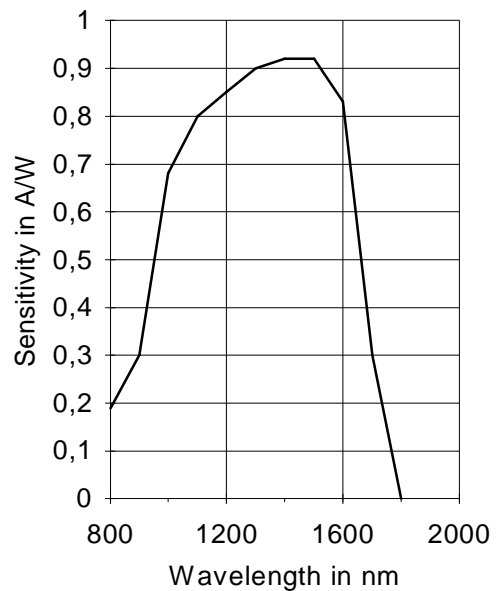

Dark Current $I_R = f(V_R)$
 $I_F = f(V_F)$

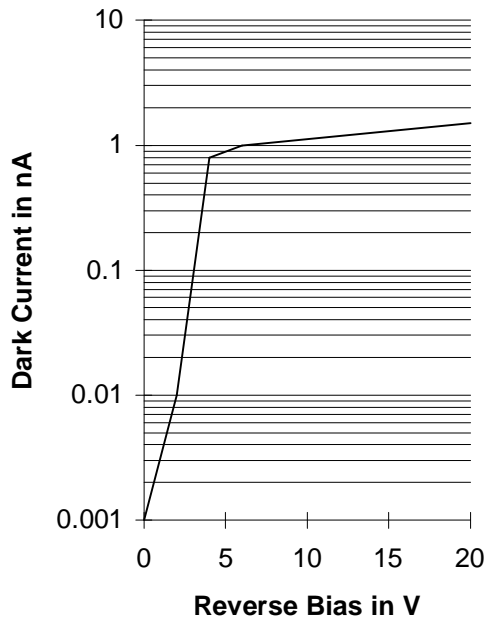

Dark Current $I_R = f(T_A)$
 $\Phi_{port} = 0, V_R = 5 V$

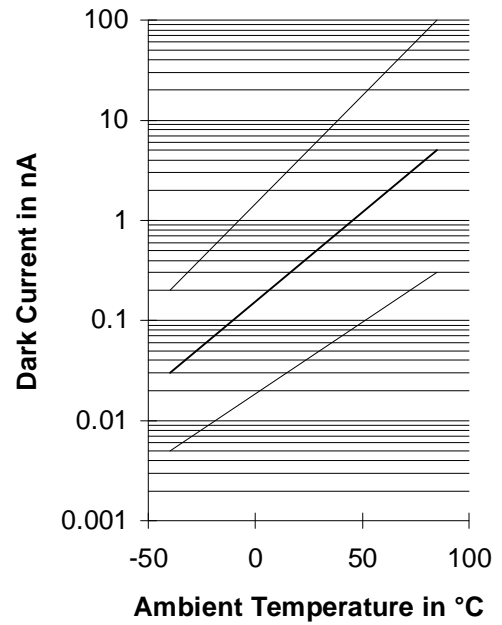

Package Outlines (Dimensions in mm)

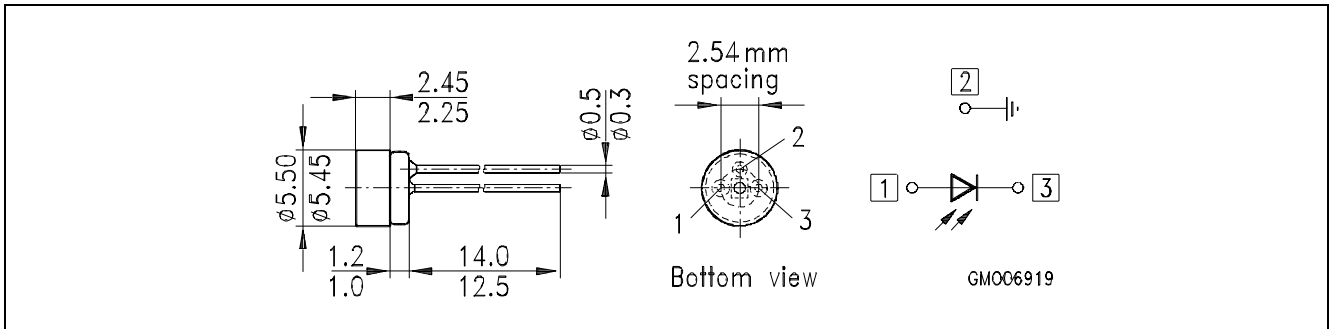

SRD 00212Z