

## SOD523 Plastic-Encapsulate Diodes

### Schottky Rectifier

#### Features

- Small surface mounting type
- Low  $I_R$
- High reliability

#### Applications

- Rectifier

#### Marking

- B

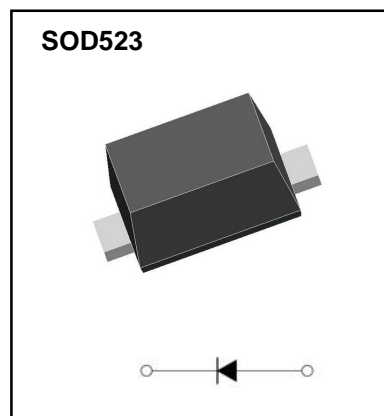

#### Limiting Values (Absolute Maximum Rating)

Parameter	Symbol	Limit	Unit
DC reverse voltage	$V_R$	30	V
Mean rectifying current	$I_O$	200	mA
Non-repetitive Peak Forward Surge Current@t=8.3ms	$I_{FSM}$	1	A
Power dissipation	$P_D$	150	mW
Thermal resistance junction to ambient	$R_{\theta JA}$	667	$^{\circ}C/W$
Junction temperature	$T_j$	125	$^{\circ}C$
Storage temperature	$T_{stg}$	-55~+150	$^{\circ}C$

#### Electrical Characteristics ( $T_a=25^{\circ}C$ Unless otherwise specified)

Parameter	Symbol	Min	Typ	Max	Unit	Conditions
Forward voltage	$V_F$			0.6	V	$I_F=200mA$
Reverse current	$I_R$			1	$\mu A$	$V_R=10V$

# Typical Characteristics

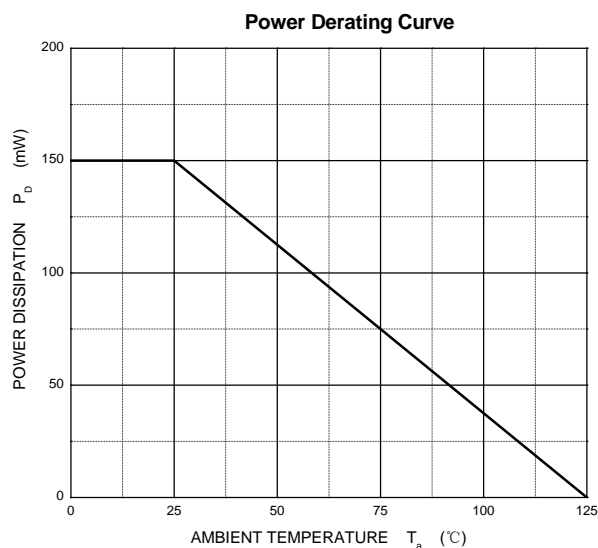
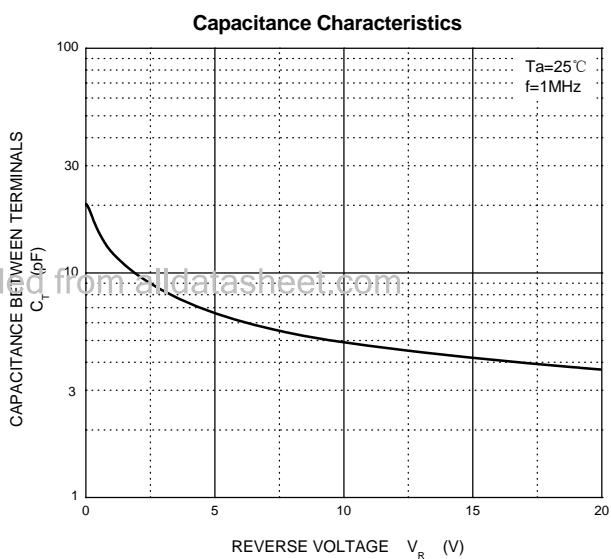
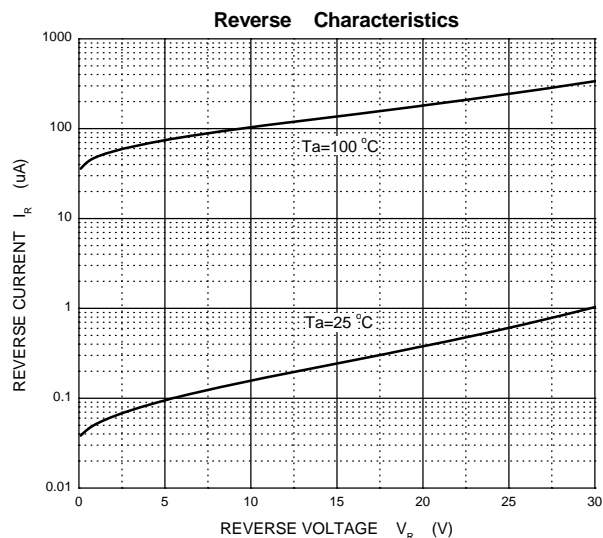
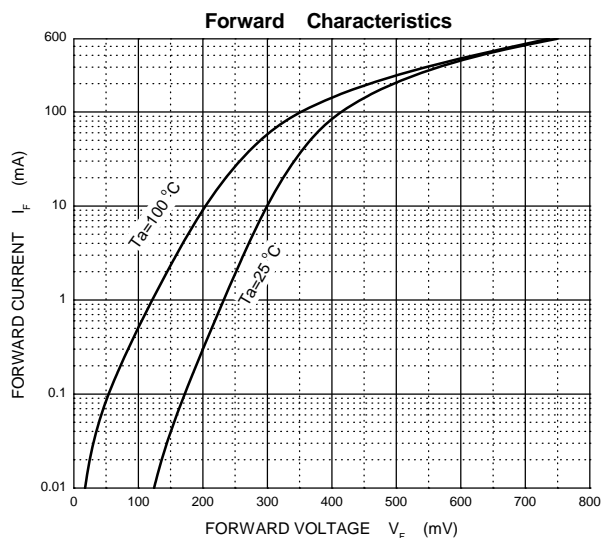

## SOD523 Package Outline Dimensions

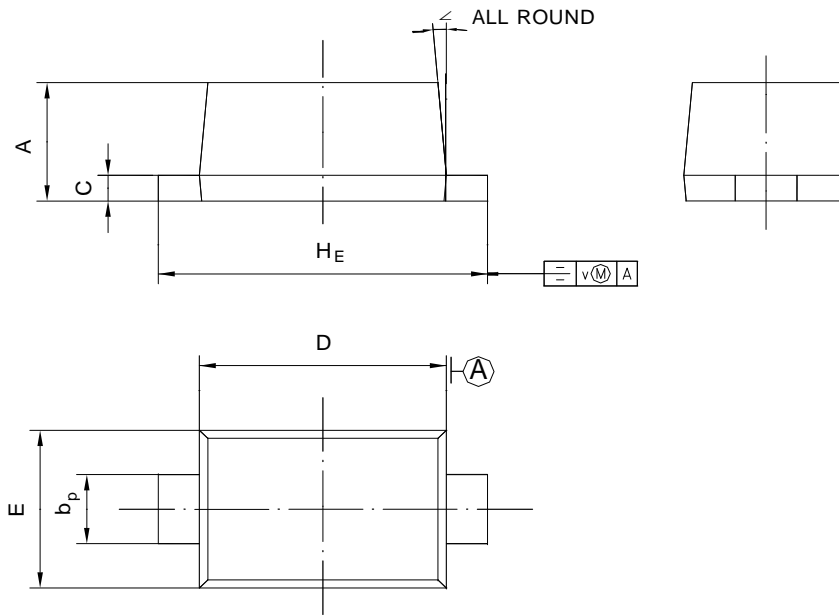

UNIT	A	b <sub>p</sub>	C	D	E	H <sub>E</sub>	V	∠
mm	0.80 0.50	0.4 0.2	0.135 0.100	1.25 1.15	0.85 0.75	1.7 1.5	0.1	5°

Downloaded from alldatasheet.com

## SOD523 Suggested Pad Layout

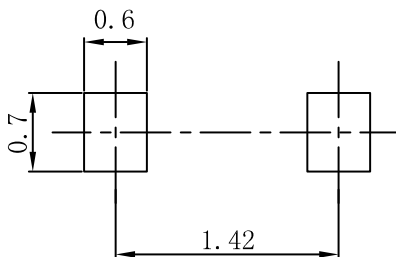

### Note:

1. Controlling dimension: in millimeters.
2. General tolerance:  $\pm 0.05$ mm.
3. The pad layout is for reference purposes only.

### NOTICE

JSHD reserve the right to make modifications, enhancements, improvements, corrections or other changes without further notice to any product herein. JSHD does not assume any liability arising out of the application or use of any product described herein.

# Reel Taping Specifications For Surface Mount Devices-SOD523

## SOD-523 Embossed Carrier Tape

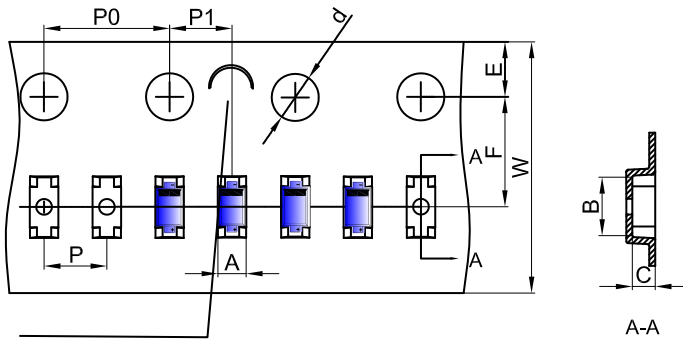

### Packaging Description:

SOD-523 parts are shipped in tape. The carrier tape is made from a dissipative (carbon filled) polycarbonate resin. The cover tape is a multilayer film (Heat Activated Adhesive in nature) primarily composed of polyester film, adhesive layer, sealant, and anti-static sprayed agent. These reeled parts in standard option are shipped with 8,000 units per 7" or 17.8cm diameter reel. The reels are clear in color and is made of polystyrene plastic (anti-static coated).

NOTE: TO CAVE 'C' ON CARRIER TAPE PER 120MM

Dimensions are in millimeter											
Pkg type	A	B	C	d	E	F	P0	P	P1	W	
SOD-523	0.9	1.94	0.73	Ø1.50	1.75	3.50	4.00	2.00	2.00	8.00	

## SOD-523 Tape Leader and Trailer

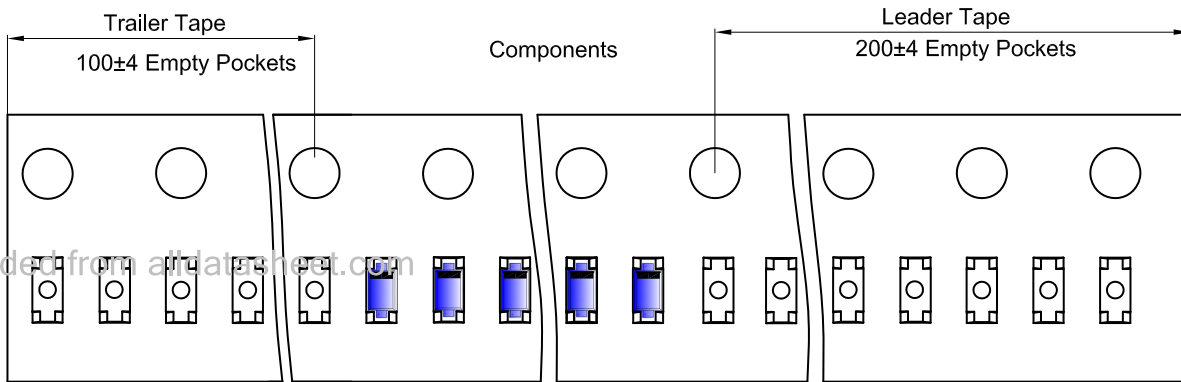

## SOD-523 Reel

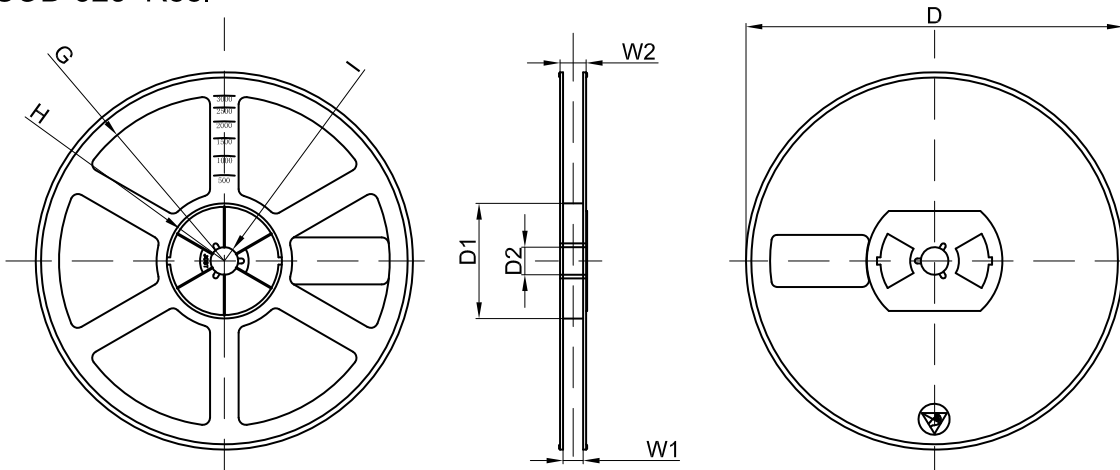

Dimensions are in millimeter								
Reel Option	D	D1	D2	G	H	I	W1	W2
7" Dia	Ø178.00	54.40	13.00	R78.00	R25.60	R6.50	9.50	12.30

REEL	Reel Size	Box	Box Size(mm)	Carton	Carton Size(mm)	G.W.(kg)
8000 pcs	7 inch	120,000 pcs	203×203×195	480,000 pcs	438×438×220	