

STRUTURE AND DIMENSIONS

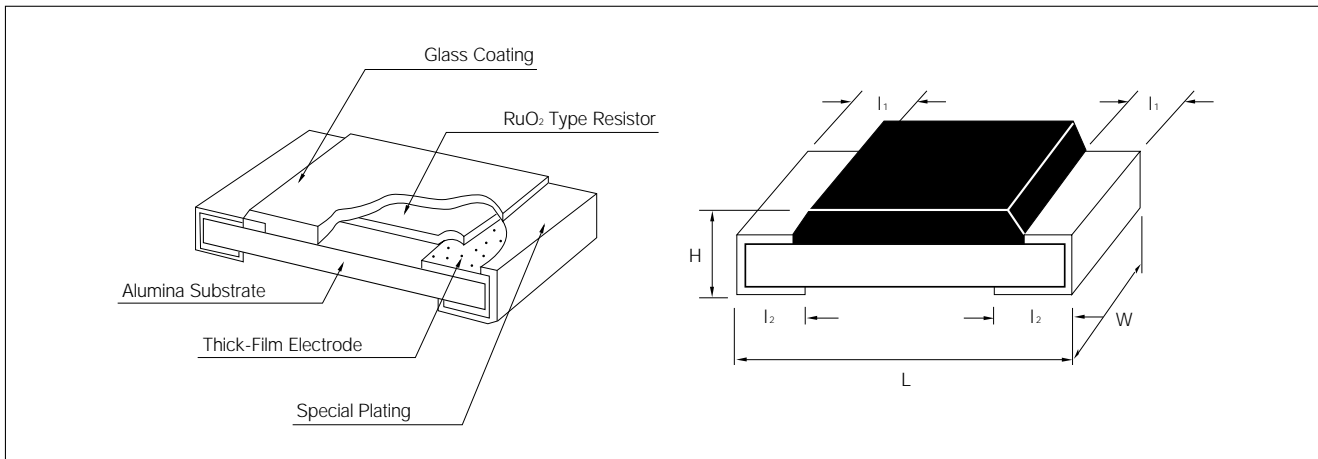

(UNIT : mm)

Type	L	W	H	l ₁	l ₂
RC1005(1/16W)	1.00±0.05	0.50±0.05	0.35±0.05	0.20±0.10	0.25±0.10
RC1608(1/10W)	1.60±0.10	0.80±0.15	0.45±0.10	0.30±0.20	0.35±0.10
RC2012(1/8W)	2.00±0.20	1.25±0.15	0.50±0.10	0.40±0.20	0.35±0.20
RC3216(1/4W)	3.20±0.20	1.60±0.15	0.55±0.10	0.45±0.20	0.40±0.20
RC3225(1/4W)	3.20±0.20	2.55±0.20	0.55±0.10	0.45±0.20	0.40±0.20
RC5025(1/2W)	5.00±0.15	2.50±0.15	0.55±0.15	0.60±0.20	0.60±0.20
RC6432(1W)	6.30±0.15	3.20±0.15	0.55±0.15	0.60±0.20	0.60±0.20

PARTS NUMBERING SYSTEM

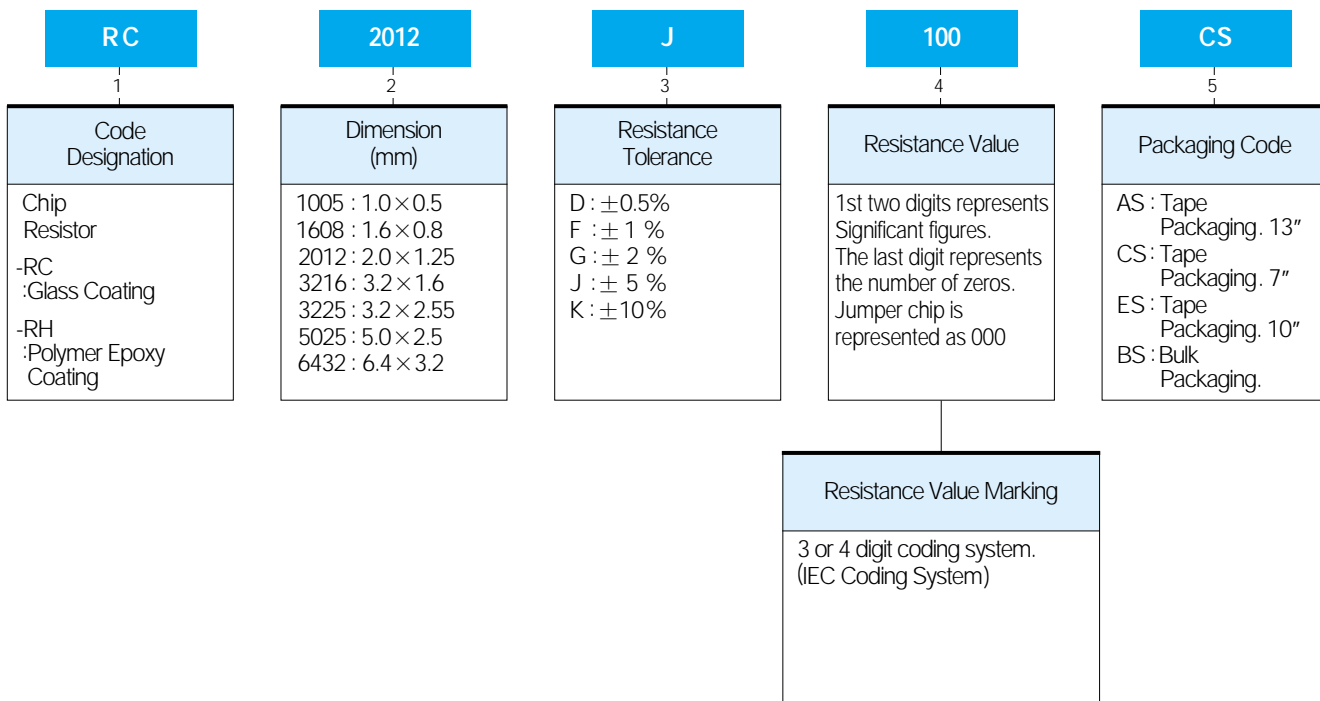

GENERAL SPECIFICATION

Description	RC1005	RC1608	RC2012	RC3216	RC3225	RC5025	RC6432
Power Rating (W) at 70℃	0.063W	0.10W	0.125W	0.25W	0.25W	0.5W	1W
Power Derating Curve	<p>■ 1608, 2012, 3216</p>						
	<p>The rated power is the maximum continuous loading power at 70℃ ambient temperature. For ambient temperature's above 70℃ the loading power follows the above power derating curve.</p>						
Rated Voltage	$\sqrt{\text{Rated power(w)} \times \text{Normal resistance value (W)}}$						
Working Voltage (Max)	50V	50V	50V	150V	200V	200V	200V
Overload Voltage (Max)	100V	100V	100V	300V	400V	400V	400V
Resistance Range	(UNIT: Ω)						
D(±0.5%)	-	10~1M	10~1M	10~1M	10~1M	-	-
F(±1%), G(±2%)	10~1M	10~1M	10~1M	10~1M	10~1M	10~1M	10~1M
J(±5%)	10~1M	1~10M	1~10M	1~10M	1~10M	1~10M	1~10M
K(±10%)	10~1M	1~10M	1~10M	1~10M	1~10M	1~10M	1~10M
Jumper Chip	50 mΩ max						
Operating Temperature Range	-55℃ ~ 125℃ -55℃ ~ 155℃ (For 1608, 2012, 3216)						
Rated Temperature Range	70℃						
Temperature Coefficient	Resistance Tolerance	Resistance Range		Temperature Coefficient			
	J (±5%) K (±10%)	1 Ω ≤ R ≤ 10 MΩ		±(300/200) PPM/℃			
		10 Ω ≤ R < 1 MΩ		±100 PPM/℃			
		1 MΩ ≤ R < 10 MΩ		±3 00 PPM/℃			
G (±2%) F (±1%) D (±0.5%)	10 Ω ≤ R < 1 MΩ		±100 PPM/℃				

* Please specify wattage when power rathing at the mark(*) is required at the time of ordering.

SPECIFICATION IN THE LOW RESISTANCE RANGE

Description	RC2012	RC3216	RC3225	RC5025	RC6432
Power Rating (W) at 70℃	0.10W	0.125W *0.25W	0.25W	0.5W	1W

Power Derating Curve	<p style="text-align: center;">POWER Derating Curve</p> <p>The rated power is the maximum continuous loading power at 70℃ ambient temperature. For ambient temperature's above 70℃ the loading power follows the above power derating curve.</p>
----------------------	---

Rated Voltage	$\sqrt{\text{Rated power(w)} \times \text{Normal resistance value (}\Omega\text{)}}$				
Working Voltage(Max)	50V	100V	200V	200V	200V
Overload Voltage(Max)	100V	200V	400V	400V	400V

Resistance range	(UNIT : Ω)				
F(±1%)	0.2 Ω ~ 0.91 Ω (E24 Series)				
G(±2%)					
J(±5%)					
K(±10%)					

Operating temperature range	-55℃ ~ 125℃				
-----------------------------	-------------	--	--	--	--

Rated Ambient Temperature	70℃				
---------------------------	-----	--	--	--	--

Temperature Coefficient	Resistance Tolerance	Resistance Range	Temperature Coefficient
	F(±1%)	0.2 Ω ≤ R ≤ 1 Ω	±200 PPM/℃
	G(±2%)	0.2 Ω ≤ R ≤ 1 Ω	±200PPM/℃
	J(±5%)	0.2 Ω ≤ R ≤ 1 Ω	±(600/300)PPM/℃
	K(±10%)	0.2 Ω ≤ R ≤ 1 Ω	±(600/300)PPM/℃

* Please specify wattage when power rathing at the mark(*) is required at the time of ordering.

TRIMMABLE CHIP RESISTOR

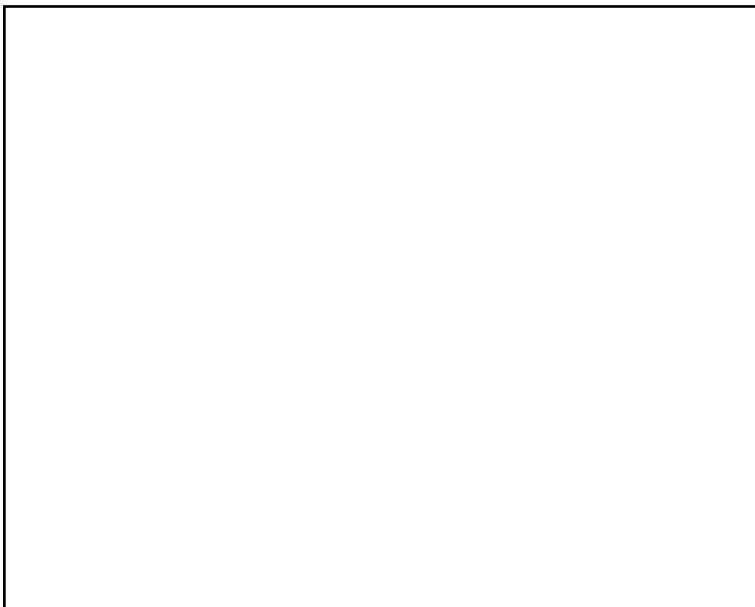

FEATURES

- Available in use of function trimming.
- Compatible with both wave and reflow soldering.
- Highly stable in auto-placement surface mounting application.
- Excellent electrical characteristic.

DIMENSIONS

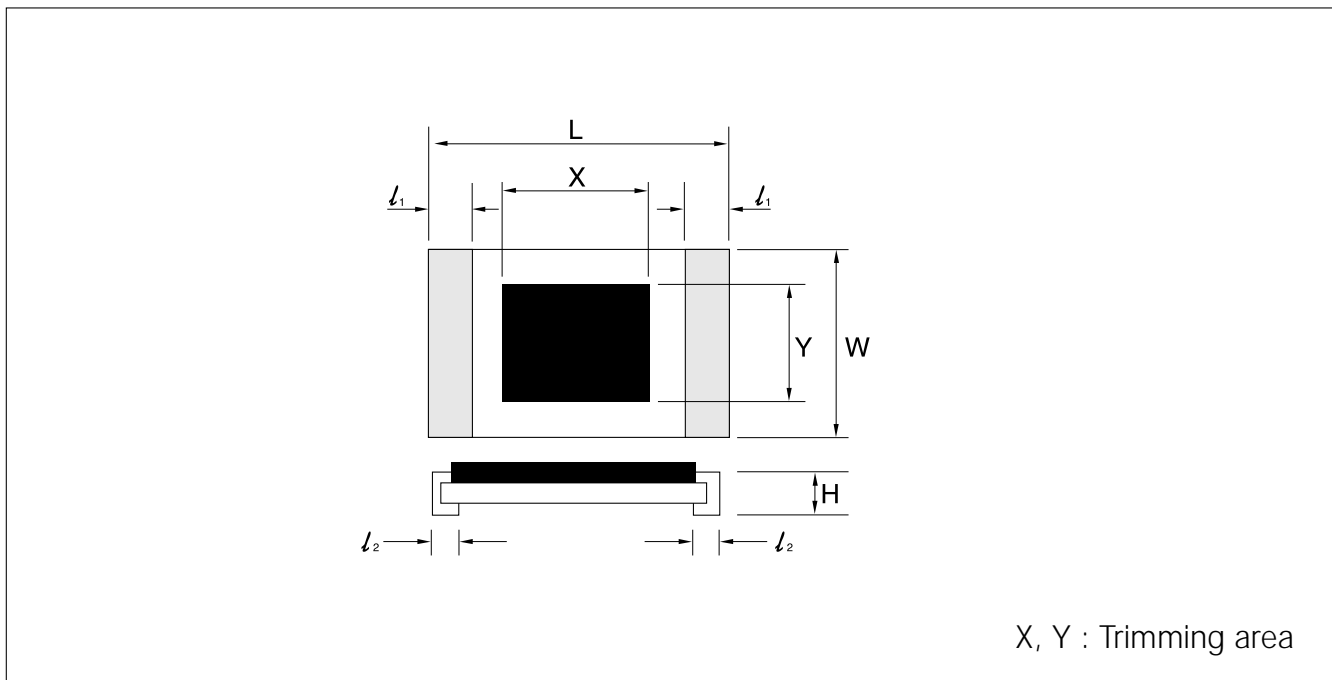

(Unit : mm)

TYPE	L	W	H	l ₁	l ₂	X	Y
RT1608	1.60±0.10	0.80±0.15	0.45±0.10	0.30±0.20	0.35±0.10	0.50±0.10	0.40±0.10
RT2012	2.00±0.20	1.25±0.15	0.50±0.10	0.40±0.20	0.35±0.20	0.70±0.10	0.60±0.10
RT3216	3.20±0.20	1.60±0.15	0.55±0.10	0.45±0.20	0.40±0.20	1.30±0.10	1.00±0.10

GENERAL SPECIFICATION

RT	2012	M	100	CS
Code Designation	Dimension (mm)	Resistance Tolerance	Resistance Value	Packaging Code
Trimmable Chip Resistor	1608:1.6×0.8 2012:2.0×1.25 3216:3.2×1.6	K = ±10%	E12 Series E6 Series (IEC Coding system)	CS : Tape Packaging GS : Bulk Packaging

* RT:DIP Type(Major)

RATING

Type	Power Rating	Working Voltage (MAX)	Over load Voltage (MAX)	Resistance Range	Operating Temperature Range	Rating Ambient Temperature	Temperature Coefficient
RT1608	1/16W	50 V	100 V	1~10 MΩ	-55℃ ~ +125℃	+70℃	±200ppm/℃ ±300ppm/℃
RT2012	1/10W	100 V	200 V	1~10 MΩ			
RT3216	1/8W	200 V	400 V	1~10 MΩ			
	1/4W	200 V	400 V	1~10 MΩ			

PACKAGING

- The Chip Network Resistors can be supplied with packaged carrier tape for effective use in SMD machine.
- All Reel taping specifications are in accordance with EIAJ RC-1009.
- Standard Quantity :

7 inch reel	5,000/1 reel
13 inch reel	20,000/1 reel

- Chip Resistor for Bulk shall be in the polyethylene bag and Quantity of the Chip Resistors in bag is determined by customer orders.(Standard Quantity : 5,000EA)

R/R TYPE CHIP NET WORK RESISTOR

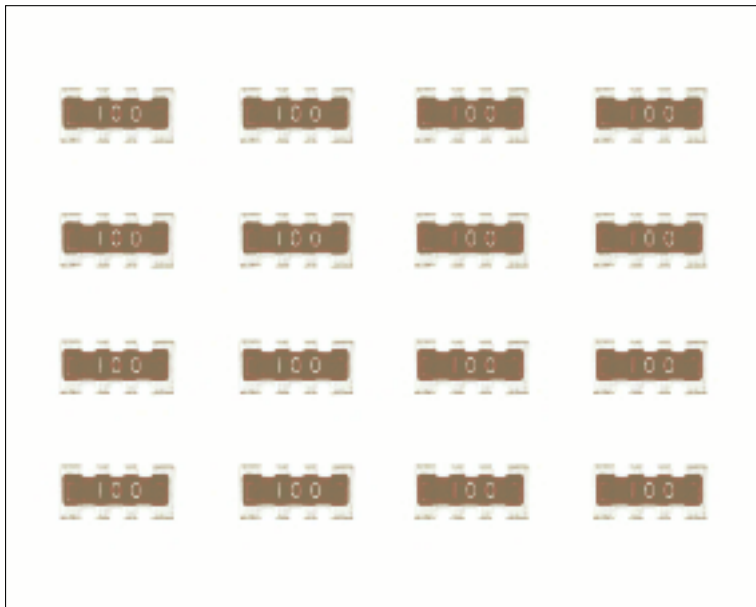

FEATURES

- High density mouting
- Improvement of placement efficiency.
- Automatic placement.

DIMENSIONS

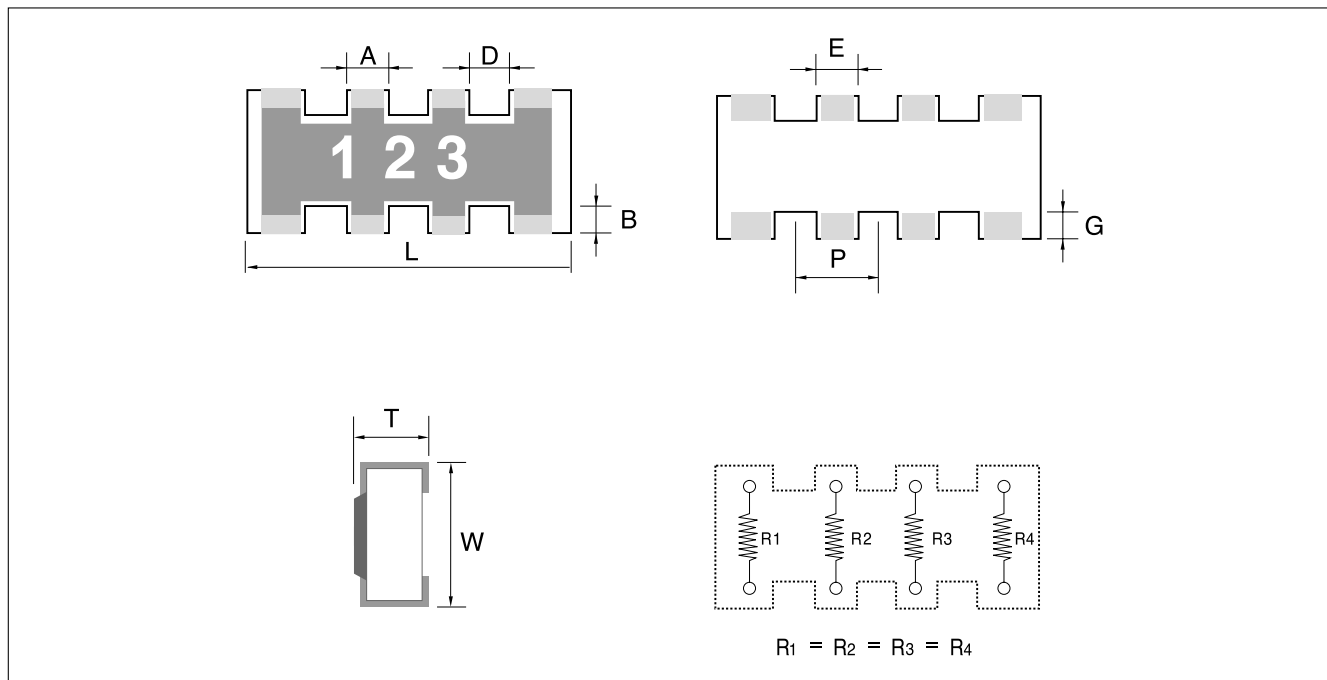

UNIT [mm]

TYPE	L	W	T	A	D	B	P	E	G
RR164P	3.2±0.2	1.5±0.2	0.5±0.2	0.5±0.2	Max 0.16	0.25±0.2	0.8±0.15	0.5±0.2	0.25±0.2

R/R TYPE CHIP NET WORK RESISTOR

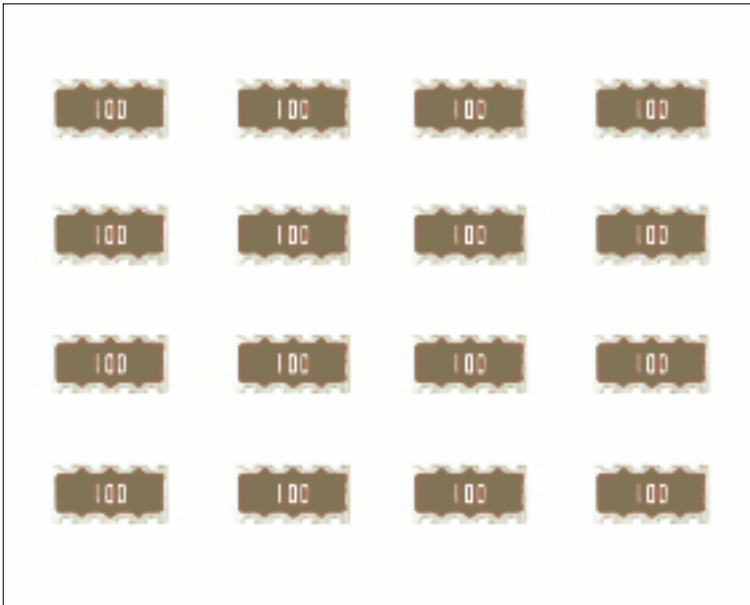

FEATURES

- High density mouting
- Improvement of placement efficiency.
- Automatic placement.

DIMENSIONS

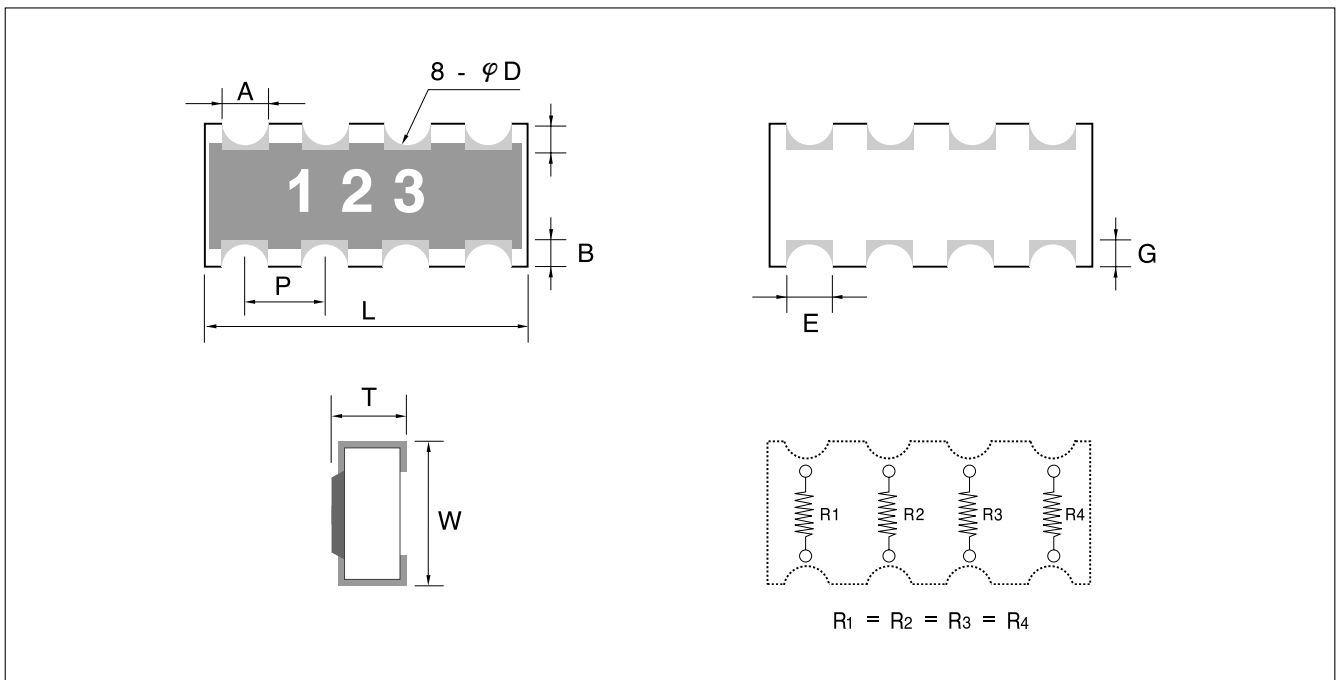

UNIT [mm]

TYPE	L	W	T	A	D	B	P	E	G
RN164P	3.2±0.2	1.6±0.2	0.6±0.1	0.45±0.1	0.3±0.1	0.3±0.2	0.8±0.1	0.45±0.1	0.40±0.15

PARTS NUMBERING SYSTEM

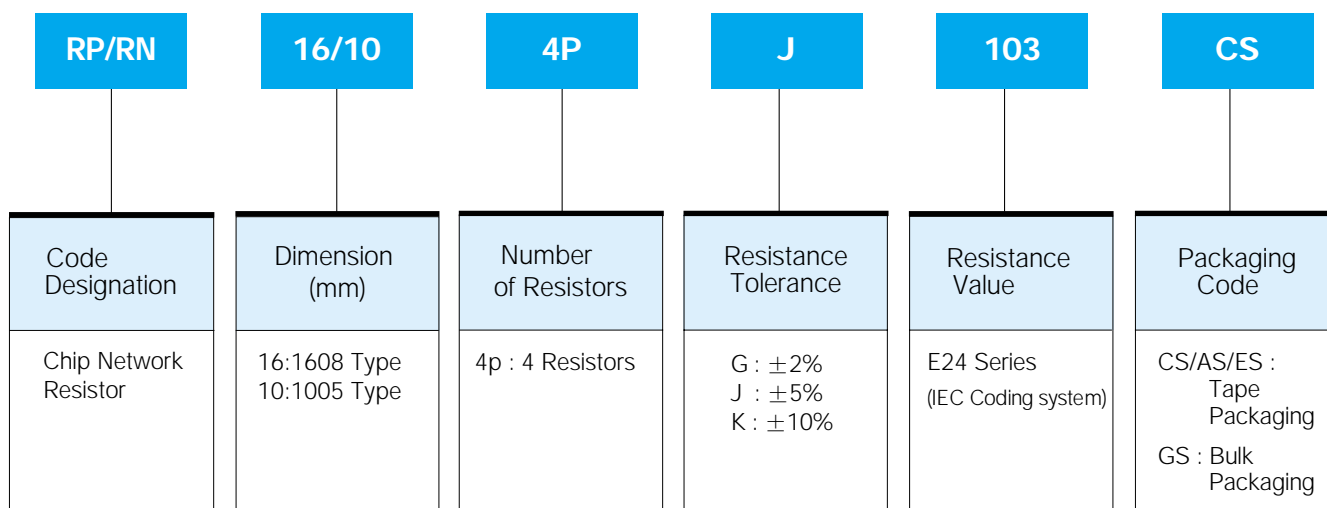

- * RP, RR: Dip Type(Convex Type)
- * RN: Through Hole Type(Concave Type)

RATING

Type	Power Rating	Working Voltage (MAX)	Overload Voltage (MAX)	Resistance Range	Operting Temperature Range	Rating Ambient Temperature	Temperature Coefficient
RP104P	1/16W	50V	100V	10~1M	-55 ~ 125°C	+70°C	±250 PPM/°C
RP164P	1/16W	50V	100V	10~1M	-55 ~ 125°C	+70°C	±250 PPM/°C
RN164P	1/16W	50V	100V	10~1M	-55 ~ 125°C	+70°C	±250 PPM/°C

PACKAGING

- The Chip Network Resistors can be supplied packaged carrier tape for effective use SMD machine.
- All Reel taping specifications are in accordance with EIAJ RC-1009.
- Standard Quantity :

7 inch reel	5,000EA/1 reel
10 inch reel	10,000EA/1 reel
13 inch reel	20,000EA/1 reel(15,000EA/1reel)

- Chip Network Resistor for Bulk shall be in the plastic case and Quantity of the Chip Resistors in bag is determined by customer orders.(Standard Quantity : 5,000EA)

CHARACTERISTICS PERFORMANCE

ELECTRICAL CHARACTERISTICS

Item	Specification	Test Method														
Direct Current Resistance	Within the regulated resistance tolerance. Jumper chip $\leq 50 M\Omega$	Applying time: within 5 sec <table border="1"> <thead> <tr> <th>Resistance range(Ω)</th> <th>Max test voltage(V)</th> </tr> </thead> <tbody> <tr> <td>$R < 100$</td> <td>0.3</td> </tr> <tr> <td>$100 \leq R < 1K$</td> <td>1.0</td> </tr> <tr> <td>$1K \leq R < 10K$</td> <td>3</td> </tr> <tr> <td>$10K \leq R < 100K$</td> <td>10</td> </tr> <tr> <td>$100K \leq R < 1M$</td> <td>25</td> </tr> <tr> <td>$1M \leq R$</td> <td>50</td> </tr> </tbody> </table>	Resistance range(Ω)	Max test voltage(V)	$R < 100$	0.3	$100 \leq R < 1K$	1.0	$1K \leq R < 10K$	3	$10K \leq R < 100K$	10	$100K \leq R < 1M$	25	$1M \leq R$	50
Resistance range(Ω)	Max test voltage(V)															
$R < 100$	0.3															
$100 \leq R < 1K$	1.0															
$1K \leq R < 10K$	3															
$10K \leq R < 100K$	10															
$100K \leq R < 1M$	25															
$1M \leq R$	50															
T.C.R(Resistance Temperature Characteristic)	$1 \leq R < 10$: $+300ppm/^{\circ}C$ $-200ppm/^{\circ}C$ $10 \leq R < 1M$: $\pm 100ppm/^{\circ}C$ $1M \leq R \leq 10M$: $\pm 300ppm/^{\circ}C$	Test temperature($^{\circ}C$) (20) \rightarrow (-55) \rightarrow (20) \rightarrow (125) \rightarrow (20) T.C.R(ppm/ $^{\circ}C$) = $(R-R_0)/R_0 \times 1/(T-T_0) \times 10^6$ $T = 20(^{\circ}C)$ T = Test temperature($^{\circ}C$) R_0 = Resistance at room temperature(Ω) R = Resistance at T(Ω)														
Short-time Overload	ΔR : $\leq \pm(1\%+0.1 \Omega)$ of the initial value Visual : No evidence of mechanical damage Jumper chip : $\leq 50 M\Omega$	Apply 2.5 times rated voltage for 5sec. Wait 30 minutes at room temperature and measure the resistance value.														
Intermittent Overload	ΔR : $\leq \pm(3\%+0.1 \Omega)$ of the initial value Visual : No evidence of mechanical damage Jumper chip : $\leq 50 M\Omega$	Perform 10,000 cycles at 2.5 times RCW or the Max. over load voltage ON(2.5 times rated volage) : 1 sec OFF : 25 sec Have stabilization time of 30 minutes without loading and measure resistance.														
Dielectric withstanding Voltage	No evidence of mechanical damage.	Apply AC 500V for 1 minute. 1005(1/16W), 1608(1/16W):Apply AC 100V for 1 minute														
Insulation Resistance	Over the 1000 $M\Omega$	Apply DC 500V for 1 minute. 1005(1/16W), 1608(1/16W):Apply DC 100V for 1 minute														

MECHANICAL CHARACTERISTICS

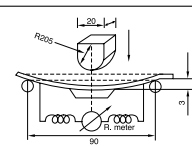
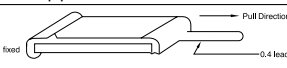
Item	Specification	Test Method												
Solderability	Coverage : $\geq 95\%$ each termination. Visual : No crack of termination parts and ceramic exposure of surface by melting	After immersing in flux. dip into the $235 \pm 5^{\circ}C$ molten solder for 2 ± 0.5 sec Solder : S63A(KSD 6704) Flux : ROSIN(KSM 2951) Flux is the composition of ROSIN and the methanol Weight rate of ROSIN is about 25%												
Bending Test	ΔR : $\leq \pm(0.5\%+0.05 \Omega)$ of the initial value Visual : No evidence of mechanical damage.	After soldering resistor on the PCB, 3mm of bending shall be applied for 10 sec. Material of PCB : Glass Epoxy Thickness : 1.6mm Measure resistance during load application 												
Terminal Strength	Load pull : $\geq 0.5kg$ 1005(1/16W), 1608(1/16W) $\geq 0.3kg$	pull Direction fixed 0.4 lead 												
Terminal Strength	ΔR : $\leq \pm(1\%+0.05 \Omega)$ of the initial value Visual : No evidence of mechanical damage.	Immerse in molten solder at $260 \pm 5^{\circ}C$ for 10 ± 1 sec. Preheat and soldering Procedure <table border="1"> <thead> <tr> <th>Temperature($^{\circ}C$)</th> <th>Time(sec)</th> </tr> </thead> <tbody> <tr> <td>80 - 100</td> <td>120</td> </tr> <tr> <td>150 - 180</td> <td>120</td> </tr> <tr> <td>260 + 5</td> <td>10</td> </tr> <tr> <td>150 - 180</td> <td>60</td> </tr> <tr> <td>80 - 100</td> <td>60</td> </tr> </tbody> </table> Solder : S63A(SSD 6704) Flux : The composition of ROSIN (KSM295)25% and methanol (KSM 1658)75%	Temperature($^{\circ}C$)	Time(sec)	80 - 100	120	150 - 180	120	260 + 5	10	150 - 180	60	80 - 100	60
Temperature($^{\circ}C$)	Time(sec)													
80 - 100	120													
150 - 180	120													
260 + 5	10													
150 - 180	60													
80 - 100	60													
Anti-Vibration Test	ΔR : $\leq \pm(1\%+0.05 \Omega)$ of the initial value Visual : No evidence of mechanical damage.	2 hours each in X, Y, and Z axis (total 6 hours) 10 to 55 Hz sweep in 1 minute amplitude.												

THICK FILM CHIP RESISTORS

ELECTRICAL CHARACTERISTICS

Item	Specification	Test Method															
Low Temperature exposure	$\Delta R : \leq \pm(3\%+0.1 \Omega)$ of the initial value. Visual : No evidence of mechanical damage.	Dwell in -55°C chamber without loading for 1000 ± 12 hours Dwell for 60 minutes at Room temperature and Measure resistance value.															
Temperature Cycle	$\Delta R : \leq \pm(1\%+0.1 \Omega)$ of the initial value. Visual : No evidence of mechanical damage.	Perform 100Cycles as follows. <table border="1"> <thead> <tr> <th>No.</th> <th>Temperature($^{\circ}\text{C}$)</th> <th>Time(min)</th> </tr> </thead> <tbody> <tr> <td>1</td> <td>-55 ± 3</td> <td>30</td> </tr> <tr> <td>2</td> <td>20 ± 3</td> <td>15</td> </tr> <tr> <td>3</td> <td>125 ± 3</td> <td>30</td> </tr> <tr> <td>4</td> <td>20 ± 3</td> <td>15</td> </tr> </tbody> </table>	No.	Temperature($^{\circ}\text{C}$)	Time(min)	1	-55 ± 3	30	2	20 ± 3	15	3	125 ± 3	30	4	20 ± 3	15
No.	Temperature($^{\circ}\text{C}$)	Time(min)															
1	-55 ± 3	30															
2	20 ± 3	15															
3	125 ± 3	30															
4	20 ± 3	15															
Load Life in Moisture	At $R < 10 \Omega$ $\Delta R : \leq \pm 5\%$ At $R < 1 \text{ M}\Omega$ $\Delta R : \leq \pm(3\% + 0.1 \Omega)$ At $R \geq 1 \text{ M}\Omega$ $\Delta R : \leq \pm 5\%$ Visual : No evidence of mechanical damage.	Temperature : $40 \pm 2^{\circ}\text{C}$ RH : 90-95% Applying rated voltage for 90 minutes "ON" and 30minutes"OFF" Duration : 1000 hours Dwell in Room temperature for 1 hour and measure resistance value.															
Load Life in high Temperature	At $R < 10 \Omega$ $\Delta R : \leq \pm 5\%$ At $R < 1 \text{ M}\Omega$ $\Delta R : \leq \pm(3\% + 0.1 \Omega)$ At $R > 1 \text{ M}\Omega$ $\Delta R : \leq \pm 5\%$	Temperature : $70 \pm 3^{\circ}\text{C}$ at rated voltage. Applying rated voltage for 90 minutes "ON" and 30minutes"OFF" Duration : 1000 hours Dwell in Room temperature for 1 hour and measure resistance value.															
Heat Resistance (High Temperature Exposure)	$\Delta R : \leq \pm(3\%+0.1 \Omega)$ of the initial value. Visual : No evidence of mechanical damage.	Dwell in $125 \pm 3^{\circ}\text{C}$ chamber without loading for 1000 ± 12 hours Dwell in Room temperature for 1 hour and measure resistance value.															

PACKAGING

- The Chip Resistor can be supplied with packaged carrier tape for effective use in SMD machine.
- All Reel taping specifications are in accordance with EIAJ RC-1009.
- Standard Quantity :

REEL SIZE	1005	1608, 2012, 3216	5025, 6432
7 inch reel	10,000EA/1 reel	5,000EA/1 reel	4,000EA/1 reel
10 inch reel	-	10,000EA/1 reel	-
13 inch reel	40,000EA/1 reel	20,000EA/1 reel	15,000EA/1 reel

- Chip Resistor for Bulk shall be in the plastic Quantity of the Chip Resistors in bag is determined by custom orders.(Standard Quantity : 5,000EA)

CARRIER TAPE DIMENSIONS

►This is applied to 1005 series.

(Unit: mm)

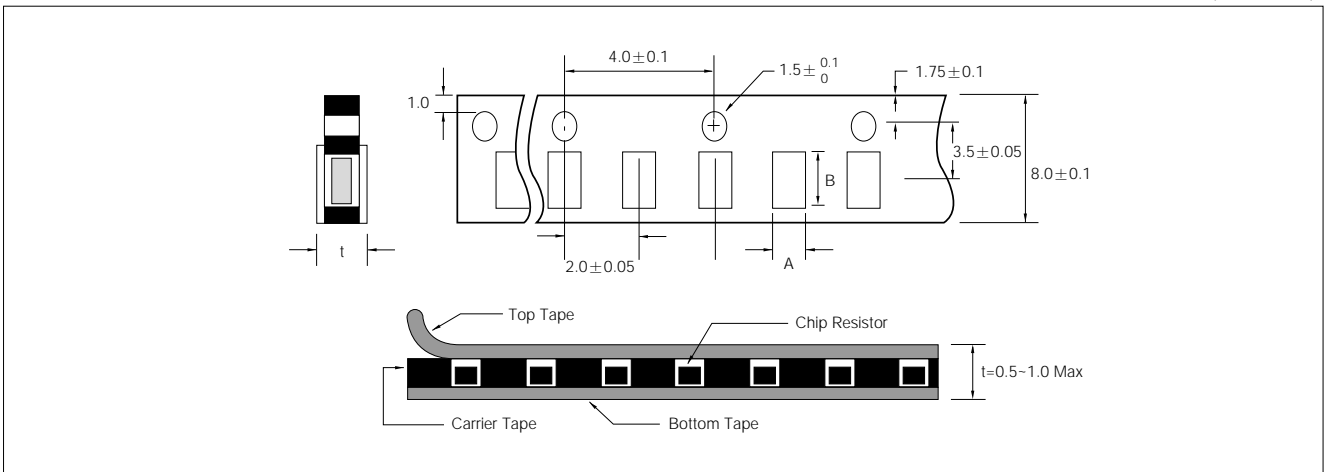

►This is applied to 5025, 6432 series.

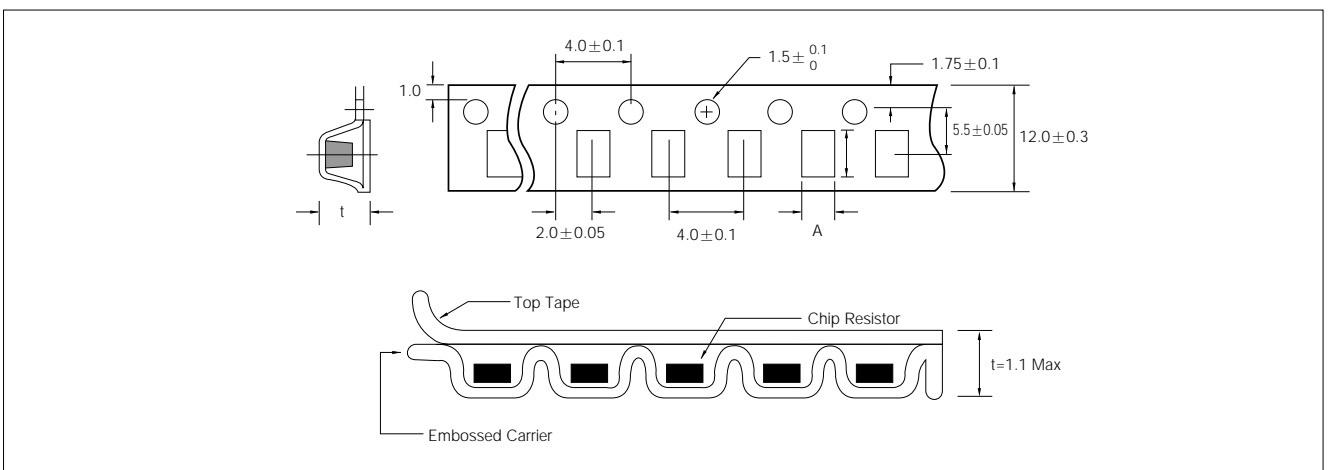

• WINDOW DIMENSIONS

(mm)

SIGN.	ITEM	RC 1005 (1/16W)	RC 5025 (1/2W)	RC 6432 (1W)
A		0.7±0.10	2.80	3.50±0.10
B		1.20±0.10	5.32±0.20	6.75±0.10
t		0.5(MAX)	1.10(MAX)	1.10(MAX)

