

NIR-Enhanced, Single Pixel Silicon Photomultiplier (SiPM)



ON Semiconductor®

www.onsemi.com

Product Preview

RD-Series SiPM Sensors

The MicroRD family of sensors are a range of Silicon Photomultipliers (SiPM) that provide market-leading sensitivity in the red and NIR region of the electromagnetic spectrum. The MicroRD SiPMs feature high responsivity, fast signal response and a low temperature coefficient of operating voltage, all achieved at a low bias voltage. The sensor is packaged in a compact and robust MLP (micro lead frame) package that is suitable for reflow solder processes. The product is designed for high-volume, automotive applications and will be qualified to the AEC-Q102 standard.

SiPM sensors are an improvement over avalanche photodiodes (APD) and PIN diodes due to their high gain and single photon sensitivity. For LiDAR applications this enables the detection of low reflectivity targets at very long distances.

It is strongly recommended that those new to SiPM sensors consult the [Introduction to Silicon Photomultipliers](#) application note.

Evaluation boards (SMA and SMTPA boards – see pages 4–5) are also available for these products.

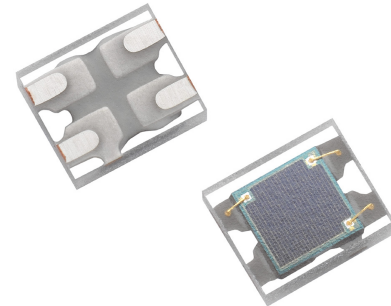

ORDERING INFORMATION

See detailed ordering and shipping information on page 6 of this data sheet.

KEY SENSOR AND PACKAGE SPECIFICATIONS

Parameter	Value			Unit	Comment
Silicon Process	RD				NIR enhanced
Number of Pixels	Single pixel				
Active Area	1 × 1			mm	
Microcell Size	10	20	35	μm	
Number of Microcells per Pixel	4370	1620	625		
Microcell Fill Factor	44	65	77	%	
Package Size	1.5 × 1.8 × 0.65			mm	MLP Package (W × L × H)
Output Type	Analog				Standard and Fast output per pixel

This document contains information on a product under development. ON Semiconductor reserves the right to change or discontinue this product without notice.

RD-Series SiPM Sensors

PERFORMANCE SPECIFICATIONS

Typical values are measured at 21°C. Minimum and Maximum values (when available) will take into account operation over the full temperature range of -40°C to 105°C. All measurements made at Vop (see biasing table below). All timing measurements acquired using a MicroRD-SMA EVB.

Parameter	Microcell Variant	Min	Typ	Max	Unit	Comment
PDE @ 905 nm	10 μm	–	6.0	–	%	
	20 μm	–	9.1	–	%	
	35 μm	–	10.2	–	%	
Dark Count Rate	10 μm	–	1	–	Mcps	
	20 μm	–	800	–	kcps	
	35 μm	–	550	–	kcps	
Optical Crosstalk	10 μm	–	25	–	%	
	20 μm	–	25	–	%	
	35 μm	–	25	–	%	
Gain	10 μm	–	0.7×10^6	–		
	20 μm	–	0.9×10^6	–		
	35 μm	–	1.9×10^6	–		
Afterpulsing Probability	10 μm	–	13	–	%	0.5 Photoelectron level
	20 μm	–	3	–	%	
	35 μm	–	1	–	%	
Microcell Recovery Time Constant	10 μm	–	18	–	ns	RC time constant
	20 μm	–	21	–	ns	
	35 μm	–	55	–	ns	
Microcell Rise Time	10 μm	–	1.9	–	ns	
	20 μm	–	1.8	–	ns	
	35 μm	–	0.46	–	ns	
Fast Output Pulse Width	10 μm	–	1.3	–	ns	FWHM
	20 μm	–	1.5	–	ns	
	35 μm	–	2.6	–	ns	
Fast Output Rise Time	10 μm	–	240	–	ps	
	20 μm	–	350	–	ps	
	35 μm	–	530	–	ps	

BIAS PARAMETERS

Parameter	Microcell Size	Min	Typ	Max	Unit	Comment
Breakdown Voltage (Vbr) *	10 μm	–	21.9	–	V	
	20 μm	–	22.4	–	V	
	35 μm	–	22.4	–	V	
Over Voltage (Vov)	10 μm	–	12.0	–	V	Typical values recommended for operation and used for characterization
	20 μm	–	7.0	–	V	
	35 μm	–	3.2	–	V	
Operating Bias	10 μm	Vop = Vbr + Vov				
	20 μm					
	35 μm					
Temperature Coefficient of Vbr		Contact sensl_questions@onsemi.com				

*The breakdown voltage (Vbr) is defined as the value of the voltage intercept of a straight line fit to a plot of \sqrt{I} vs V, where I is the current and V is the bias voltage.

RD-Series SiPM Sensors

ABSOLUTE MAXIMUM RATINGS

Parameter	Value	Unit	Comment
Maximum Current	3	mA	At typical Vop
Maximum Storage Temperature	125	°C	
Operating Temperature Range	-40 to +105	°C	Ambient temperature

Stresses exceeding those listed in the Maximum Ratings table may damage the device. If any of these limits are exceeded, device functionality should not be assumed, damage may occur and reliability may be affected.

PACKAGE SPECIFICATIONS

Parameter	Value	Unit	Comment
ESD-HBM	TBD		
ESD-CDM	TBD		
θ_{JC}	46	°C/W	
θ_{JA}	731	°C/W	
MSL	MSL 3 for tape and reel (TR delivery option) MSL 4 for cut tape (TR1 delivery option)		

PIN ASSIGNMENT

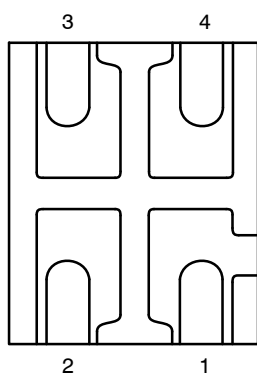

BOTTOM VIEW

Pin Number	Pin Assignment
1	Anode
2	Fast Output
3	Cathode
4	No Connect*

*The 'No Connect' pins are electrically isolated and should be soldered to a ground (or bias) plane to help with heat dissipation.

APPLICATION ADVICE

- For biasing and readout, please consult the [AND9782/D](#) Application note
- For handling and soldering advice, please consult the [AND9788/D](#) Application note

RD-Series SiPM Sensors

SMA BIASING BOARD (MicroRD-SMA-100XX)

The MicroRD-SMA is a printed circuit board (PCB) that can facilitate the evaluation of the MicroRD MLP sensors. The board has three female SMA connectors for connecting the bias voltage, the standard output from the cathode, and the fast output signal. The output signals can be connected directly to a 50 Ω -terminated oscilloscope for viewing. The biasing and output signal tracks are laid out in such a way as to preserve the fast timing characteristics of the sensor.

The MicroRD-SMA is recommended for users who require a plug-and-play set-up to quickly evaluate MicroRD sensors with optimum timing performance. The board also allows the signal from the cathode-anode readout to be observed at the same time as the fast output. The outputs can be connected directly to the oscilloscope or measurement device, but external preamplification may be required to boost the signal. The table below lists the SMA board connections. The SMA board electrical schematics are available to download in the [Board Reference Design](#) document.

MicroRD-SMA-100XX	
Output	Function
Vbias	Negative bias input (anode)
Fout	Fast output
Sout	Standard output (cathode)

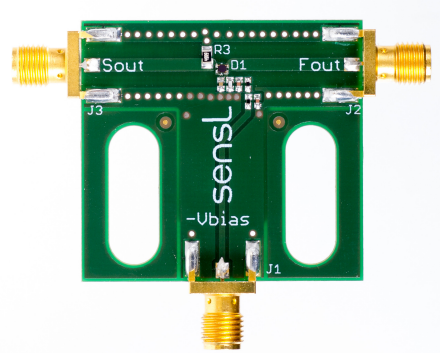

Figure 1. SMA Biasing Board

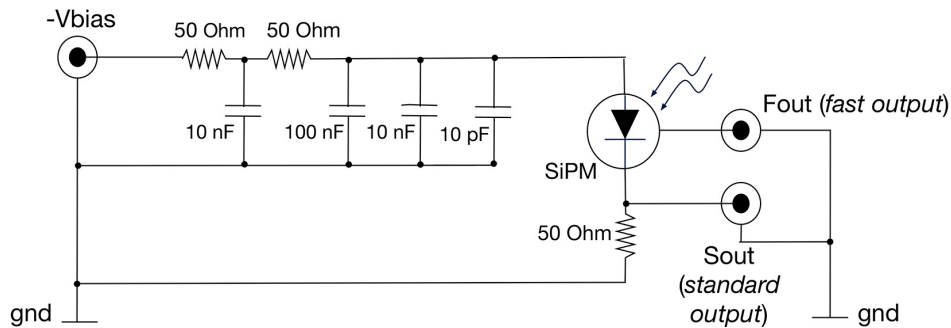

Figure 2. Schematic of SMA Biasing Board

RD-Series SiPM Sensors

PIN ADAPTER BOARD (MicroRD-SMTPA-100XX)

The Pin Adapter board (SMTPA) is a small PCB board that houses the SiPM sensor and has through-hole pins to allow its use with standard sockets or probe clips. This product is useful for those needing a quick way to evaluate the MLP-packaged sensor without the need for specialist surface-mount soldering. While this is a 'quick fix' suitable for many evaluations, it should be noted that the timing performance from this board will not be optimized and if the best possible timing performance is required, the MicroRD-SMA-100XX is recommended. The SMTPA circuit schematic is shown below. Please consult the [Biasing and Readout](#) Application Note for further information on biasing. The SMTPA board electrical schematics are available to download in the [Board Reference Design](#) document.

MicroRD-SMTPA-100XX	
Pin. No.	Function
1	Anode
2	Fast output
3	Cathode
4	Ground
5	Ground

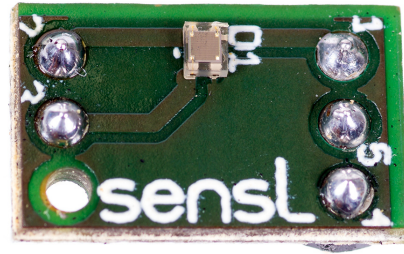

Figure 3. Pin Adapter Board

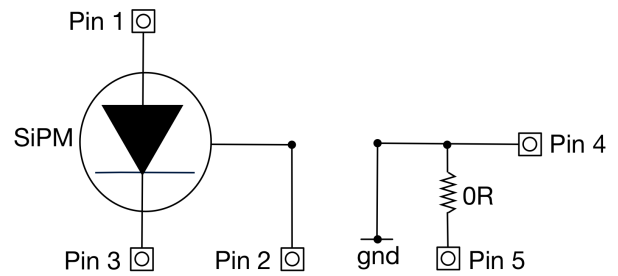

Figure 4. Schematic of Pin Adapter Board

RD-Series SiPM Sensors

ORDERING INFORMATION

ORDERING INFORMATION

Part Number	Microcell Size	Product Description	Shipping Format*
MicroRD-10010-MLP-TR	10 μm	1 mm \times 1 mm RD-Series Silicon Photomultiplier pixel (NIR enhanced) with fast output, packaged in MLP	Tape and Reel
MicroRD-10010-MLP-TR1			Cut Tape
MicroRD-10010-MLP-TR-E		Unqualified prototype part of the MicroRD-10010-MLP	Depends upon Quantity Ordered
MicroRD-SMA-10010-GEVB		MicroRD-10010-MLP sensor mounted onto a PCB with SMA connectors for bias and outputs.	ESD Package
MicroRD-SMTPA-10010-GEVB		MicroRD-10010-MLP packaged sensor mounted onto a pin adapter board.	ESD Package
MicroRD-10020-MLP-TR	20 μm	1 mm \times 1 mm RD-Series Silicon Photomultiplier pixel (NIR enhanced) with fast output, packaged in MLP	Tape and Reel
MicroRD-10020-MLP-TR1			Cut Tape
MicroRD-10020-MLP-TR-E		Unqualified prototype part of the MicroRD-10020-MLP	Depends upon Quantity Ordered
MicroRD-SMA-10020-GEVB		MicroRD-10020-MLP sensor mounted onto a PCB with SMA connectors for bias and outputs.	ESD Package
MicroRD-SMTPA-10020-GEVB		MicroRD-10020-MLP packaged sensor mounted onto a pin adapter board.	ESD Package
MicroRD-10035-MLP-TR	35 μm	1 mm \times 1 mm RD-Series Silicon Photomultiplier pixel (NIR enhanced) with fast output, packaged in MLP	Tape and Reel
MicroRD-10035-MLP-TR1			Cut Tape
MicroRD-10035-MLP-TR-E		Unqualified prototype part of the MicroRD-10035-MLP	Depends upon Quantity Ordered
MicroRD-SMA-10035-GEVB		MicroRD-10035-MLP sensor mounted onto a PCB with SMA connectors for bias and outputs.	ESD Package
MicroRD-SMTPA-10035-GEVB		MicroRD-10035-MLP packaged sensor mounted onto a pin adapter board.	ESD Package

*For information on tape and reel specifications, please contact sensl_questions@onsemi.com.

RD-Series SiPM Sensors

PACKAGE DIMENSIONS

CWDFN4 1.5x1.8, 0.8P
CASE 512AL
ISSUE O

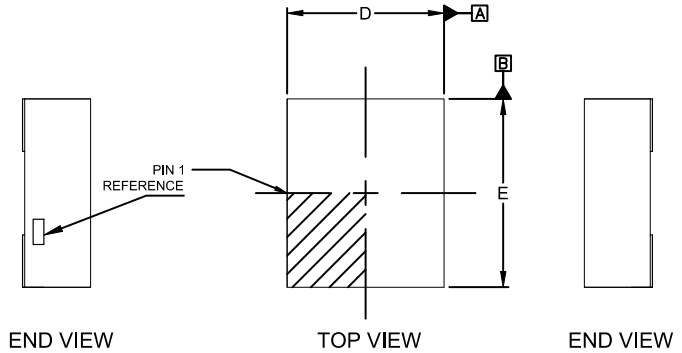

NOTES:

1. DIMENSIONING AND TOLERANCING PER ASME Y14.5M, 2009.
2. CONTROLLING DIMENSION: MILLIMETERS

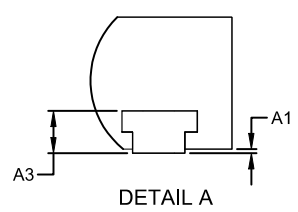

DIM	MILLIMETERS		
	MIN.	NOM.	MAX.
A	0.60	0.65	0.70
A1	0.00	--	0.05
A3	0.20 REF		
b	0.20	0.25	0.30
D	1.40	1.50	1.60
E	1.70	1.80	1.90
e	0.80 BSC		
L	0.465	0.515	0.565

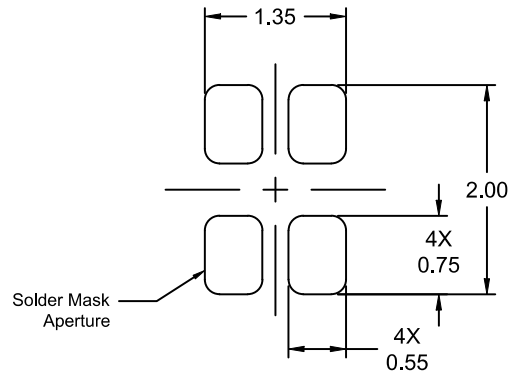
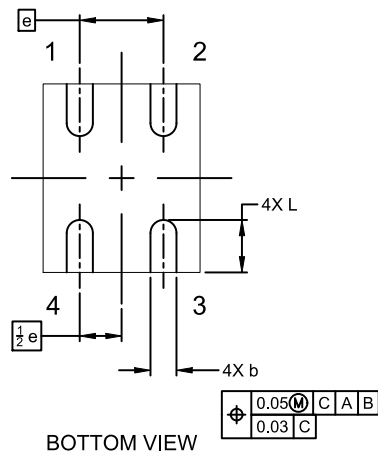
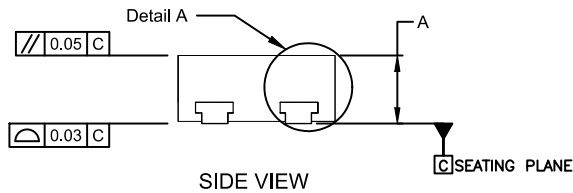

RECOMMENDED MOUNTING FOOTPRINT*

* For additional information on our Pb-Free strategy and soldering details, please download the ON Semiconductor Soldering and Mounting Techniques Reference Manual, SOLDERRM/D.

⌀	0.05	Ⓞ	C	A	B
	0.03		C		

RD-Series SiPM Sensors

EVALUATION BOARD DIMENSIONS (MicroRD-SMA-100XX-GEVB)

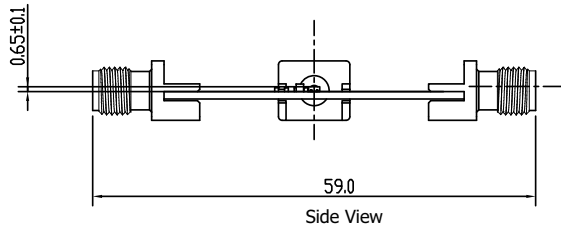
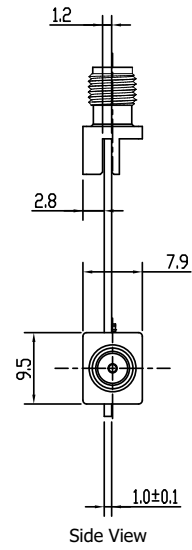
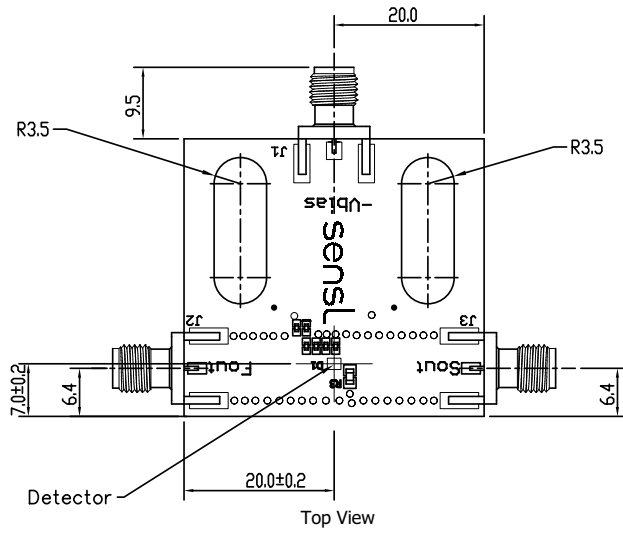

SMA Assignments	
SMA ID	Description
-VBias	Bias Voltage
Sout	Standard Output
Fout	Fast Output

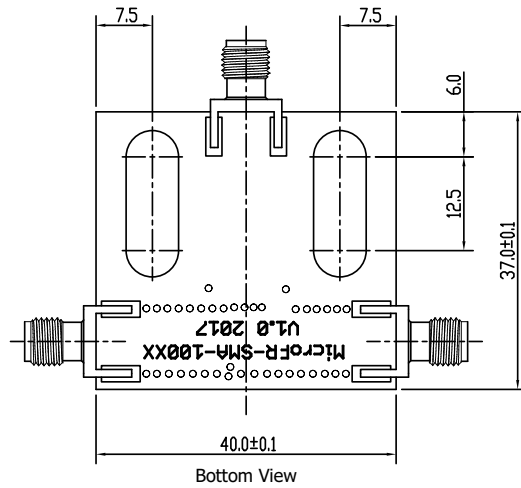

RD-Series SiPM Sensors

EVALUATION BOARD DIMENSIONS (MicroRD-SMTPA-100XX-GEVB)

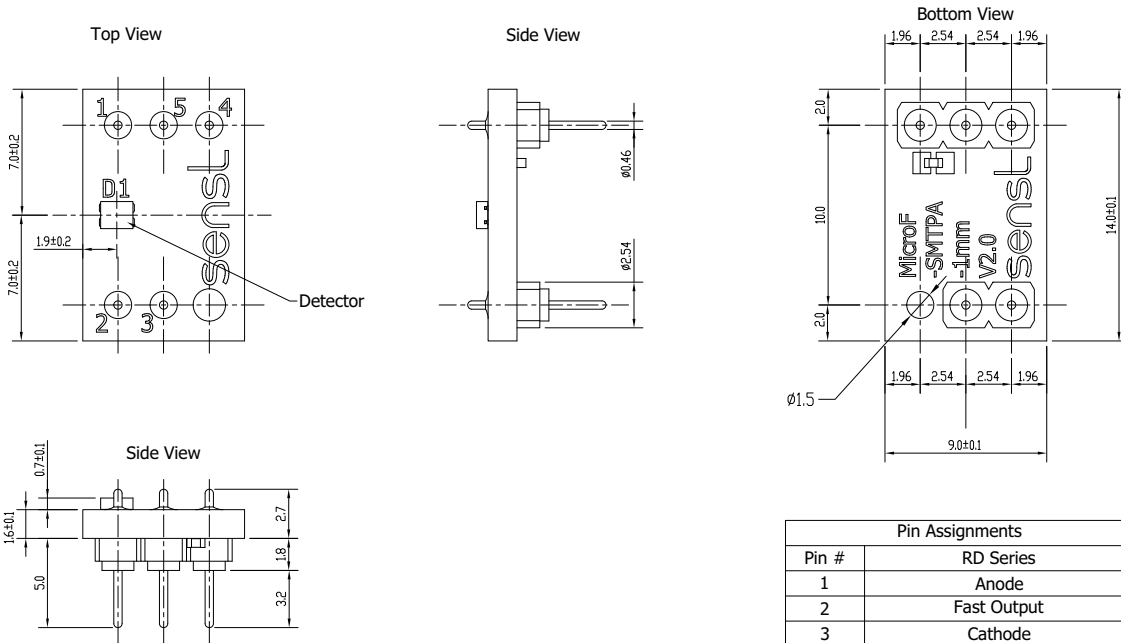

Pin Assignments	
Pin #	RD Series
1	Anode
2	Fast Output
3	Cathode
4	PCB Ground
5	Jumper to PCB Ground (0 Ohm)

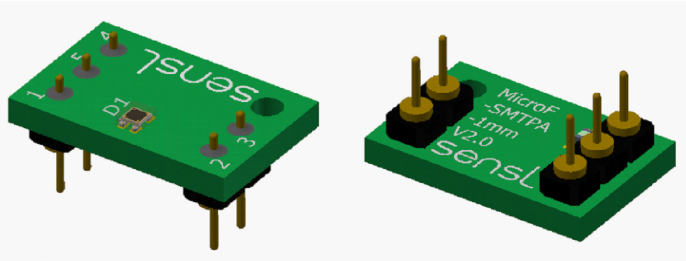

Top View Bottom View

SensL is a registered trademark of Semiconductor Components Industries, LLC (SCILLC) or its subsidiaries in the United States and/or other countries.

ON Semiconductor and are trademarks of Semiconductor Components Industries, LLC dba ON Semiconductor or its subsidiaries in the United States and/or other countries. ON Semiconductor owns the rights to a number of patents, trademarks, copyrights, trade secrets, and other intellectual property. A listing of ON Semiconductor's product/patent coverage may be accessed at www.onsemi.com/site/pdf/Patent-Marking.pdf. ON Semiconductor reserves the right to make changes without further notice to any products herein. ON Semiconductor makes no warranty, representation or guarantee regarding the suitability of its products for any particular purpose, nor does ON Semiconductor assume any liability arising out of the application or use of any product or circuit, and specifically disclaims any and all liability, including without limitation special, consequential or incidental damages. Buyer is responsible for its products and applications using ON Semiconductor products, including compliance with all laws, regulations and safety requirements or standards, regardless of any support or applications information provided by ON Semiconductor. "Typical" parameters which may be provided in ON Semiconductor data sheets and/or specifications can and do vary in different applications and actual performance may vary over time. All operating parameters, including "Typicals" must be validated for each customer application by customer's technical experts. ON Semiconductor does not convey any license under its patent rights nor the rights of others. ON Semiconductor products are not designed, intended, or authorized for use as a critical component in life support systems or any FDA Class 3 medical devices or medical devices with a same or similar classification in a foreign jurisdiction or any devices intended for implantation in the human body. Should Buyer purchase or use ON Semiconductor products for any such unintended or unauthorized application, Buyer shall indemnify and hold ON Semiconductor and its officers, employees, subsidiaries, affiliates, and distributors harmless against all claims, costs, damages, and expenses, and reasonable attorney fees arising out of, directly or indirectly, any claim of personal injury or death associated with such unintended or unauthorized use, even if such claim alleges that ON Semiconductor was negligent regarding the design or manufacture of the part. ON Semiconductor is an Equal Opportunity/Affirmative Action Employer. This literature is subject to all applicable copyright laws and is not for resale in any manner.

PUBLICATION ORDERING INFORMATION

LITERATURE FULFILLMENT:
Email Requests to: orderlit@onsemi.com

ON Semiconductor Website: www.onsemi.com

TECHNICAL SUPPORT
North American Technical Support:
Voice Mail: 1 800-282-9855 Toll Free USA/Canada
Phone: 011 421 33 790 2910

Europe, Middle East and Africa Technical Support:
Phone: 00421 33 790 2910
For additional information, please contact your local Sales Representative