

**Application**

- Low-loss SAW component
- Low amplitude ripple
- Sharp rejections at both out-bands
- Usable passband 19.80 MHz

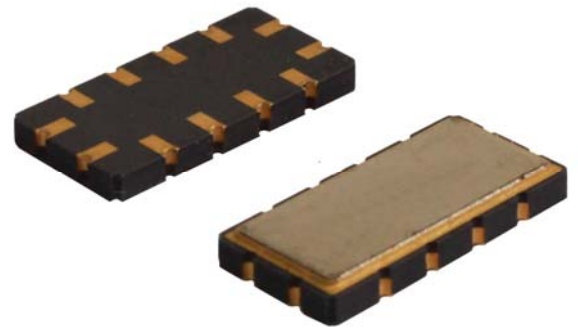

**Features**

- Ceramic Package for **Surface Mounted Technology (SMT)**
- **RoHS** compatible
- Package size 13.30x6.50x1.80mm<sup>3</sup>
- Package Code QCC12
- **Electrostatic Sensitive Device(ESD)**

**Package Dimensions (Unit: mm)**

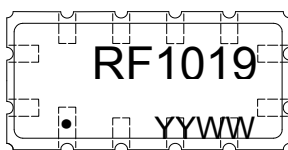
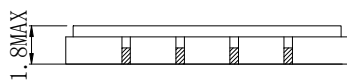
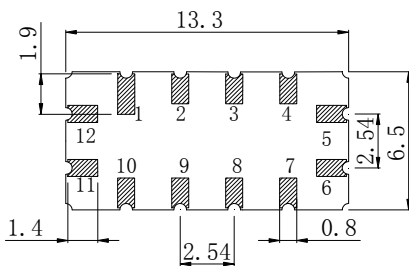

**Pin Configuration**

Pin No.	Description
11	Input
5	Output
1,2,3,4,7,8,9,10	Case Ground
6,12	To be Grounded

**Marking Description**

RF	R	Manufacturer
	F	SAW Filter
1019	Part Number	
●	Pin 1	
YYWW	Year Code & Week Code	

**Test Circuit (Bottom View)**

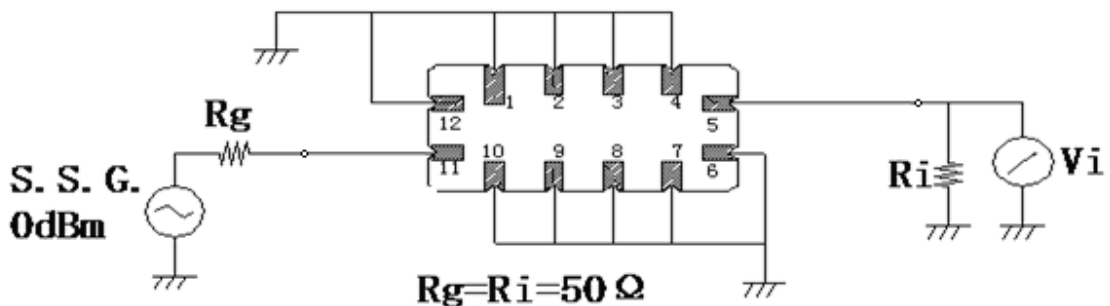

\*Fig: If the products produced in 06<sup>th</sup> week of 2015, The year code & week code is 1506.

**Performance****Maximum Rating**

Item		Value	Unit
DC Voltage	$V_{DC}$	3	V
Operation Temperature	T	-40 ~ +85	°C
Storage Temperature	$T_{stg}$	-55 ~ +125	°C
RF Power Dissipation	P	15	dBm

**Electronic Characteristics**

Test Temperature:  $25^{\circ}\text{C} \pm 2^{\circ}\text{C}$

Terminating source impedance:  $50\Omega$

Terminating load impedance:  $50\Omega$

Item		Minimum	Typical	Maximum	Unit
Center Frequency	fc		120.00		MHz
Insertion Loss	@120.00MHz IL		23.5	25.0	dB
Amplitude Ripple (p-p)	$F_o \pm 9.9\text{MHz}$ $\Delta\alpha$		0.6	1.0	dB
1 dB Bandwidth	@120.00MHz $BW_{1dB}$	20.55	20.75		MHz
3 dB Bandwidth	@120.00MHz $BW_{3dB}$		21.31		MHz
40 dB Bandwidth	@120.00MHz $BW_{40dB}$		23.36	23.5	MHz
Group Delay Ripple	$F_o \pm 9.9\text{MHz}$ GDR		20.0	60.0	ns
Absolute Group Delay	@120.00MHz GDR		1.277		us
Absolute Attenuation					
	20.00 – 105.00 MHz	45.0	50.0		dB
	135.00 – 230.00 MHz	45.0	50.0		dB

Frequency Characteristics

Frequency Response

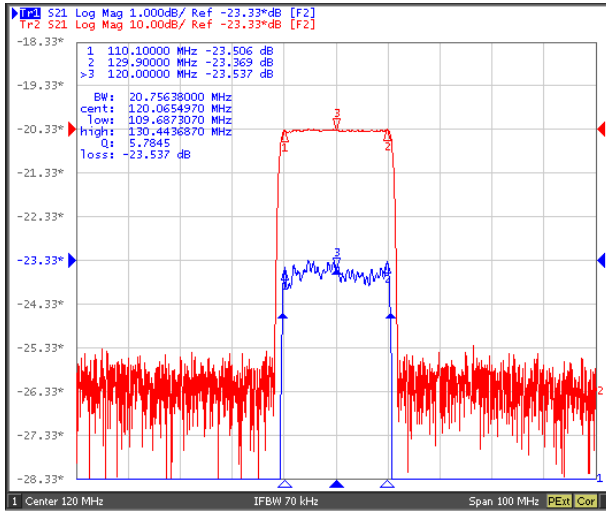

Frequency Response (wideband)

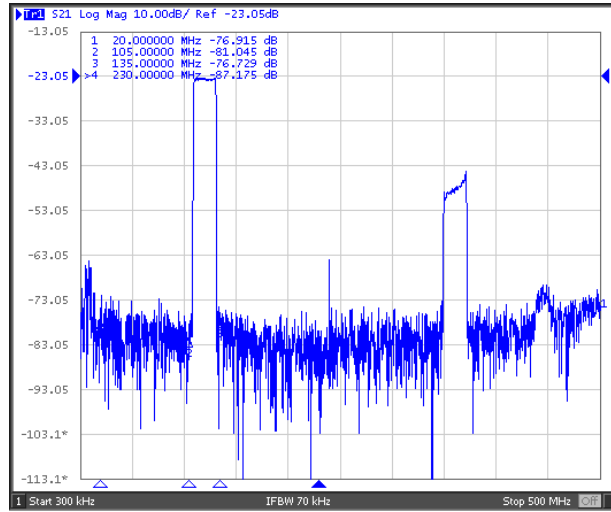

Delay Ripple & S11 VSWR

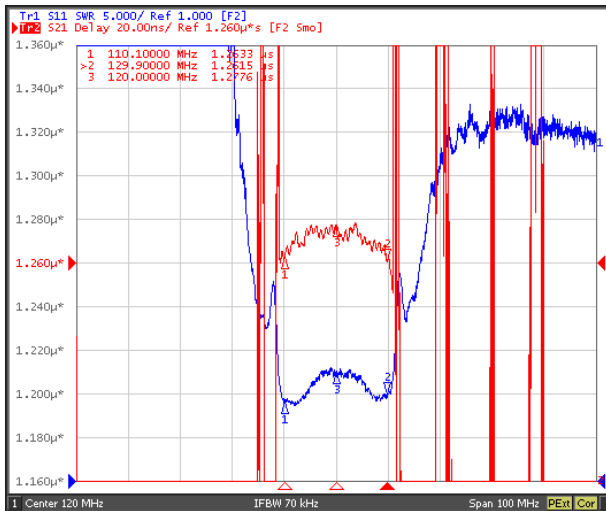

Phase Linearity & S22 VSWR

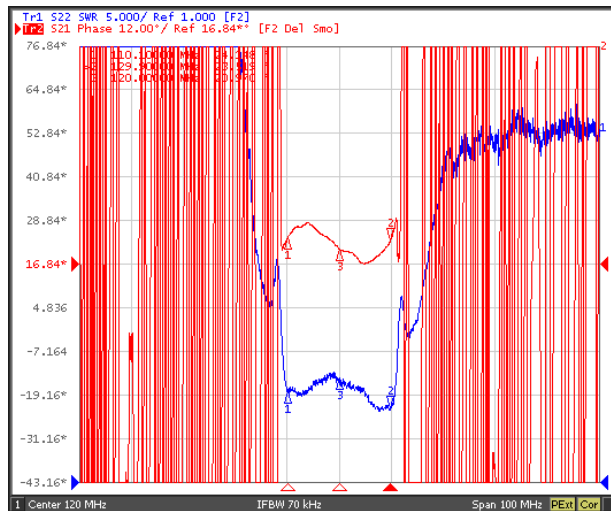

S11 Smith Chart

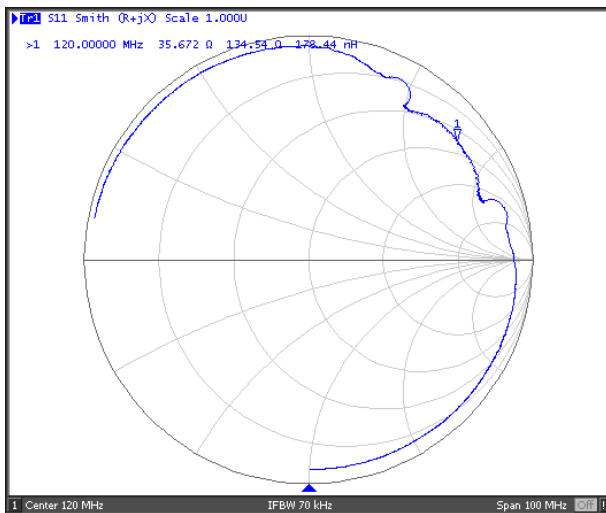

S22 Smith Chart

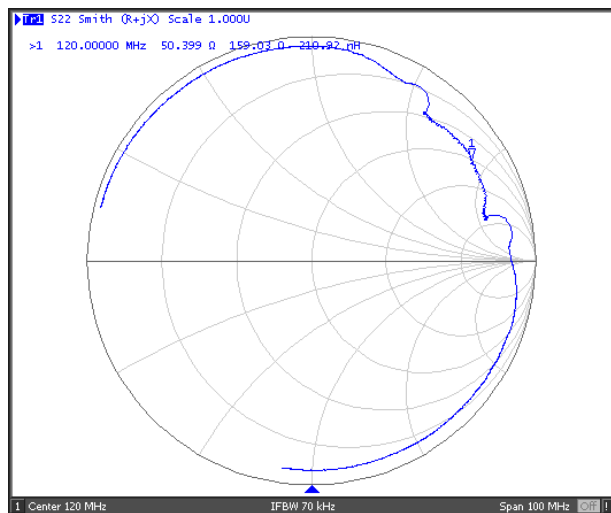



**Notes**

1. As a result of the particularity of inner structure of SAW products, it easy to be breakdown by electrostatic, so we should pay attention to **ESD protect** in the test.
2. **Static voltage** between signal load and ground may cause deterioration and destruction of the component. Please avoid static voltage.
3. **Ultrasonic cleaning** may cause deterioration and destruction of the component. Please avoid ultrasonic cleaning.
4. Only leads of component may **be soldered**. Please avoid soldering another part of component.
5. There is a close relationship between the device's performance and **matching network**. The specifications of this device are based on the test circuit shown above. L and C values may change depending on board layout. Values shown are intended as a guide only.