

Absolute Maximum Ratings

Parameter	Rating	Unit
Supply Voltage	-0.5 to +6.0	V _{DC}
Bias Voltage, V _{BIAS}	≤V _{CC}	V _{DC}
Input RF Level	+15 (see note)	dBm
Current Drain, I _{CC}	32	mA
Operating Ambient Temperature	-40 to +85	°C
Storage Temperature	-40 to +150	°C



Caution! ESD sensitive device.

RF Micro Devices believes the furnished information is correct and accurate at the time of this printing. However, RF Micro Devices reserves the right to make changes to its products without notice. RF Micro Devices does not assume responsibility for the use of the described product(s).

NOTE: Exceeding any one or a combination of the above maximum rating limits may cause permanent damage. Input RF transients to +15dBm will not harm the device. For sustained operation at inputs ≥+10dBm, a small dropping resistor of 10Ω is recommended in series with the V_{CC}.

Parameter	Specification			Unit	Condition
	Min.	Typ.	Max.		
Overall					25°C, V _{CC} =3.3V, at typical frequencies unless otherwise specified
Supply Voltage (V _{CC})	2.7	3.3	5.0	V	V _{BIAS} =0V
Bias Voltage (V _{BIAS})	2.7	3.3	5.0	V	
RF Frequency Range		800 to 2500		MHz	
Power Down Current			10	μA	
Isolation		23		dB	
Current Drain (LNA)	8	14	19	mA	
Current Drain (Driver)	12	18	23	mA	
IP2		55		dBm	
Cellular Low Noise Amplifier					I _{CC} =10mA
Frequency	820	880	960	MHz	
Gain	19.5	21.5	23.5	dB	
Noise Figure		1.1	1.3	dB	
IIP3	-3	-1		dBm	
IP1dB	-13	-11		dBm	
Input VSWR		2.0	2.5		
Output VSWR		4.0	4.5		
GPS Low Noise Amplifier					I _{CC} =10mA
Frequency		1575		MHz	
Gain	17.0	19.0	21.0	dB	
Noise Figure		1.1	1.3	dB	
IIP3	3	5		dBm	
IP1dB	-7	-5		dBm	
Input VSWR		1.7	2.2		
Output VSWR		1.6	2.1		
PCS Low Noise Amplifier					I _{CC} =10mA
Frequency Range	1850	1920	1990	MHz	
Gain	16.0	18.0	20.0	dB	
Noise Figure		1.2	1.4	dB	
IIP3	4	6		dBm	
IP1dB	-7	-5		dBm	
Input VSWR		1.8	2.3		
Output VSWR		1.6	2.1		

Parameter	Specification			Unit	Condition
	Min.	Typ.	Max.		
W-CDMA Low Noise Amplifier					
Frequency Range	1920	2045	2170	MHz	$I_{CC}=10\text{mA}$
Gain	15.5	17.5	19.5	dB	
Noise Figure		1.2	1.4	dB	
IIP3	6	8		dBm	
IP1dB	-3	-1		dBm	
Input VSWR		1.8	2.3		
Output VSWR		1.6	2.1		
WLAN Low Noise Amplifier					
Frequency	2400	2450	2500	MHz	$I_{CC}=10\text{mA}$
Gain	13.0	15.0	17.0	dB	
Noise Figure		1.3	1.5	dB	
IIP3	7.5	9.5		dBm	
P1dB	-5.5	-3.5		dBm	
Input VSWR		1.7	2.2		
Output VSWR		1.1	1.6		
Cellular Driver					
Frequency	820	880	960	MHz	$I_{CC}=18\text{mA}$
Gain	20.0	22.0	24.0	dB	
Noise Figure		1.2	1.4	dB	
OIP3	19	21		dBm	
OP1dB	9	11		dBm	
Input VSWR		2.0	2.5		
Output VSWR		4.0	4.5		
PCS Driver					
Frequency Range	1850	1920	1990	MHz	$I_{CC}=18\text{mA}$
Gain	16.5	18.5	20.5	dB	
Noise Figure		1.3	1.5	dB	
OIP3	21.5	23.5		dBm	
OP1dB	10.5	12.5		dBm	
Input VSWR		1.8	2.3		
Output VSWR		1.6	2.1		
W-CDMA Driver					
Frequency Range	1920	2045	2170	MHz	$I_{CC}=18\text{mA}$
Gain	15.0	17.5	20.0	dB	
Noise Figure		1.3	1.5	dB	
OIP3	23.5	25.5		dBm	
OP1dB	14.5	16.5		dBm	
Input VSWR		1.8	2.3		
Output VSWR		1.6	2.1		
WLAN Driver					
Frequency	2400	2450	2500	MHz	$I_{CC}=18\text{mA}$
Gain	13.5	15.5	17.5	dB	
Noise Figure		1.4	1.6	dB	
OIP3	23	25		dBm	
OP1dB	10	12		dBm	
Input VSWR		1.7	2.2		
Output VSWR		1.1	1.6		

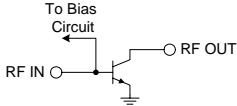
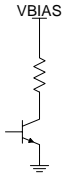
Pin	Function	Description	Interface Schematic
1	RF IN	RF input pin. This pin is DC coupled.	
2	GND1	Ground connection. For best performance, keep traces physically short and connect immediately to ground plane.	
3	BIAS	This pin is used to control the bias current. An external resistor can be used to set the bias current for any V_{BIAS} voltage. See table with evaluation board schematic.	
4	RF OUT	Amplifier output pin. This pin is an open-collector output. It must be biased to V_{CC} through a choke or matching inductor. This pin is typically matched to 50Ω with a shunt bias/matching inductor and series blocking/matching capacitor. Refer to application schematics.	
5	GND2	Ground connection. For best performance, keep traces physically short and connect immediately to ground plane.	

Evaluation Board Schematic

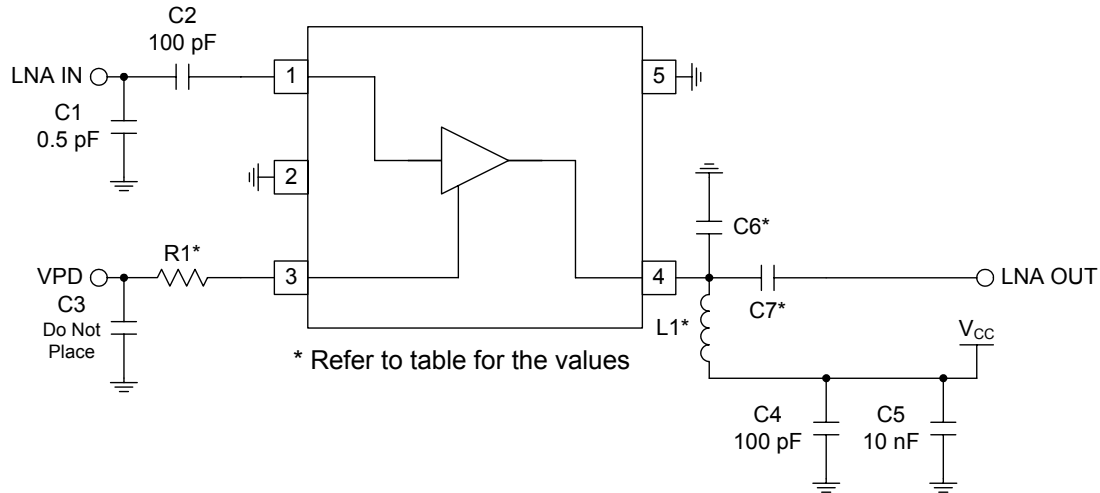

Component	Cellular 900 MHz	GPS 1575 MHz	PCS 1950 MHz	W-CDMA 2140 MHz	WLAN 2450 MHz
L1 (nH)	3.9	2.7	2.7	2.7	2.2
C6 (pF)	4.3	1.5	0.5	DNP	DNP
C7 (pF)	2.0	1.2	1.0	1.0	1.0

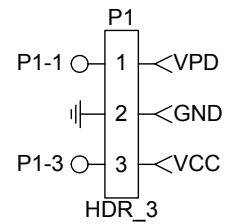

V _{PD}	I _{CC}				
	R1 = 300 Ω	R1 = 430 Ω	R1 = 560 Ω	R1 = 1 kΩ	R1 = 1.5 kΩ
2.7	12	9	7	5	4
3.0	16	12	9	6	5
3.3	20	15	11	7	5
3.6	25	19	14	8	6
4.0	31	24	18	10	7
4.5	Over Limit	31	23	13	8
5.0	Over Limit	Over Limit	29	16	10

Note: V_{CC} set to 3.3 V. I_{CC} only slightly dependent on V_{CC}.

This information pertains to the following charts.

Test condition unless otherwise specified: $V_{CC}=3.3V$, use evaluation board for corresponding frequencies.

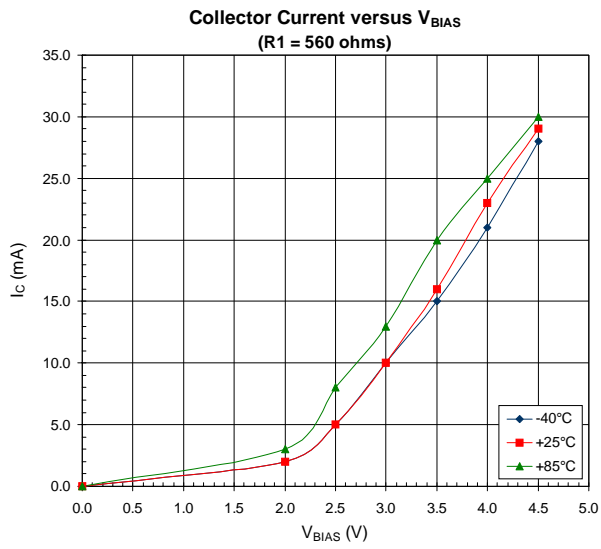

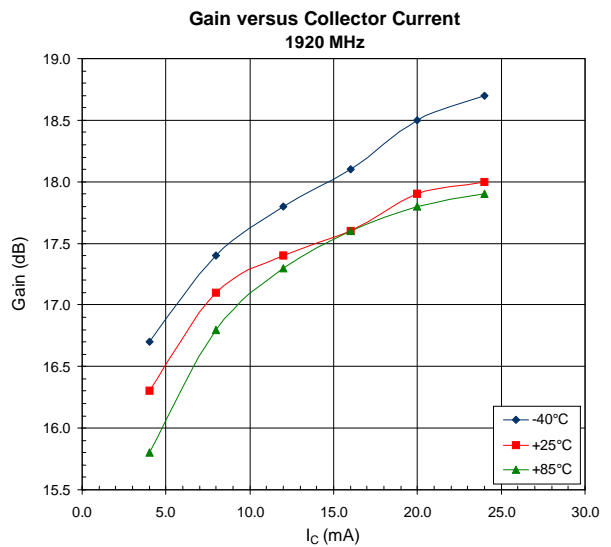
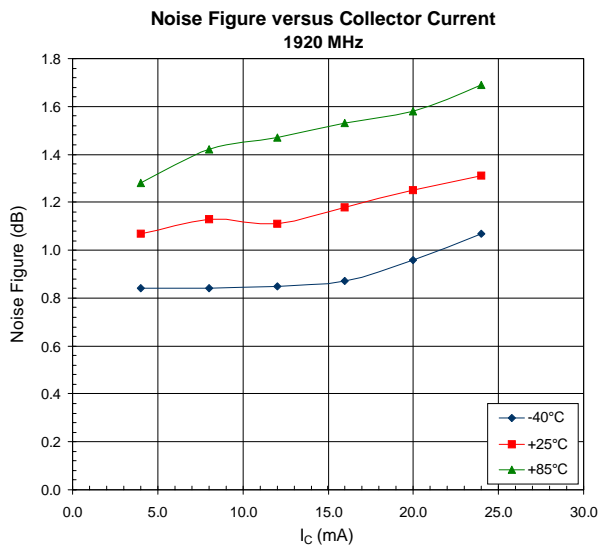
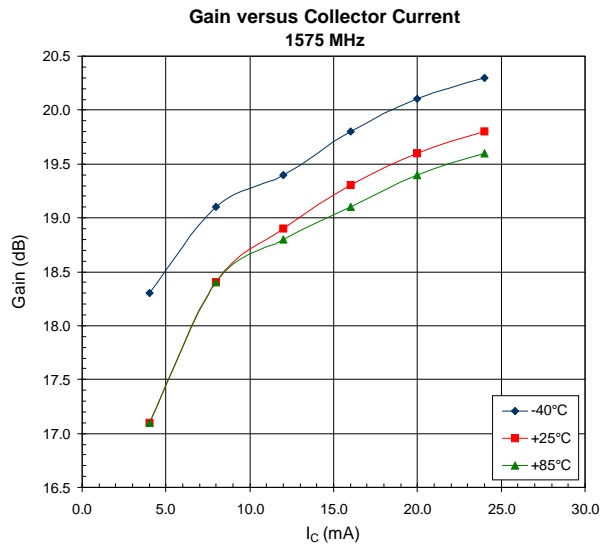
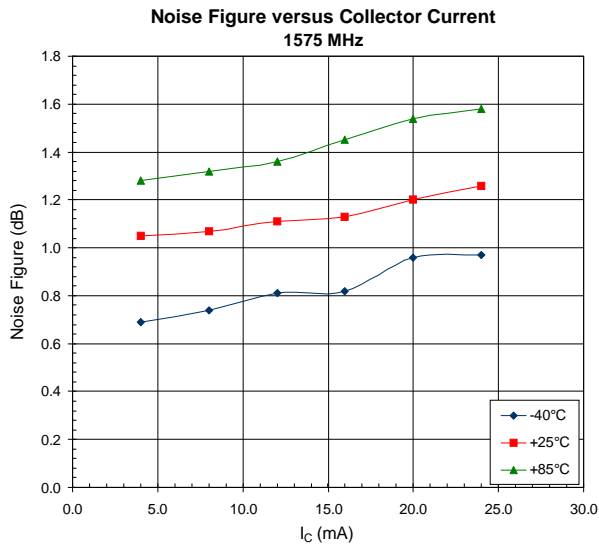
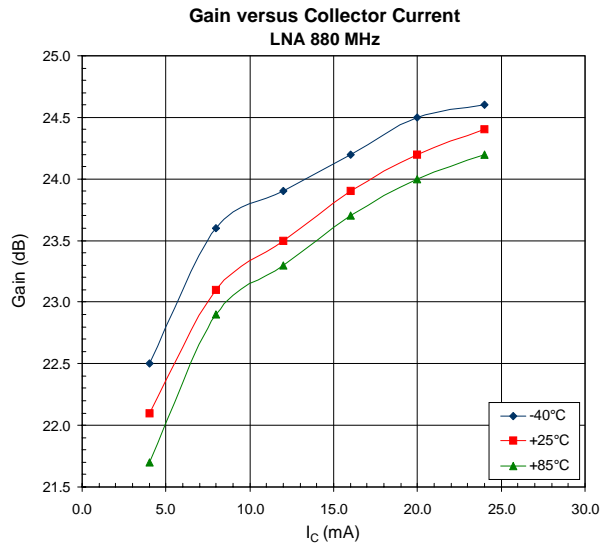
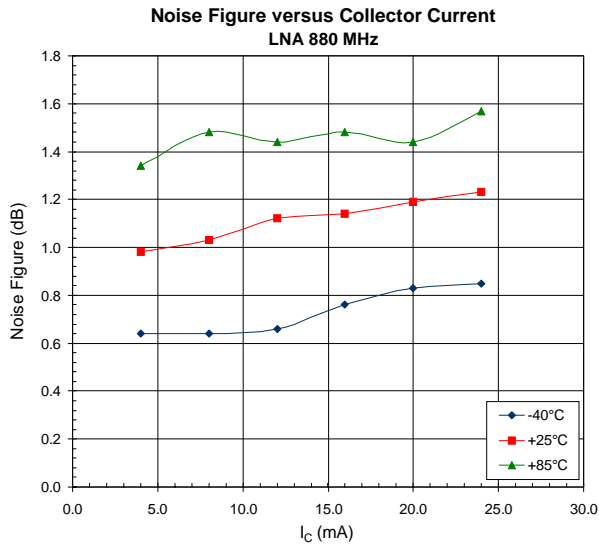

Noise Figure versus Collector Current
2025 MHz

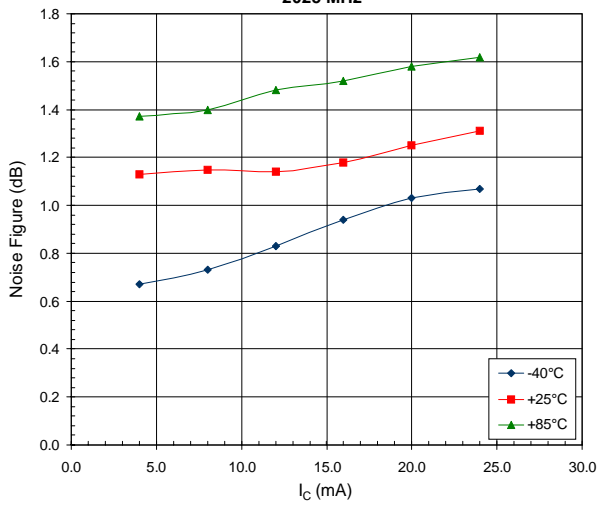

Gain versus Collector Current
2025 MHz

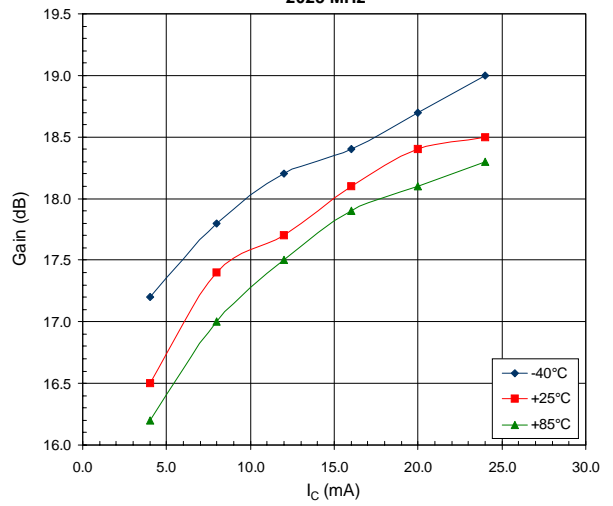

Noise Figure versus Collector Current
2450 MHz

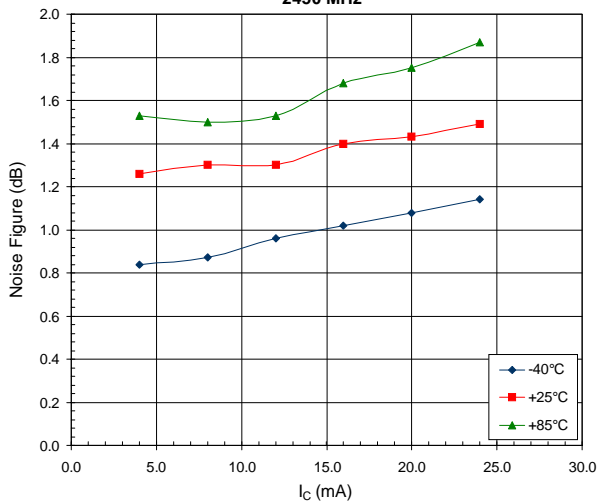

Gain versus Collector Current
2450 MHz

