

RMPA2451-58

2.4-2.5 GHz GaAs MMIC

Power Amplifier

PRODUCT INFORMATION

Description

Raytheon RF Components' RMPA2451-58 is a partially matched monolithic power amplifier in a surface mount package for use in wireless applications in the 2.4 to 2.5 GHz ISM frequency band. The amplifier may be biased for linear, class AB or class F for high efficiency applications. External matching components are required to optimize the RF performance. The MMIC chip design utilizes Raytheon RF Components' 0.25µm power Pseudomorphic High Electron Mobility (PHEMT) process.

Features

- ◆ 38% Power Added Efficiency
- ◆ 29 dBm Typical Output Power
- ◆ Small package outline: 0.28"x 0.28"x 0.07"
- ◆ Low Power Mode: 0 dBm



Absolute Ratings

Parameter	Symbol	Min	Max	Units
Positive Drain DC Voltage	Vd1,Vd2	0	+8	Volts
Negative Gate DC Voltage	Vg1,Vg2	-5	0	Volts
Simultaneous Drain to Gate Voltage	Vd-Vg		+10	Volts
RF Input Power (from 50 Ω source)	Pin		+10	dBm
Drain Current, First Stage	Id1		75	mA
Drain Current, Second Stage	Id2		525	mA
Gate Current	Ig		5	mA
Channel Temperature	Tc		175	°C
Operating Case Temperature	Tcase	-40	85	°C
Storage Temperature Range	Tstg	-40	125	°C
Thermal Resistance (Channel to Case)	Rjc		33	°C/Watt

Electrical Characteristics¹

Parameter	Min	Typ	Max	Unit
Frequency Range	2400		2500	MHz
Gain ¹	28.5	33		dB
Output Power, P1dB ¹	27	29		dBm
Power Added Efficiency		38		%

Parameter	Min	Typ	Max	Unit
3rd order Intermod. Product ²		-35	-27	dBc
Drain Current (Id1 + Id2)		430		mA
Gate Current (Ig1 + Ig2)		5		mA
Input Return Loss (50W)		2:1		dB
Low Power Mode, Pout ³	0			dBm

Notes:

1. Production Testing includes Gain, Output Power at 1-dB gain compression (P1dB) and Input Return Loss at Vd1 = Vd2 = +5.0V; Vg1,Vg2 = -0.5V (nominal), adjust Vg1 and Vg2 to get Idq1 = 60 mA, Idq2 = 340 mA and at F = 2.45 GHz, at 25°C.
 2. Two tone 3rd order Output Intermodulation products (IM3) are measured with total output power level of 25dBm (tone spacing is 1MHz).
 3. Vg1, Vg2 tied together. Vd = 5V until Idq total = 45 mA, Pin = -10 dBm.
- Other Parameters are guaranteed by Design Validation Testing (DVT).

RMPA2451-58

2.4-2.5 GHz GaAs MMIC

Power Amplifier

Application Information

CAUTION: THIS IS AN ESD SENSITIVE DEVICE.

The following describes the procedure for evaluating the RMPA2451-58, a partially-matched PHEMT monolithic power amplifier which has been designed for wireless applications in the 2.4 - 2.5 GHz ISM band, in a surface mount package. The package outline, along with the pin designations, is provided as Figure 1. The functional block diagram of the packaged product is provided as Figure 2.

It should be noted that the RMPA2451-58 requires the use of external passive components to form the DC bias and RF output matching circuits. The schematic for a recommended DC bias / RF matching circuit is shown in Figure 3, along with a list of the appropriate components. Figure 4 illustrates the layout of an evaluation board based on this schematic (RMPA2451-58-TB).

Figures 5 and 6 illustrate typical device performance. This data for various operating parameters was obtained across the design bandwidth over a range of temperatures.

Figure 5 shows the variation in Gain and P1dB with temperature and operating frequency.

Figure 6 shows the 3rd-order intermodulation product measured at different total output power levels.

Figure 1
Package Information

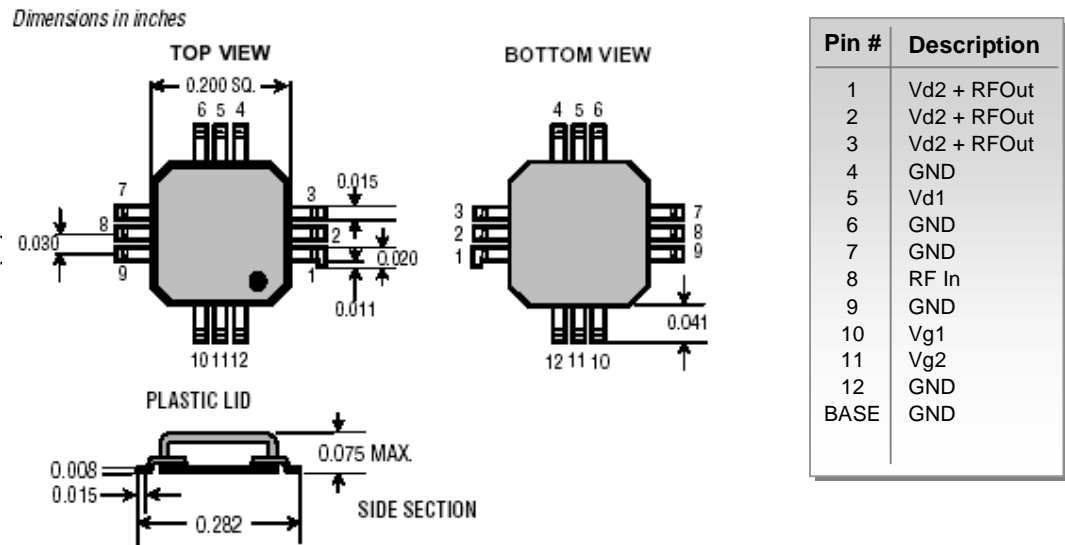
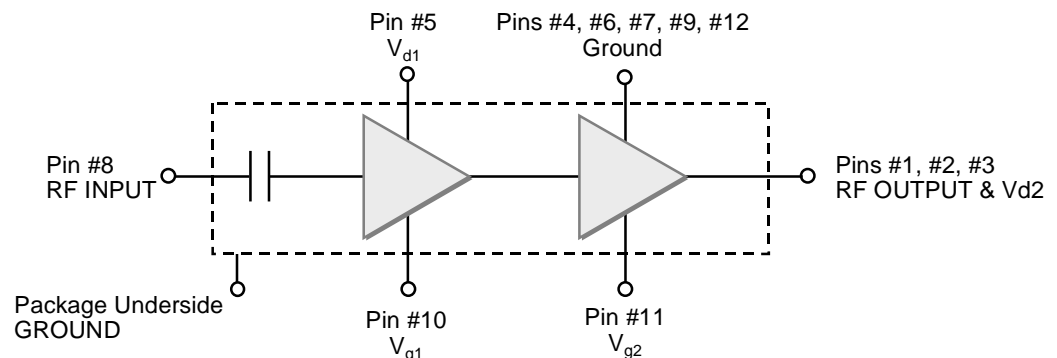

Figure 2
Functional Block Diagram



RMPA2451-58

2.4-2.5 GHz GaAs MMIC

Power Amplifier

Test Procedure
for the
evaluation board
(RMPA2451-58-TB)

- It is important that the following points be noted prior to testing; Pin designations are as shown in Figure 2 and 4.
- ◆ V_{gg1} and V_{gg2} are the negative Gate bias voltages applied at the pins of the evaluation test board.
 - ◆ V_{dd1} and V_{dd2} are the positive Drain bias voltages applied at the pins of the evaluation test board.
 - ◆ V_{g1} and V_{g2} are the negative Gate bias voltages applied at the pins of the package.
 - ◆ V_{d1} and V_{d2} are the positive Drain bias voltages applied at the pins of the package.

CAUTION: LOSS OF GATE VOLTAGES (VG1, VG2) WHILE DRAIN VOLTAGES (VD1, VD2) ARE PRESENT MAY DAMAGE THE AMPLIFIER.

The following sequence of procedures must be followed to properly test the amplifier:

- Step 1:** Turn the RF power OFF.
- Step 2:** Use the GND terminals of the evaluation board for the ground of the DC supplies.
- Step 3:** Apply a nominal voltage of approximately -3.0V to both V_{gg1} and V_{gg2} terminals.
- Step 4:** Apply a nominal voltage of +5.0V to the V_{dd} terminals. Adjust V_{gg2} to provide a second stage quiescent Drain current, I_{dd2} , of 340 mA.. Adjust V_{gg1} to give a first stage quiescent Drain current, I_{d1} of 60mA..
- Step 5:** Apply an RF signal within the ISM frequency range (2.4 - 2.5 GHz) at an initial input power level of -10 dBm.
- Step 6:** To perform intermodulation product measurements, a second RF signal generator

with a frequency difference of 1 MHz is required, along with an appropriate power combiner. The test configuration should allow this additional generator to provide the same input power level as the first generator into the device. Intermodulation readings may then be made at the required total output power levels.

- Step 7:** To operate at lower quiescent Drain currents, increase the magnitudes of V_{gg1} and V_{gg2} as required, alternatively to operate at higher quiescent Drain currents, the magnitudes of V_{gg1} and V_{gg2} should be decreased accordingly.
- Step 8:** When turning the amplifier OFF, the power-up sequence should be reversed.

Figure 3

Schematic of a recommended DC bias/ RF matching circuit

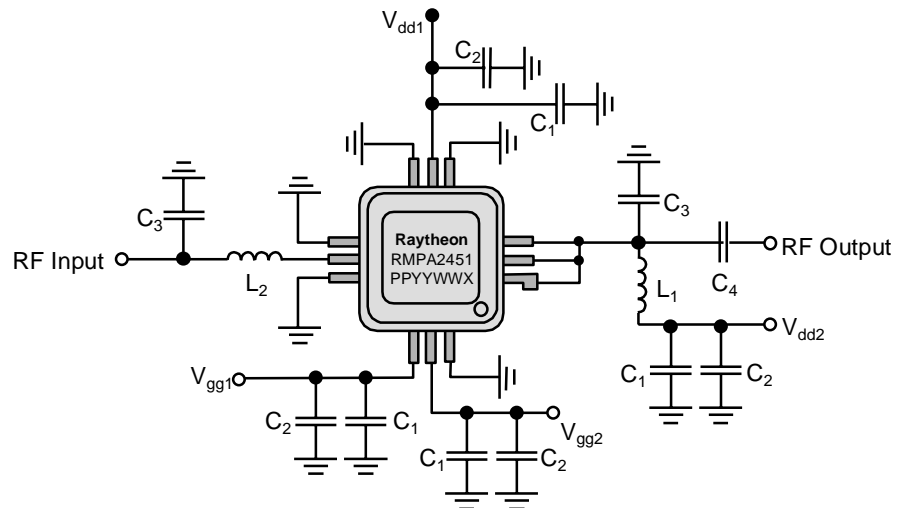

RMPA2451-58

2.4-2.5 GHz GaAs MMIC

Power Amplifier

Figure 4
Layout of
Evaluation
Board
(RMPA2451-58-
TB)

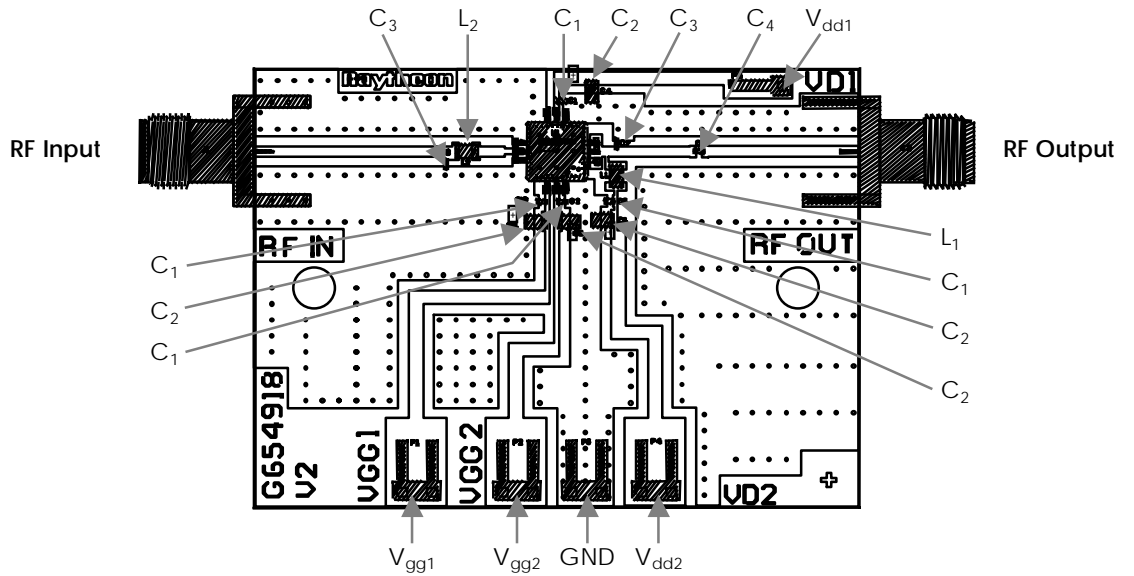

Parts List
for Test
Evaluation
Board

Part	Value	Quantity	Supplier	Part No.
C1	1000 pF	4	MURATA	GRM36X7R102K050
C2	2.2 μ f	4	SPRAGUE	595D225X0016T2T
C3	1.0 pF	2	MURATA	GRM36COG1R0B050
C4	2.0 pF	1	MURATA	GRM36COG2R0B050
L1	10.0 nH	1	COILCRAFT	0805HT10NTKBC
L2	1.8 nH	1	COILCRAFT	0805HT1N8TKBC

RMPA2451-58

2.4-2.5 GHz GaAs MMIC

Power Amplifier

Figure 5
Typical Gain and P1dB performance across bandwidth over temperature

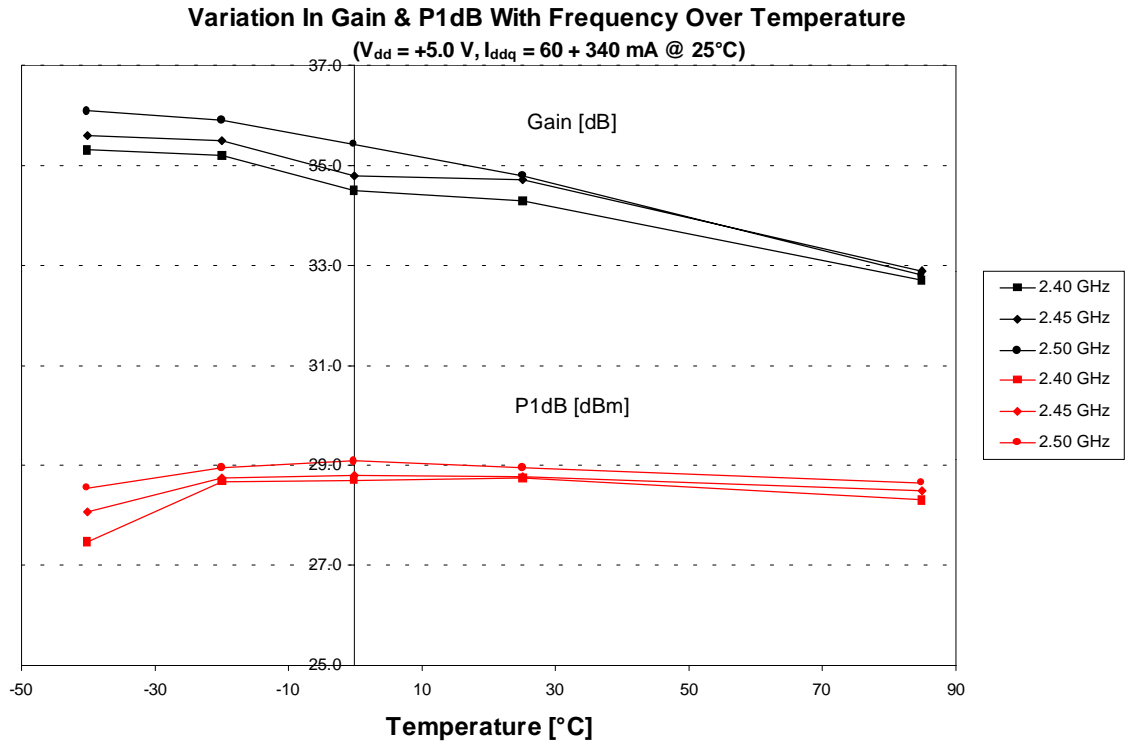

NB: Gain measured at $P_{in} = -10\text{ dBm}$

Figure 6
Typical third-order intermodulation product variation over temperature

