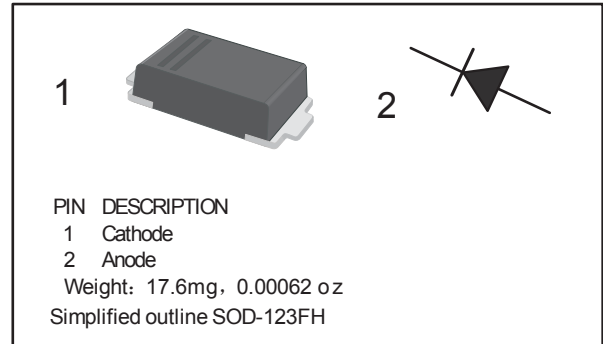

Fast Recovery diodes

RS1AFH ~ RS1MFH

■ Features

- Low leakage current
- Excellent stability
- Guaranteed avalanche energy absorption capability
- Glass passivated
- High maximum operating temperature

■ Absolute Maximum Ratings $T_a = 25^\circ\text{C}$

Parameter	Symbol	RS1A FH	RS1B FH	RS1D FH	RS1G FH	RS1J FH	RS1K FH	RS1M FH	Unit
Repetitive Peak Reverse Voltage	V_{RRM}	50	100	200	400	600	800	1000	V
Surge Peak Reverse Voltage	V_{RSM}	35	70	140	280	420	560	700	
Maximum DC Blocking Voltage	V_R	50	100	200	400	600	800	1000	
Averaged Forward Current $T_T=110^\circ\text{C}$	I_{FAV}	1							A
Peak Forward Surge Current $T_j=25^\circ\text{C}, V_R=V_{RRMMax}$	I_{FSM}	25							
Thermal Resistance From Junction to Ambient (Note.1) (Note.2)	R_{thj-a}	100							K/W
		150							
Thermal Resistance Junction to Tie-Point	R_{thj-tp}	27							
Junction Temperature	T_j	150							$^\circ\text{C}$
Storage Temperature	T_{stg}	-50 to 150							

Note.1 Device mounted on Al_2O_3 printed-circuit board, 0.7 mm thick; thickness of copper ≥ 35 mm.

Note.2 Device mounted on epoxy-glass printed-circuit board, 1.5 mm thick; thickness of copper ≥ 40 mm. For more information please refer to the 'General Part of associated Handbook'.

■ Electrical Characteristics $T_a = 25^\circ\text{C}$

Parameter	Symbol	Test Conditions	Min	Typ	Max	Unit
Forward Voltage	V_F	$I_F=1\text{A}$			1.3	V
Maximum DC Reverse Current	I_R	$V_R=V_{RRMMax}$			5	μA
		$V_R=V_{RRMMax}, T_J=125^\circ\text{C}$			50	
Reverse Recovery Time	t_{rr}	$I_F = 0.5\text{ A}, I_R = 1\text{ A}, \text{RS1A to RS1J}$			250	ns
		$I_F = 0.5\text{ A}, I_R=0.25\text{ A}, \text{RS1K and RS1M}$			300	
Diode Capacitance	C_d	$V_R=4\text{V}, f=1\text{MHz}$		7		pF

Fast Recovery diodes RS1AFH ~ RS1MFH

■ Typical Characteristics

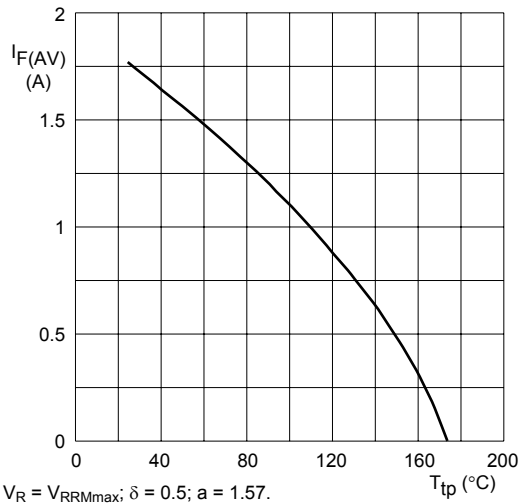

Fig.2 Maximum permissible average forward current as a function of tie-point temperature (including losses due to reverse leakage).

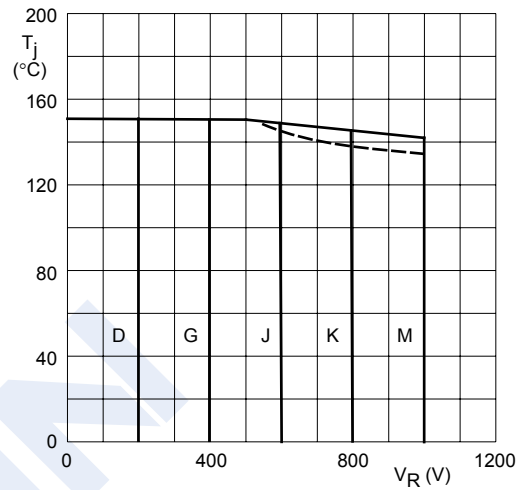
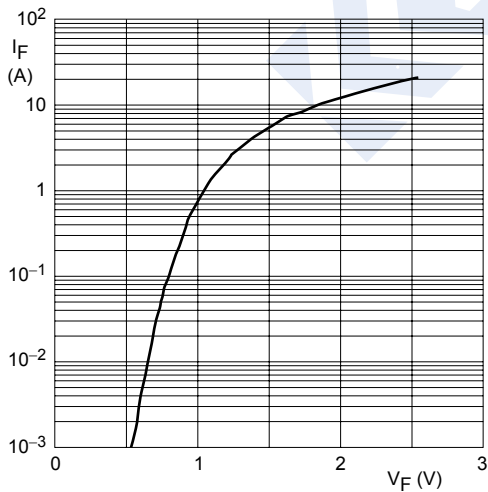

Fig.3 Maximum permissible junction temperature as a function of reverse voltage.



$T_j = 25$ °C.

Fig.4 Forward current as a function of forward voltage; typical values.

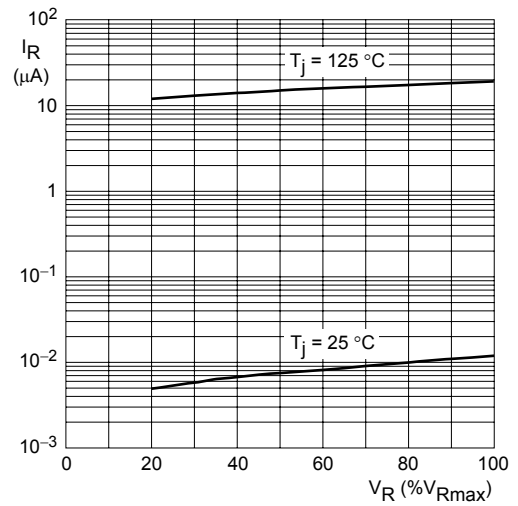
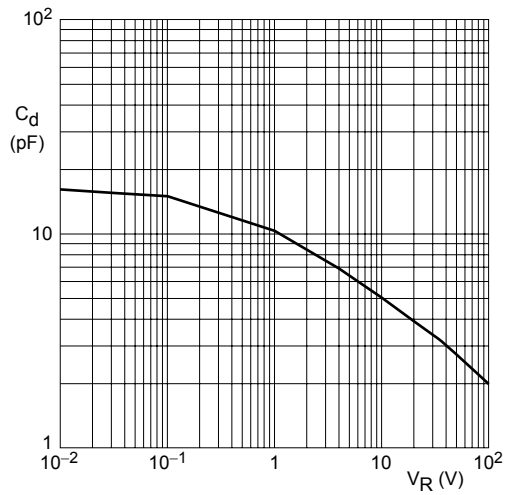

Fig.5 Reverse current as a function of reverse voltage; typical values.

Fast Recovery diodes

RS1AFH ~ RS1MFH

■ Typical Characteristics



$f = 1 \text{ MHz}$; $T_j = 25 \text{ }^\circ\text{C}$.

Fig.6 Diode capacitance as a function of reverse voltage; typical values.

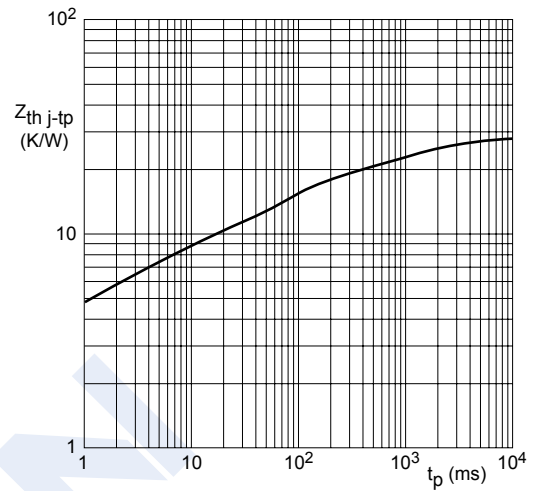

Fig.7 Transient thermal impedance as a function of pulse width.

Fast Recovery diodes RS1AFH ~ RS1MFH

■ Typical Application

Plastic surface mounted package; 2 leads

