

## DESCRIPTION

RS2336 is a highly performance offline 700V high voltage start up Quasi-Resonant (QR) controller for low power fly-back converter applications.

RS2336 features multiple modes for controlling power conversion that are designed to achieve maximum efficient across a wide range of loads. At normal load condition, it operates in QR mode with minimum drain voltage switching. It operates in PFM mode for high power conversion efficiency at light load condition. When the loading is very small RS2336 operates in Hiccup Mode to minimize the switching loss. As a result, lower standby power consumption and higher conversion efficiency is achieved.

RS2336 offers power on programmable soft-start control and ensures safe operation with complete protections against all the fault conditions. Built-in protections circuitry includes Cycle-by-Cycle current limiting, peak current protection, OTP · OLP, Output OVP, VCC OVP, VCC clamp and UVLO, etc.

## APPLICATIONS

Offline AC/DC Fly-back Converter for

- Power Adapter and Open-frame SMPS
- NB/DVD/Portable DVD Power Supplies
- LCD Monitor/TV/PC/Set-Top Box Power Supplies
- LED power

## FEATURES

- Multi-Mode Operation
  - Quasi-Resonant (QR) Operation at Normal Loading
  - Pulse Frequency Modulation (PFM) Operation at Light Loading
  - Hiccup Mode (HM) Operation at No Loading
- 700V high voltage start up
- Low standby power (<0.15W)
- 40KHz Minimum Frequency Limit at QR Mode
- 130KHz Maximum Frequency Limit
- Maximum On Time Limit
- Maximum and Minimum OFF time Limit
- Built-in Leading Edge Blanking
- Programmable Soft-start
- External Latch Triggering
  - Rich Protections For System Reliability including
  - VCC Under Voltage Lockout with Hysteresis (UVLO)
  - Cycle-by-Cycle Current Limiting and Peak Current Protection (OCP)
  - Programmable Output Over Voltage Protection (OVP)
  - Over Loading Protection (OLP)
  - Over Temperature Protection (OTP)
  - VCC Over Voltage Protection
  - VCC Clamp
- RoHS Compliant and 100% Lead (Pb)-Free

## BLOCK DIAGRAM

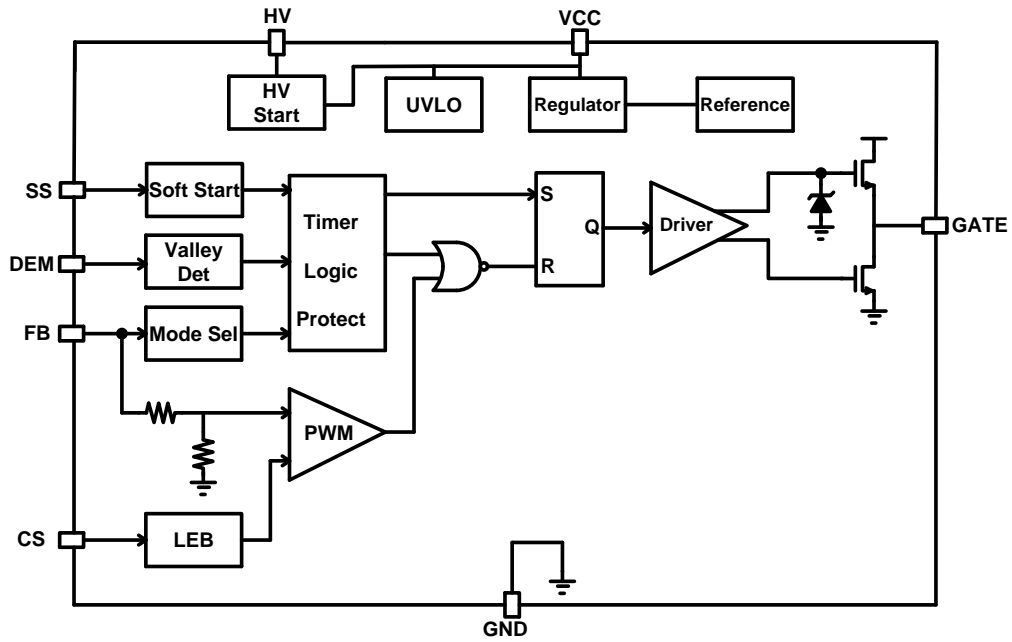

## APPLICATION CIRCUITS

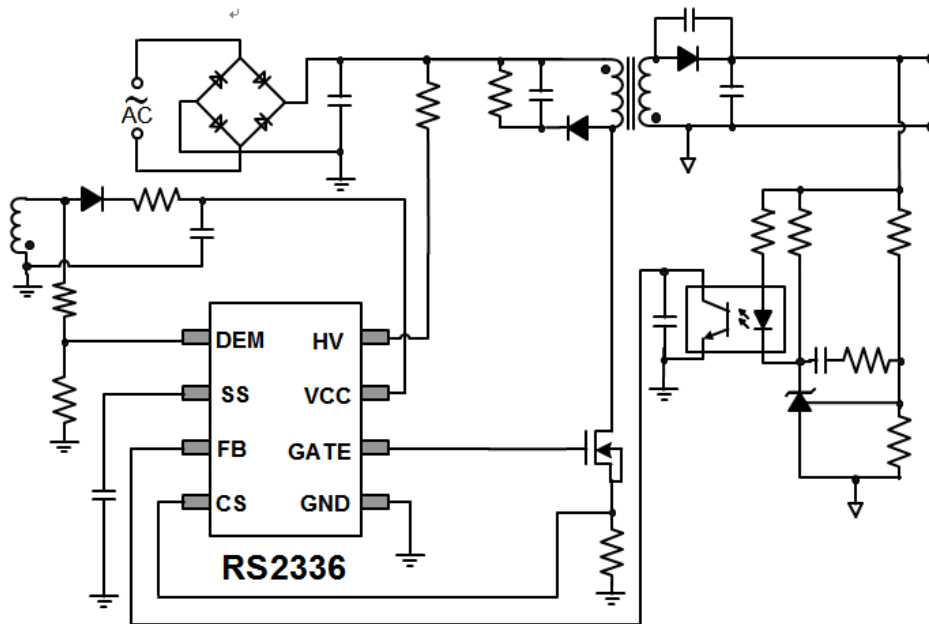

## ORDERING INFORMATION

Device	Device Code
RS2336 Y Z	Y is package designator : S : SOP-8 D : DIP-8 Z is Lead Free designator : P: Commercial Standard, Lead (Pb) Free and Phosphorous (P) Free Package

## PIN ASSIGNMENTS

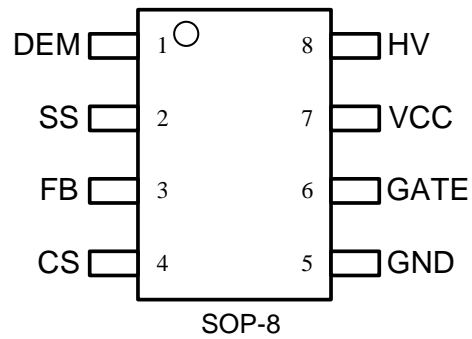
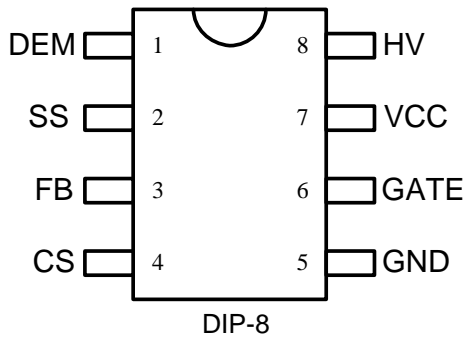

## PIN DESCRIPTION

Pin Name	Description	Pin No.
DEM	Input from auxiliary winding for demagnetization timing. The auxiliary fly-back signal ensures discontinuous operation.	1
SS	Soft-start programming pin. Connect a capacitor to ground.	2
FB	Feedback input pin. PWM duty cycle is determined by the voltage level. The voltage level at this pin also controls the operation mode.	3
CS	Current sense input.	4
GND	Ground.	5
GATE	Gate driver output. Drive the power MOSFET.	6
VCC	Chip power supply pin.	7
HV	Input for high voltage start up.	8

## **IMPORTANT NOTICE**

Princeton Technology Corporation (PTC) reserves the right to make corrections, modifications, enhancements, improvements, and other changes to its products and to discontinue any product without notice at any time. PTC cannot assume responsibility for use of any circuitry other than circuitry entirely embodied in a PTC product. No circuit patent licenses are implied.

Princeton Technology Corp.  
2F, 233-1, Baociao Road,  
Sindian Dist., New Taipei City 23145, Taiwan  
Tel: 886-2-66296288  
Fax: 886-2-29174598  
<http://www.princeton.com.tw>