

RS2501 thru RS2507

SINGLE-PHASE SILICON BRIDGE RECTIFIER

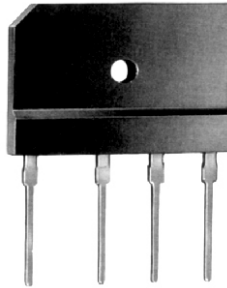

**CHENG-YI
ELECTRONIC**



FEATURES

- Low leakage
- Low forward voltage
- Mounting position: Any
- Surge overload rating: 300 amperes peak
- Silver-plated copper leads

VOLTAGE RANGE -50 to 1000 Volts
CURRENT 25 Amperes

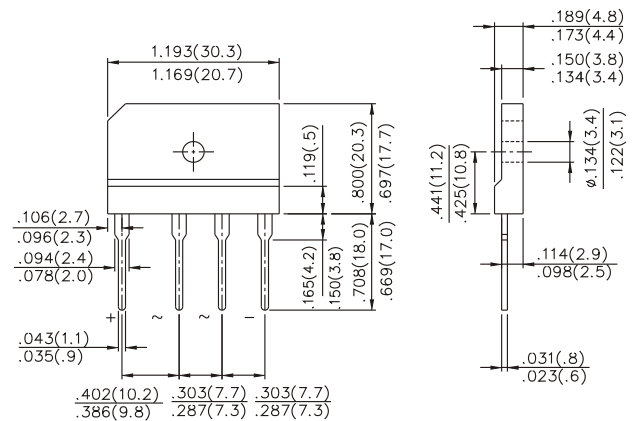

MAXIMUM RATINGS AND ELECTRICAL CHARACTERISTICS

Rating at 25°C ambient temperature unless otherwise specified.
Single phase, half wave, 60Hz, resistive or inductive load.
For capacitive load, derate current by 20%.

MAXIMUM RATINGS (At T_A=25°C unless otherwise noted)

Ratings	Symbol	RS2501	RS2502	RS2503	RS2504	RS2505	RS2506	RS2507	UNITS
Maximum Recurrent Peak Reverse Voltage	V _{RRM}	50	100	200	400	600	800	1000	Volts
Maximum RMS Bridge Input Voltage	V _{RMS}	35	75	140	280	420	560	700	Volts
Maximum DC Blocking Voltage	V _{DC}	50	100	200	400	600	800	1000	Volts
Maximum Average Forward Output Current at T _c =50°C	I _o	25							Amps
Peak Forward Surge Current, 8.3 ms single half sine-wave superimposed on rated load	I _{FSM}	300							Amps
Operating and Storage Temperature Range	T _J T _{STG}	-55 to +150							°C
Maximum Forward Voltage Drop per element at 12.0A DC	V _F	1.0							Volts
Maximum Reverse Current at Rated DC Blocking Voltage per element	@T _A =25°C	10							μ Amps
	@T _c =100°C	0.2							mAmps

RS2501 thru RS2507

SINGLE-PHASE SILICON BRIDGE



**CHENG-YI
ELECTRONIC**

RATING AND CHARACTERISTICS CURVES RS2501 THRU RS2507

Fig. 1 - MAXIMUM FORWARD SURGE CURRENT

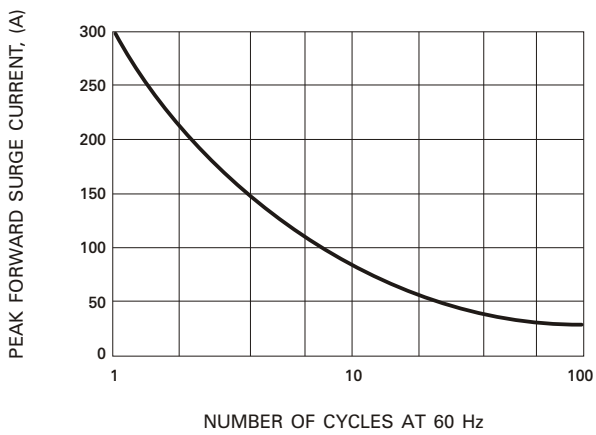

Fig. 2 - DERATING CURVE FOR
OUTPUT RECTIFIED CURRENT

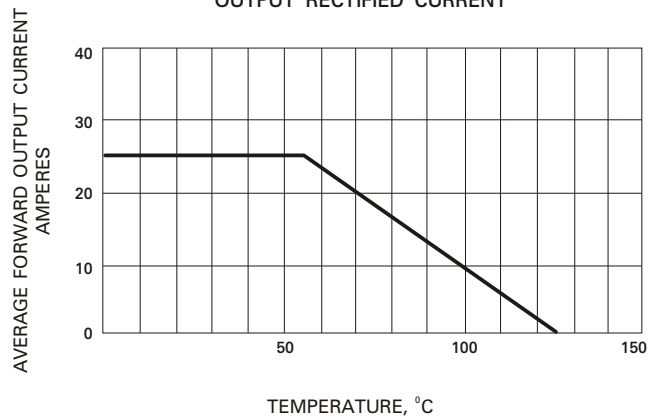

Fig. 3 - TYPICAL FORWARD
CHARACTERISTICS

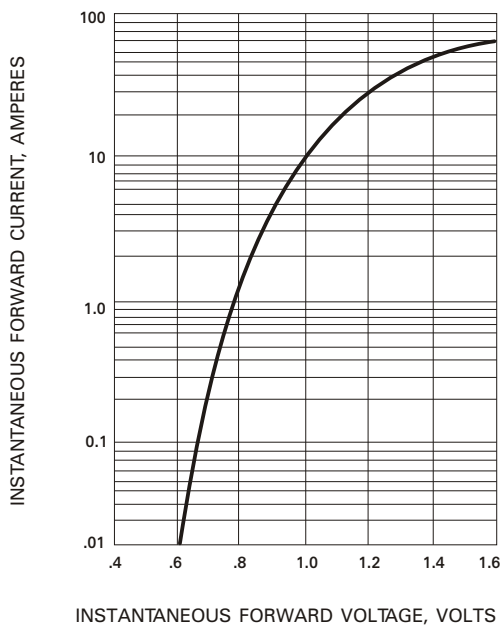

Fig. 4 - TYPICAL REVERSE
CHARACTERISTICS

