

600mA, Ultra-Fast Transient Response Linear Regulator

General Description

The RT9166B is a CMOS linear regulator optimized for ultra-fast transient response. The device is capable of supplying up to 600mA of output current and is optimized for CD/DVD-ROM, CD/RW or wireless communication applications. The RT9166B regulator is stable with output capacitor as low as 3.3 μ F. The other features include high output accuracy, current limiting protection, and high ripple rejection ratio. The RT9166B regulator is available in a 3-lead SOT-89 package.

Ordering Information

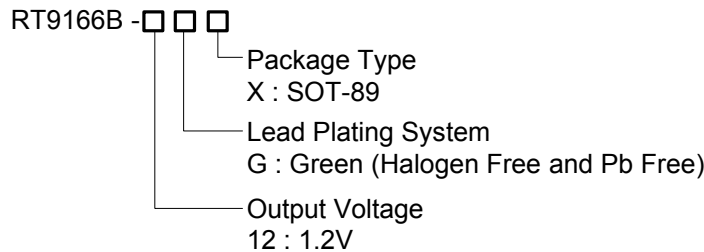

Note :

Richtek products are :

- ▶ RoHS compliant and compatible with the current requirements of IPC/JEDEC J-STD-020.
- ▶ Suitable for use in SnPb or Pb-free soldering processes.

Marking Information

For marking information, contact our sales representative directly or through a Richtek distributor located in your area.

Features

- Low Quiescent Current (Typically 220 μ A)
- Guaranteed 600mA Output Current
- Wide Operating Voltage Ranges : 2.8V to 5.5V
- Ultra-Fast Transient Response
- Tight Load and Line Regulation
- Current Limiting Protection
- Thermal Shutdown Protection
- Only Low-ESR Ceramic Capacitor Required for Stability
- Custom Voltage Available
- RoHS Compliant and Halogen Free

Applications

- CD/DVD-ROM, CD/RW
- Wireless LAN Card/Keyboard/Mouse
- Battery-Powered Equipment
- XDSL Router
- PCMCIA Card

Pin Configurations

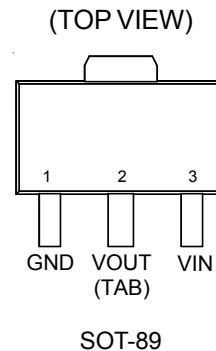

Typical Application Circuit

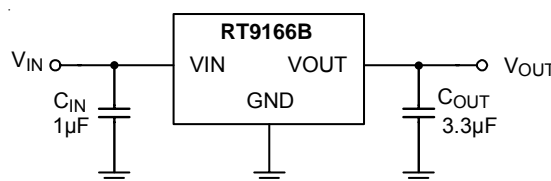

Functional Pin Description

Pin No.	Pin Name	Pin Function
1	GND	Common Ground.
2	VOUT	Regulator Output.
3	VIN	Supply Input.

Function Block Diagram

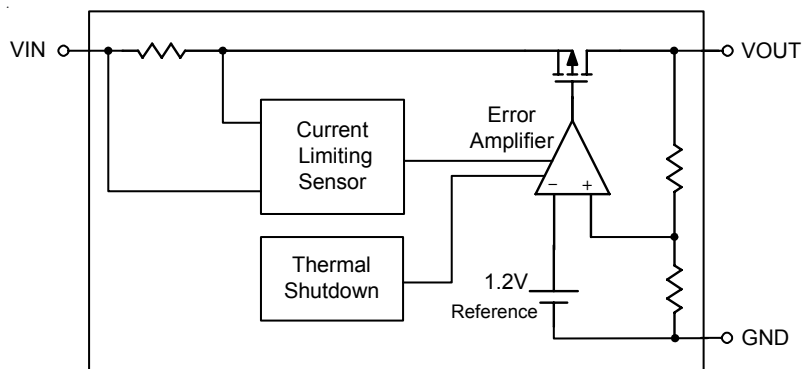

Absolute Maximum Ratings (Note 1)

- Supply Input Voltage ----- 6.5V
- Power Dissipation, P_D @ $T_A = 25^\circ\text{C}$
 SOT-89 ----- 0.847W
- Package Thermal Resistance (Note 2)
 SOT-89, θ_{JA} ----- 118°C/W
 SOT-89, θ_{JC} ----- 58°C/W
- Junction Temperature ----- 150°C
- Lead Temperature (Soldering, 10 sec.) ----- 260°C
- Storage Temperature Range ----- -65°C to 150°C
- ESD Susceptibility (Note 3)
 HBM (Human Body Mode) ----- 2kV
 MM (Machine Mode) ----- 200V

Recommended Operating Conditions (Note 4)

- Supply Input Voltage ----- 2.8V to 5.5V
- Junction Temperature Range ----- -40°C to 125°C
- Ambient Temperature Range ----- -40°C to 85°C

Electrical Characteristics

($V_{IN} = 2.8\text{V}$ whichever is greater; $C_{IN} = 1\mu\text{F}$, $C_{OUT} = 3.3\mu\text{F}$, $T_A = 25^\circ\text{C}$, unless otherwise specified)

Parameter	Symbol	Test Conditions	Min	Typ	Max	Unit
Output Voltage Accuracy	ΔV_{OUT}	$I_{OUT} = 1\text{mA}$	-1	--	3	%
Current Limit	I_{LIM}	$R_{LOAD} = 1\Omega$	600	--	--	mA
Quiescent Current (Note 5)	I_Q	$I_{OUT} = 0\text{mA}$	--	220	300	μA
Line Regulation	ΔV_{LINE}	$V_{IN} = 2.8\text{V to } 5.5\text{V}$, $I_{OUT} = 1\text{mA}$	--	0.2	--	%V
Load Regulation (Note 6)	ΔV_{LOAD}	$1\text{mA} < I_{OUT} < 600\text{mA}$	--	30	55	mV
Power Supply Rejection Rate	PSRR	$f = 1\text{kHz}$, $C_{OUT} = 1\mu\text{F}$	--	-55	--	dB
Thermal Shutdown Temperature	T_{SD}		--	170	--	°C
Thermal Shutdown Hysteresis	ΔT_{SD}	$I_{SW} = 0.2\text{A}$	--	40	--	°C

- Note 1.** Stresses listed as the above “Absolute Maximum Ratings” may cause permanent damage to the device. These are for stress ratings. Functional operation of the device at these or any other conditions beyond those indicated in the operational sections of the specifications is not implied. Exposure to absolute maximum rating conditions for extended periods may remain possibility to affect device reliability.
- Note 2.** θ_{JA} is measured in the natural convection at $T_A = 25^\circ\text{C}$ on a high effective four-layer thermal conductivity test board of JEDEC 51-7 thermal measurement standard. The measurement case position of θ_{JC} is on the expose pad of the package.
- Note 3.** Devices are ESD sensitive. Handling precaution is recommended.
- Note 4.** The device is not guaranteed to function outside its operating conditions.
- Note 5.** Quiescent, or ground current, is the difference between input and output currents. It is defined by $I_Q = I_{IN} - I_{OUT}$ under no load condition ($I_{OUT} = 0\text{mA}$). The total current drawn from the supply is the sum of the load current plus the ground pin current.
- Note 6.** Regulation is measured at constant junction temperature by using a 20ms current pulse. Devices are tested for load regulation in the load range from 1mA to 600mA respectively.

Typical Operating Characteristics

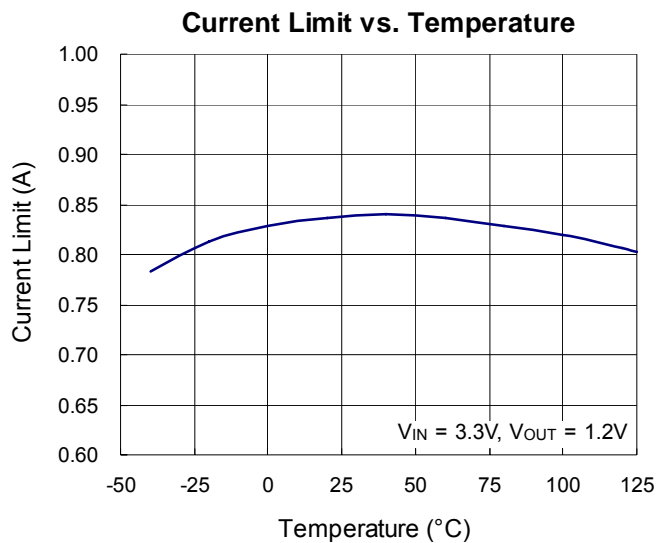
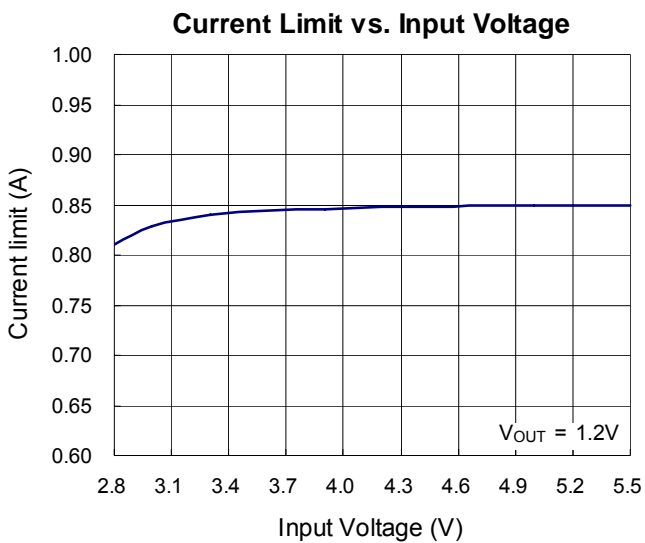
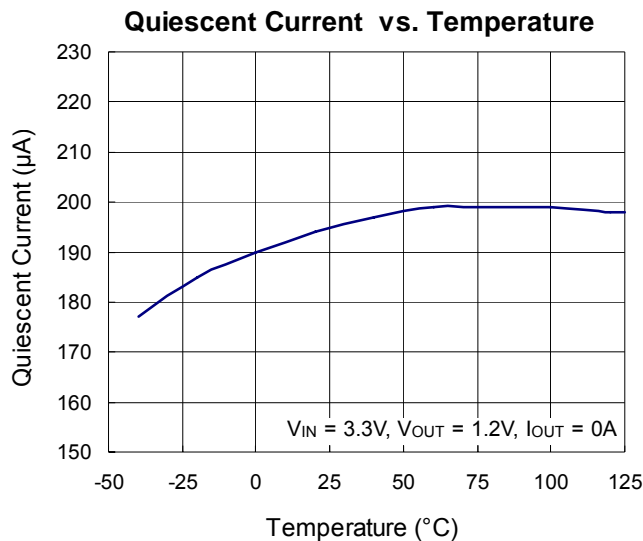
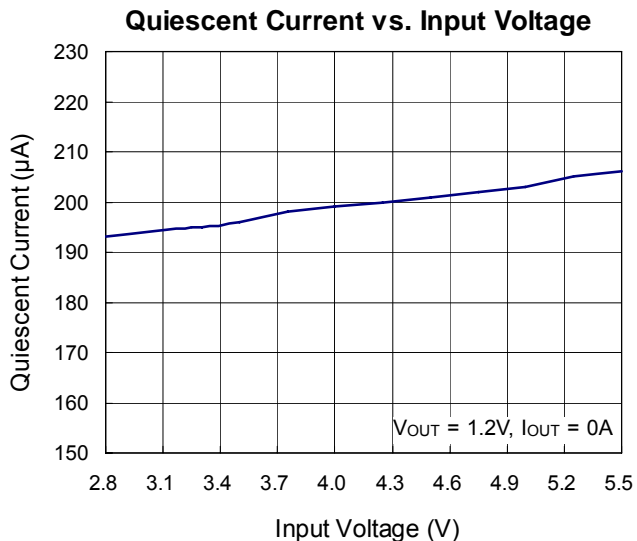
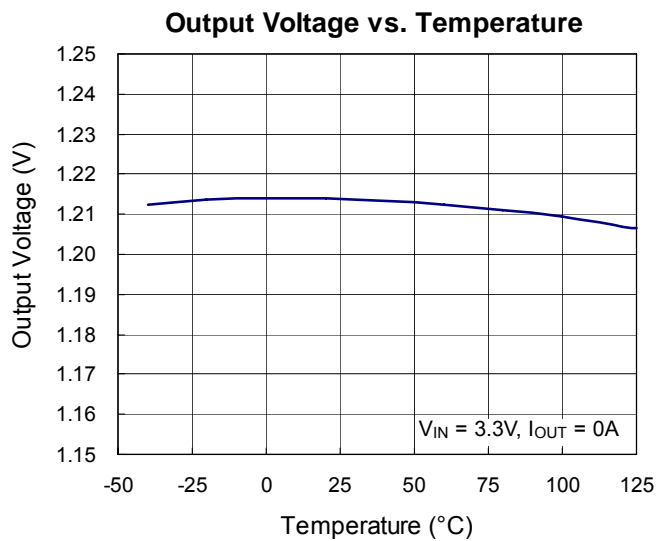
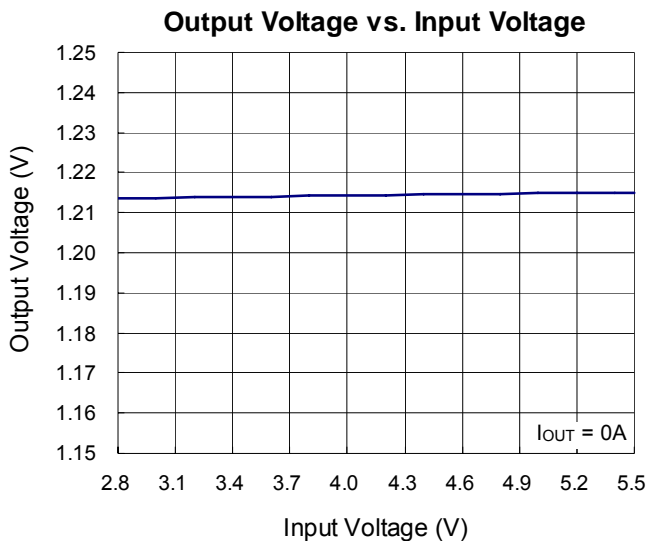

Power On from VIN

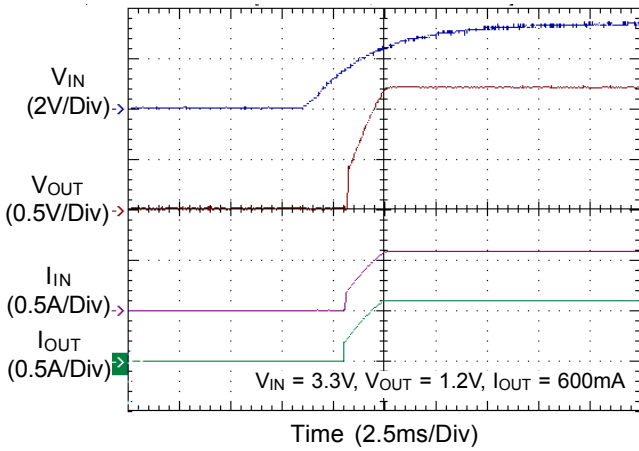

Power Off from VIN

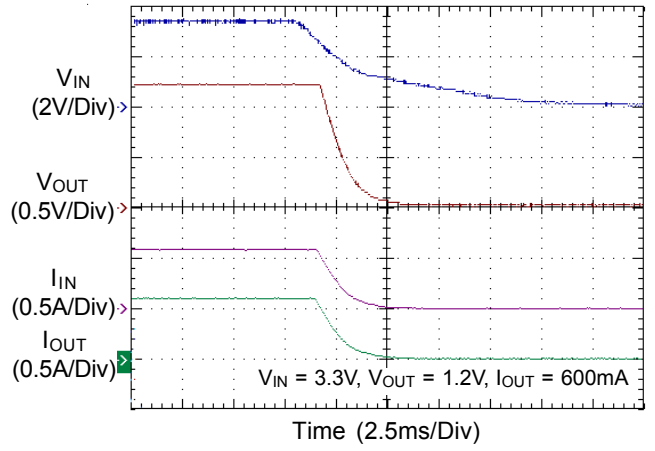

Load Transient Response

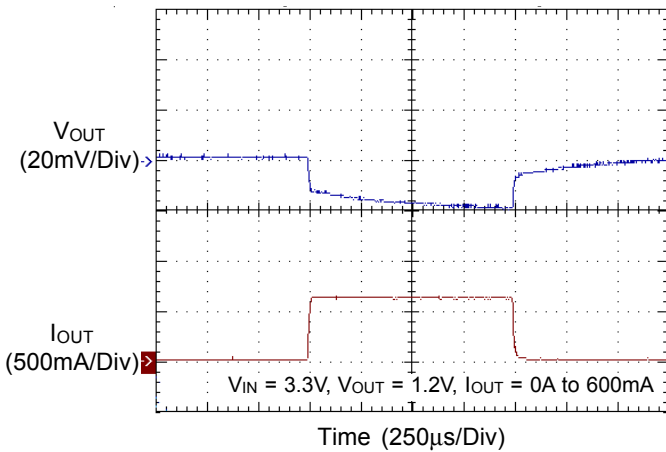

Load Transient Response

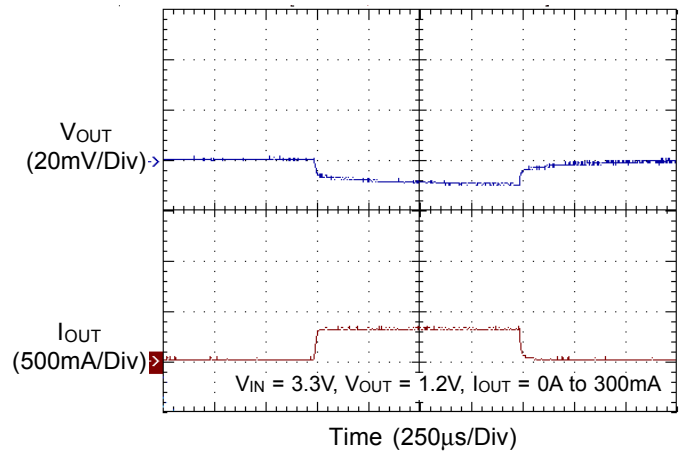

Line Transient Response

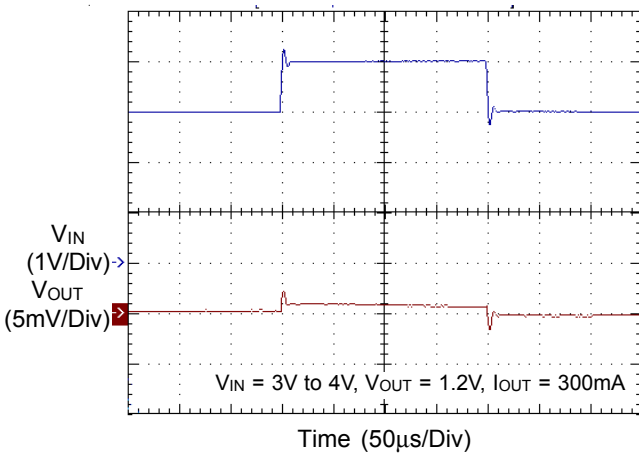

PSRR

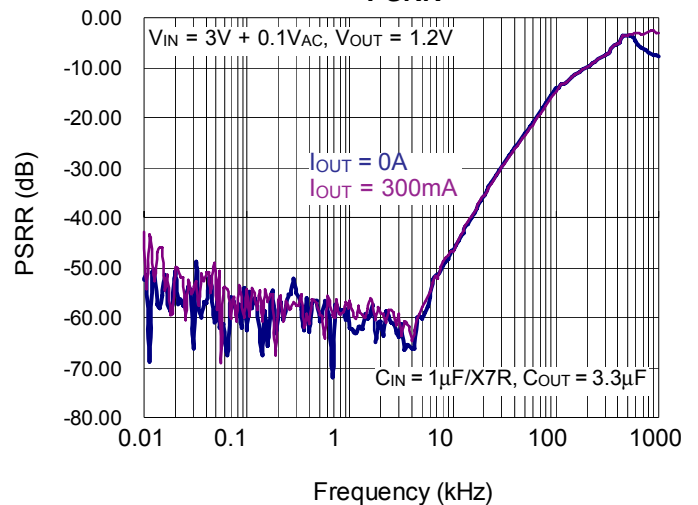

Application Information

Like any linear regulator, the RT9166B requires input and output decoupling capacitors. These capacitors must be correctly selected for good performance. Please note that linear regulators have high internal loop gains which require care in guarding against oscillation caused by insufficient decoupling capacitance.

Input Capacitor

An input capacitance of 1µF is required between the device input pin and ground directly (the capacitance may be increased without limit). The input capacitor must be located less than 1cm from the device to assure input stability. A lower ESR capacitor allows the use of less capacitance, while higher ESR type (like aluminum electrolytic) requires more capacitance.

Capacitor types (aluminum, ceramic and tantalum) can be mixed in parallel, but the total equivalent input capacitance/ ESR must be defined as above for stable operation.

There are no requirements for the ESR on the input capacitor, but tolerance and temperature coefficient must be considered when selecting the capacitor to ensure 1µF capacitance over the entire operating temperature range.

Output Capacitor

The RT9166B is designed specifically to work with very small ceramic output capacitors. The recommended minimum capacitance (temperature characteristics X7R or X5R) is 3.3µF with 10mΩ to 50mΩ range ceramic capacitor between LDO output and GND for transient stability.

Higher capacitance helps to improve the transient response. The output capacitor's ESR is critical because it forms a zero to provide phase lead which is required for loop stability.

Input-Output (Dropout) Voltage

A regulator's minimum input-to-output differential voltage (dropout voltage) determines the lowest usable supply voltage. In battery-powered systems, this determines the useful end-of-life battery voltage. Because the device uses a PMOS, its dropout voltage is a function of drain-to-

source on-resistance, $R_{DS(ON)}$, multiplied by the load current :

$$V_{DROPOUT} = V_{IN} - V_{OUT} = R_{DS(ON)} \times I_{OUT}$$

Current Limit

The RT9166B monitors and controls the PMOS gate voltage, with a minimum limit of the output current at 600mA. The output can be shorted to ground for an indefinite period of time without damaging the part.

Short-Circuit Protection

The device is short-circuit protected in the event of a peak over-current condition, such that the short-circuit control loop rapidly drives the output PMOS pass element off. Once the power pass element shuts down, the control loop will rapidly cycle the output on and off until the average power dissipation causes the thermal shutdown circuit to respond by cycling to a lower frequency. Please refer to the section on thermal information for power dissipation calculations.

Thermal Considerations

For continuous operation, do not exceed absolute maximum junction temperature. The maximum power dissipation depends on the thermal resistance of the IC package, PCB layout, rate of surrounding airflow, and difference between junction and ambient temperature. The maximum power dissipation can be calculated by the following formula :

$$P_{D(MAX)} = (T_{J(MAX)} - T_A) / \theta_{JA}$$

Where $T_{J(MAX)}$ is the maximum junction temperature, T_A is the ambient temperature, and θ_{JA} is the junction to ambient thermal resistance.

For recommended operating condition specifications of RT9166B, the maximum junction temperature is 125°C and T_A is the ambient temperature. The junction to ambient thermal resistance, θ_{JA} , is layout dependent. For SOT-89 packages, the thermal resistance, θ_{JA} , is 118°C/W on a standard JEDEC 51-7 four-layer thermal test board. The maximum power dissipation at $T_A = 25^\circ\text{C}$ can be calculated by the following formula :

$P_{D(MAX)} = (125^{\circ}\text{C} - 25^{\circ}\text{C}) / (60^{\circ}\text{C}/\text{W}) = 0.847\text{W}$ for SOT-89 package

The maximum power dissipation depends on operating ambient temperature for fixed $T_{J(MAX)}$ and thermal resistance, θ_{JA} . For RT9166B packages, the derating curve in Figure 1 allows the designer to see the effect of rising ambient temperature on the maximum power dissipation.

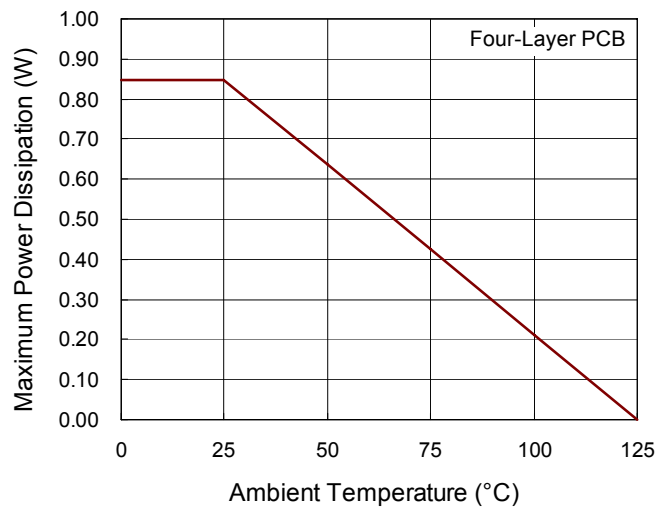
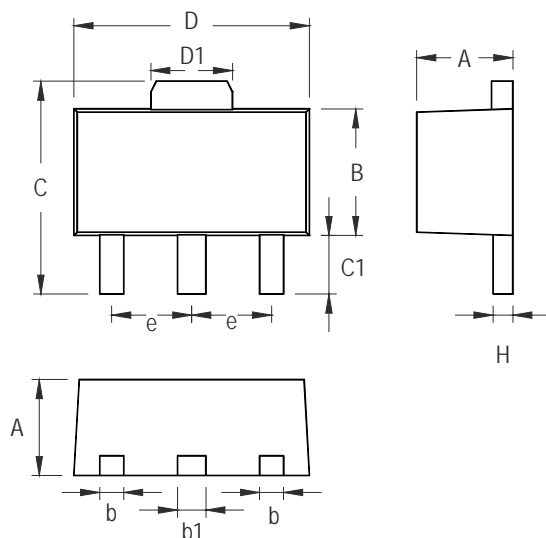

Figure 1. Derating Curve for RT9166B Package

Outline Dimension



Symbol	Dimensions In Millimeters		Dimensions In Inches	
	Min	Max	Min	Max
A	1.397	1.600	0.055	0.063
b	0.356	0.483	0.014	0.019
B	2.388	2.591	0.094	0.102
b1	0.406	0.533	0.016	0.021
C	3.937	4.242	0.155	0.167
C1	0.787	1.194	0.031	0.047
D	4.394	4.597	0.173	0.181
D1	1.397	1.753	0.055	0.069
e	1.448	1.549	0.057	0.061
H	0.356	0.432	0.014	0.017

3-Lead SOT-89 Surface Mount Package

Richtek Technology Corporation

Headquarter
 5F, No. 20, Taiyuen Street, Chupei City
 Hsinchu, Taiwan, R.O.C.
 Tel: (8863)5526789 Fax: (8863)5526611

Richtek Technology Corporation

Taipei Office (Marketing)
 5F, No. 95, Minchiuan Road, Hsintien City
 Taipei County, Taiwan, R.O.C.
 Tel: (8862)86672399 Fax: (8862)86672377
 Email: marketing@richtek.com

Information that is provided by Richtek Technology Corporation is believed to be accurate and reliable. Richtek reserves the right to make any change in circuit design, specification or other related things if necessary without notice at any time. No third party intellectual property infringement of the applications should be guaranteed by users when integrating Richtek products into any application. No legal responsibility for any said applications is assumed by Richtek.