

The S-816 Series, developed using the CMOS technology, is an external transistor type positive voltage regulator which incorporates an overcurrent protection circuit and an ON/OFF circuit. A low drop-out type regulator with an output current ranging from several hundreds of mA to 1 A can be configured with the PNP transistor driven by this IC.

Despite the features of the S-816 Series, which is low current consumption, the improvement in its transient response characteristics of the IC with a newly devised phase compensation circuit made it possible to employ the products of the S-816 Series even in applications where heavy input variation or load variation is experienced.

The S-816 Series regulator serves as an ideal power supply unit for portable devices when coupled with the small SOT-23-5 package, providing numerous outstanding features, including low current consumption. Since the S-816 Series can accommodate an input voltage of up to 16 V, it is also suitable when operating via an AC adapter.

## ■ Features

- Output voltage: 2.5 V to 6.0 V, selectable in 0.1 V step
- Input voltage: 16 V max.
- Output voltage accuracy:  $\pm 2.0\%$
- Current consumption:

During operation:	30 $\mu$ A typ., 40 $\mu$ A max.
During power-off:	1 $\mu$ A max.
- Built-in overcurrent (base current) protection circuit
- Built-in ON/OFF circuit: Ensures long battery life.
- Built-in current source (10  $\mu$ A): No need for a base-emitter resistance.
- Operation temperature range: Ta = -40°C to +85°C
- Lead-free, Sn 100%, halogen-free<sup>\*1</sup>

\*1. Refer to “**■ Product Name Structure**” for details.

## ■ Applications

- Power supply for on-board such as battery device for portable telephone, electronic notebook, PDA
- Constant voltage power supply for camera, video equipment and portable communication equipment
- Power supply for CPU
- Post-regulator for switching regulator
- Main regulator in multiple-power supply system

## ■ Package

- SOT-23-5

■ **Block Diagram**

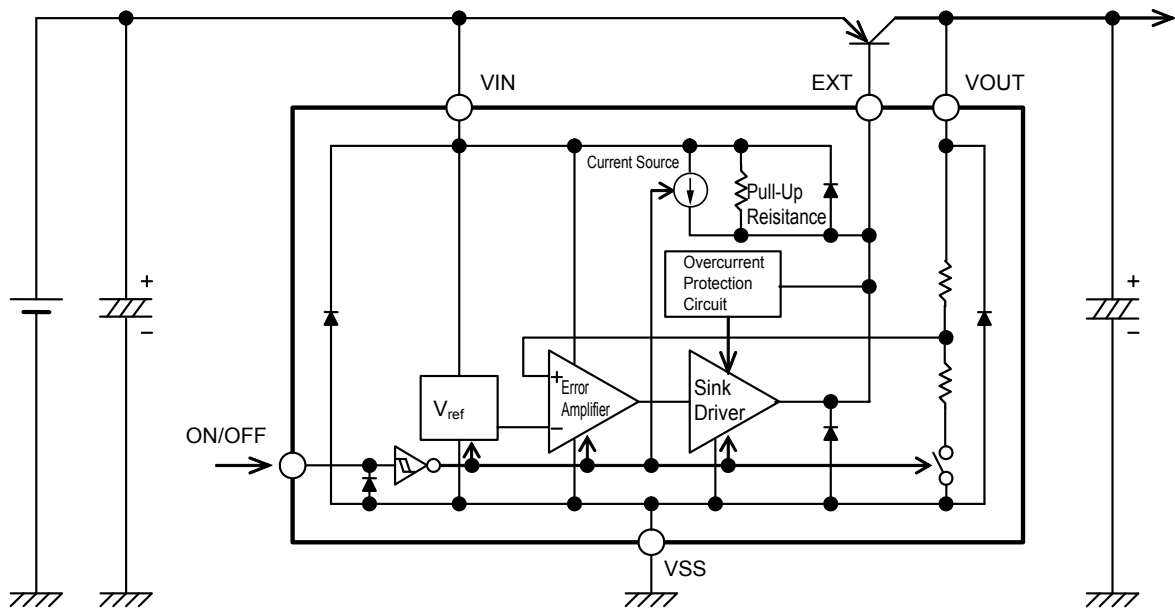

- Remark 1.** To ensure you power cutoff of the external transistor when the device is powered down, the  $EXT$  output is pulled up to  $V_{IN}$  by a pull-up resistance (approx.  $0.5\text{ M}\Omega$ ) inside the IC.
- 2.** The diode inside the IC is a parasitic diode.

**Figure 1**

■ Product Name Structure

1. Product Name

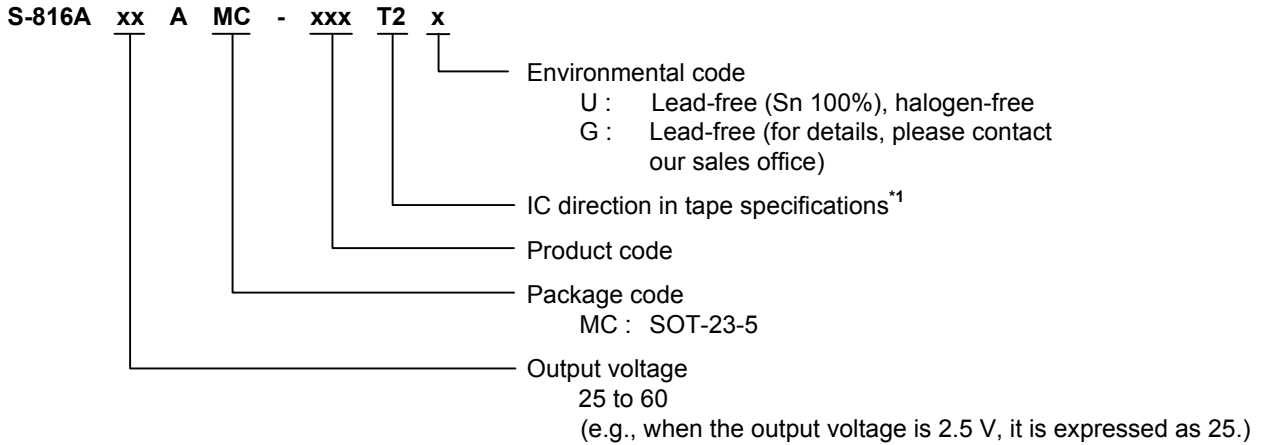

\*1. Refer to the tape drawing.

2. Package

Package Name	Drawing Code		
	Package	Tape	Reel
SOT-23-5	MP005-A-P-SD	MP005-A-C-SD	MP005-A-R-SD

3. Product Name List

Table 1

Output Voltage (V)	Product Name	Output Voltage (V)	Product Name
2.5 V±2.0%	S-816A25AMC-BAAT2x	4.3 V±2.0%	S-816A43AMC-BAST2x
2.6 V±2.0%	S-816A26AMC-BABT2x	4.4 V±2.0%	S-816A44AMC-BATT2x
2.7 V±2.0%	S-816A27AMC-BACT2x	4.5 V±2.0%	S-816A45AMC-BAUT2x
2.8 V±2.0%	S-816A28AMC-BADT2x	4.6 V±2.0%	S-816A46AMC-BAVT2x
2.9 V±2.0%	S-816A29AMC-BAET2x	4.7 V±2.0%	S-816A47AMC-BAWT2x
3.0 V±2.0%	S-816A30AMC-BAFT2x	4.8 V±2.0%	S-816A48AMC-BAXT2x
3.1 V±2.0%	S-816A31AMC-BAGT2x	4.9 V±2.0%	S-816A49AMC-BAYT2x
3.2 V±2.0%	S-816A32AMC-BAHT2x	5.0 V±2.0%	S-816A50AMC-BAZT2x
3.3 V±2.0%	S-816A33AMC-BAIT2x	5.1 V±2.0%	S-816A51AMC-BBAT2x
3.4 V±2.0%	S-816A34AMC-BAJT2x	5.2 V±2.0%	S-816A52AMC-BBBT2x
3.5 V±2.0%	S-816A35AMC-BAKT2x	5.3 V±2.0%	S-816A53AMC-BBCT2x
3.6 V±2.0%	S-816A36AMC-BALT2x	5.4 V±2.0%	S-816A54AMC-BBDT2x
3.7 V±2.0%	S-816A37AMC-BAMT2x	5.5 V±2.0%	S-816A55AMC-BBET2x
3.8 V±2.0%	S-816A38AMC-BANT2x	5.6 V±2.0%	S-816A56AMC-BBFT2x
3.9 V±2.0%	S-816A39AMC-BAOT2x	5.7 V±2.0%	S-816A57AMC-BBGT2x
4.0 V±2.0%	S-816A40AMC-BAPT2x	5.8 V±2.0%	S-816A58AMC-BBHT2x
4.1 V±2.0%	S-816A41AMC-BAQT2x	5.9 V±2.0%	S-816A59AMC-BBIT2x
4.2 V±2.0%	S-816A42AMC-BART2x	6.0 V±2.0%	S-816A60AMC-BBJT2x

Remark 1. x: G or U

2. Please select products of environmental code = U for Sn 100%, halogen-free products.

■ **Pin Configuration**

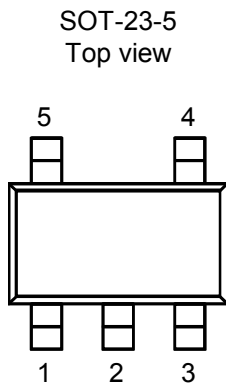

**Figure 2**

**Table 2**

Pin No.	Symbol	Description
1	EXT	Output Pin for Base-Current Control
2	VSS	GND Pin
3	ON/OFF	ON/OFF Pin (Active "H")
4	VIN	IC Power Supply Pin
5	VOUT	Output Voltage Monitoring Pin

■ Absolute Maximum Ratings

Table 3

(Ta=25°C unless otherwise specified)

Item	Symbol	Absolute Maximum Ratings	Unit
VIN Pin Voltage	V <sub>IN</sub>	V <sub>SS</sub> -0.3 to V <sub>SS</sub> +18	V
VOU Pin Voltage	V <sub>OUT</sub>	V <sub>SS</sub> -0.3 to V <sub>SS</sub> +18	V
ON/OFF Pin Voltage	V <sub>ON/OFF</sub>	V <sub>SS</sub> -0.3 to V <sub>SS</sub> +18	V
EXT Pin Voltage	V <sub>EXT</sub>	V <sub>SS</sub> -0.3 to V <sub>IN</sub> +0.3	V
EXT Pin Current	I <sub>EXT</sub>	50	mA
Power Dissipation	P <sub>D</sub>	250 (When not mounted on board)	mW
		600*1	mW
Operation Ambient Temperature Range	T <sub>opr</sub>	-40 to +85	°C
Storage Temperature	T <sub>stg</sub>	-40 to +125	°C

\*1. When mounted on board

[Mounted on board]

(1) Board size : 114.3 mm × 76.2 mm × t1.6 mm

(2) Board name : JEDEC STANDARD51-7

**Caution** The absolute maximum ratings are rated values exceeding which the product could suffer physical damage. These values must therefore not be exceeded under any conditions.

(1) When mounted on board

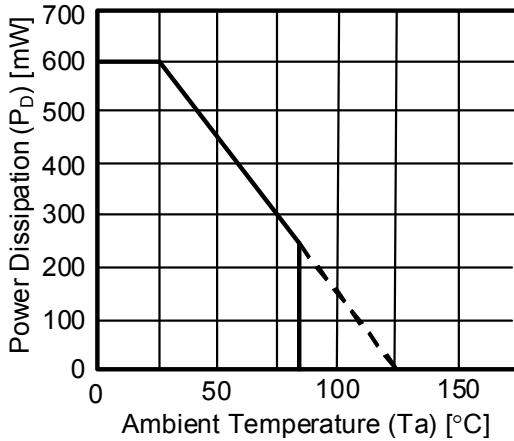

(2) When not mounted on board

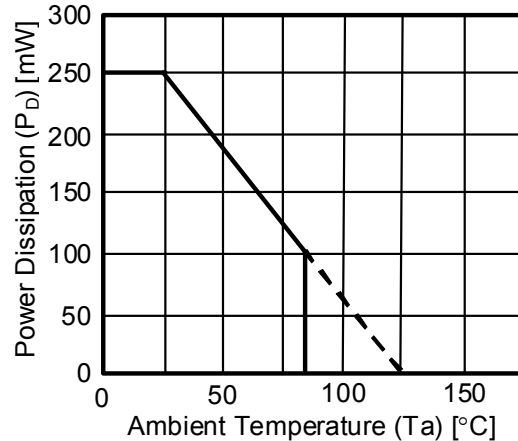

Figure 3 Power Dissipation of Package

■ **Electrical Characteristics**

**Table 4**

(Ta=25°C unless otherwise specified)

Item	Symbol	Conditions	Min.	Typ.	Max.	Unit	Test circuit
Input Voltage	$V_{IN}$	—	—	—	16	V	1
Output Voltage	$V_{OUT}$	$V_{IN}=V_{OUT}+1\text{ V}$ , $I_{OUT}=50\text{ mA}$ , $V_{ON/OFF}=\text{"H"}$	$V_{OUT}\times 0.98$	$V_{OUT}$	$V_{OUT}\times 1.02$	V	1
Maximum Output Current (PNP Output) *1	—	—	—	1	—	A	1
Drop-Out Voltage *1	$\Delta V_{drop}$	$I_{OUT}=100\text{ mA}$	—	100	—	mV	1
Load Regulation (PNP Output) *1	$\Delta V_{OUT}$	$V_{IN}=V_{OUT}+1\text{ V}$ , $1\text{ mA} < I_{OUT} < 1\text{ A}$	—	—	60	mV	1
Line Regulation (PNP Output) *1	$\frac{\Delta V_{OUT}}{V_{OUT} \bullet \Delta V_{IN}}$	$I_{OUT}=50\text{ mA}$ , $V_{OUT}+1\text{ V} < V_{IN} < 16\text{ V}$	-0.15	0.01	0.15	%/V	1
Output Voltage Temperature Coefficient	$\frac{\Delta V_{OUT}}{\Delta T_a}$	$V_{IN}=V_{OUT}+1\text{ V}$ , $I_{OUT}=50\text{ mA}$ , $V_{ON/OFF}=\text{"H"}$ , $T_a=-40\text{ to }85^\circ\text{C}$	—	$\pm 0.15$	—	mV/°C	1
Current Consumption during Operation	$I_{SS}$	$V_{IN}=V_{OUT}+1\text{ V}$ , $V_{ON/OFF}=\text{"H"}$	—	30	40	$\mu\text{A}$	1
Current Consumption during Power-off	$I_{STB}$	$V_{IN}=16\text{ V}$ , $V_{ON/OFF}=\text{"L"}$	—	—	1	$\mu\text{A}$	1
EXT Output Source Constant Current	$I_{SRC}$	$V_{IN}=V_{OUT}+1\text{ V}$ , $V_{ON/OFF}=\text{"H"}$ , $V_{EXT}=V_{OUT}$ , $V_{OUT}=V_{OUT}\times 0.95$	—	-10	—	$\mu\text{A}$	2
EXT Output Pull-Up Resistance	$R_{UP}$	$V_{IN}=16\text{ V}$ , $V_{ON/OFF}=\text{"L"}$	0.25	0.50	1.00	M $\Omega$	2
EXT Output Sink Current	$I_{SINK}$	$V_{IN}=V_{OUT}+1\text{ V}$ , $V_{ON/OFF}=\text{"H"}$ , $V_{OUT}=V_{OUT}\times 0.95$	—	10	—	mA	2
Leakage Current during EXT Output Off	$I_{OFF}$	$V_{IN}=V_{EXT}=V_{OUT}+1\text{ V}$ , $V_{OUT}=0\text{ V}$ , $V_{ON/OFF}=\text{"L"}$	—	—	0.1	$\mu\text{A}$	2
EXT Output Sink Overcurrent Set Value	$I_{MAX}$	$V_{IN}=V_{EXT}=7\text{ V}$ , $V_{ON/OFF}=\text{"H"}$ , $V_{OUT}=V_{OUT}\times 0.95$	12	16	20	mA	2
ON/OFF Pin Input Voltage	$V_{SH}$	$V_{IN}=V_{OUT}+1\text{ V}$ , $V_{OUT}=0\text{ V}$ , Check $V_{EXT}=\text{"L"}$	2.4	—	—	V	3
	$V_{SL}$	$V_{IN}=V_{OUT}+1\text{ V}$ , $V_{OUT}=0\text{ V}$ , Check $V_{EXT}=\text{"H"}$	—	—	0.3		
ON/OFF Pin Input Current	$I_{SH}$	$V_{ON/OFF}=V_{OUT}+1\text{ V}$	—	—	0.1	$\mu\text{A}$	2
	$I_{SL}$	$V_{ON/OFF}=0\text{ V}$	—	—	-0.1		

\*1. The characteristics vary with the associated external components.  
 The characteristics given above are those obtained when the IC is combined with A TOSHIBA Semiconductor & Storage Products Company 2SA1213-Y for the PNP transistor and a 10  $\mu\text{F}$  tantalum capacitor for the output capacitor ( $C_L$ ).

■ Test Circuits

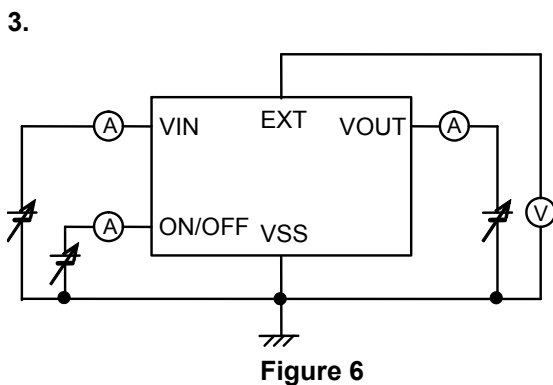
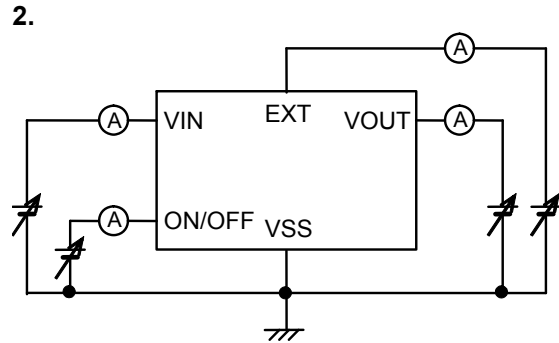
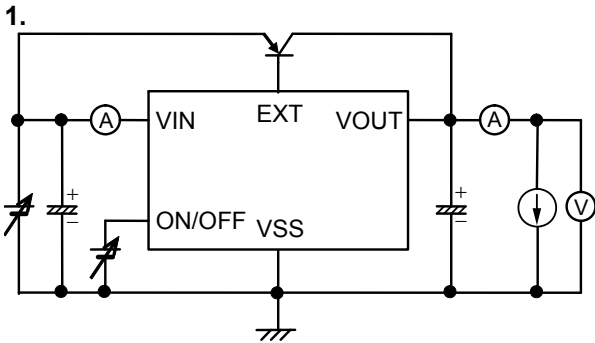

■ **Operation**

**1. Basic Operation**

**Figure 7** shows the block diagram of the S-816 Series.

The error amplifier compares the reference voltage ( $V_{ref}$ ) with feedback voltage ( $V_{fb}$ ), which is the output voltage resistance-divided by feedback resistors ( $R_A$  and  $R_B$ ). It maintains a constant output voltage that is not susceptible to an input voltage variation or temperature variation to regulate the base current of the external PNP transistor.

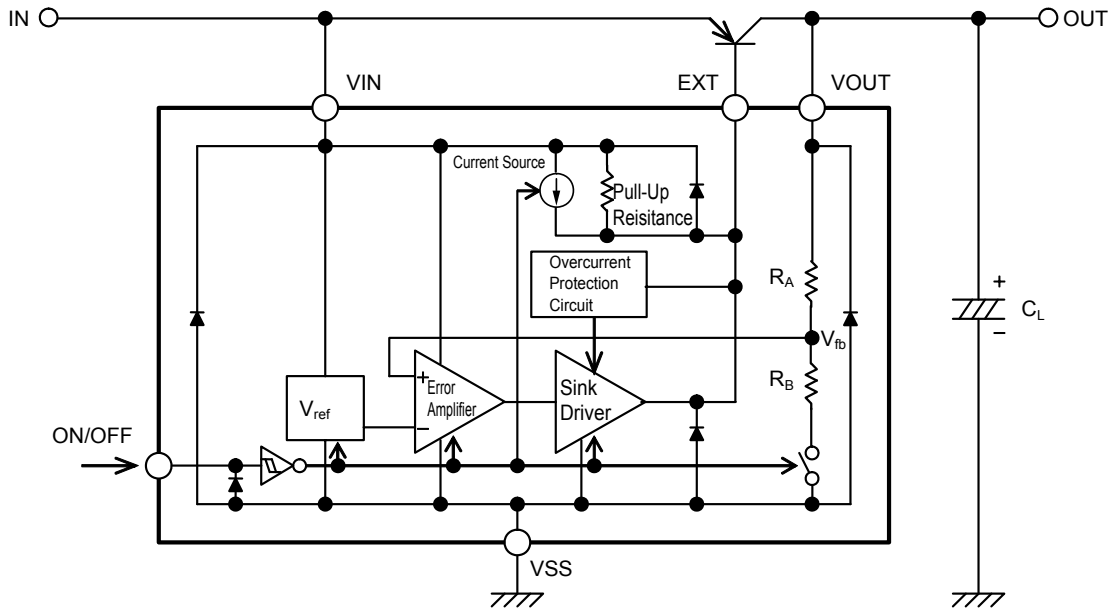

**Remark** The diode inside the IC is a parasitic diode.

**Figure 7**

**2. Internal Circuits**

**2.1. ON/OFF Pin**

This pin starts and stops the regulator.

When the ON/OFF pin is set to OFF level, the entire internal circuits stop operating, and the  $V_{IN}$  voltage appears through the EXT pin, prodding the external PNP transistor to off, reducing current consumption significantly. In this condition, the EXT pin is pulled up to  $V_{IN}$  by a pull-up resistance (approx.  $0.5\text{ M}\Omega$ ) inside the IC in order to ensure you power cut off of the external PNP transistor.

The ON/OFF pin is configured as shown in **Figure 8**. Since neither pull-up or pull-down is performed internally, please avoid using the pin in a floating state. Also, be sure to refrain from applying a voltage of 0.3 V to 2.4 V to this pin lest the current consumption increase. When this ON/OFF pin is not used, leave it coupled to the  $V_{IN}$  pin.

**Table 5**

ON/OFF Pin	Internal Circuit	EXT Pin Voltage	VOUT Pin Voltage
"H": ON	Operate	$V_{IN} - V_{BE}$	Set value
"L": OFF	Stop	$V_{IN}$	Hi-Z

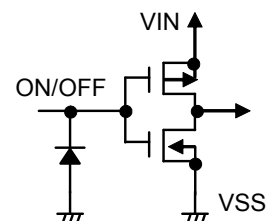

**Figure 8**



## 2.2. Overcurrent Protection Circuit

The overcurrent protection function of the S-816 Series monitors the EXT pin sink current (base current of the external PNP transistor) with an overcurrent protection circuit incorporated in the IC, and limits that current (EXT pin sink current).

As the load current increases, the EXT pin sink current (base current of the external PNP transistor) also grows larger to maintain the output voltage. The overcurrent protection circuit clamps and limits the EXT pin sink current to the EXT output sink overcurrent set value ( $I_{MAX}$ ) in order to prevent it from increasing beyond that value.

The load current at which the overcurrent protection function works is represented by the following equation:

$$I_{OUT\_MAX} = I_{MAX} \times h_{FE}$$

In this case,  $h_{FE}$  is the DC amplification factor of the external PNP transistor.

$I_{OUT\_MAX}$  represents the maximum output current of this regulator. If it is attempted to obtain a higher load current, the output voltage will fall.

Note that within the overcurrent protection function of this IC, the external PNP transistor may not be able to be protected from collector overcurrents produced by an EXT-GND short-circuiting or other phenomenon occurring outside the IC. To protect the external PNP transistor from such collector overcurrents, it will be necessary to choose a transistor with a larger power dissipation than  $I_{OUT\_MAX} \times V_{IN}$ , or to add an external overcurrent protection circuit. With regard to this external overcurrent protection circuit, refer to "**1. Overcurrent Protection Circuit**" in "**Application Circuits**".

## 2.3. Phase Compensation Circuit

The S-816 Series performs phase compensation with a phase compensation circuit, incorporated in the IC, and the ESR (Equivalent Series Resistance) of an output capacitor, to secure stable operation even in the presence of output load variation. A uniquely devised phase compensation circuit has resulted in improved transient response characteristics of the IC, while preserving the same feature of low current consumption. This feature allows the IC to be used in applications where the input variation or load variation is heavy.

Because the S-816 Series is designed to perform the phase compensation, utilizing the ESR of an output capacitor, such output capacitor ( $C_L$ ) should always be placed between VOUT and VSS. Since each capacitor to be employed has an optimum range of their own characteristics, be sure to choose components for the IC with your all attention. For details, refer to "**Selection of Associated External Components**".

■ **Selection of Associated External Components**

**1. External PNP Transistor**

Select an external transistor according to the conditions of input voltage, output voltage, and output current. A low-saturation voltage PNP transistor with "h<sub>FE</sub>" ranging from 100 to 300 will be suitable for this IC.

The parameters for selection of the external PNP transistor include the maximum collector-base voltage, the maximum collector-emitter voltage, the DC amplification factor (h<sub>FE</sub>), the maximum collector current and the collector dissipation.

The maximum collector-base voltage and the maximum collector-emitter voltage are determined by the input voltage range in each specific application to be employed. You may select a transistor with an input voltage at least several volts higher than the expected maximum input voltage.

The DC amplification factor (h<sub>FE</sub>) affects the maximum output current that can be supplied to the load. With an internal overcurrent protection circuit of this IC, the base current is clamped, and will not exceed the overcurrent set value (I<sub>MAX</sub>). Select a transistor which is capable of delivering the required maximum output current to the intended application, with hfe and maximum collector current. (Refer to "■ **Overcurrent Protection Circuit**")

Likewise, select a transistor, based on the maximum output current and the difference between the input and output voltages, with due attention to the collector dissipation.

**2. Output Capacitor (C<sub>L</sub>)**

The S-816 Series performs phase compensation by an internal phase compensation circuit of IC, and the ESR (Equivalent Series Resistance) of an output capacitor for to secure stable operation even in the presence of output load variation. Therefore, always place a capacitor (C<sub>L</sub>) of 4.7 μF or more between VOUT and VSS.

For stable operation of the S-816 Series, it is essential to employ a capacitor with an ESR having optimum range. Whether an ESR is larger or smaller than that optimum range (approximately 0.1 Ω to 5 Ω), this could produce an unstable output, and cause a possibility of oscillations. For this reason, a tantalum electrolytic capacitor is recommended.

When a ceramic capacitor or an OS capacitor having a low ESR is selected, it will be necessary to connect an additional resistance that serves for the ESR in series with the output capacitor, as illustrated in **Figure 9**. The resistance value that needs to be added will be from 0.1 Ω to 5 Ω, but this value may vary depends on the service conditions, and should be defined through careful evaluation in advance. In general, our recommendation is 0.3 Ω or so.

An aluminum electrolytic capacitor tends to produce oscillations as its ESR increases at a low temperature. Beware of this case. When this type of capacitor is employed, make thorough evaluation of it, including its temperature characteristics.

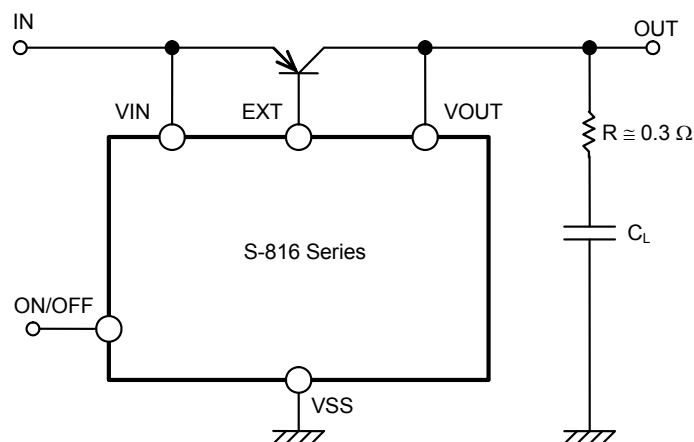

**Figure 9**

**Caution** The above connection diagram and constant will not guarantee successful operation. Perform through evaluation using the actual application to set the constant.

■ Standard Circuit

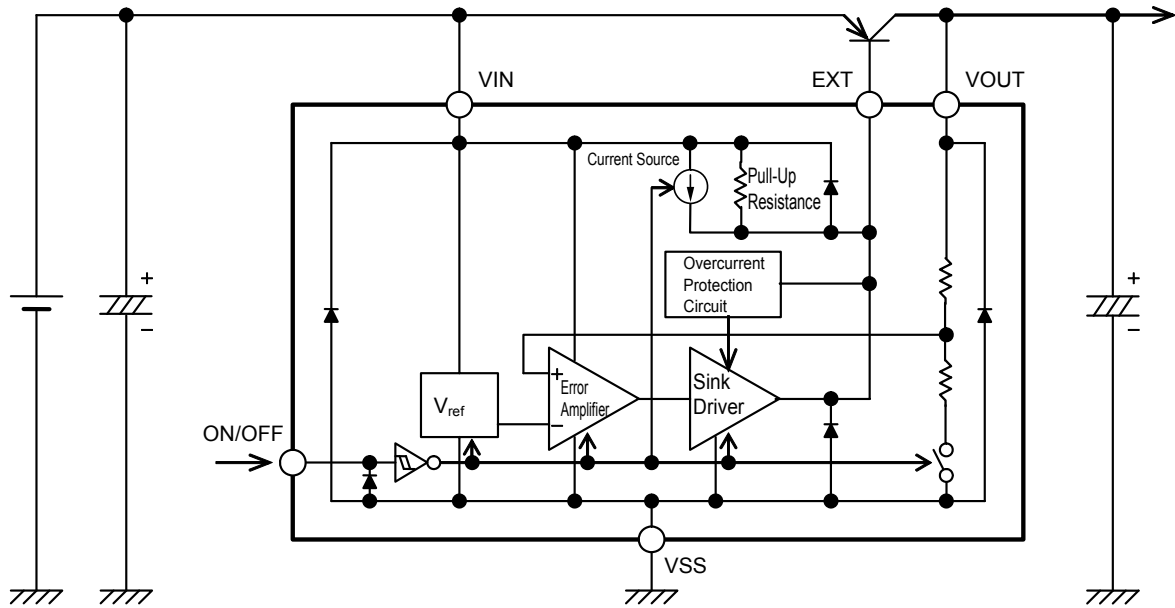

**Remark** The diode inside the IC is a parasitic diode.

Figure 10

**Caution** The above connection diagram does not guarantee correct operation. Perform sufficient evaluation using the actual application to set the constant.

■ **Precautions**

- The overcurrent protection function of this IC detects and limits the sink current at the EXT pin inside the IC. Therefore, it does not work on collector overcurrents which are caused by an EXT-GND short-circuiting or other phenomenon outside the IC. To protect the external PNP transistor from collector overcurrents perfectly, it is necessary to provide another external overcurrent protection circuit.
- This IC performs phase compensation by using an internal phase compensator circuit and the ESR of an output capacitor. Therefore, always place a capacitor of 4.7  $\mu\text{F}$  or more between VOUT and VSS. A tantalum type capacitor is recommended for this purpose. Moreover, to secure stable operation of the S-816 Series, it will be necessary to employ a capacitor having an ESR (Equivalent Series Resistance) covered in a certain optimum range (0.1  $\Omega$  to 5  $\Omega$ ). Whether an ESR is larger or smaller than that optimum range, this could result in an unstable output, and cause a possibility of oscillations. Select a capacitor through careful evaluation made according to the actual service conditions.
- Overshoot may occur in the output voltage momentarily if the voltage is rapidly raised at power-on or when the power supply fluctuates. Sufficiently evaluate the output voltage at power-on with the actual device.
- Do not apply an electrostatic discharge to this IC that exceeds the performance ratings of the built-in electrostatic protection circuit.
- Make sure that the power dissipation inside the IC due to the EXT output sink current (especially at a high temperature) will not surpass the power dissipation of the package.
- ABLIC Inc. claims no responsibility for any disputes arising out of or in connection with any infringement by products including this IC of patents owned by a third party.

**Application Circuits**

**1. Overcurrent Protection Circuit**

**Figure 11** shows a sample of overcurrent protection implemented with an external circuit connected. The internal overcurrent protection function of the S-816 Series is designed to detect the sink current (base current of the PNP transistor) at the EXT pin, therefore it may not be able to protect the external PNP transistor from collector overcurrents caused by an EXT-GND short-circuiting or other phenomenon occurring outside the IC.

This sample circuit activates the regulator intermittently against collector overcurrents, thereby suppressing the heat generation of the external PNP transistor.

The duty of the on-time and off-time of the intermittent operation can be regulated through an external component.

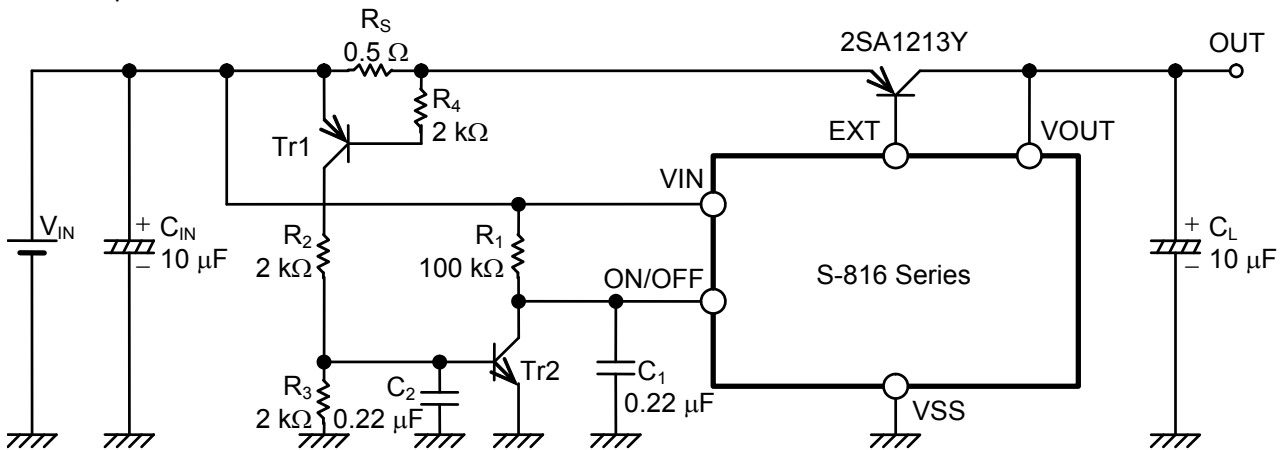

**Figure 11**

**Caution** The above connection diagram and constant will not guarantee successful operation. Perform through evaluation using the actual application to set the constant.

S-816A30AMC ( $V_{IN}=4\text{ V}$ )

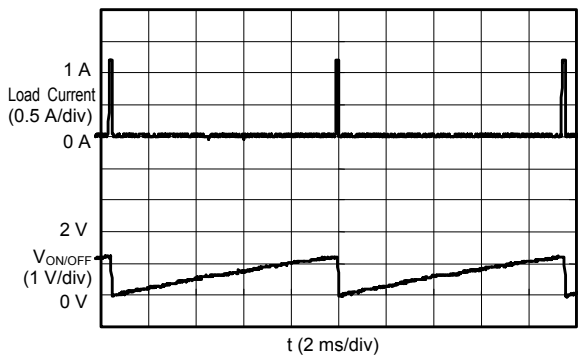

S-816A30AMC ( $V_{IN}=4\text{ V}$ )

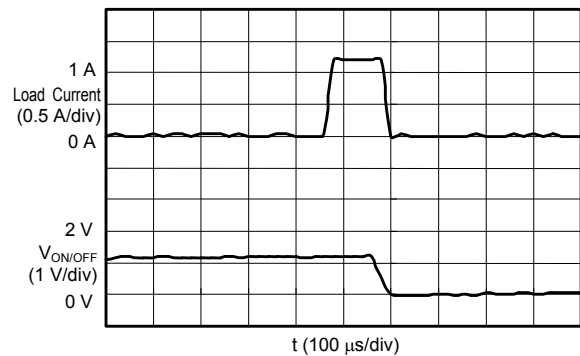

**Figure 12** Output Current Waveforms during Intermittent Operation Prompted by Load Short-Circuiting

The detection of the overcurrent is done by the sense resistance ( $R_S$ ) and the PNP transistor (Tr1). When Tr1 comes on, triggered by a voltage drop of  $R_S$ , the NPN transistor (Tr2) also comes on, according to the time constants of the capacitor ( $C_2$ ) and resistance ( $R_2$ ). This causes the ON/OFF pin to turn to OFF level, and the regulating operation to stop, and interrupting the current to the load. When the load current is cut off, the voltage drop of  $R_S$  stops. This makes Tr1 off again, and also makes the NPN transistor (Tr2) off. In this condition, the ON/OFF pin returns to ON level, according to the time constants of the capacitor ( $C_1$ ) and resistance ( $R_1$ ). This delay time in which ON/OFF pin returns to ON level from OFF level is the time in which the load current remains cut off.

If an overcurrent flows again after the ON/OFF pin has assumed ON level following the delay time and the regulating operation has been restarted, the circuit will again suspend the regulating operation and resume the intermittent operation. This intermittent operation will be continued till the overcurrent is eliminated, and once the overcurrent disappears, the normal operation will be restored. The overcurrent detection value ( $I_{OUT\_MAX}$ ) is represented by the following equation:

$$I_{OUT\_MAX} = |V_{BE1}| / R_S$$

In this case,  $R_S$  denotes the resistance value of the sense resistance, and  $V_{BE1}$  denotes the base-emitter saturation voltage of Tr1. For the PNP transistor (Tr1) and the NPN transistor (Tr2), try to select those of small-signal type that offer a sufficient withstand voltage against the input voltage ( $V_{IN}$ ). The on-time ( $t_{ON}$ ) and the off-time ( $t_{OFF}$ ) of the intermittent operation are broadly expressed by the following equations:

$$t_{ON} = -1 \times C_2 \times R_2 \times L_N ( 1 - ( V_{BE2} \times ( 1 + R_2 / R_3 ) ) / ( V_{IN} - V_{BE1} ) )$$

$$t_{OFF} = -1 \times C_1 \times R_1 \times L_N ( 1 - V_{SH} / V_{IN} )$$

In this case,  $V_{BE2}$  denotes the base-emitter saturation voltage of Tr2,  $V_{IN}$  denotes the input voltage, and  $V_{SH}$  denotes the inversion voltage ("L"→"H") of the ON/OFF pin. Set the on-time value that does not cause the overcurrent protection to be activated by a rush current to the load capacitor. Then, compute the ratio between the on-time and the off-time from the maximum input voltage of the appropriate application and the power dissipation of the external PNP transistor, and decide the off-time with reference to the on-time established earlier. Take the equation above as a rough guide, because the actual on-time ( $t_{ON}$ ) and off-time ( $t_{OFF}$ ) should be defined and checked using the utilizing components.

**2. External Adjustment of Output Voltage**

The S-816 Series allows you to adjust the output voltage or to set its value over the output voltage range (6 V) of the products of this series, when external resistances  $R_A$ ,  $R_B$  and capacitor  $C_C$  are added, as illustrated in **Figure 13**. Moreover, a temperature gradient can be obtained by inserting a thermistor or other element in series with external resistances  $R_A$  and  $R_B$ .

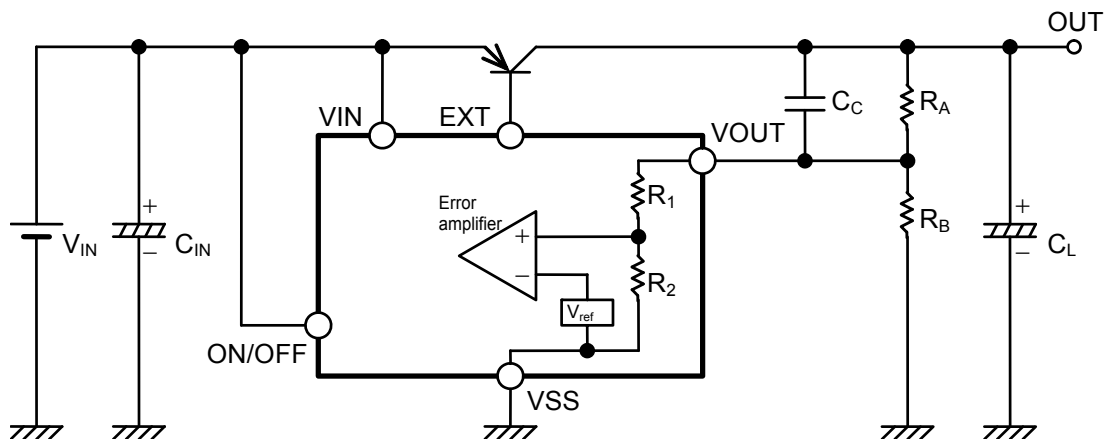

**Figure 13**

The S-816 Series has an internal impedance resulting from  $R_1$  and  $R_2$  between the VOUT and the VSS pin, as shown in **Figure 13**. Therefore, the influence of the internal resistances ( $R_1$ ,  $R_2$ ) of the IC has to be taken into consideration in defining the output voltage (OUT).

The output voltage (OUT) is expressed by the following equation:

$$\text{OUT} = V_{\text{OUT}} + V_{\text{OUT}} \times R_A \div (R_B // R_i)$$

\*1. "/" denotes a combined resistance in parallel.

In this case,  $V_{\text{OUT}}$  is the output voltage value of the S-816 Series,  $R_A$  and  $R_B$  is the resistance values of the external resistances, and  $R_i$  is the resistance value ( $R_1+R_2$ ) of the internal resistances in the IC.

The accuracy of the output voltage (OUT) is determined by the absolute accuracy of external connecting resistances  $R_A$  and  $R_B$ , the output voltage accuracy ( $V_{\text{OUT}} \pm 2.0\%$ ) of the S-816 Series, and deviations in the absolute value of the internal resistance ( $R_i$ ) in the IC.

The maximum value (OUTmax) and the minimum value (OUTmin) of the output voltage (OUT), including deviations, are expressed by the following equations:

$$\text{OUTmax} = V_{\text{OUT}} \times 1.02 + V_{\text{OUT}} \times 1.02 \times R_{A\text{max}} \div (R_{B\text{min}} // R_{i\text{min}})$$

$$\text{OUTmin} = V_{\text{OUT}} \times 0.98 + V_{\text{OUT}} \times 0.98 \times R_{A\text{min}} \div (R_{B\text{max}} // R_{i\text{max}})$$

Where  $R_{A\text{max}}$ ,  $R_{A\text{min}}$ ,  $R_{B\text{max}}$  and  $R_{B\text{min}}$  denote the maximum and minimum of the absolute accuracy of external resistances  $R_A$  and  $R_B$ , and  $R_{i\text{max}}$  and  $R_{i\text{min}}$  denote the maximum and minimum deviations of the absolute value of the internal resistance ( $R_i$ ) in the IC, respectively.

The deviations in the absolute value of internal resistance ( $R_i$ ) in the IC vary with the output voltage set value of the S-816 Series, and are broadly classified as follows:

- Output voltage ( $V_{\text{OUT}}$ ) 2.5 V to 2.7 V  $\Rightarrow$  3.29 M $\Omega$  to 21.78 M $\Omega$
- Output voltage ( $V_{\text{OUT}}$ ) 2.8 V to 3.1 V  $\Rightarrow$  3.29 M $\Omega$  to 20.06 M $\Omega$
- Output voltage ( $V_{\text{OUT}}$ ) 3.2 V to 3.7 V  $\Rightarrow$  2.23 M $\Omega$  to 18.33 M $\Omega$
- Output voltage ( $V_{\text{OUT}}$ ) 3.8 V to 5.1 V  $\Rightarrow$  2.23 M $\Omega$  to 16.61 M $\Omega$
- Output voltage ( $V_{\text{OUT}}$ ) 5.2 V to 6.0 V  $\Rightarrow$  2.25 M $\Omega$  to 14.18 M $\Omega$

If a value of  $R_i$  given by the equation shown below is taken in calculating the output voltage (OUT), a median voltage deviation of the output voltage (OUT) will be obtained.

$$R_i = 2 \div (1 \div (\text{Maximum value of internal resistance of IC}) + 1 \div (\text{Minimum value of internal resistance of IC}))$$

The closer the output voltage (OUT) and the output voltage set value ( $V_{\text{OUT}}$ ) of the IC are brought to each other, the more the accuracy of the output voltage (OUT) remains immune to deviations in the absolute accuracy of external resistances ( $R_A$ ,  $R_B$ ) and the absolute value of the internal resistance ( $R_i$ ) of the IC. In particular, to suppress the influence of deviations in the internal resistance ( $R_i$ ), the resistance values of external resistances ( $R_A$ ,  $R_B$ ) need to be limited to a much smaller value than that of the internal resistance ( $R_i$ ). However, since reactive current flows through the external resistances ( $R_A$ ,  $R_B$ ), there is a tradeoff between the accuracy of the output voltage (OUT) and the reactive current. This should be taken into consideration, according to the requirements of the intended application.

Note that when larger value (more than 1 M $\Omega$ ) is taken for the external resistances ( $R_A$ ,  $R_B$ ), IC is vulnerable to external noise. Check the influence of this value well with the actual application.

Furthermore, add a capacitor  $C_C$  in parallel to the external resistance  $R_A$  in order to avoid output oscillations and other types of instability. (Refer to **Figure 13**)

Make sure that the capacitance value of  $C_C$  is larger than the value given by the following equation:

$$C_C[\text{F}] \geq 1 \div (2 \times \pi \times R_A[\Omega] \times 6000)$$

**Caution** The above connection diagram and constant will not guarantee successful operation. Perform through evaluation using the actual application to set the constant.

■ **Characteristics (Typical Data)**

**1. Input Voltage ( $V_{IN}$ ) - Output Voltage ( $V_{OUT}$ )**

$V_{IN}-V_{OUT}$   
 S-816A30AMC ( $I_{OUT}=50\text{ mA}$ )

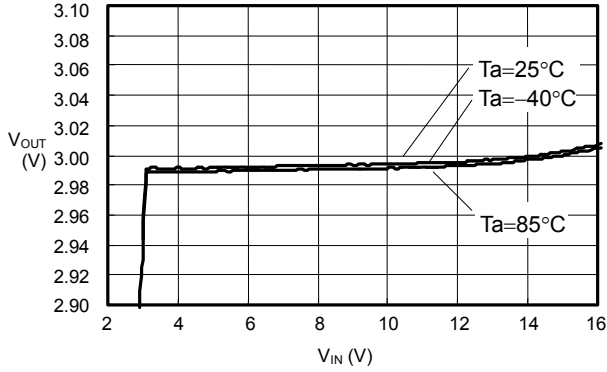

$V_{IN}-V_{OUT}$   
 S-816A50AMC ( $I_{OUT}=50\text{ mA}$ )

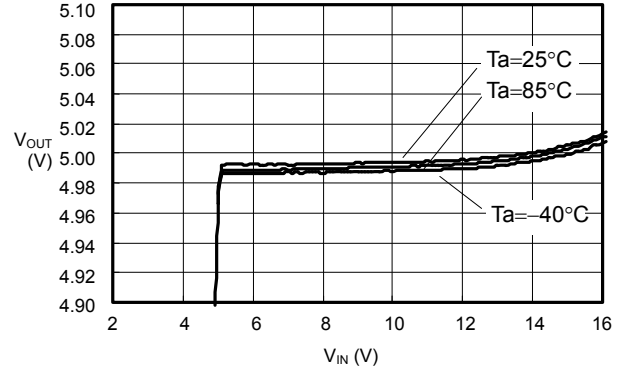

$V_{IN}-V_{OUT}$   
 S-816A30AMC ( $T_a=25^\circ\text{C}$ )

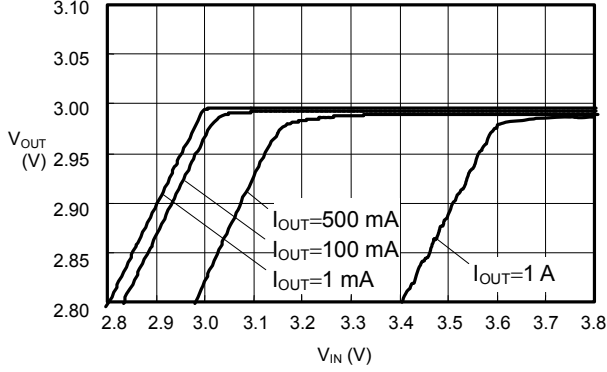

$V_{IN}-V_{OUT}$   
 S-816A50AMC ( $T_a=25^\circ\text{C}$ )

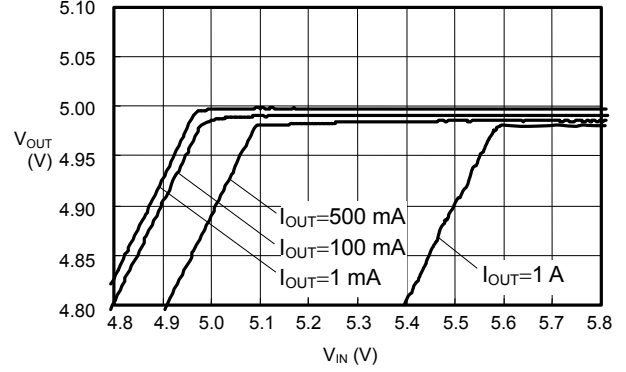

**2. Output Current ( $I_{OUT}$ ) - Output Voltage ( $V_{OUT}$ )**

$I_{OUT}-V_{OUT}$   
 S-816A30AMC ( $V_{IN}=4\text{ V}$ )

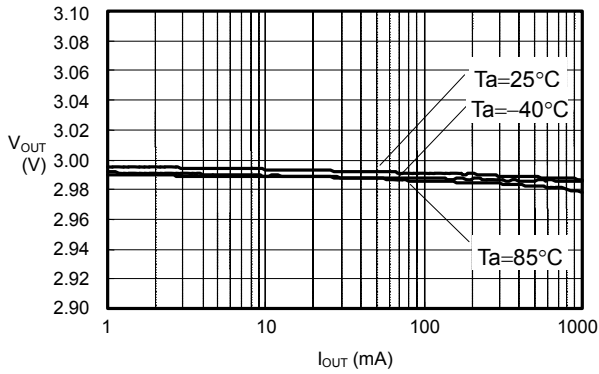

$I_{OUT}-V_{OUT}$   
 S-816A50AMC ( $V_{IN}=6\text{ V}$ )

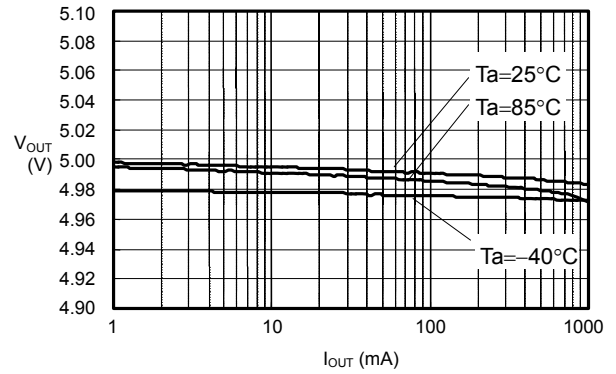



3. Temperature (Ta) - Output Voltage (V<sub>OUT</sub>)

Ta-V<sub>OUT</sub>  
S-816A30AMC (V<sub>IN</sub>=4 V, I<sub>OUT</sub>=50 mA)

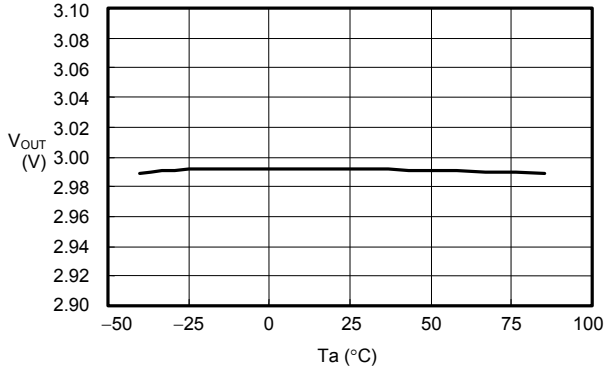

Ta-V<sub>OUT</sub>  
S-816A50AMC (V<sub>IN</sub>=6 V, I<sub>OUT</sub>=50 mA)

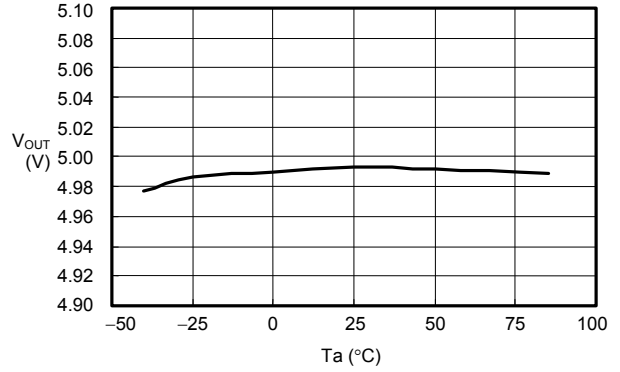

4. Input Voltage (V<sub>IN</sub>) - Current Consumption (I<sub>SS</sub>)

V<sub>IN</sub>-I<sub>SS</sub>  
S-816A30AMC (V<sub>ON/OFF</sub>="H")

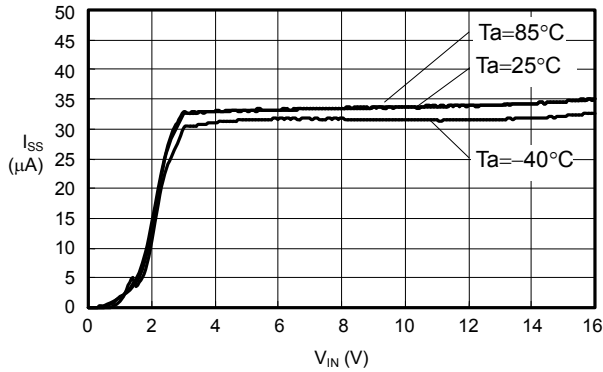

5. Input Voltage (V<sub>IN</sub>) - EXT Output Sink Overcurrent Set Value (I<sub>MAX</sub>)

V<sub>IN</sub>-I<sub>MAX</sub>  
S-816A30AMC

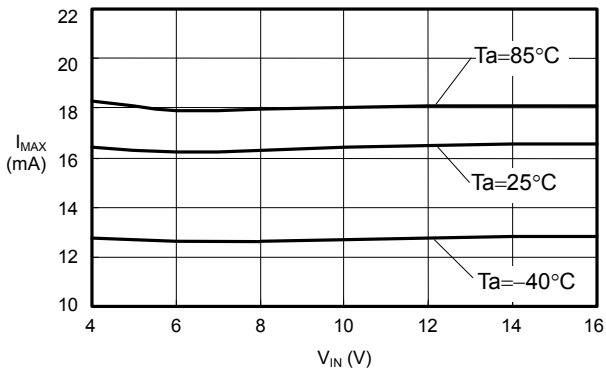

**6. Input Voltage ( $V_{IN}$ ) - ON/OFF Pin Input Voltage ( $V_{SH}$ ,  $V_{SL}$ )**

$V_{IN}-V_{SH}$   
 S-816A30AMC

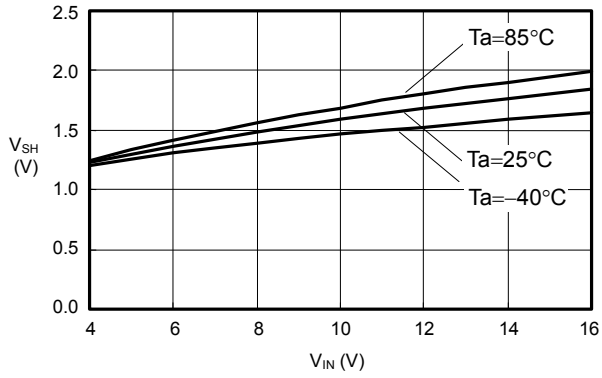

$V_{IN}-V_{SL}$   
 S-816A30AMC

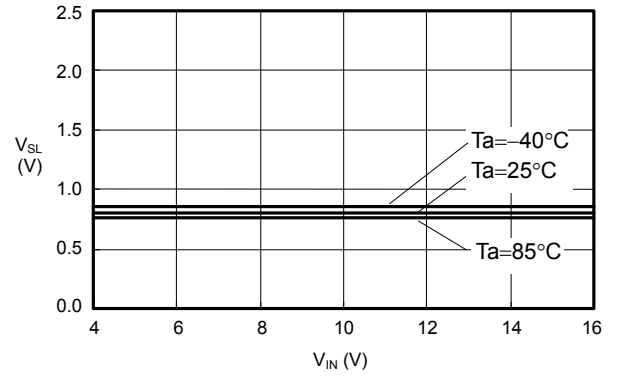

■ Transient Response Characteristics (Typical Data)

1. Input Transient Response Characteristics (Power-on  $V_{IN}=0\text{ V} \rightarrow V_{OUT}+1\text{ V}$ ,  $I_{OUT}=0\text{ A}$ ,  $C_L=10\text{ }\mu\text{F}$ )

S-816A30AMC ( $V_{IN}=0\text{ V} \rightarrow 4\text{ V}$ )

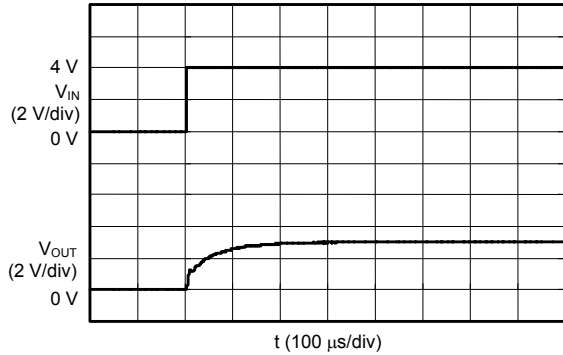

S-816A50AMC ( $V_{IN}=0\text{ V} \rightarrow 6\text{ V}$ )

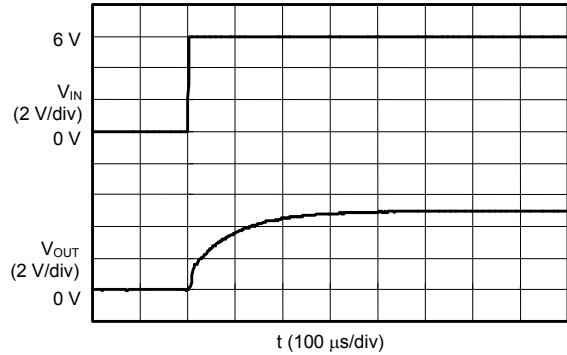

2. Input Transient Response Characteristics (Supply voltage variation  $V_{IN}=V_{OUT}+1\text{ V} \leftrightarrow V_{OUT}+2\text{ V}$ ,  $C_L=10\text{ }\mu\text{F}$ )

S-816A30AMC ( $I_{OUT}=10\text{ mA}$ )



S-816A30AMC ( $I_{OUT}=300\text{ mA}$ )

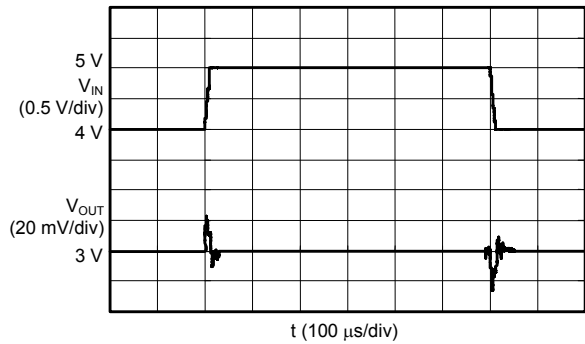

S-816A50AMC ( $I_{OUT}=10\text{ mA}$ )

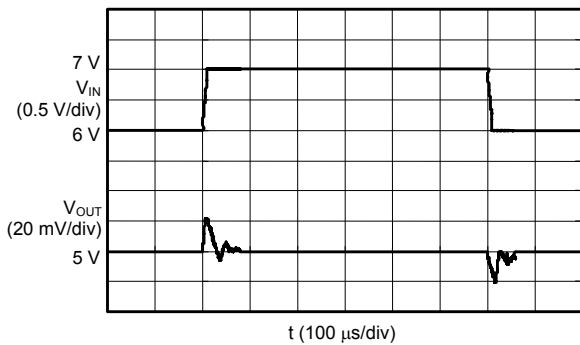

S-816A50AMC ( $I_{OUT}=300\text{ mA}$ )

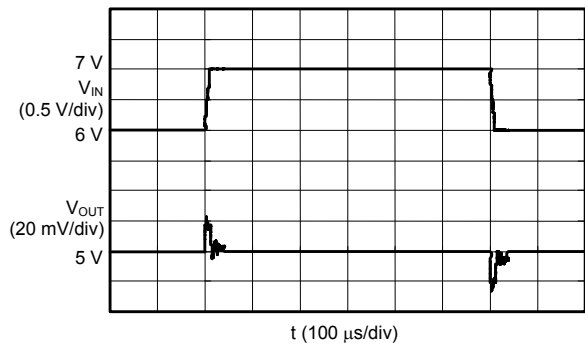

**3. Load Transient Response Characteristics (Power-on  $I_{OUT}=1\text{ mA} \leftrightarrow 100\text{ mA}$ ,  $C_L=10\text{ }\mu\text{F}$ )**

S-816A30AMC ( $V_{IN}=4\text{ V}$ )

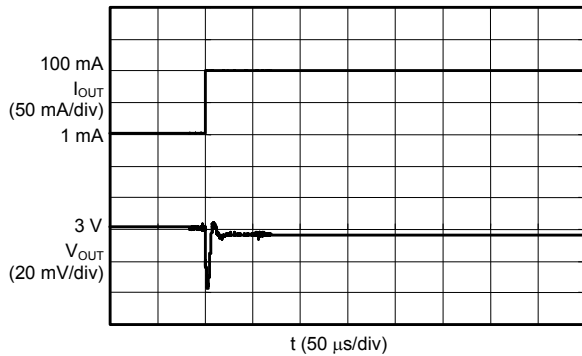

S-816A30AMC ( $V_{IN}=4\text{ V}$ )

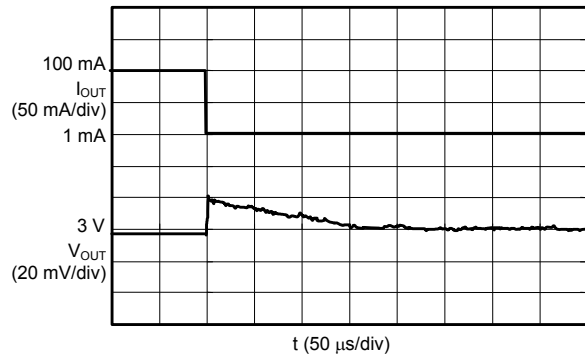

S-816A50AMC ( $V_{IN}=6\text{ V}$ )

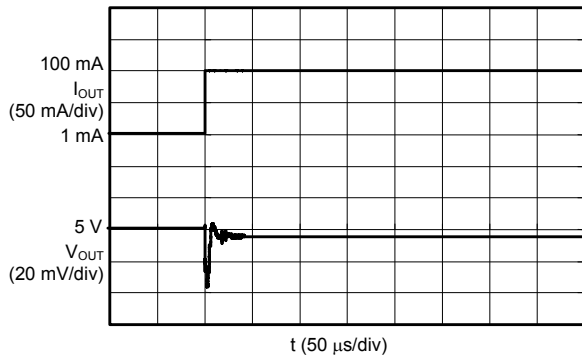

S-816A50AMC ( $V_{IN}=6\text{ V}$ )

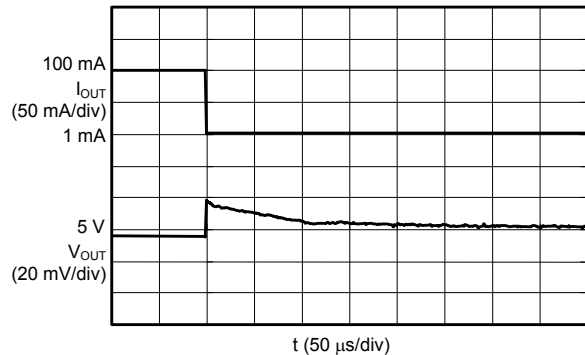

**4. ON/OFF Pin Transient Response Characteristics ( $V_{ON/OFF}=0\text{ V} \rightarrow V_{IN}$ ,  $I_{OUT}=0\text{ A}$ ,  $C_L=10\text{ }\mu\text{F}$ )**

S-816A30AMC ( $V_{IN}=4\text{ V}$ )

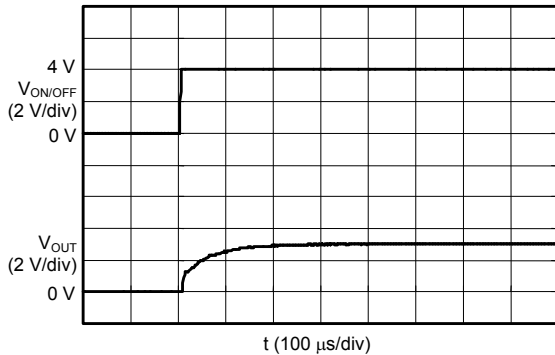

S-816A50AMC ( $V_{IN}=6\text{ V}$ )

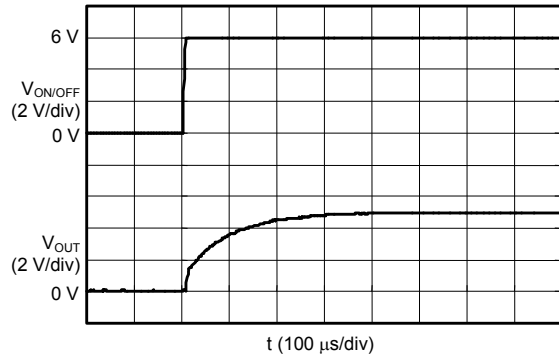

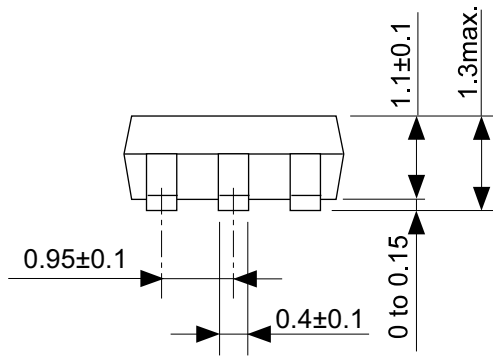
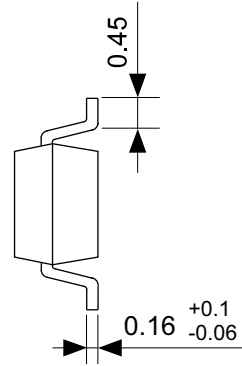
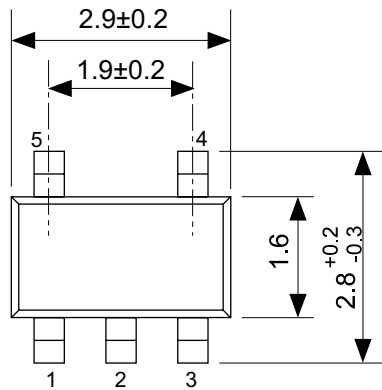

No. MP005-A-P-SD-1.3

TITLE	SOT235-A-PKG Dimensions
No.	MP005-A-P-SD-1.3
ANGLE	
UNIT	mm
<b>ABLIC Inc.</b>	

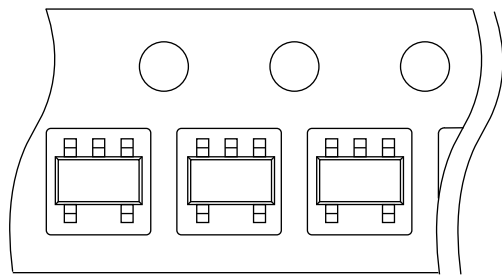
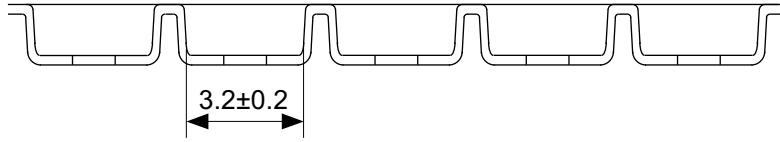
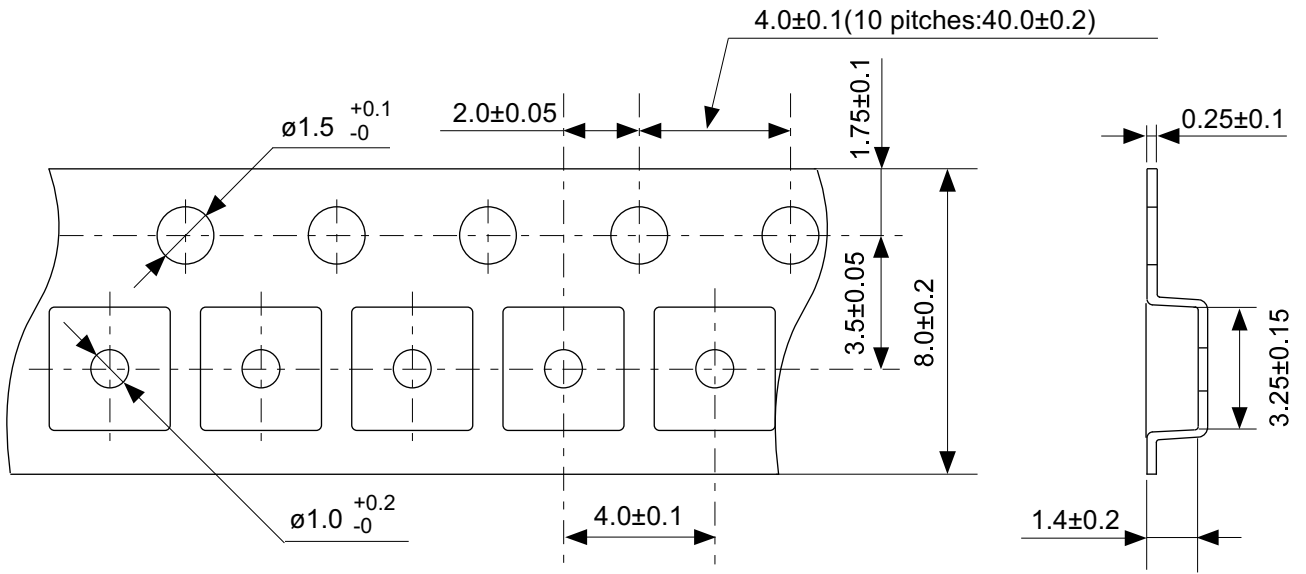

Feed direction →

No. MP005-A-C-SD-2.1

TITLE	SOT235-A-Carrier Tape
No.	MP005-A-C-SD-2.1
ANGLE	
UNIT	mm
<b>ABLIC Inc.</b>	

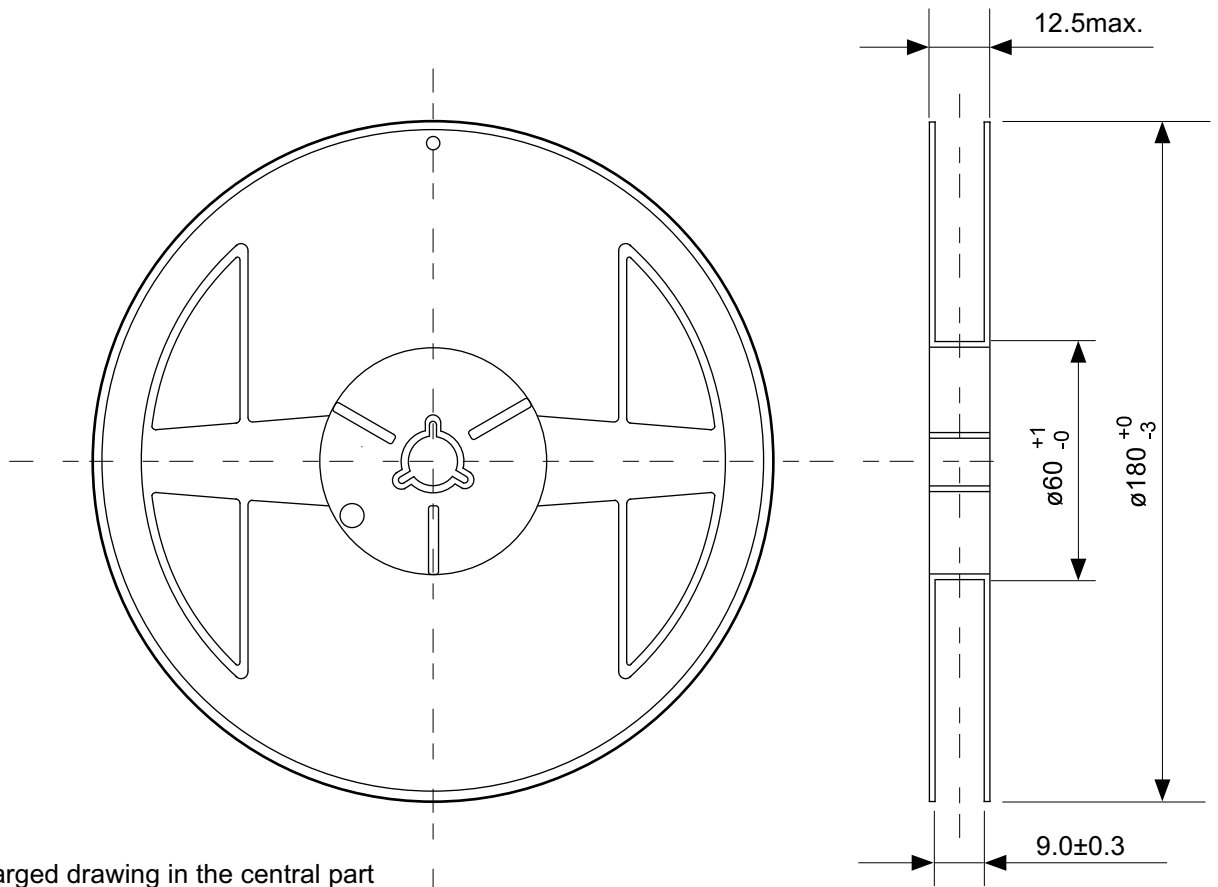

Enlarged drawing in the central part

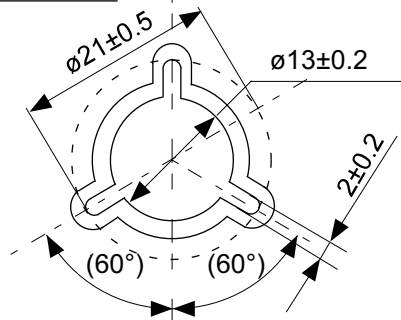

No. MP005-A-R-SD-1.1

TITLE	SOT235-A-Reel		
No.	MP005-A-R-SD-1.1		
ANGLE		QTY.	3,000
UNIT	mm		
<b>ABLIC Inc.</b>			

## Disclaimers (Handling Precautions)

1. All the information described herein (product data, specifications, figures, tables, programs, algorithms and application circuit examples, etc.) is current as of publishing date of this document and is subject to change without notice.
2. The circuit examples and the usages described herein are for reference only, and do not guarantee the success of any specific mass-production design.  
ABLIC Inc. is not responsible for damages caused by the reasons other than the products described herein (hereinafter "the products") or infringement of third-party intellectual property right and any other right due to the use of the information described herein.
3. ABLIC Inc. is not responsible for damages caused by the incorrect information described herein.
4. Be careful to use the products within their specified ranges. Pay special attention to the absolute maximum ratings, operation voltage range and electrical characteristics, etc.  
ABLIC Inc. is not responsible for damages caused by failures and / or accidents, etc. that occur due to the use of the products outside their specified ranges.
5. When using the products, confirm their applications, and the laws and regulations of the region or country where they are used and verify suitability, safety and other factors for the intended use.
6. When exporting the products, comply with the Foreign Exchange and Foreign Trade Act and all other export-related laws, and follow the required procedures.
7. The products must not be used or provided (exported) for the purposes of the development of weapons of mass destruction or military use. ABLIC Inc. is not responsible for any provision (export) to those whose purpose is to develop, manufacture, use or store nuclear, biological or chemical weapons, missiles, or other military use.
8. The products are not designed to be used as part of any device or equipment that may affect the human body, human life, or assets (such as medical equipment, disaster prevention systems, security systems, combustion control systems, infrastructure control systems, vehicle equipment, traffic systems, in-vehicle equipment, aviation equipment, aerospace equipment, and nuclear-related equipment), excluding when specified for in-vehicle use or other uses. Do not apply the products to the above listed devices and equipments without prior written permission by ABLIC Inc. Especially, the products cannot be used for life support devices, devices implanted in the human body and devices that directly affect human life, etc.  
Prior consultation with our sales office is required when considering the above uses.  
ABLIC Inc. is not responsible for damages caused by unauthorized or unspecified use of our products.
9. Semiconductor products may fail or malfunction with some probability.  
The user of the products should therefore take responsibility to give thorough consideration to safety design including redundancy, fire spread prevention measures, and malfunction prevention to prevent accidents causing injury or death, fires and social damage, etc. that may ensue from the products' failure or malfunction.  
The entire system must be sufficiently evaluated and applied on customer's own responsibility.
10. The products are not designed to be radiation-proof. The necessary radiation measures should be taken in the product design by the customer depending on the intended use.
11. The products do not affect human health under normal use. However, they contain chemical substances and heavy metals and should therefore not be put in the mouth. The fracture surfaces of wafers and chips may be sharp. Be careful when handling these with the bare hands to prevent injuries, etc.
12. When disposing of the products, comply with the laws and ordinances of the country or region where they are used.
13. The information described herein contains copyright information and know-how of ABLIC Inc.  
The information described herein does not convey any license under any intellectual property rights or any other rights belonging to ABLIC Inc. or a third party. Reproduction or copying of the information from this document or any part of this document described herein for the purpose of disclosing it to a third-party without the express permission of ABLIC Inc. is strictly prohibited.
14. For more details on the information described herein, contact our sales office.

2.2-2018.06