

## 32-bit Single Chip Microcontroller

- High-speed 32-bit RISC Core
- Multiply Accumulation
- 8K-byte RAM Built-in
- 10-bit ADC
- 4-ch. SIO, 2-ch. I<sup>2</sup>C
- High-speed DMA, Intelligent DMA

### ■ DESCRIPTIONS

The S1C33T01 is a CMOS 32-bit microcomputer composed of a CMOS 32-bit RISC core, 8K-byte RAM, DMA, 4-ch. SIO, 2-ch. I2C, ADC, timers, PLL and oscillators. The S1C33T01 features high-speed operation and low current consumption. The S1C33T01 also provides a DSP function using the internal MAC (multiplication and accumulation) operation function with the A/D converter, this makes it possible to achieve speech recognition and voice synthesis systems.

### ■ FEATURES

- CMOS LSI 32-bit parallel processing S1C33000 RISC core
- Main clock 60MHz (Max., up to 15MHz external clock input)
- Sub clock 32.768kHz (Typ., crystal)
- Instruction set 16-bit fixed length, 105 instructions  
(MAC instruction is included, 2 cycles)
- Internal RAM size 8,192 bytes
- Clock timer 1 channel
- Programmable timer 8 bits × 6 channels and 16 bits × 10 channels
- PWM timer Realized with a 16-bit programmable timer
- Watchdog timer Realized with a 16-bit programmable timer
- Serial interface 4 channels  
Clock synchronization type and asynchronization type are selectable.  
Usable as an infrared ray (IrDA) interface.
- I<sup>2</sup>C bus Single master type, 2 channels (option)
- 10-bit A/D converter Successive approximation type, 8 input channels
- High-speed DMA 4 channels
- Intelligent DMA 128 channels
- I/O port Input port : 13 bits  
I/O port : 69 bits
- Interrupt controller External interrupts : 18 types  
Internal interrupts: 69 types
- External bus interface 24-bit address bus, 16-bit data bus, 7 chip enable pins  
DRAM and burst ROM may be connected directly.
- Shipping form QFP21-176pin
- Supply voltage Core voltage : 1.8 to 3.6V  
I/O voltage : 1.8 to 5.5V
- Current consumption SLEEP state : 10μA (3.3V, 32.768kHz, clock timer run state, Typ.)  
: 2.5μA (2.0V, 32.768kHz, clock timer run state, Typ.)  
RUN state : 65mA (3.3V, 50MHz Typ.)

# S1C33T01

## ■ Block Diagram

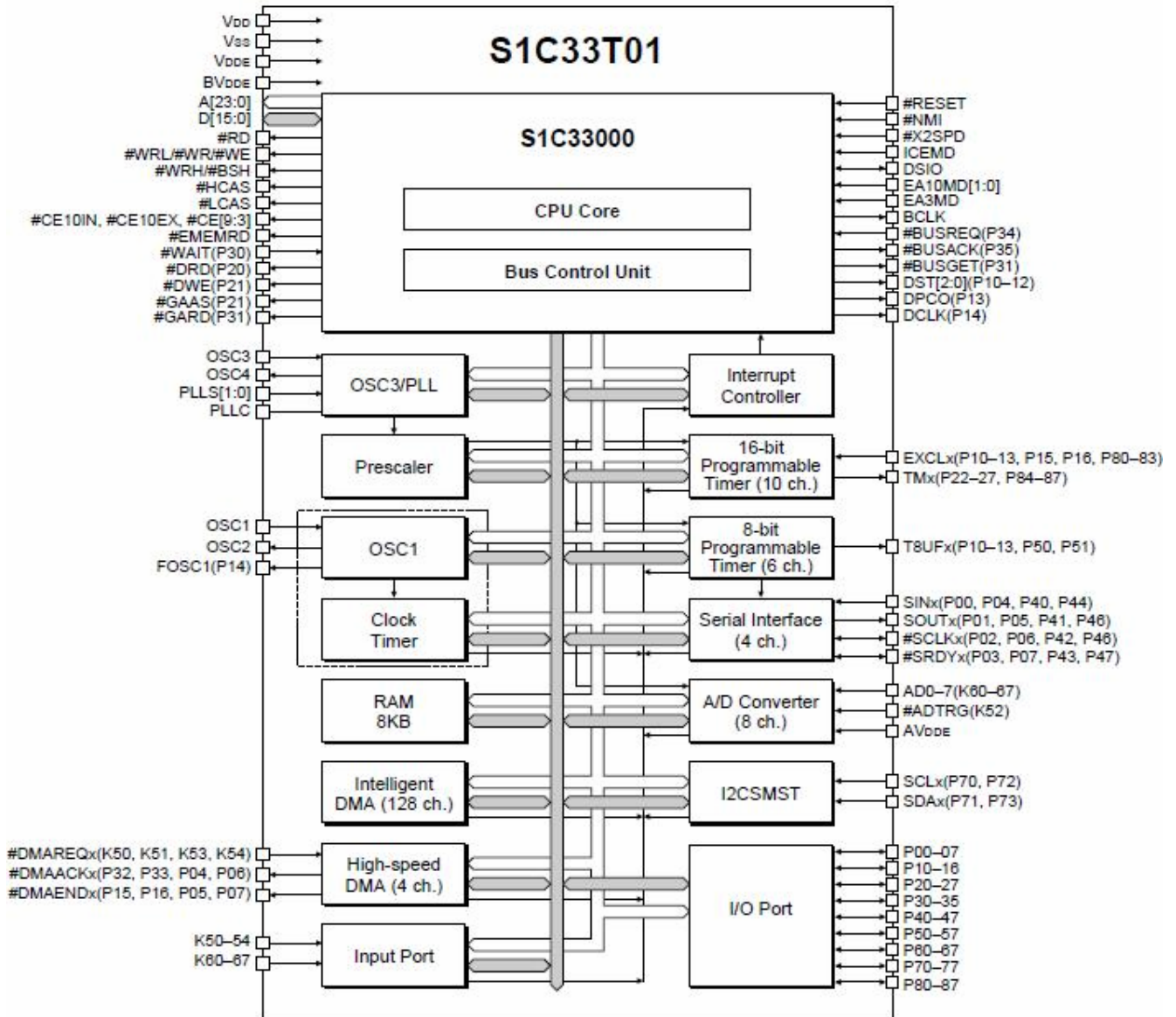

### NOTICE:

No part of this material may be reproduced or duplicated in any form or by any means without the written permission of Seiko Epson. Seiko Epson reserves the right to make changes to this material without notice. Seiko Epson does not assume any liability of any kind arising out of any inaccuracies contained in this material or due to its application or use in any product or circuit and, further, there is no representation that this material is applicable to products requiring high level reliability, such as, medical products. Moreover, no license to any intellectual property rights is granted by implication or otherwise, and there is no representation or warranty that anything made in accordance with this material will be free from any patent or copyright infringement of a third party. This material or portions thereof may contain technology or the subject relating to strategic products under the control of the Foreign Exchange and Foreign Trade Law of Japan and may require an export license from the Ministry of Economy, Trade and Industry or other approval from another government agency.

All brands or product names mentioned herein are trademarks and/or registered trademarks of their respective companies.

©Seiko Epson Corporation 2009, All rights reserved.

## SEIKO EPSON CORPORATION

SEMICONDUCTOR OPERATIONS DIVISION

### IC Sales Department

### IC International Sales Group

421-8 Hino, Hino-shi, Tokyo 191-8501, JAPAN  
Phone: +81-42-587-5814 FAX: +81-42-587-5117

### ■ Epson semiconductor website

[http://www.epson.jp/device/semicon\\_e/](http://www.epson.jp/device/semicon_e/)

Document code: 411876200

First issue Dec, 2009