

8-bit Single Chip Microcomputer

- Original Architecture Core CPU
- Low Current Consumption
- Wide-range Operating Voltage (1.8V to 5.5V)
- Built-in Melody Generator and A/D Converter

■ DESCRIPTION

The S1C88349 microcomputer features the S1C88 (Model 3) CMOS 8-bit core CPU along with 48K bytes of ROM, 2K bytes of RAM, three different timers, a serial interface with optional asynchronization or clock synchronization, and an A/D converter.

The S1C88349 is fully operable over a wide range of voltages, and can perform high speed operations even at low voltage. Like all the equipment in the S1C Family, these microcomputers have low power consumption.

A 19-bit external address bus and 4 bits chip enable signals make it possible for this microcomputer to control up to 512K × 4 bytes of memory, making them ideal for high performance data bank systems.

■ FEATURES

Core CPU	S1C88 (MODEL3) CMOS 8-bit core CPU
OSC1 oscillation circuit	Crystal oscillation circuit/CR oscillation circuit/external clock input 32.768 kHz (Typ.)
OSC3 oscillation circuit	Crystal oscillation circuit/ceramic oscillation circuit/CR oscillation circuit/external clock input 8.2 MHz (Max.)
Instruction set	608 types (usable for multiplication and division instructions)
Min. instruction execution time	0.244 μsec/8.2 MHz (2 clock)
Internal ROM capacity	48K bytes
Internal RAM capacity	2K bytes/RAM 3,216 bits/display memory
Bus line	Address bus: 19 bits (also usable as a general output port when not used as a bus) Data bus: 8 bits (also usable as a general I/O port when not used as a bus) CE signal: 4 bits WR signal: 1 bit RD signal: 1bit (also usable as a general output port when not used as a bus)
Input port	10 bits (2 bits can be set for event counter external clock input and bus request signal input terminal)
Output port	9 bits (6 bits can be set for buzzer output, LCD control, FOUT, TOUT and bus acknowledge signal output terminal)
I/O port	8 bits (4 bits each can be set for serial interface input/output and analog comparator/AD input)
Serial interface	1ch (optional clock synchronous system or asynchronous system)
Timer	Programmable timer (8 bits): 2ch (1ch can be set as an event counter or 2ch as a 16 bits programmable timer for 1ch) Clock timer (8 bits): 1ch Stopwatch timer (8 bits): 1ch
LCD driver	Dot matrix type (supports 5 × 8 or 5 × 5 fonts) 51 segments × 32 commons (1/5 bias) 67 segments × 16 or 8 commons (1/5 bias) Built-in LCD power supply circuit (booster type, 5 potentials)
Sound generator	Envelope function, equipped with volume control
Watchdog timer	Built-in
Analog comparator	2ch built-in (not available if A/D converter is used)
A/D converter	Resolution: 10 bits, input: 4ch, Maximum error: ±5 LSB (not available if analog comparator is used)
Supply voltage detection (SVD) circuit	Can detect up to 16 different voltage levels
Interrupt	External interrupt: Input interrupt 2 systems (3 types) Internal interrupt: Timer interrupt 3 systems (9 types) Serial interface interrupt 1 system (3 types) A/D converter interrupt 1 system (1 type)
Supply voltage	Normal mode: 2.4 V–5.5 V (Max. 4.2 MHz) $V_{D1} = 2.2 V$ Low power mode: 1.8 V–3.5 V (Max. 80 kHz) $V_{D1} = 1.2V$ High speed mode: 3.5 V–5.5 V (Max. 8.2 MHz) $V_{D1} = 3.3V$
Current consumption	SLEEP mode: 0.3 μA

S1C88349

	HALT mode: 1.5 μ A (Typ./normal mode) Run (32 kHz): 9 μ A (Typ./normal mode) Run (4 MHz): 1.1 mA (Typ./normal mode)
Supply form	QFP18-176pin, QFP21-176pin or chip

* The number of bits cited for output ports and I/O ports does not include those shared with the bus.

■ BLOCK DIAGRAM

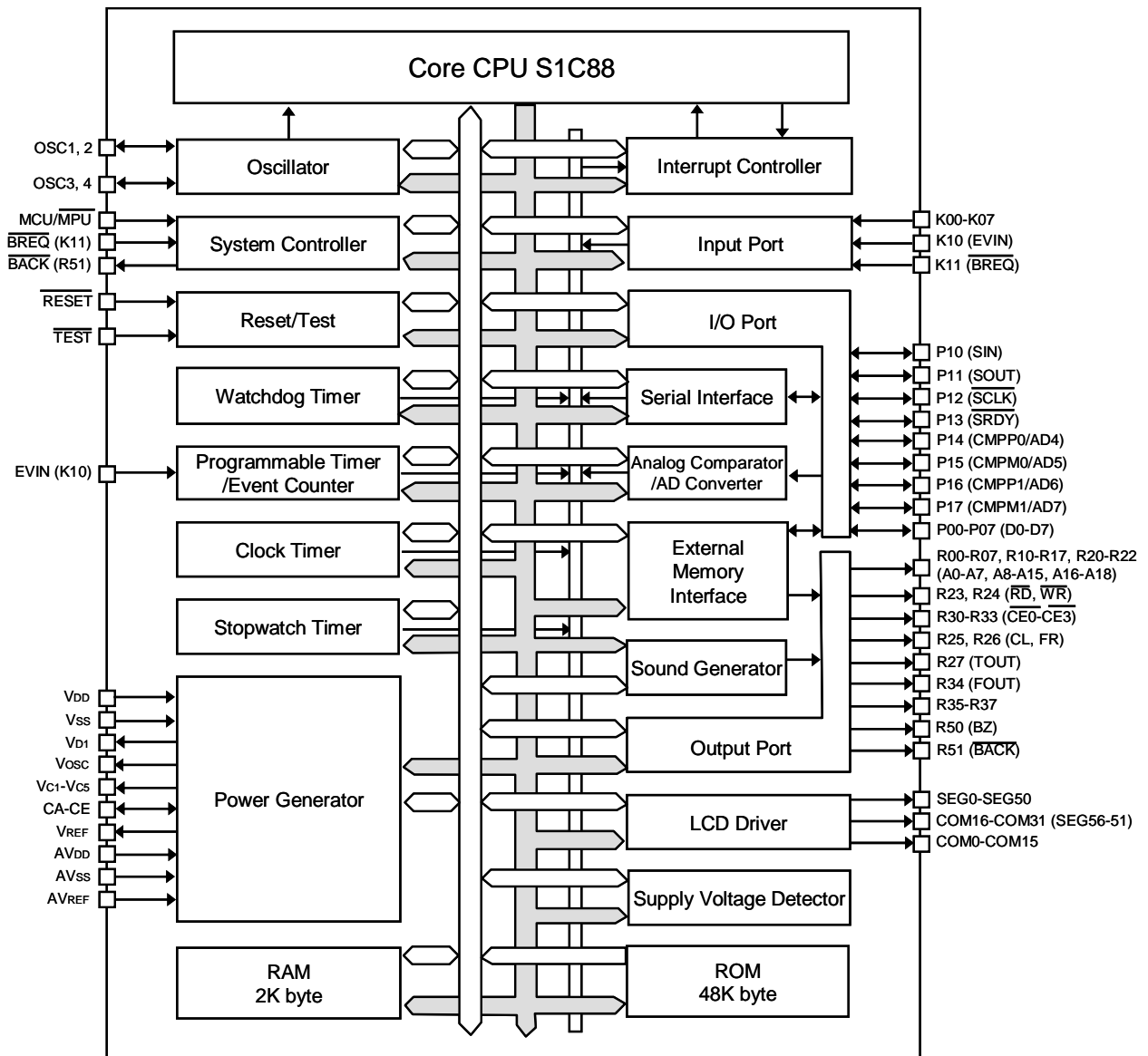

NOTICE:

No part of this material may be reproduced or duplicated in any form or by any means without the written permission of Seiko Epson. Seiko Epson reserves the right to make changes to this material without notice. Seiko Epson does not assume any liability of any kind arising out of any inaccuracies contained in this material or due to its application or use in any product or circuit and, further, there is no representation that this material is applicable to products requiring high level reliability, such as, medical products. Moreover, no license to any intellectual property rights is granted by implication or otherwise, and there is no representation or warranty that anything made in accordance with this material will be free from any patent or copyright infringement of a third party. This material or portions thereof may contain technology or the subject relating to strategic products under the control of the Foreign Exchange and Foreign Trade Law of Japan and may require an export license from the Ministry of Economy, Trade and Industry or other approval from another government agency.

All brands or product names mentioned herein are trademarks and/or registered trademarks of their respective companies.

©Seiko Epson Corporation 2012, All rights reserved

SEIKO EPSON CORPORATION

MICRODEVICES OPERATIONS DIVISION

Device Sales & Marketing Department
421-8 Hino, Hino-shi, Tokyo 191-8501, JAPAN
Phone: +81-42-587-5814 FAX: +81-42-587-5117

EPSON semiconductor website

http://www.epson.jp/device/semicon_e/

Document code: 412300800
First issue Feb, 2012 in Japan