

## FM RADIO IC FOR DIGITAL TUNING SYSTEM

### DESCRIPTION

The SA1140 is an IF system IC designed for FM car stereo receivers. It features versatile muting characteristics which can be varied with external parts.

### FEATURES

- \* Muting characteristics
  - a) Muting operation is performed under weak signal strength.
  - b) Maximum muting attenuation can be selected to be approximately 6 to 40 dB.
  - c) Input signal strength level which actuates the muting circuit can be set freely.
- \* High limiting sensitivity
- \* High S/N (78 dB typ.)
- \* Good AMR
- \* Signal meter drive output proportional to the input signal strength in dB (suitable to control multiplex IC SA3370).

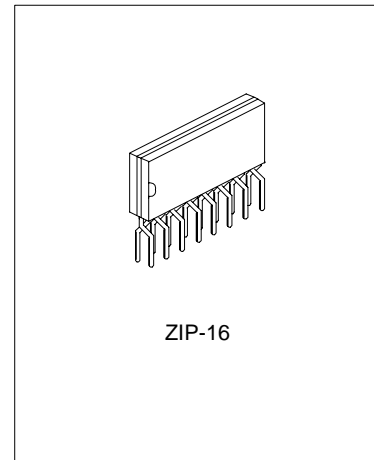

### ORDERING INFORMATION

Device	Package
SA1140	ZIP-16

### APPLICATIONS

- \* FM car stereo receivers, FM home radio

### BLOCK DIAGRAM

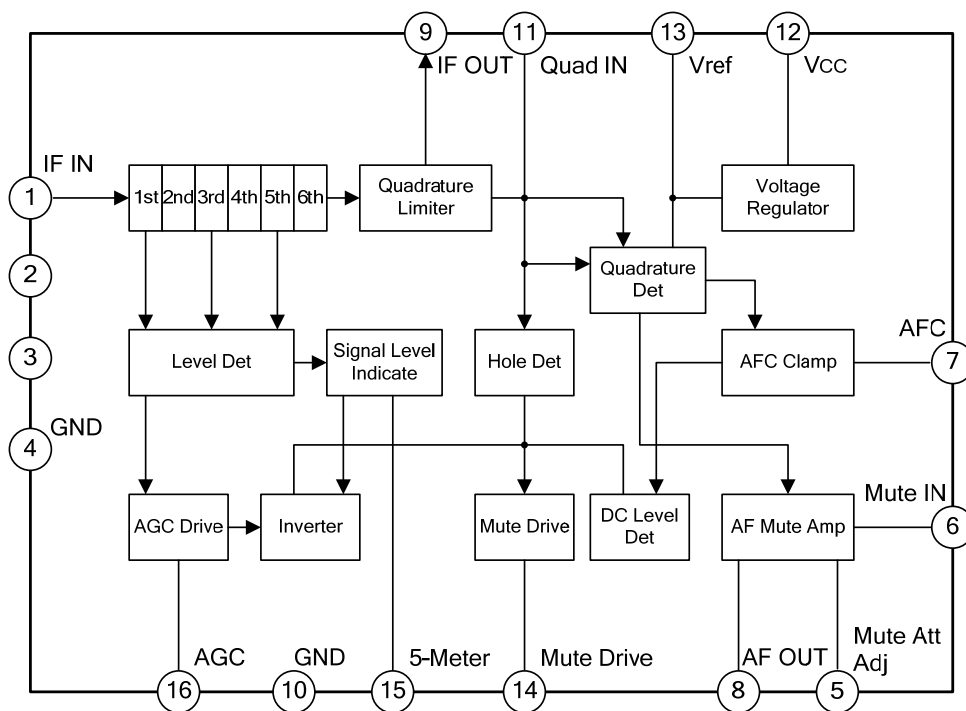

**ABSOLUTE MAXIMUM RATING** (T<sub>amb</sub>=25°C)

Characteristics	Symbol	Rating	Unit
Maximum Supply Voltage	VCC max	16	V
Maximum Supply Current	ICC max	40	mA
Allowable Power Dissipation	Pd max	640	mW
		460	mW
Input Voltage	VIN	±1	Vp-p
Flow-In Current	I2	±0.2	mA
	I3	±0.2	mA
	I6	2	mA
Flow-Out Current	I5	1	mA
	I13	2	mA
	I14	2	mA
	I15	1	mA
	I16	1	mA
Operating Temperature	Topr	-20 to +70	°C
Storage Temperature	Tstg	-40 to +125	°C

**ELECTRICAL CHARACTERISTICS** (T<sub>amb</sub>=25°C, VCC=8V, f=10.7MHz, see specified test circuit)

Characteristics	Symbol	Test condition	Min.	Typ.	Max.	Unit
Recommended Supply Voltage	VCC			8		V
Operating Supply Voltage Range	VCCop		7.5		16	V
Quiescent Current	ICCO	VIN=0	15	21	27	mA
Current Drain	ICC	VIN = 100 dBμ	20	25	30	mA
Demodulation Output	VO	VIN = 100 dBμ, 400 Hz 100% mod.	200	260	320	mVrms
Total Harmonic Distortion	THD	VIN = 100 dBμ, 400 Hz 100% mod.		0.05	0.2	%
Signal-To-Noise Ratio	S/N	VIN = 100 dBμ, 400 Hz 100% mod.	72	78		dB
Input Limiting Voltage	VIN (lim)	VO: 3 dB down, 400 Hz 100% mod.		25	29	dBμ
Muting Sensitivity	VIN (Mute)	V14 = 2.0 V	22	26	32	dBμ
Muting Attenuation (1)	Mute (ACC)	V6 = 2.0 V (22 kΩ), VIN = 100 dBμ, 400 Hz 100% mod.	10	15	20	dB
Muting Attenuation (2)	Mute (ACC)	V6 = 5.0 V (22 kΩ), VIN = 100 dBμ, 400 Hz 100% mod.	24	28	32	dB
Muting Bandwidth	BW (Mute)	VIN = 100 dBμ, V14 = 2.0 V	140	210	370	kHz

(To be continued)

(Continued)

Characteristics	Symbol	Test condition	Min.	Typ.	Max.	Unit
AM Rejection Ratio	AMR	V <sub>IN</sub> = 100 dB $\mu$ , FM 400 Hz. 100% mod., AM 1 kHz 30% mod.	50	63		dB
Muting Drive Output(1)	V14-0	V <sub>IN</sub> =0	3.5	4.2	5.0	V
Muting Drive Output (2)	V14-100	V <sub>IN</sub> = 100 dB $\mu$	0	0	0.3	V
Signal Meter Output (1)	V15-0	V <sub>IN</sub> =0	0	0.1	0.3	V
Signal Meter Output (2)	V15-50	V <sub>IN</sub> = 50 dB $\mu$	0.8	1.4	2.0	V
Signal Meter Output (3)	V15-70	V <sub>IN</sub> = 70 dB $\mu$	1.6	2.4	3.2	V
Signal Meter Output (4)	V15-100	V <sub>IN</sub> = 100 dB $\mu$	4.5	5.3	6.0	V
AGC Output (1)	V16-0	V <sub>IN</sub> =0	3.5	4.1	4.5	V
AGC Output (2)	V16-100	V <sub>IN</sub> = 100 dB $\mu$	0	0.02	0.3	V
Offset Voltage (1)	V7-13	V <sub>IN</sub> =0, pin 7 to 13	-0.25	0	+0.25	V
Offset Voltage (2)	V8-13	V <sub>IN</sub> =0, pin 8 to 13	-0.5	0	+0.5	V

## PIN CONFIGURATIONS

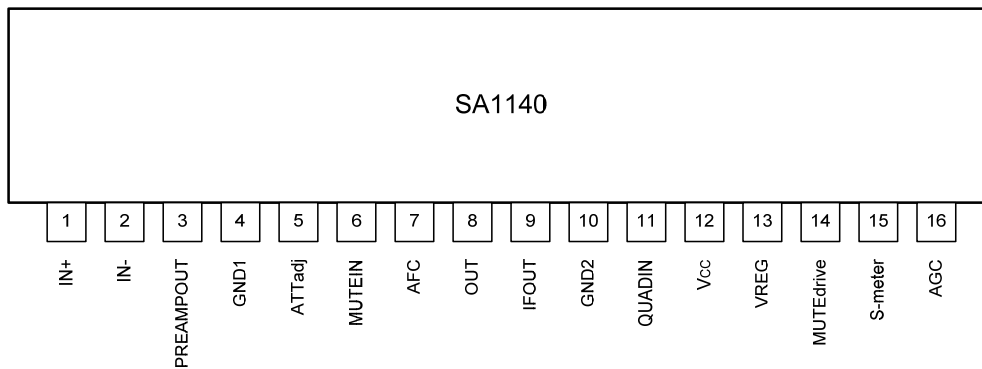

## PIN DESCRIPTIONS

Pin No.	Pin Name	Description
1	IN+	Positive in
2	IN-	Negative in
3	PREAMPOUT	Out of IF preamp
4	GND1	Gnd1
5	ATTadj	Resister connected between p5 and GND determines the maximum muting attenuation
6	MUTEIN	The higher the current flowing into p6,the lower the gain (the higher the attenuation )
7	AFC	AFC clamp
8	OUT	Out of AF

(To be continued)

(Continued)

Pin No.	Pin Name	Description
9	IFOUT	Out of IF
10	GND2	Gnd2
11	QUADIN	In of quadrature det
12	VCC	Vcc
13	VREG	Regulative voltage
14	MUTEdrive	Connected to p6 through resistor
15	S-meter	Signal meter
16	AGC	Automatic gain control

## FUNCTION DESCRIPTION

### 1. Muting Characteristic

The muting operation is performed by an AF preamplifier, the gain of which varies continuously with control current, and a muting drive output circuit which supplies the control current.

The gain of the AF preamplifier decreases with increasing gain control current applied to pin 6. However, the gain does not decrease further when the control current reaches approximately 120  $\mu$ A or greater. The lower limit of the gain under this condition depends upon a resistor connected between pin 5 and GND, and the higher the resistance the lower the gain (the higher the attenuation). Thus the maximum muting attenuation will be set by connecting the resistor between pin 5 and GND.

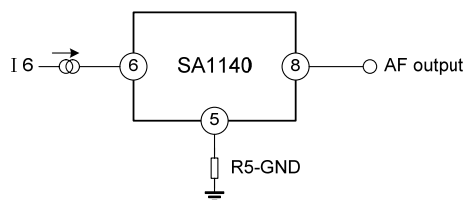

### 2. The muting drive output comes in three types:

- 1) Hole detector output which develops a voltage when C/N (carrier-to-noise ratio) lowers under weak signal input conditions.
- 2) A reversed output of the signal strength indicating output (output at pin 15)
- 3) A bandwidth limited muting drive output which develops a voltage when the AFC output becomes higher than  $\pm V_{BE}$  during tuning-off operation.

All these outputs are led to an OR circuit and the processed output is developed at pin 14.

3. The general method to adjust the muting circuit of the SA1140 is: to set the signal input level required to actuate the muting circuit with the R16-G, to adjust the slope of the curve for the muting attenuation vs. antenna signal input with the R15-G, and to adjust the maximum muting attenuation (determined by setting the noise level at no signal) with the R5-G. The slope of the curve for the muting attenuation vs. antenna signal input level can also be adjusted by the resistor connected between pins 14 and 6 in addition to R15-G, however, selecting a resistor too high does not allow the muting control current flowing into pin 6 to reach 120  $\mu$ A even though the maximum muting drive output (V14) is applied, namely the muting attenuation does not reach its maximum value. Accordingly a recommended value of the resistor between pins 14 and 6 is about 22 k $\Omega$ .



PACKAGE OUTLINE

