

Features

- Saifun NROM™ Flash Cell
- Serial Peripheral Interface (SPI) Compatible, Supports SPI Modes 0 (0,0) and 3 (1,1)
- Page Program Operation:
 - 1024 pages (256 Bytes/Page)
 - Single Page Rewrite Cycle (Erase and Program) in 10ms Typical
- Page Program Mode (up to 256 bytes) in 8ms Typical
- Page Erase (256 bytes) in 3 ms
- Sector Erase (512 Kb) in 0.5 s
- Bulk Erase (2 Mb)
- Single Supply Voltage: 2.7 V to 3.6 V
- 25MHz Clock Rate
- Block Write Protection: Protect Quarter, Half or Entire Array
- Write Protect Pin and Write Disable Instructions of Both Hardware and Software Data Protection
- 100,000 Erase Cycles (Minimum)
- More than 20-Year Data Retention
- Low-power Standby Current (less than 1μA)
- 8-SOIC Narrow Package
- MLF Leadless Package
- Temperature Range:
 - Industrial: -40°C to +85°C
 - Commercial: 0°C to +70°C

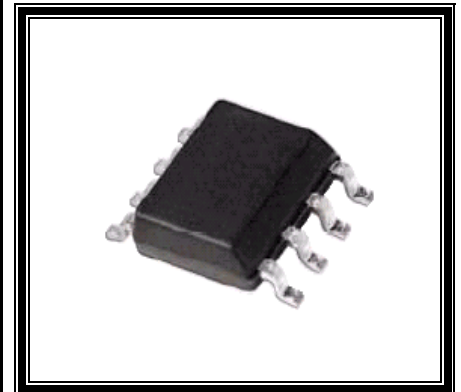

SA25F020 Advanced Information

2Mb Serial Flash with 25MHz SPI Bus Interface



<http://www.saifun.com>

Saifun NROM™ is a trademark of Saifun Semiconductors Ltd.

General Description

The SA25F020 is a 2Mb (512K X 4) CMOS non-volatile serial Flash Memory. This device fully conforms to the SPI 4-wire protocol, is enabled through the Chip Select (CSb) pin, and uses Clock (SCK), Data-in (SI) and Data-out (SO) pins to synchronously control data transfer between the SPI microcontroller and the Serial FLASH memory.

The memory can be programmed from 1 up to 256 bytes at a time via the Page Program (PP) instruction.

The memory is organized into four sectors. Each sector contains 256 pages, with each page being 256 bytes wide. The entire memory can therefore be viewed as consisting of 1024 pages, or 262,144 bytes.

The memory can be erased in one of the following ways:

- 256 bytes at a time, using the Page Erase (PE) instruction
- 512 Kb at a time, using the Sector Erase (SE) instruction
- 2 Mb at a time, using the Bulk Erase (BE) instruction

Each device requires only a 3.0V power supply (2.7 V to 3.6 V) for both read and write functions. Internally generated and regulated voltages are provided for the program and erase operations. The SA25F020 does not require a V_{PP} supply.

The HOLDb pin may be used to suspend any serial communication without resetting the serial sequence. In addition, the serial interface allows a minimal-pin-count packaging designed to simplify PC board layout requirements and offers the designer a variety of low-voltage and low-power options.

The SA25F020 is available in a space-saving, 8-lead narrow SOIC package

The SA25F020 is part of the SPI Flash and EEPROM family. It is designed to work with any SPI-compatible, high-speed microcontroller, and offers both hardware (WPb pin) and Software ("block protect") data protection. For example, programming a 2-bit code into the status register prevents program with top ¼, top ½ or entire array write protection and enables block write protection. Separate program enable and program disable instructions are provided for additional data protection. Hardware data protection is provided via the WPb pin to protect against inadvertent write attempts to the status register.

Saifun's SPI Serial Flash products are designed and tested for applications requiring high endurance and low power consumption for a continuously reliable non-volatile solution for all markets.

Table of Contents

Features	1	Functional Description	17
General Description	2	Instructions	17
Memory Organization	5	Read Status Register (RDSR)	18
Connection Diagrams	6	Write Enable (WREN)	20
Ordering Information	7	Write Disable (WRDI)	20
Product Specifications	8	Write Status Register (WRSR)	21
Absolute Maximum Ratings	8	Read Data Bytes (READ)	23
ESD/Latch Up Specification (JEDEC 8 Spec)	8	Fast Read (FAST_READ)	24
Operating Conditions	8	Page Programming (PP)	25
DC Characteristics	9	Page Erase (PE)	27
AC Test Conditions	10	Sector Erase (SE)	28
Timing Diagrams	11	Bulk Erase (BE)	29
Signal Description	13	Software Protection (SP)/ Deep Powerdown (DP) .	30
Chip Select (CSb)	13	Release from Software Protect (RES)	31
Serial Clock (SCK)	13	Release from Software Protection and Read	
Serial Input (SI)	13	Electronic Signature (RES)	32
Serial Output (SO)	13	Powerup and Powerdown	33
Hold (HOLDb)	13	Physical Dimensions	34
Write Protect (WPb)	13	Contact Information	37
Serial Interface Description	14	Life Support Policy	37
SPI Modes	14		
Master	14		
Slave	14		
Transmitter/Receiver	14		
Serial Opcode	14		
Invalid Opcode	14		
Chip Select (CSb)	15		
Hold Condition	15		
Write Protect	16		

List of Figures

Figure 1. SA25F020 Block Diagram	5
Figure 2. SOIC 8 (150 mil)/PDIP/MLF Package (Top View)	6
Figure 3. SA25F020 Ordering Information	7
Figure 4. SPI Mode 0 (0,0) Input Timing	11
Figure 5. SPI Mode 0 (0,0) Output Timing	11
Figure 6. AC Measurements I/O Waveform	12
Figure 7. Supported SPI Modes	14
Figure 8. Hold Condition	15
Figure 9. SPI Serial Interface	17
Figure 10. Read Status Register (RDSR) Instruction Sequence	19
Figure 11. Write Enable (WREN) Instruction Sequence	20
Figure 12. Write Disable (WRDI) Instruction Sequence.	20
Figure 13. Write Status Register (WRSR) Instruction Sequence	22
Figure 14. Read (READ) Instruction Sequence	23
Figure 15. Fast Read (FAST_READ) Instruction Sequence	24
Figure 16. Page Programming (PP) Instruction Sequence	26
Figure 17. Page Erase (PE) Instruction Sequence	27
Figure 18. Sector Erase (SE) Instruction Sequence	28

Figure 19. Bulk Erase (BE) Instruction Sequence	29
Figure 20. Software Protection Instruction Sequence	30
Figure 21. Release from Software Protect (RES) Instruction Sequence	31
Figure 22. Release from Software Protection and Read Electronic Signature (RES) Instruction Sequence	32
Figure 23. 8-pin SOIC Package	34
Figure 24. 8-pin MLF Leadless Package	35
Figure 25. Molded Dual-in-line Package (N) Package Number N08E	36

List of Tables

Table 1. Memory Organization	5
Table 2. Pin Names	6
Table 3. DC Characteristics	9
Table 4. AC Test Conditions	10
Table 5. AC Measurements	12
Table 6. Instruction Set	17
Table 7. Status Register Format	18
Table 8. Read Status Register Definition	18
Table 9. Block Write Protect Bits	21
Table 10. WPBEN Operation	21
Table 11. Powerup	33

Memory Organization

The memory is organized in the following manner:

- 262,144 bytes (8 bits each)
- 4 sectors (512 Kb, 65,536 bytes each), as shown in Table 1
- 1024 pages (256 bytes each)

Each page can be individually programmed, with the bits programmed from 1 to 0. The SA25F020's memory can be erased via the Page, Sector or Bulk Erase commands, with the bits erased from 0 to 1.

Table 1. Memory Organization

Sector	Address Range	
3	30000h	3FFFFh
2	20000h	2FFFFh
1	10000h	1FFFFh
0	00000h	0FFFFh

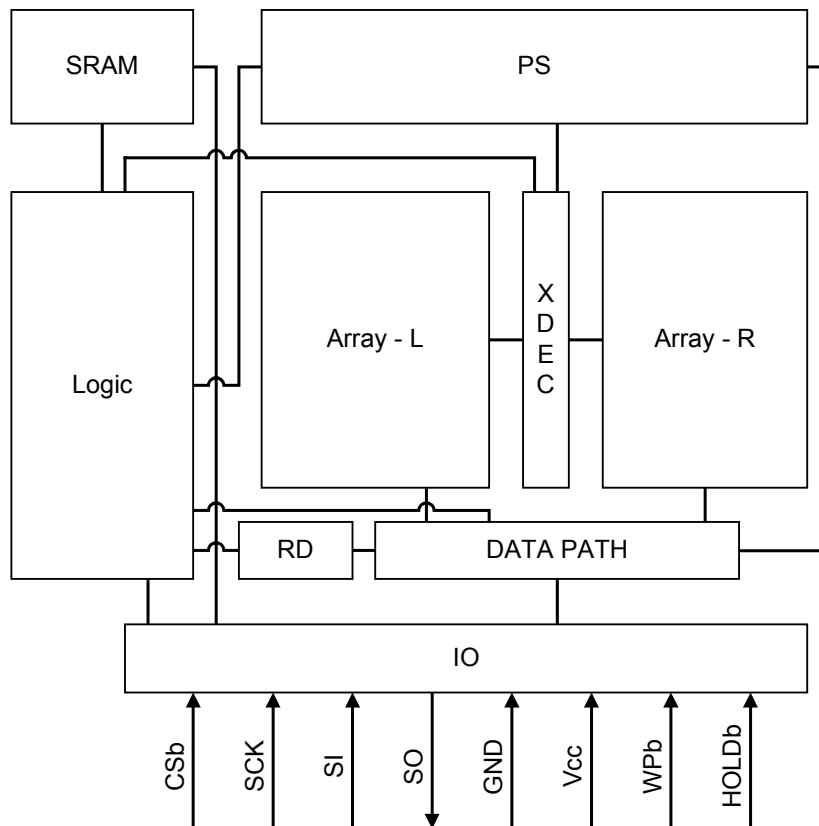

Figure 1. SA25F020 Block Diagram

Connection Diagrams

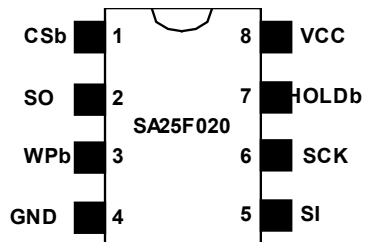

Figure 2. SOIC 8 (150 mil)/PDIP/MLF Package (Top View)

Table 2. Pin Names

Pin Name	Signal Name
CSb	Chip Select
SCK	Serial Data Clock
SI	Serial Data Input
SO	Serial Data Output
GND	Ground
V _{CC}	Power Supply
WPb	Write Protect
HOLDb	Suspend Serial Input

Ordering Information

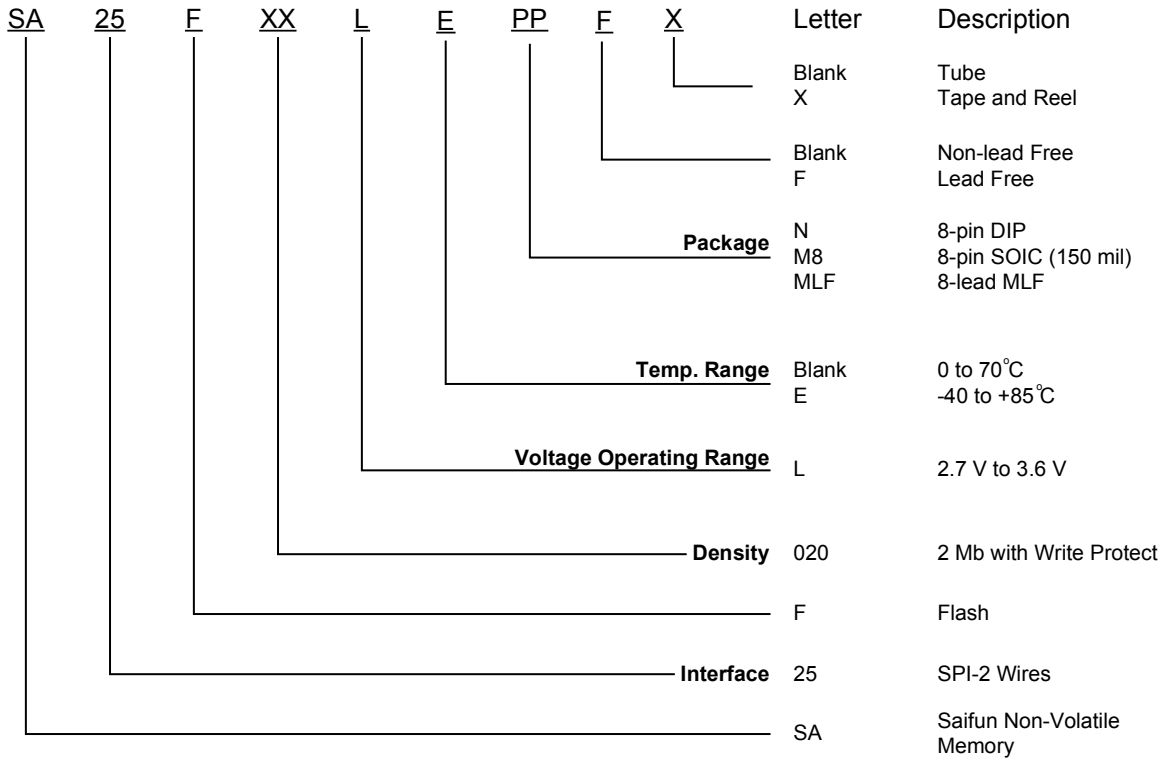

Figure 3. SA25F020 Ordering Information

Product Specifications

Absolute Maximum Ratings

Storage Temperature	-65 °C to +150 °C
All input or output voltages with respect to Ground	4.5 V to -0.3 V
Lead Temperature (Soldering, 10 seconds)	+235 °C
ESD Rating	2000 V min.

ESD/Latch Up Specification (JEDEC 8 Spec)

Human Body Model	Minimum 4 KV
Machine Model	Minimum 500 V
Charge Device Model	Minimum 1 KV
Latch Up	100 mA on all pins +125°C

Operating Conditions

Operating Temperature: SA25F020	0 °C to +70 °C
SA25F020E	-40 °C to +85 °C
Positive Power Supply: SA25F020	2.7 V to 3.6 V

DC Characteristics

Applicable over recommended operating range from $T_{AI} = -40\text{ }^{\circ}\text{C}$ to $85\text{ }^{\circ}\text{C}$, $V_{CC} = 2.7\text{-}3.6\text{ V}$.

Table 3. DC Characteristics

Symbol	Parameter	Test Conditions	Limits			Unit
			Min	Typ*	Max	
V_{CC}	Supply Voltage		2.7	3	3.6	V
I_{CC1}	Active Power Supply Current (Read)	$SCK = 0.1V_{CC}/0.9 V_{CC}$ @ 25 MHz		9	12	mA
I_{CC2}	Active Power Supply Current (Page Program)	$CSb = V_{CC}$			15	mA
I_{CC3}	Active Power Supply Current (WRSR)	$CSb = V_{CC}$			15	mA
I_{CC4}	Active Power Supply Current (SE)	$CSb = V_{CC}$			15	mA
I_{CC5}	Active Power Supply Current (BE)	$CSb = V_{CC}$			15	mA
I_{SB}	Standby Current	$V_{CC} = 3.0\text{ V}$, $CSb = V_{CC}$			1	μA
I_{IL}	Input Leakage Current	$V_{IN} = \text{GND to } V_{CC}$			1	μA
I_{OL}	Output Leakage Current	$V_{IN} = \text{GND to } V_{CC}$			1	μA
V_{IL}	Input Low Voltage		-0.3		$0.3 V_{CC}$	V
V_{IH}	Input High Voltage		$0.7 V_{CC}$		$V_{CC} + 0.5$	V
V_{OH}	Output High Voltage	$I_{OH} = -0.1\text{ mA}$	$V_{CC} - 0.2$			V
V_{OL}	Output Low Voltage	$I_{OL} = 1.6\text{ mA}$; $V_{CC} = 2.7\text{ V}$			0.4	V

*Typical values are at $T_{AI} = 25\text{ }^{\circ}\text{C}$ and 3 V.

AC Test Conditions

Table 4. AC Test Conditions

Symbol	Parameter	25 MHz			Unit
		Min	Typ	Max	
F _{SCK}	SCK Clock Frequency	D.C.		25	MHz
t _{CRT}	Clock Rise Time (Slew Rate)	0.1			V/ns
t _{CFT}	Clock Fall Time (Slew Rate)	0.1			V/ns
t _{WH}	SCK High Time	18			ns
t _{WL}	SCK Low Time	18			ns
t _{CS}	CSb High Time	100			ns
t _{CS} **	CSb Setup Time	10			ns
t _{CSH} **	CSb HOLD Time	10			ns
t _{HD} **	HOLD _b Setup Time	10			ns
t _{CD} **	HOLD _b Hold Time	10			ns
t _v	Output Valid	0		15	ns
t _{HO}	Output Hold Time	0			ns
t _{HD:DAT}	Data in Hold Time	5			ns
t _{SU:DAT}	Data in Setup Time	5			ns
t _{LZ} **	HOLD _b to Output Low Z			15	ns
t _{HZ} **	HOLD _b to Output High Z			20	ns
t _{DIS} **	Output Disable Time			15	ns
t _{WPS} **	Write Protect Setup Time	20			ns
t _{WPH} **	Write Protect Hold Time	100			ns
t _{PP} *	256-byte Page Programming		8	10	ms
t _{EP} *	Page Erase and Programming		10	15	ms
t _{PE}	Page Erase Time		3	6	ms
t _{SE}	Sector Erase Time		0.5	0.8	sec
t _{BE}	Bulk Erase Time		2	3	sec
t _{RES}	Release SP Mode			1000	ns
Endurance		100K			Erase cycles

* 256 bytes in the checkerboard programming formation.

** Value guaranteed by characterization, not 100% tested in production

Timing Diagrams

All timing diagrams are based on SPI protocol modes 0 and 1.

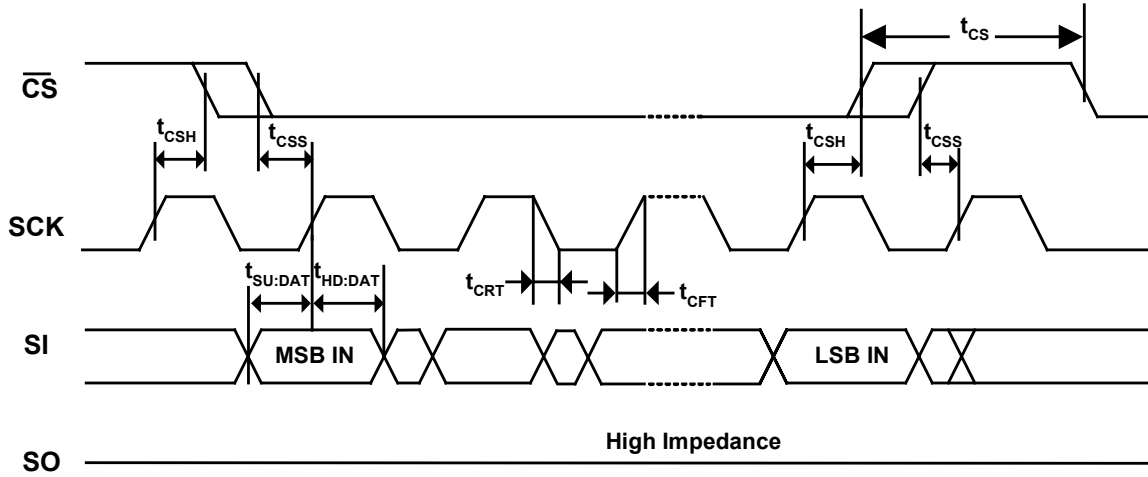

Figure 4. SPI Mode 0 (0,0) Input Timing

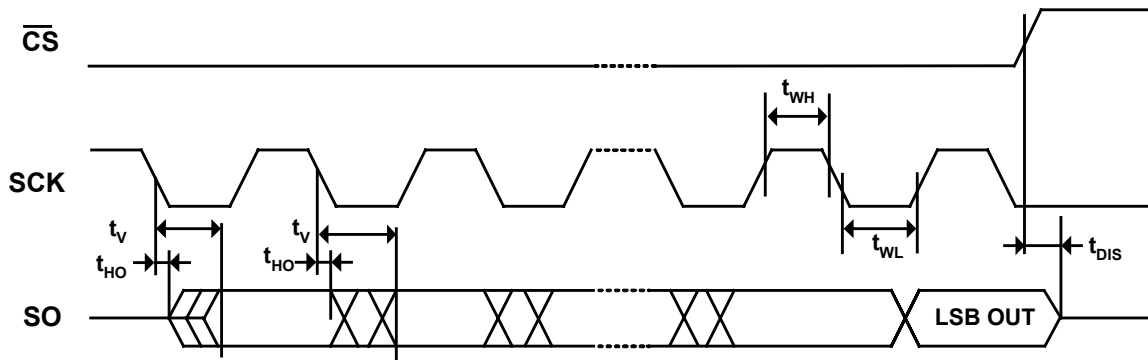
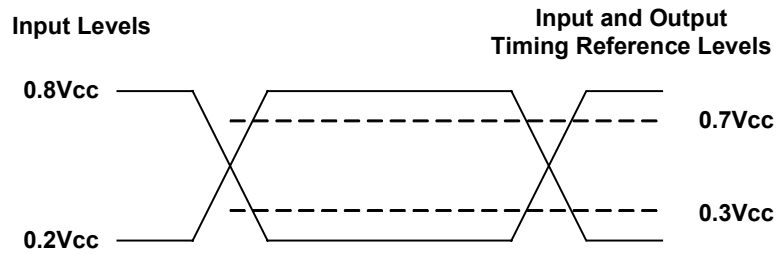

Figure 5. SPI Mode 0 (0,0) Output Timing

**Figure 6. AC Measurements I/O Waveform****Table 5. AC Measurements**

Symbol	Parameter	Min	Max	Unit
C_L	Load Capacitance	30		pF
	Input Rise and Fall Times		5	ns
	Input Pulse Voltage	$0.2 V_{CC}$ to $0.8 V_{CC}$		V
	Input and Output Timing Reference Voltages	$0.3 V_{CC}$ to $0.7 V_{CC}$		V

Signal Description

Chip Select (CSb)

This is an active-low input pin to the device that is generated by the master controlling the device. A low level on this pin selects the device, while a high level deselects the device. All serial communications with the device are enabled only when this pin is held low.

Serial Clock (SCK)

This is an input pin to the device that is generated by the master controlling the device. It is a clock signal that synchronizes the communication between a master and the device. All input information (SI) to the device is latched on the rising edge of this clock input, while output data (SO) from the device is driven after the falling edge of this clock input.

Serial Input (SI)

This is an input pin to the device that is generated by the master controlling the device. The master transfers input information (instruction, addresses and the data to be programmed) into the device serially via this pin. This input information is latched on the rising edge of the SCK.

Serial Output (SO)

This is an output pin from the device that is used to transfer output data to the controlling master. Output data is serially shifted out on this pin after the falling edge of the SCK.

Hold (HOLDb)

This is an active low input pin to the device that is generated by the master controlling the device. When driven low, this pin suspends any current communication with the device. The suspended communication can be resumed by driving this pin high. This feature eliminates the need to re-transmit the entire sequence by enabling the master to resume the communication from where it was left off. This pin should be tied high if this feature is not used. Refer to *Hold Condition*, page 15, for additional details.

Write Protect (WPb)

This is an active low input pin to the device. This pin allows enabling and disabling of writes to the device's memory array and status register. When this pin is held low, writes to the memory array and status register are disabled; when it is held high, they are enabled. Refer to *Write Protect*, page 16, for additional details.

Serial Interface Description

SPI Modes

These devices can be driven by a microcontroller with its SPI peripheral running in either of the two following modes:

- CPOL=0, CPHA=0
- CPOL=1, CPHA=1

In both of these modes, input data is latched on the rising edge of SCK, and output data is available from the falling edge of SCK. The difference between the two modes, as shown in Figure 7, is the clock polarity when the bus master is in Standby mode and is not transferring data, as follows:

- SCK remains at 0 for CPOL = 0, CPHA = 0
- SCK remains at 1 for CPOL = 1, CPHA = 1

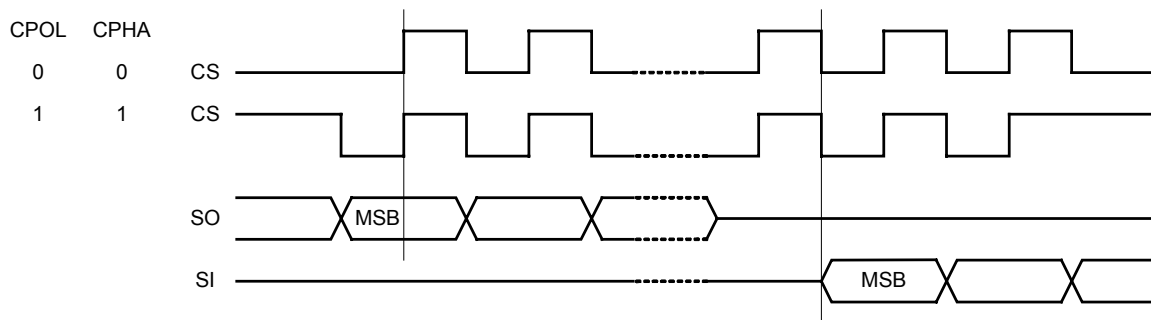

Figure 7. Supported SPI Modes

Master

The device that generates the SCK.

Slave

As the SCK pin is always an input, the SA25F020 always operates as a slave.

Transmitter/Receiver

The SA25F020 has separate pins designated for data transmission and reception.

Serial Opcode

The first byte is received after the device is selected. This byte contains the opcode that defines the operation to be performed (for more details, refer to Table 6, page 17).

Invalid Opcode

If an invalid opcode is received, no data is shifted into the SA25F020, and the serial output pin remains in a high impedance state until a CSb falling edge is detected again, which reinitializes the serial communication.

Chip Select (CSb)

The SA25F020 is selected when the CSb pin is low. When the device is not selected, data is not accepted via the SI pin, and the SO pin remains in a high impedance state.

Hold Condition

The HOLDb pin is used in conjunction with the CSb pin to select the SA25F020. When the device is selected and a serial sequence is underway, HOLDb can be used to pause the serial communication with the master device without resetting the serial sequence.

To enter the hold condition the device must be selected, with CSb low.

As shown in Figure 8, the Hold condition starts on the falling edge of the HOLDb signal, provided that SCK is low. The Hold condition ends on the rising edge of the HOLDb signal, provided that SCK is low. If the falling edge does not coincide with SCK being low, the Hold condition starts only after SCK next goes low. Similarly, if the rising edge does not coincide with SCK being low, the Hold condition ends only after SCK next goes low.

During the Hold condition, SO is high impedance, and SI and SCK are Don't Care. In most cases, the device is kept selected, with CSb driven low, for the entire duration of the Hold condition, which ensures that the internal logic state remains unchanged from the moment it enters the Hold condition.

NOTE:

Driving CSb high while HOLDb is still low is not a legal operation.

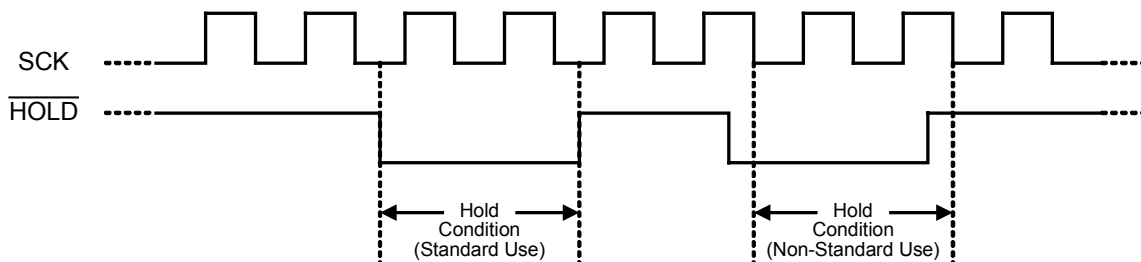

Figure 8. Hold Condition

Write Protect

The WPb pin enables write operations to the status register when held high. When the WPb pin is brought low and the WPBEN bit is 1, all write operations to the status register are inhibited (for more details, refer to Table 10, page 21). If WPb goes low while CSb is still low, the write to the status register is interrupted. If the internal write cycle has already been initiated, WPb going low has no effect on any write operations to the status register. The WPb pin function is blocked when the WPBEN bit in the status register is 0, which enables the user to install the SA25F020 in a system with the WPb pin tied to ground but still able to write to the status register. All WPb pin functions are enabled when the WPBEN bit is set to 1.

Functional Description

Instructions

Figure 9 presents a schematic diagram of the SA25F020's SPI serial interface.

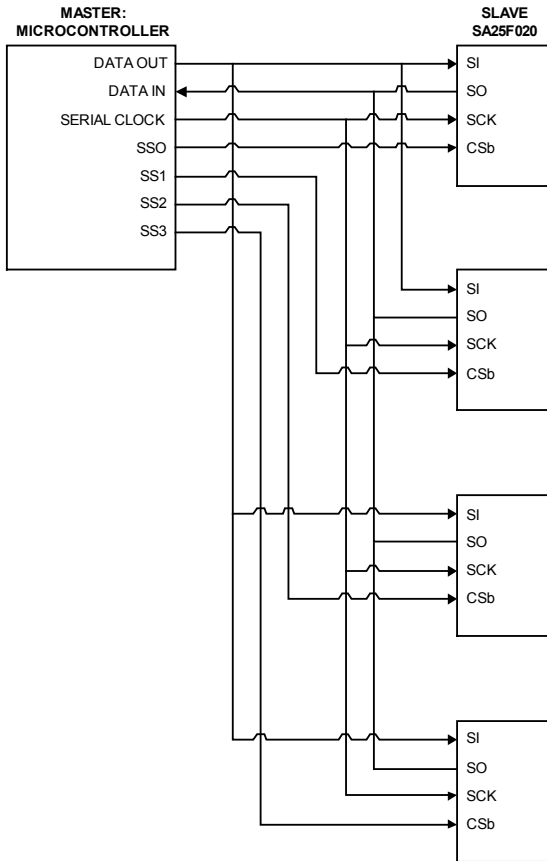

Figure 9. SPI Serial Interface

The SA25F020's SPI consists of an 8-bit instruction register that decodes a specific instruction to be executed. Thirteen different instructions (called *opcodes*) are incorporated in the device for various operations. Table 6 lists the instruction set and the format for proper operation. All opcodes, array addresses and data are transferred in an MSB-first-LSB-last fashion. Detailed information about each of these opcodes is provided for the individual instruction descriptions in the sections that follow.

Table 6. Instruction Set

Instruction Name	Instruction Format	Operation
WREN	0000 0110	Set Write Enable Latch
WRDI	0000 0100	Reset Write Enable Latch
RDSR	0000 0101	Read Status Register
WRSR	0000 0001	Write Status Register
READ	0000 0011	Read Data from Memory Array
FAST_READ	0000 1011	Read Data from Memory Array
Page Program	0000 0010	Write Data to Memory Array
PE	1000 0001	Page Erase
SE	1101 1000	Sector Erase
BE	1100 0111	Bulk Erase
SP	1011 1001	Software Protect
RES	1010 1011	Release from Software Protect Mode
	1010 1011 +3 dummy bytes	Release from Software Protect + Read ID
READ_ID	1010 1011 +3 dummy bytes	Read ID

In addition to the instruction register, the device also contains an 8-bit status register that can be accessed by RDSR and WRSR instructions. The byte defines the Block Write Protection (BP1 and BP0) levels, Write Enable (WEN) status, Busy/Rdy (/RDY) status and Hardware Write Protect (WPBEN) status of the device. Table 7 illustrates the format of the status register.

Table 7. Status Register Format

Bit 7	Bit 6	Bit 5	Bit 4	Bit 3	Bit 2	Bit 1	Bit 0
WPBEN	X	X	X	BP1	BP0	WEN	/RDY

Read Status Register (RDSR)

The RDSR instruction provides read access to the status register. The BUSY/RDY and WREN statuses of the device can also be determined by this instruction. In addition, the Block Write Protection bits indicate the extent of protection employed. In order to determine the status of the device, the value of the /RDY bit can be continuously polled before sending any write instruction.

Table 8. Read Status Register Definition

Bit	Definition
Bit 0 (/RDY)	Bit 0 = 0 (/RDY) indicates that the device is READY. Bit 0 = 1 indicates that a write cycle is in progress.
Bit 1 (WEN)	Bit 1 = 0 indicates that the device is not write enabled. Bit 1 = 1 indicates that the device is write enabled.
Bit 2 (BP0)	Block Write Protect Bit 0
Bit 3 (BP1)	Block Write Protect Bit 1
Bit 7 (WPBEN)	Write Protect Mode Enable Bit

Bit 7 (WPBEN) is Hardware Write Protect mode. If this bit is a 1, this mode is enabled and the status register is write protected.

Bits 6 through 4 are always 0.

Bit 3 (BP1) and Bit 2 (BP0) together indicate a Block Write Protection previously sent to the device.

Bits 0 and 1 are 1 during an internal write cycle.

Bit 1 (WEN) indicates the Write Enable status of the device. This bit is read by executing an RDSR instruction. If this bit is 1, the device is write enabled; if it is 0, it is write disabled.

Bit 0 (/RDY) indicates the Busy/Ready status of the device. This bit is a read-only bit and is read by executing an RDSR instruction. If this bit is 1, the device is busy doing a Program or Erase cycle; if it is 0, the device is ready.

The RDSR command requires the following sequence:

1. The CSb pin is pulled low to select the device and the RDSR opcode is transmitted on the SI pin.
2. The data on the SI pin becomes Don't Care.
3. The data from the status register is shifted out on the SO pins, with the D7 bit first and the D0 bit last, as shown in Figure 10.

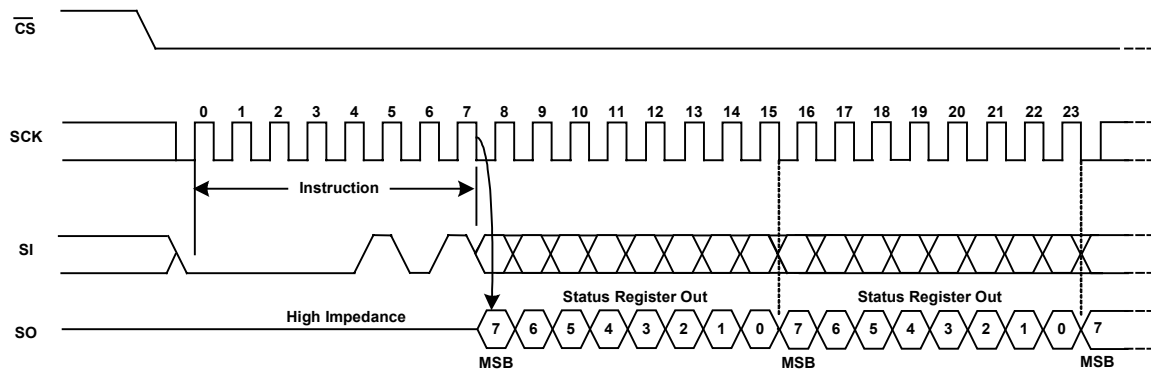

Figure 10. Read Status Register (RDSR) Instruction Sequence

Write Enable (WREN)

The device powers up in the Write Disable state when V_{CC} is applied. All programming instructions must be preceded by a WREN instruction. The instruction sequence is shown in Figure 11, with SO in high impedance.

Write Disable (WRDI)

To protect the device against inadvertent writes, the WRDI instruction disables all programming modes. The WRDI instruction is independent of the WP pin's status. The WREN instruction should be executed after the WRDI instruction to re-enable all programming modes. The instruction sequence is shown in Figure 12, with SO in high impedance.

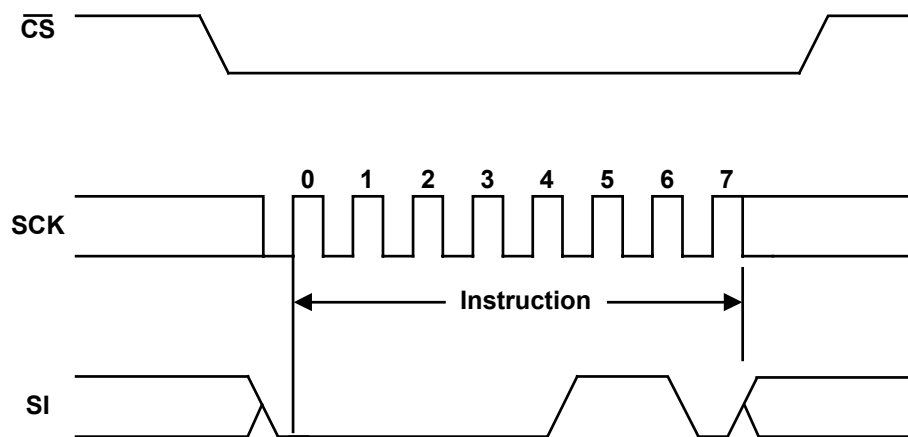

Figure 11. Write Enable (WREN) Instruction Sequence

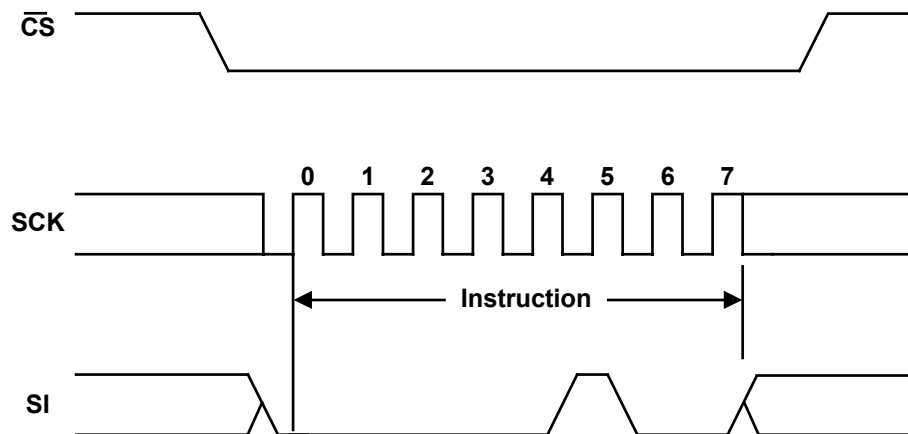

Figure 12. Write Disable (WRDI) Instruction Sequence

Write Status Register (WRSR)

The WRSR instruction enables the user to select one of four levels of protection. The SA25F020 is divided into four array segments. The top quarter, top half or all of the memory segments can be protected (for more details, refer to Table 9). The data within a selected segment is therefore read-only.

Table 9. Block Write Protect Bits

Level	Status Register Bits		Array Addresses Protected
	BP1	BP0	
0	0	0	None
1/4	0	1	30000 - 3FFFF
1/2	1	0	20000 - 3FFFF
All	1	1	00000 - 3FFFF

The WRSR instruction (as shown in Table 10) also allows the user to enable or disable the WPb pin via the WPBEN bit. Hardware write protection is enabled when the WPb pin is low and the WPBEN bit is 1, and disabled when either the WP pin is high or the WPBEN bit is 0. When the device is hardware write protected, writes to the status register are disabled.

NOTE:

When the WPBEN bit is hardware write protected, it cannot be changed back to 0 while the WPb pin is held low.

Table 10. WPBEN Operation

WPb	WPBEN	WEN	Protected Blocks	Un-protected Blocks	Status Register
X	0	0	Protected	Protected	Protected
X	0	1	Protected	Writeable	Writeable
Low	1	0	Protected	Protected	Protected
Low	1	1	Protected	Writeable	Protected
High	X	0	Protected	Protected	Protected
High	X	1	Protected	Writeable	Writeable

The WRSR instruction is enabled:

1. When the WPb pin is held high and the device has been previously write enabled via the WREN instruction.
2. When the WPb pin is held low, the WPBEN bit is 0 and the device has been previously write enabled via the WREN instruction.

The WRSR command requires the following sequence:

1. The CSb pin is pulled low to select the device.
2. The WRSR opcode is then transmitted on the SI pin, followed by the data to be programmed.

The instruction sequence is shown in Figure 13.

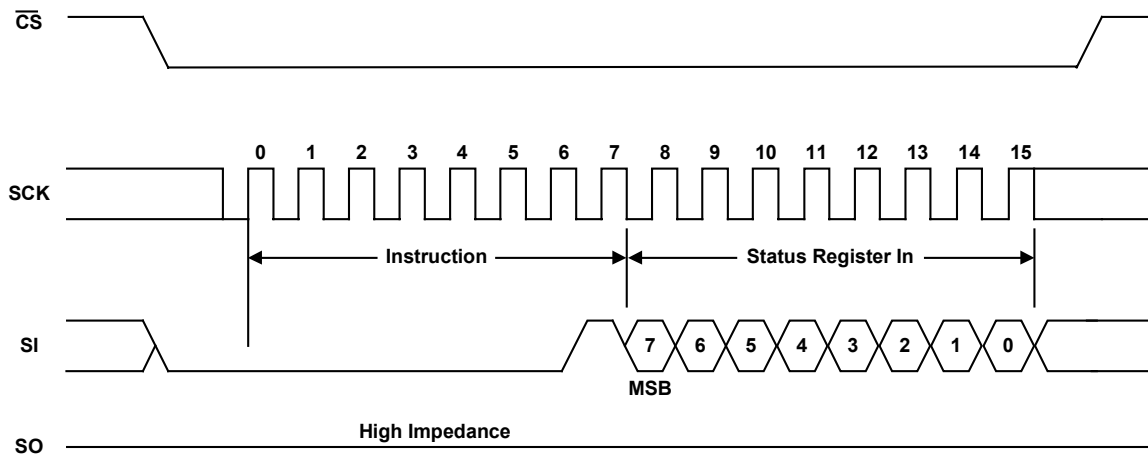

Figure 13. Write Status Register (WRSR) Instruction Sequence

Read Data Bytes (READ)

Reading the memory via the serial SPI link requires the following sequence:

1. After the CSb line is pulled low to select the device, the READ opcode is transmitted via the SI line, followed by the 3-byte address to be read (address bits A23 to A18 are Don't Care).
2. Upon completion, any data on the SI line is ignored.
3. The data (D7-D0) at the specified address is then shifted out onto the SO line. Each bit is shifted out at a maximum SCK frequency of F_{SCK} .

If only one byte is to be read, the CSb line should be driven high after the data comes out. The READ sequence can be continued, as the byte address is automatically incremented and data continues to shift out. When the highest address is reached, the address counter rolls over to the lowest address, enabling the entire memory to be read in one continuous READ cycle. The instruction sequence is shown in Figure 14.

Driving CSb high terminates the READ instruction, which can be done at any time during data output. Any READ instruction executed while an Erase, Program or WRSR cycle is in progress is rejected without having any effect on the cycle in progress.

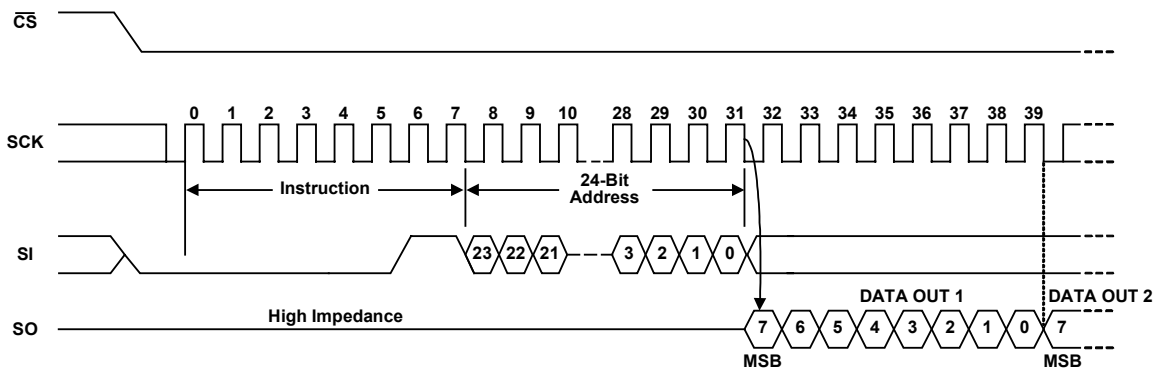

Figure 14. Read (READ) Instruction Sequence

Fast Read (FAST_READ)

The Fast Read instruction is included in the device in order for it to be compatible with other SPI Flash devices. Both the READ and FAST_READ instructions read the memory at the specified SCK frequency (F_{SCK}), with a maximum speed of 25 MHz.

Reading the memory via the serial SPI link requires the following sequence:

1. After the CSb line is pulled low to select the device, the READ opcode is transmitted via the SI line, followed by the 3-byte address and a dummy byte (address bits A23 to A18 are Don't Care).
2. Upon completion, any data on the SI line is ignored.

3. The data (D7-D0) at the specified address is then shifted out onto the SO line. Each bit is shifted out at a maximum frequency of F_{SCK} .

If only one byte is to be read, the CSb line should be driven high after the data comes out. The READ sequence can be continued, as the byte address is automatically incremented and data continues to shift out. When the highest address is reached, the address counter rolls over to the lowest address, enabling the entire memory to be read in one continuous READ cycle. The instruction sequence is shown in Figure 15.

Driving CSb high terminates the FAST_READ instruction, which can be done at any time during data output. Any FAST_READ instruction executed while an Erase or Program cycle is in progress is rejected without having any effect on the cycle in progress.

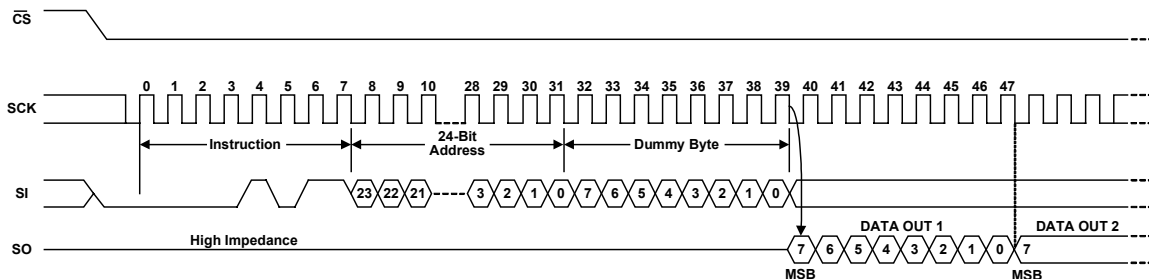

Figure 15. Fast Read (FAST_READ) Instruction Sequence

Page Programming (PP)

The PP instruction allows bytes to be programmed in the memory (changing bits from 1 to 0). In order to program to the SA25F020, two separate instructions must be executed. The device must first be write enabled via the WREN instruction, and then a PP sequence (which consists of four bytes plus data) may be executed. The address of the memory locations to be written must be outside the protected address field location selected by the Block Write Protection level. During an internal Program cycle, all commands are ignored except the RDSR instruction.

A PP instruction requires the following sequence:

- After the CSb line is pulled low to select the device, the PP opcode is transmitted via the SI line, followed by the byte address and the data (D7-D0) to be written.

Programming starts after the CSb pin is brought high. The CSb pin's low-to-high transition must occur during the SCK low time, immediately after the clock in the D0 (LSB) data bit. The instruction sequence is shown in Figure 16, page 26.

As soon as CSb is driven high, the self-timed PP cycle (whose duration is defined as T_{PP}) is initiated. While the Page Program cycle is in progress, the status register may be read to check the value of the Write in Progress (/RDY) bit. The /RDY bit is 1 during the self-timed Page Program cycle, and 0 when it is completed. The Write Enable Latch (WEN) bit is reset at some unspecified time before the cycle is completed.

The SA25F020's PP operation is capable of up to a 256-byte programming, from 1 to 256 bytes at a time (changing bits from 1 to 0), provided that they lie in consecutive addresses on the same page of memory. After each byte is received, the eight low-order address bits are internally incremented by one. If more than 256 bytes of data are transmitted, the address counter rolls over and the previously written data is overwritten. The SA25F020 is automatically returned to the write disable state at the completion of a Write cycle.

NOTES:

1. If the device is not write enabled, the device ignores the PP instruction and returns to the standby state when CSb is brought high. A new CSb falling edge is required to re-initiate the serial communication.
 2. A PP instruction applied to a page that is protected by the Block Protect (BP1, BP0) bits (as described in Table 8, page 18, and Table 9, page 21) is not executed.
-

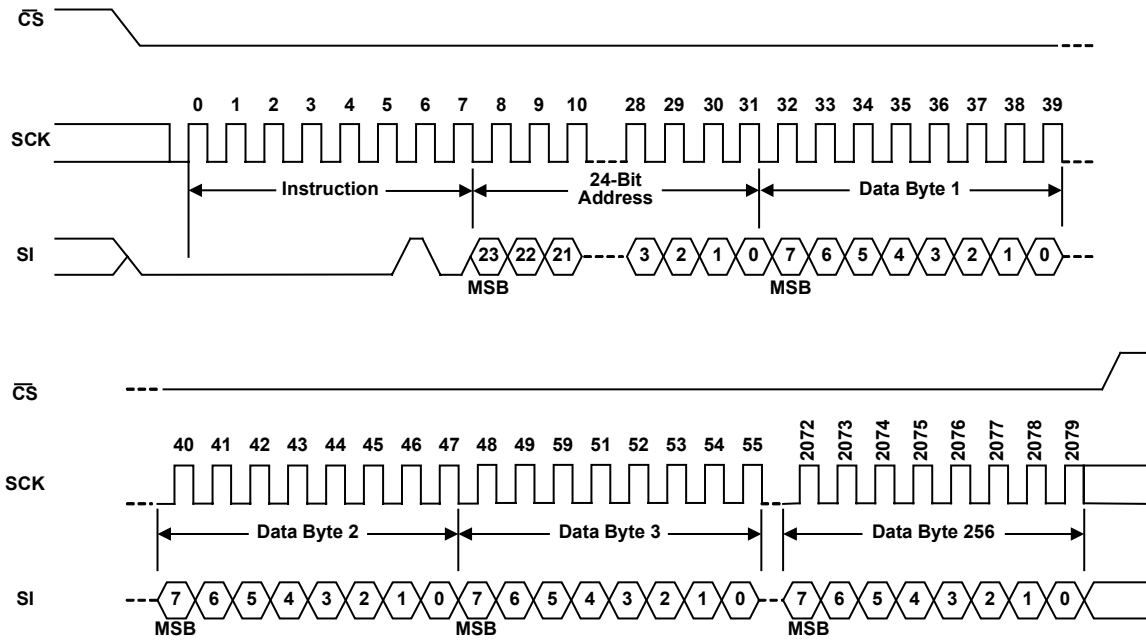

Figure 16. Page Programming (PP) Instruction Sequence

Page Erase (PE)

The PE instruction sets all 256 bytes in the selected page to 1. Before it can be executed, two separate instructions must be carried out. The device must first be write enabled via the WREN instruction, and then a PE sequence, which consists of one opcode byte and three data bytes may be executed. The address of the memory locations to be written must be inside the page to be erased and outside the protected address field location selected by the Block Write Protection level. During an internal PE cycle, all commands are ignored except the RDSR instruction.

A PE instruction requires the following sequence:

1. After the CSb line is pulled low to select the device, the PE opcode is transmitted via the SI line, followed by the 3-byte address.
2. Erasing begins after the CSb pin is brought high. The CSb pin's low-to-high transition must occur during the SCK low time, immediately after the clock in the last address bit.

As soon as CSb is driven high, the self-timed PE cycle (whose duration is defined as T_{PE}) is initiated. While the PE cycle is in progress, the status register may be read to check the value of the /RDY bit. The /RDY bit is 1 during the self-timed PE cycle, and 0 when it is completed. The WEN bit is reset at some unspecified time before the cycle is completed. The instruction sequence is shown in Figure 17.

The SA25F020 is automatically returned to the Write Disable state at the completion of a PE cycle.

NOTES:

1. If the device is not write enabled, the device ignores the PE instruction and returns to the standby state when CSb is brought high. A new CSb falling edge is required to re-initiate the serial communication.
2. A PE instruction applied to a page that is protected by the Block Protect (BP1, BP0) bits (as described in Table 8, page 18, and Table 9, page 21) is not executed.

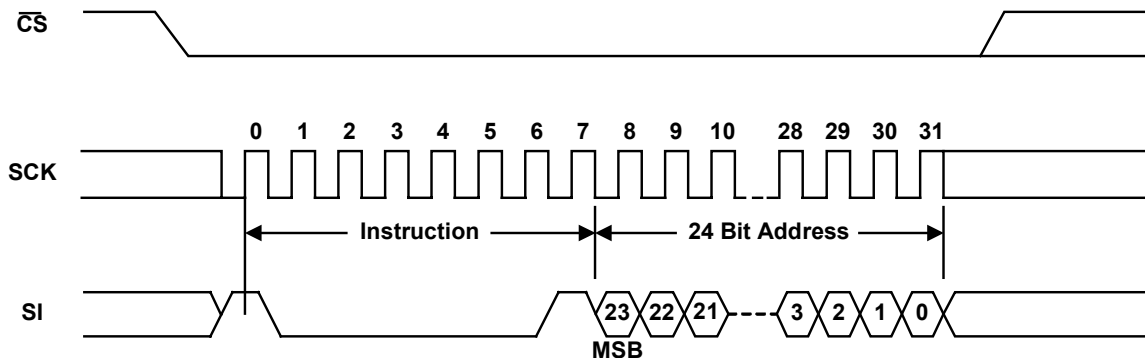

Figure 17. Page Erase (PE) Instruction Sequence

Sector Erase (SE)

The SE instruction sets all 512 Kb in the selected sector to 1. Before it can be executed, two separate instructions must be carried out. The device must first be write enabled via the WREN instruction, and then a SE sequence, which consists of four bytes, may be executed. The address of the memory locations to be written must be inside the sector to be erased and outside the protected address field location selected by the Block Write Protection level. During an internal SE cycle, all commands are ignored except the RDSR instruction.

A SE instruction requires the following sequence:

1. After the CSb line is pulled low to select the device, the SE opcode is transmitted via the SI line, followed by the 3-byte address.
2. Erasing begins after the CSb pin is brought high. The CSb pin's low-to-high transition must occur during the SCK low time, immediately after the clock in the last address bit.

As soon as CSb is driven high, the self-timed SE cycle (whose duration is defined as T_{SE}) is initiated. While the SE cycle is in progress, the status register may be read to check the value of the /RDY bit. The /RDY bit is 1 during the self-timed SE cycle, and 0 when it is completed. The WEN bit is reset at some unspecified time before the cycle is completed. The instruction sequence is shown in Figure 18.

The SA25F020 is automatically returned to the write disable state at the completion of an SE cycle.

NOTES:

1. If the device is not write enabled, the device ignores the SE instruction and returns to the standby state when CSb is brought high. A new CSb falling edge is required to re-initiate the serial communication.
2. A SE instruction applied to a sector that is protected by the Block Protect (BP1, BP0) bits (as described in Table 8, page 18, and Table 9, page 21) is not executed.

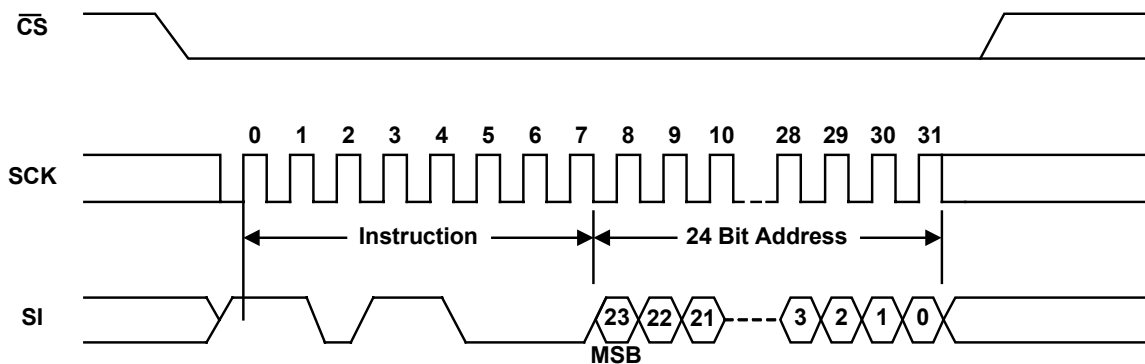

Figure 18. Sector Erase (SE) Instruction Sequence

Bulk Erase (BE)

The BE instruction sets all bits in the memory array to 1. Before it can be executed, two separate instructions must be carried out. The device must first be write enabled via the WREN instruction, and then a BE sequence, which consists of four bytes plus data, may be executed. The address of the memory locations to be written must be outside the protected address field location selected by the Block Write Protection level. During an internal BE cycle, all commands are ignored except the RDSR instruction.

A BE instruction requires the following sequence:

1. After the CSb line is pulled low to select the device, the BE opcode is transmitted via the SI line.
2. Erasing begins after the CSb pin is brought high. The CSb pin's low-to-high transition must occur during the SCK low time, immediately after the clock in the last opcode bit.

As soon as CSb is driven high, the self-timed BE cycle (whose duration is defined as T_{BE}) is initiated. While the BE cycle is in progress, the status register may be read to check the value of the /RDY bit. The /RDY bit is 1 during the self-timed BE cycle, and 0 when it is completed. The WEN bit is reset at some unspecified time before the cycle is completed. The instruction sequence is shown in Figure 19.

The SA25F020 is automatically returned to the Write Disable state at the completion of a BE cycle.

NOTES:

1. If the device is not write enabled, the device ignores the BE instruction and returns to the standby state when CSb is brought high. A new CSb falling edge is required to re-initiate the serial communication.
2. A BE instruction can be applied only if both Block Protect (BP1, BP0) bits (as described in Table 8, page 18, and Table 9, page 21) are 0.

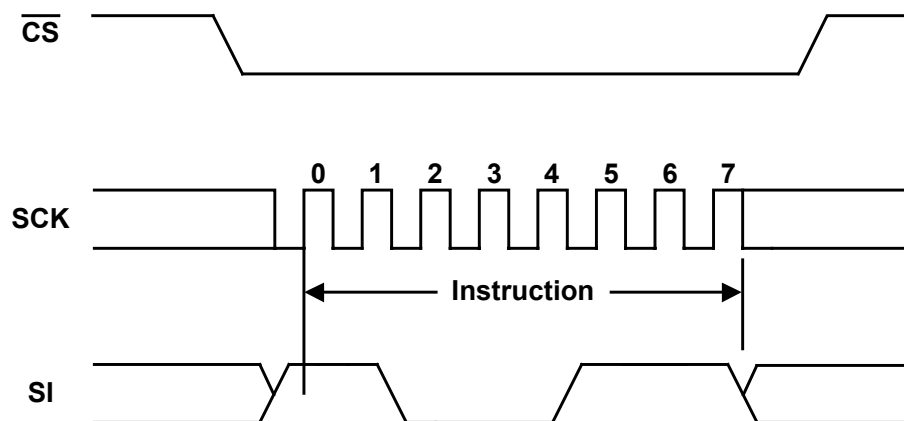

Figure 19. Bulk Erase (BE) Instruction Sequence

Software Protection (SP)/ Deep Powerdown (DP)

The DP instruction is included in the device in order to be compatible with other SPI Flash devices, and is identical to the SP instruction.

The SA25F020's low standby current of 1 μA is the same in both DP and Standby modes. It is recommended that the standard Standby mode be used for the lowest power current draw, as well as an extra SP mechanism while the device is not in active use. This is due to the fact that while in this mode, the device ignores all Write, Program and Erase instructions.

The SP instruction is entered by driving CSb low, followed by the instruction code on the SI pin. CSb must be driven low for the entire duration of the sequence. The instruction sequence is shown in Figure 20.

CSb must be driven high after the eighth bit of the instruction code has been latched in; otherwise, the SP instruction is not executed. As soon as CSb is driven high, it requires a delay of t_{DP} before SP mode is entered.

Once the device has entered SP mode, all instructions are ignored except the Release from Software Protect and Read Electronic Signature (RES) instructions, which release the device from this mode. RES instructions also enable the Electronic Signature to be read on the SO pin.

SP mode automatically stops at powerdown, and the device always powers up in the Standby mode. Any SP instruction executed while an Erase, Program or WRSR cycle is in progress is rejected without having any effect on the cycle in progress.

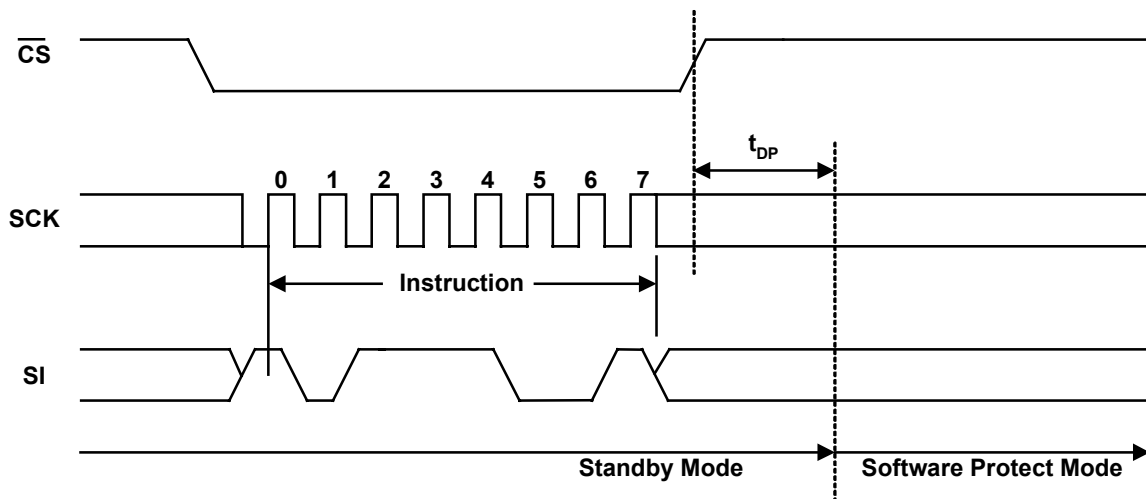

Figure 20. Software Protection Instruction Sequence

Release from Software Protect (RES)

Once the device has entered SP mode, all instructions are ignored except the RES mode.

Any RES instruction executed while an Erase, Program or Write Status Register cycle is in progress is not decoded, and has no effect on the cycle that is in progress.

The device is first selected by driving CSb low, followed by an 8-bit instruction byte, with each bit being latched in on SI during the rising edge of SCK.

Driving CSb high after the 8-bit instruction byte has been received by the device, but before the whole of the 8-bit Electronic Signature has been transmitted for the first time (as shown in Figure 21), will still ensure that the device is put into Standby mode. The transition to Standby mode is delayed by t_{RES} , and CSb must remain high for at least $t_{RES(max)}$, as specified in Table 4 on page 10. Once in Standby mode, the device waits to be selected, so that it can receive, decode and execute instructions.

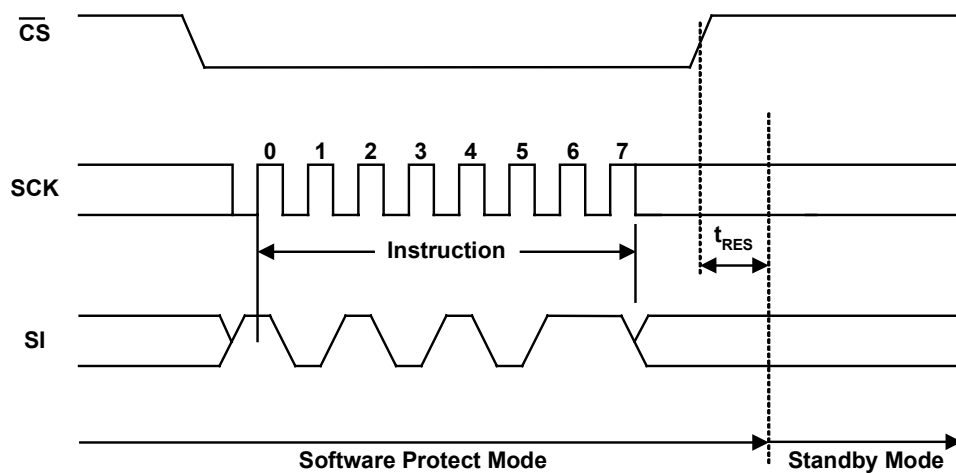

Figure 21. Release from Software Protect (RES) Instruction Sequence

Release from Software Protection and Read Electronic Signature (RES)

Once the device has entered SP mode, all instructions are ignored except the RES mode. The instruction can also be used to read the 8-bit Electronic Signature of the device on the SO pin.

The RES instruction always provides access to the Electronic Signature of the device (except while an Erase, Program or Write Status Register cycle is in progress), and can be applied even if SP mode has not been entered. Any RES instruction executed while an Erase, Program or Write Status Register cycle is in progress is not decoded, and has no effect on the cycle in progress.

This instruction serves a second purpose as well. The device features an 8-bit Electronic Signature, whose value for the SA25F020 is 11h. This can be read using the RES instruction.

The device is first selected by driving CSb low. The instruction code is followed by three dummy bytes, each bit being latched in on SI during the rising edge of SCK.

The 8-bit Electronic Signature, which stored in the memory, is then shifted out on SO, with each bit being shifted out during the falling edge of SCK. The instruction sequence is shown in Figure 22.

Driving CSb high after the Electronic Signature has been read at least once terminates the RES instruction. Sending additional clock cycles on SCK, while CSb is driven low causes the Electronic Signature to be output repeatedly.

When CSb is driven high, the device is put into Standby mode. The transition to Standby mode is delayed by t_{RES} , and CSb must remain high for at least $t_{RES(max)}$, as specified in Table 4 on page 10. Once in Standby mode, the device waits to be selected, so that it can receive, decode and execute instructions.

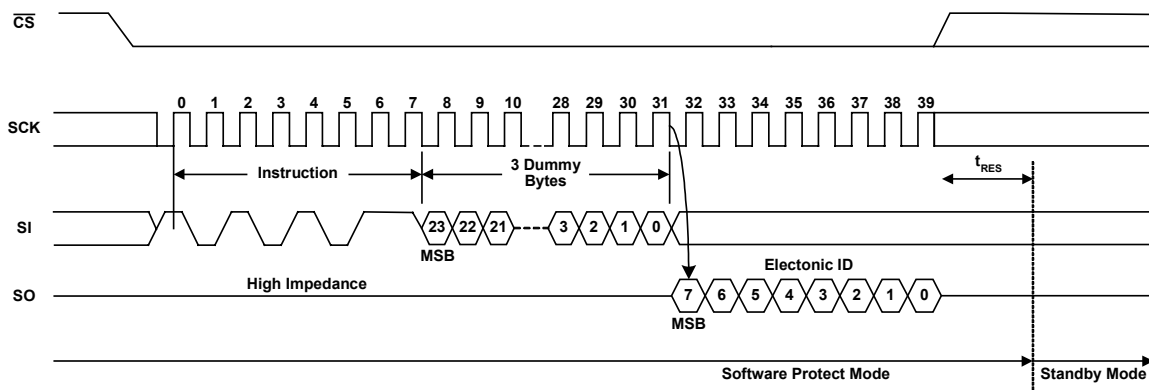

Figure 22. Release from Software Protection and Read Electronic Signature (RES) Instruction Sequence

Powerup and Powerdown

The device must not be selected at powerup or powerdown (that is, CSb must follow the voltage applied on V_{CC}) until V_{CC} reaches the correct value, as follows:

- $V_{CC}(\text{min})$ at powerup, and then for a further delay of t_{PU} (as described in Table 11)
- V_{SS} at powerdown

A simple pull-up resistor on CSb can usually be used to insure safe and proper powerup and powerdown. To avoid data corruption and inadvertent write operations during powerup, a Power On Reset (POR) circuit is included. The logic inside the device is held at reset while V_{CC} is less than the POR threshold value (V_{POR}), all operations are disabled and the device does not respond to any instructions.

The device ignores all instructions until a time delay of t_{PU} has elapsed after the moment that V_{CC} rises above the VWI threshold. However, correct operation of the device is not guaranteed if by this time V_{CC} is still below $V_{CC}(\text{min})$. No Write Status Register, Program or Erase instructions should be sent until t_{PU} reaches the minimum V_{CC} threshold after V_{CC} .

At powerup, the device is in Standby mode (not SP mode) and the WEN bit is reset.

Normal precautions must be taken for supply rail decoupling to stabilize the V_{CC} feed. Each device in a system should have the V_{CC} rail decoupled by a suitable capacitor close to the package pins (this capacitor is generally of the order of 0.1 μF).

All operations are disabled and the device does not respond to any instructions when V_{CC} drops at powerdown from the operating voltage to below the V_{POR} threshold. (The designer must be aware that if a powerdown occurs while a Write, Program or Erase cycle is in progress, data corruption can result.)

Table 11. Powerup

Symbol	Parameter	Min.	Max.	Unit
V_{POR}	POR Threshold Value	2.2	2.4	V
t_{PU}	$V_{CC}(\text{min})$ to CS low	2		ms

Physical Dimensions

All measurements are in inches (millimeters), unless otherwise specified.

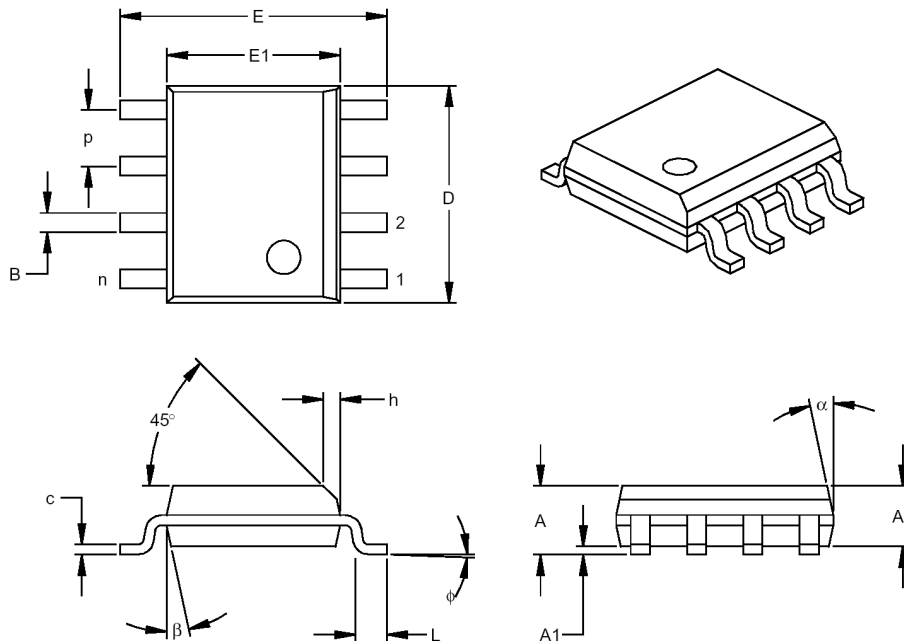

Dimension Limits	Units	INCHES*			MILLIMETERS		
	n	MIN	NOM	MAX	MIN	NOM	MAX
Number of Pins	n		8			8	
Pitch	p		.050			1.27	
Overall Height	A	.053	.061	.069	1.35	1.55	1.75
Molded Package Thickness	A2	.052	.056	.061	1.32	1.42	1.55
Standoff §	A1	.004	.007	.010	0.10	0.18	0.25
Overall Width	E	.228	.237	.244	5.79	6.02	6.20
Molded Package Width	E1	.146	.154	.157	3.71	3.91	3.99
Overall Length	D	.189	.193	.197	4.80	4.90	5.00
Chamfer Distance	h	.010	.015	.020	0.25	0.38	0.51
Foot Length	L	.019	.025	.030	0.48	0.62	0.76
Foot Angle	φ	0	4	8	0	4	8
Lead Thickness	c	.008	.009	.010	0.20	0.23	0.25
Lead Width	B	.013	.017	.020	0.33	0.42	0.51
Mold Draft Angle Top	α	0	12	15	0	12	15
Mold Draft Angle Bottom	β	0	12	15	0	12	15

* Controlling Parameter

§ Significant Characteristic

Notes:

Dimensions D and E1 do not include mold flash or protrusions. Mold flash or protrusions shall not exceed .010" (0.254mm) per side.

Figure 23. 8-pin SOIC Package

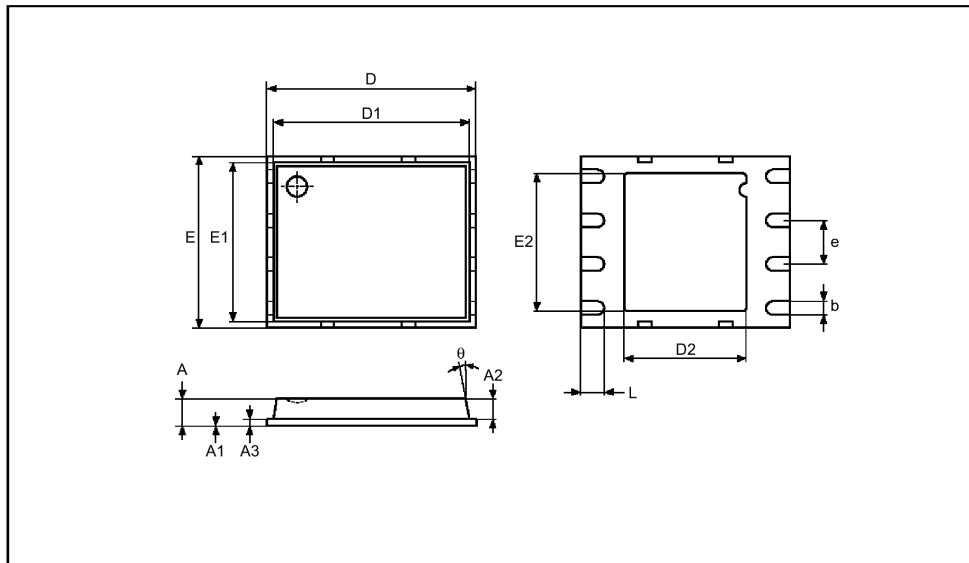

Note: Drawing is not to scale.

Symb.	mm			inches		
	Typ.	Min.	Max.	Typ.	Min.	Max.
A	0.85		1.00	0.0335		0.0394
A1		0.00	0.05		0.0000	0.0020
A2	0.65			0.0256		
A3	0.20			0.0079		
b	0.40	0.35	0.48	0.0157	0.0138	0.0189
D	6.20			0.2400		
D1	5.75			0.2264		
D2	3.40	3.20	3.60	0.1339	0.1260	0.1417
E	5.00			0.1969		
E1	4.75			0.1870		
E2	4.00	3.80	4.20	0.1575	0.1496	0.1654
e	1.27			0.0500		
L	0.60	0.50	0.75	0.0236	0.0197	0.0295
θ			12°			12°

Figure 24. 8-pin MLF Leadless Package

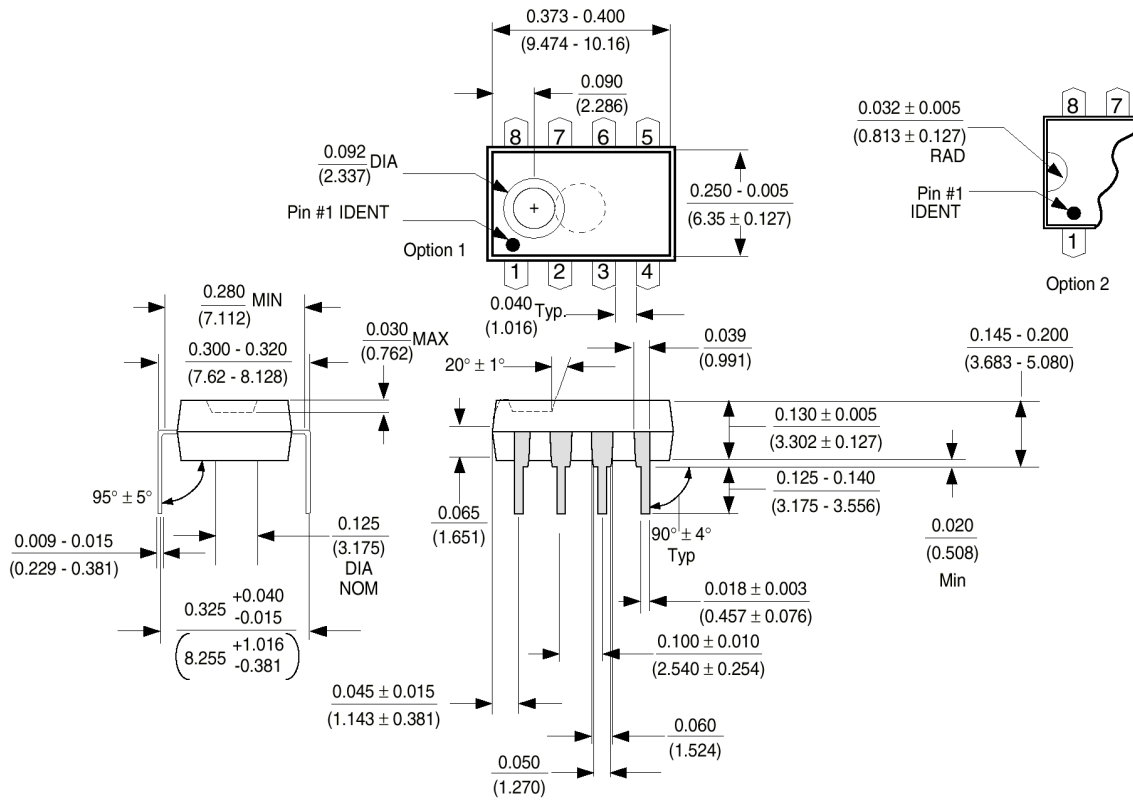

Figure 25. Molded Dual-in-line Package (N) Package Number N08E

Contact Information

International Headquarters

Saifun Semiconductors Ltd.
ELROD Building
45 Hamelach St.
Sappir Industrial Park
Netanya 42504
Israel

Tel.: +972-9-892-8444

Fax: +972-9-892-8445

Email: tech_support@saifun.com

<http://www.saifun.com>

United States

Saifun Semiconductors Inc.
2350 Mission College Blvd.
Suite 1070
Santa Clara, CA 95054
U.S.A.

Tel: +1-408-982-5888

Fax: +1-408-982-5890

Revision History

Rev	Date	Description of Change
0.0	26-May-03	Initial Release
1.0	24-Jul-03	Modified Ordering Information

© Saifun Semiconductors Ltd. 2003

Saifun reserves the right, without notice, to change any of the products described in this guide, in order to improve functionality, reliability or design. Saifun assumes no liability arising from the application or use of any product described in this guide; and under its patent rights, gives no authorization for the use of this product or associated products. The Buyer will not hold Saifun responsible for direct or indirect damages and expenses, as well as any claim of injury or death, associated with the unauthorized use, including claims of manufacture or design negligence.

Saifun and Saifun NROM are trademarks or registered trademarks of Saifun Semiconductors Ltd.
Other company and brand products and service names are trademarks or registered trademarks of their respective holders.

Life Support Policy

Saifun's products are not authorized for use as critical components in life support devices or systems without the express written approval of the President of Saifun Semiconductors Ltd. As used herein:

1. Life support devices or systems are devices or systems which, (a) are intended for surgical implant into the body, or (b) support or sustain life, and whose failure to perform, when properly used in accordance with instructions for use provided in the labeling, can be reasonably expected to result in a significant injury to the user.
2. A critical component is any component of a life support device or system whose failure to perform can be reasonably expected to cause the failure of the life support device or system, or to affect its safety or effectiveness.