

DATA SHEET

SA9024 **900 MHz transmit modulator and** **1.3 GHz fractional-N synthesizer**

Objective specification

1997 Aug 01

900 MHz transmit modulator and 1.3 GHz fractional-N synthesizer

SA9024

DESCRIPTION

This specification defines the requirements for a transmitter modulator and fractional-N synthesizer IC to be used in cellular telephones which employ the North American Dual Mode Cellular System (IS-136).

FEATURES

- Low current from 3.75V supply
- Low phase noise
- Main loop with internal charge pump and fractional compensation
- 3-line serial interface bus
- Power down for the synthesizers
- Speedup mode for faster switching

APPLICATIONS

- Cellular phones
- Portable battery-powered radio equipment.

GENERAL DESCRIPTION

The SA9024 BICMOS device integrates:

- Main channel synthesizer
- Auxiliary synthesizer
- Transmit offset synthesizer and oscillator
- I/Q modulator
- Power control

- Reference and clock buffers
- Control logic for programming and power down modes

PIN CONFIGURATION

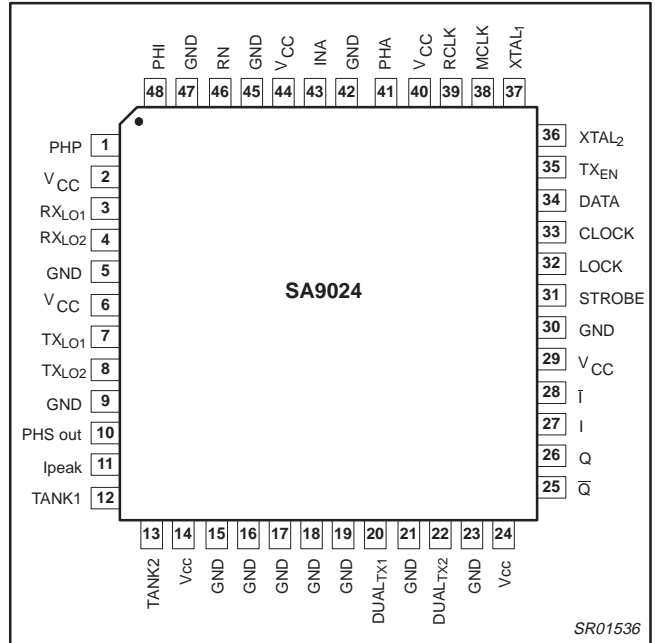

Figure 1. Pin Configuration

QUICK REFERENCE DATA

SYMBOL	PARAMETER	CONDITIONS	MIN.	TYP.	MAX.	UNIT
V _{CC}	Supply voltage	V _{CC}	3.6	3.75	3.9	V
I _{CC}	Supply current		–	TBD	–	mA
I _{CC_save}	Total supply current in power-down mode		–	TBD	–	mA
f _{VCO}	Input frequency		800	–	1300	MHz
f _{AUX}	Input frequency		10	–	500	MHz
f _{XTAL}	Crystal reference input frequency		10	–	40	MHz
f _{PC}	Maximum phase comparator frequency	Main and Aux loops	–	–	5	MHz
T _{amb}	Operating ambient temperature		–40	–	+85	°C

ORDERING INFORMATION

TYPE NUMBER	PACKAGE		
	NAME	DESCRIPTION	VERSION
SA9024	LQFP48	Plastic low profile quad flat package; 48 leads; body 7x7x1.4 mm	SOT313-2

900 MHz transmit modulator and 1.3 GHz fractional-N synthesizer

SA9024

CONNECTIONS

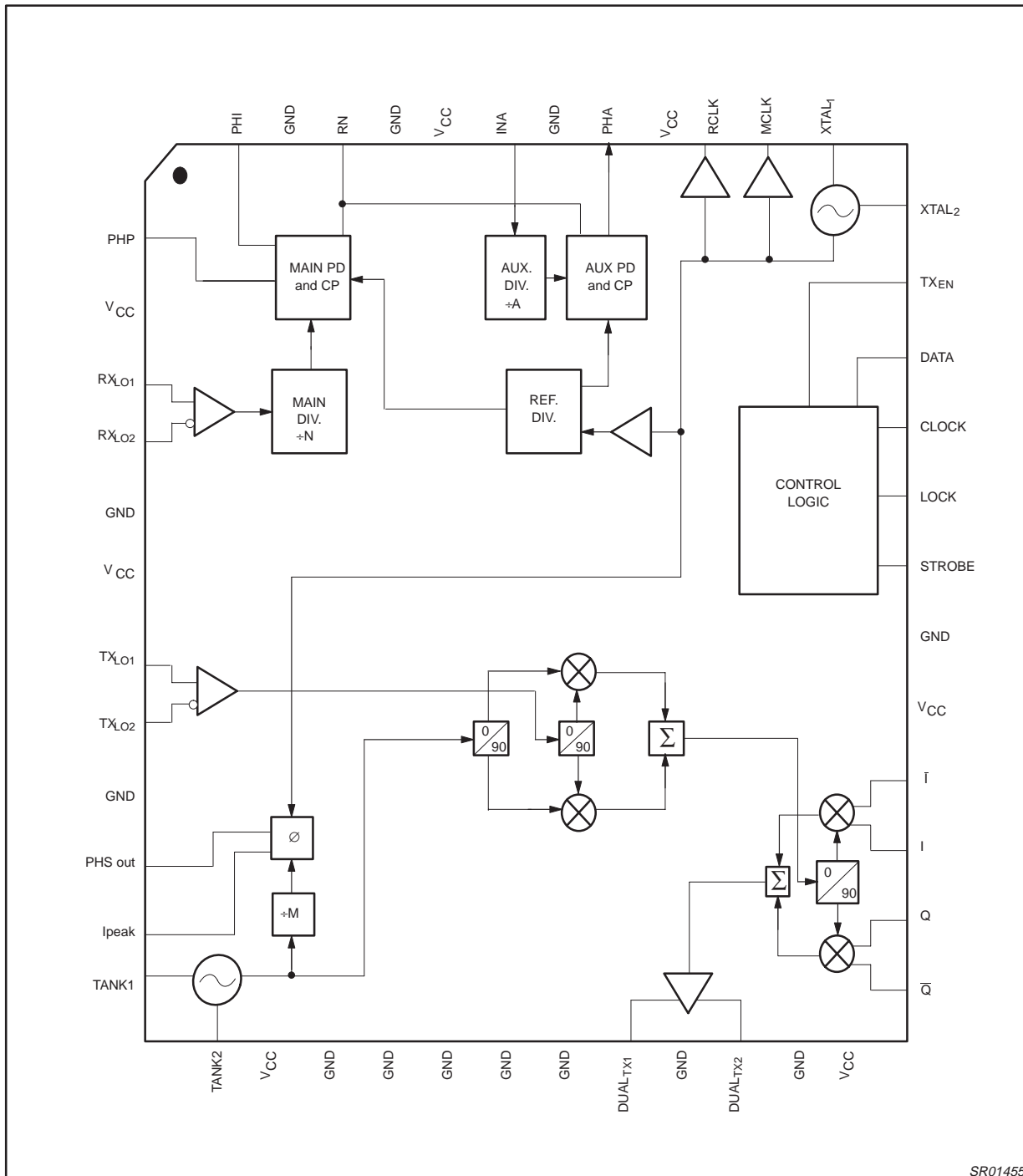

Figure 2. SA9024 Block Diagram

SR01455

900 MHz transmit modulator and 1.3 GHz fractional-N synthesizer

SA9024

PIN DESCRIPTIONS

PIN NO.	PIN	DESCRIPTION
1	PHP	Proportional charge pump output
2	V _{CC}	Digital supply voltage
3	RX _{LO1}	Differential LO input
4	RX _{LO2}	Differential LO input
5	GND	Digital Ground
6	V _{CC}	Tank supply voltage
7	TX _{LO1}	Differential Transmit LO Input
8	TX _{LO2}	Differential Transmit LO Input
9	GND	Tank Ground
10	PHS OUT	Charge pump output (transmit offset)
11	I _{PEAK}	PHS out current set resistor
12	TANK1	VCO differential tank
13	TANK2	VCO differential tank
14	V _{CC}	Tx supply voltage
15	GND	Tx Ground
16	GND	Tx Ground
17	GND	Tx Ground
18	GND	Tx Ground
19	GND	Tx Ground
20	DUALTX1	Dual mode RF output
21	GND	Tx Ground
22	DUALTX2	Dual mode RF output
23	GND	Tx Ground

24	V _{CC}	Tx supply voltage
25	Q̄	Inverting quadrature input
26	Q	Non-Inverting quadrature input
27	Ī	Non-inverting in phase modulation input
28	I	Inverting in phase modulation input
29	V _{CC}	Tx supply voltage
30	GND	Tx Ground
31	STROBE	Data input latch enable
32	LOCK	Lock detect
33	CLOCK	Serial clock input
34	DATA	Serial data input
35	TX _{EN}	Transmit enable
36	XTAL ₂	Crystal Oscillator emitter input
37	XTAL ₁	Crystal Oscillator base Input
38	MCLK	Buffered oscillator output
39	RCLK	Buffered oscillator output
40	V _{CC}	REF supply voltage
41	PHA	Auxiliary charge pump output
42	GND	REF Ground
43	INA	RX _{IF} input
44	V _{CC}	CP supply voltage
45	GND	CP Ground
46	RN	CP current set resistor
47	GND	CP Ground
48	PHI	Integral charge pump output

900 MHz transmit modulator and 1.3 GHz fractional-N synthesizer

SA9024

OPERATING MODES & POWER DOWN CONTROL

There are two power saving modes of operation which the SA9024 can be put into, dependent on the status of the system. The intention of these different modes is to disable circuitry that is not in use at the time in order to reduce power consumption. During sleep mode, only circuitry which is required to provide a master clock to

the digital portion of the system is enabled. During receive mode, circuitry which is used to perform the receive function and provide a master clock is enabled. In transmit mode all the functions of the chip are enabled which are required to perform transmit, receive and provide master clock.

SA9024 POWER MODE TRUTH TABLE

Enabled	Sleep Mode		Receive Mode		Transmit Mode	
	yes	no	yes	no	yes	no
Crystal Oscillator	✓		✓		✓	
Phase detector and charge pump (transmit offset)		✓		✓	✓	
VCO		✓		✓	✓	
SSB Up-converter		✓		✓	✓	
MCLK Buffer	✓		✓		✓	
RCLK Buffer		✓	✓		✓	
-M offset loop divider		✓		✓	✓	
TX _{LO} Buffer		✓		✓	✓	
RX _{LO} Buffer		✓	✓		✓	
I/Q Modulator		✓		✓	✓	
Variable Gain Amp.		✓		✓	✓	
Control Logic	✓		✓		✓	
Main Divider		✓	✓		✓	
Reference Divider		✓	✓		✓	
Auxiliary Divider		✓	✓		✓	
Main Phase Detector and charge pump		✓	✓		✓	
Auxiliary Phase Detector and charge pump		✓	✓		✓	
Lock Detect		✓	✓		✓	

900 MHz transmit modulator and 1.3 GHz fractional-N synthesizer

SA9024

ABSOLUTE MAXIMUM RATINGS

SYMBOL	PARAMETER	VALUE		UNIT
		MIN.	MAX.	
V _{CC}	Supply voltage	-0.3	+4.5	V
V _{IN}	Voltage applied to any other pin	-0.3	V _{CC} +0.3	V
P _N	Power dissipation, T _A = 25°C (still air)		980	mW
T _{JMAX}	Operation junction temperature		TBD	°C
P _{MAX}	Power input/output		+10/+14	dBm
I _{MAX}	DC current into any I/O pin	-10	+10	mA
T _{STG}	Storage temperature	-65	+150	°C
T _o	Operating temperature	-40	+85	°C

DC ELECTRICAL CHARACTERISTICS

V_{CC} = +3.75 V; T_A = 25°C; unless otherwise stated.

SYMBOL	PARAMETER	TEST CONDITIONS	LIMITS			UNITS
			MIN	TYP	MAX	
V _{CC}	Power supply range		3.6	3.75	3.9	V
I _{CC}	Supply current	Sleep mode		2		mA
		Standby mode		17		
		Operating: full power analog		95		
		Operating: full power digital DUAL ¹		52		
I / \bar{I}	In-phase differential input	quiescent		V _{CC} /2		V
Q / \bar{Q}	Quadrature phase differential input	quiescent		V _{CC} /2		V
V _{IL}	Clock, Data, Strobe, TX _{EN}	Input logic low	-0.3		0.3 × V _{CC}	V
V _{IH}	Clock, data, strobe, TX _{EN}	Input logic high	0.7 × V _{CC}		V _{CC} +0.3	V
T _A	Ambient temperature range		-40	+25	+85	°C
Digital Outputs Lock						
V _{OL}	Output voltage LOW	I _O = 2mA			0.4	V
V _{OH}	Output voltage HIGH	I _O = -2mA	V _{CC} - 0.4			V
Charge Pump Current Setting Resistor Input; R_N, R_{Ipeak}						
R _N	External resistor to ground		6	7.5	24	kΩ
R _{Ipeak}	External resistor to ground			4.7		kΩ
V _{RN}	Regulated voltage	R _N = 7.5 kΩ		1.23		V
V _{Ipeak}	Regulated voltage	R _{Ipeak} = 4.7 kΩ		1.3		V
I _{Ipeak}	PHSOUT programming	R _{Ipeak} = 4.7 kΩ		0.26		mA
PHS _{gain}	PHSOUT gain	R _{Ipeak} = 4.7 kΩ		24 × I _{Ipeak}		mA
Kφ	PD phase gain	Transmit offset PLL in phase lock		4.33		mA/rad
Charge Pump Outputs (including fractional compensation pump, not PHS) R_N = 7.5 kΩ						
I _{OPH}	Charge pump output current error versus expected current.		-15		15	%
I _{MATCH}	Sink to source current matching	V _{PHX} = V _{CC} /2	-5		5	%
	Current output variation versus V _{PHX}	V _{PHX} in compliance range	-10		10	%
V _{PH}	Charge pump off, leakage current	V _{PHX} = V _{CC} /2	-10	± 1	10	nA
	Charge pump voltage compliance ³		0.7		V _{CC} - 0.8	V
Charge Pump Outputs (only PHS) R_{Ipeak} = 4.7 kΩ						
I _{OPH}	Charge pump output current error versus expected current.		-15		15	%
I _{MATCH}	Sink to source current matching	V _{PHS} = V _{CC} /2	-10		10	%

900 MHz transmit modulator and 1.3 GHz fractional-N synthesizer

SA9024

	Current output variation versus V_{PH}	V_{PHS} in compliance range	-25		25	%
V_{PH}	Charge pump voltage compliance		0.5		$V_{CC}-0.5$	V

AC ELECTRICAL CHARACTERISTICS

$V_{CC} = +3.75$ V; $T_A = 25^\circ\text{C}$; unless otherwise stated.

SYMBOL	PARAMETER	TEST CONDITIONS	LIMITS			UNITS
			MIN	TYP	MAX	
Modulator						
$TX_{LO\ 1/2}$	Transmit LO input (AC-coupled; 50Ω single-ended, 100Ω differential)	Input power Frequency range	-13 900		-10 1100	dBm MHz
VSWR				2:1		
TANK1/2	VCO tank differential inputs	Frequency range	90		180	MHz
+M	PLL offset divider	Maximum input frequency	180			MHz
XTAL ₁	Osc. transistor base	Osc. frequency	10		40	MHz
XTAL ₂	Osc. transistor emitter	Osc. frequency	10		40	MHz
XO	Negative resistance			-100		Ω
RCLK, MCLK	Reference buffer output Frequency range Output levels Harmonic content	$Z_{LOAD} = 5k\Omega 7\text{ pF}$	10 0.7	1.0	40 1.4 -10	MHz V_{P-P} dBc
TX_{EN}	Transmit enable	Transmit enable Transmit disable		$TX_{EN} = 1$ $TX_{EN} = 0$		Logic
Q / \bar{Q} I / \bar{I}	Baseband in-phase differential inputs	Maximum frequency Diff. mod. level Diff. input impedance DC bias point	1.8 0.8 10.0 1.8	0.9 $V_{CC}/2$	1.0 2.55	MHz V_{P-P} kΩ V
TX_{RF}	TX_{RF} operating range		820		920	MHz
DUAL _{TX}	DUAL output SE=1, $TX_{EN}=1$ (with external matching) (50Ω)	AMPS/DAMPS	820		853	MHz
DUAL _{TX}	Differential output, (DUAL _{TX}) open-collector, matched to 200Ω differential impedance	Output level (avg. min., I and Q quad., 0dB VGA) Gain flatness	+6.0	+10 1	+13.5	dBm dB
DUAL _{TX}	Linearity worst case intermod. products (0dB VGA OR +6 dBm, whichever is less, I & Q in-phase)	3rd-order 5th-order 7th-order		-42 -55 -65	-30 -45 -53	dBc
DUAL _{TX}	Carrier suppression (I & Q in quadrature)	VGA = 0dB VGA = -38dB		-45 -33	-30	dBc
DUAL _{TX}	Sideband suppression (I & Q in quadrature)			-45	-32	dBc
DUAL _{TX}	Spurious output	2 to 284 MHz			-45	dBc
		824 to 849 MHz			-47	
		849 to 869 MHz			-45	
		869 to 894 MHz			-104	dBm
		894 to 8490 MHz			-45	dBc
DUAL _{TX}	TX_{LO} up-conversion products	TX_{LO}			-21	dBc
		Upper Side Band			-21	
		$TX_{LO} \pm 3 \times TX_{OFFSET}$			-36	
		Harmonics ≤ 10 th			-21	
DUAL _{TX}	Broad-band noise (0dB VGA or +6 dBm, whichever is less)	869 to 894 MHz			-123	dBm/Hz
DUAL _{TX}	Adjacent channel noise power	@ 30 kHz			-95	dBc/Hz
DUAL _{TX}	Alternate channel noise power	@ 60 kHz			-101	dBc/Hz

900 MHz transmit modulator and 1.3 GHz fractional-N synthesizer

SA9024

Synthesizer						
Main Divider						
f_{MAX}	Input frequency range		800		1300	MHz
	Input harmonics	No multi-clocking	-10			dBc
$RX_{LO\ 1/2}$	Synthesizer LO input (AC-coupled; external shunt 50Ω single-ended, 100Ω differential)	Input power	-20		0	dBm
Reference Divider						
f_{MAX}	Input frequency RANGE		10		40	MHz
	Input harmonics	No multi-clocking	-10			dBc
Auxiliary Divider						
f_{MAX}	Input frequency RANGE		10		500	MHz
	Input harmonics	No multi-clocking	-10			dBc
V_{INA}	Input signal amplitude		0.200			V_{P-P}
Serial Interface						
f_{CLOCK}	Clock frequency				10	MHz
t_{SU}	Set-up time: DATA to CLOCK, CLOCK to STROBE		30			ns
t_H	Hold time: CLOCK to DATA		30			ns
t_{SW}	Pulse width	CLOCK	30			ns
		STROBE (B - D words)	30			
		A word	$\frac{1}{f_{REF} \cdot N_{REF}} + t_w$			

1. Transmit mode @ 33% duty cycle.
2. The relative output current variation is defined thus:

$$\Delta I_{out}/I_{out} = 2x(I_2 - I_1)/(I_2 + I_1)$$
; with $V_1 = 0.7V$, $V_2 = V_{CC} - 0.8V$ (see figure 3)
3. Power supply current measured with $f_{RX} = 2100.54\text{ MHz}$, $f_{REF} = 19.44\text{ MHz}$, $f_{INA} = 109.92\text{ MHz}$, main phase detector bias resistor = 7.5 kΩ. Main phase detector reference frequency = 240 kHz, auxiliary phase detector frequency = 240 kHz.
4. Maximum and minimum levels guaranteed by design and random testing for temperature range of -40 to +85°C.
5. Power is rated at I/Q input level of 0.9V_{PP}.

900 MHz transmit modulator and 1.3 GHz fractional-N synthesizer

SA9024

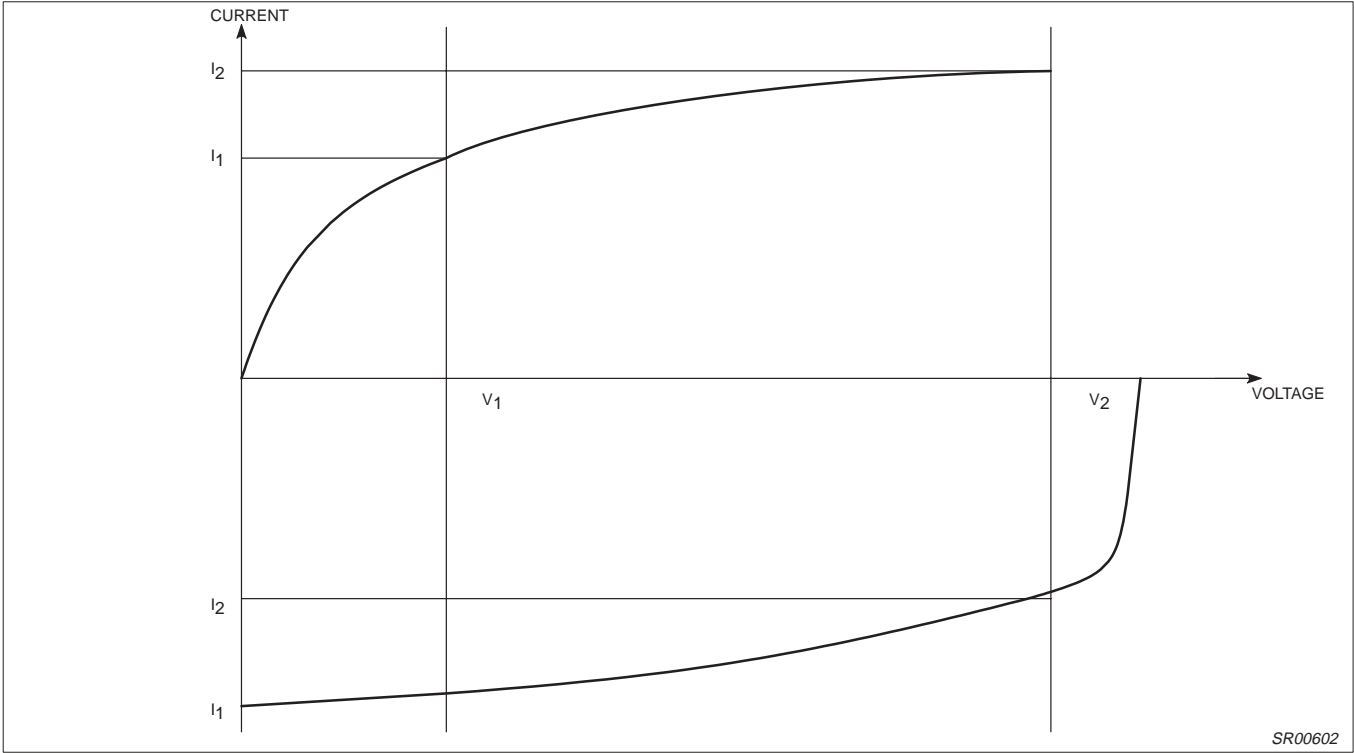

Figure 3. Output Current Definition

900 MHz transmit modulator and 1.3 GHz fractional-N synthesizer

SA9024

Functional Description Main Channel Synthesizer & Auxiliary Synthesizer

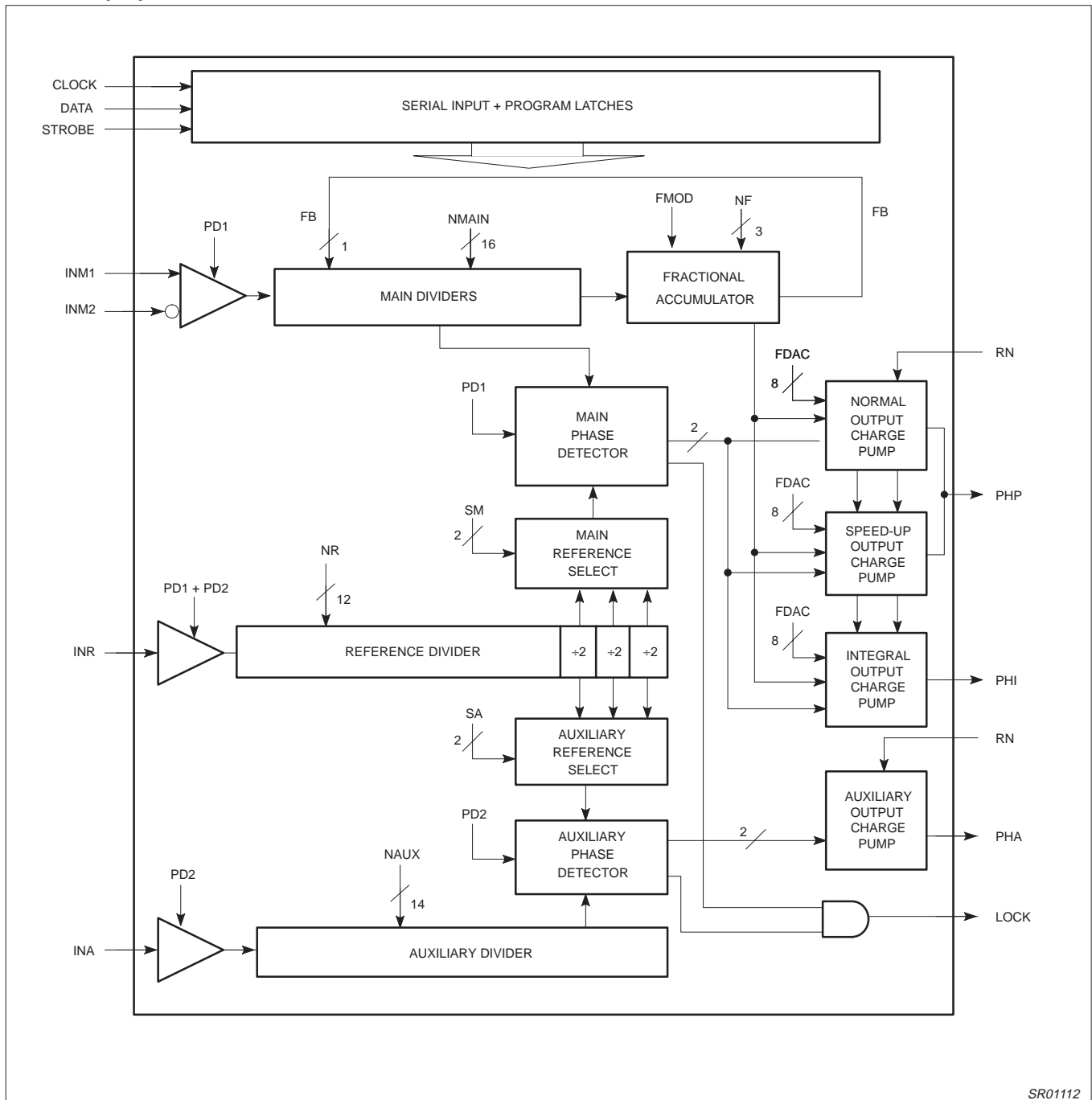

Figure 4. Synthesizer Block Diagram

SR01112

Serial Programming Input

The serial input is a 3-wire input (CLOCK, DATA, STROBE) used to program all counter ratios, DACs, selection and enable bits. The programming data is structured into 24-bit words; each word includes 2 or 3 address bits. Figure [5] shows the timing diagram of the serial input. When STROBE = L, the clock driver is enabled and on positive edges of the CLOCK, the signal on DATA input is

clocked into a shift register. When STROBE = H, the clock is disabled and the data in the shift register remains stable.

Depending on the 2 or 3 address bits, data is latched into different working or temporary registers. In order to fully program the synthesizer, 3 words must be sent: A, B and C. The D word programs all other functions within the SA9024. Those functions are

900 MHz transmit modulator and 1.3 GHz fractional-N synthesizer

SA9024

power control, +M (offset loop), SE (Tx offset loop synthesizer enable), DUAL mode, Sleep Mode 1 and Sleep Mode 2.

The data for FDAC is stored by the B word into a temporary register. When the A word is loaded, the data in this temporary register is loaded together with the A word into the work registers to avoid false temporary main synthesizer output caused by changes in fractional compensation.

The A word contains new data for the main divider. The A word is loaded into the working registers only when a main divider synchronization signal is active to avoid phase jumps when

reprogramming the main divider. The synchronization pulse is generated by the main divider when it has reached its terminal count, at which time a main divider output pulse is also sent to the main phase detector. This disables the loading of the A word each main divider cycle during maximum of (N_{REF} / f_{REF}) seconds. Therefore, to be sure that the A word will be correctly loaded, the STROBE signal must be high for at least (N_{REF} / f_{REF}) seconds. When programming the A word, the main charge pumps on output PHP and PHI are set into the speed-up mode as soon as the A word is latched into the working registers and remain so as long as STROBE is held high.

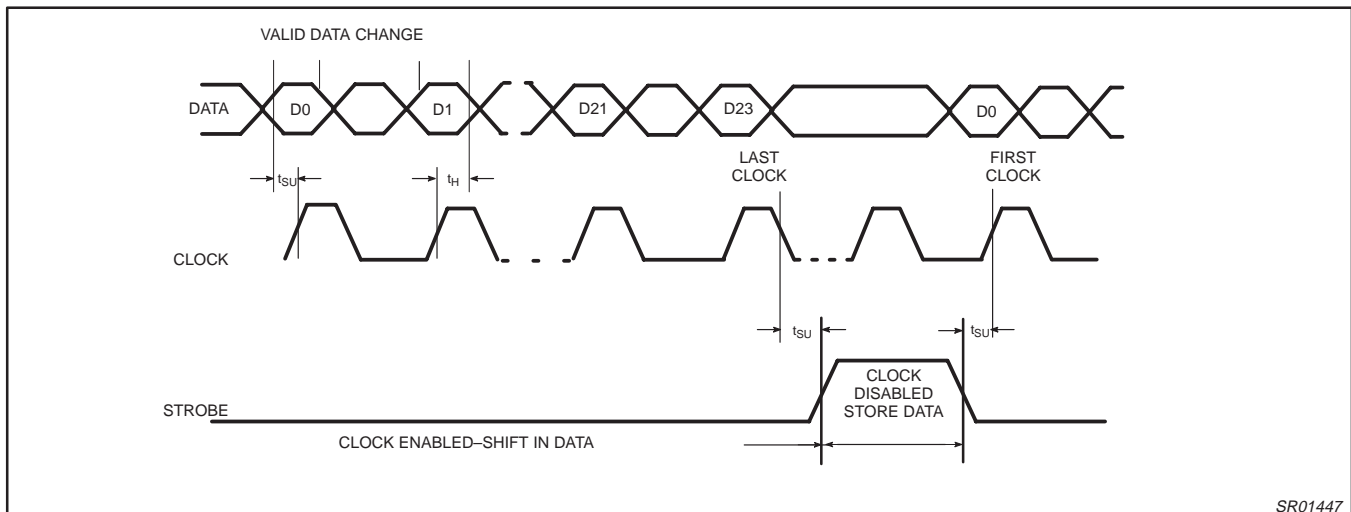

Figure 5. Serial Input Timing Sequence

SR01447

900 MHz transmit modulator and 1.3 GHz fractional-N synthesizer

SA9024

Table 1. Function Table

Symbol	Bits	Function
FMOD	1	Fractional-N modulus selection flag: '0' = modulo 8 '1' = modulo 5
NF	3	Fractional-N increment
NMAIN	16	Main divider ratio; 512 to 65,535 allowed
NREF	10	Reference divider ratio; 4 to 1,023 allowed, RSM, RSA = "0 0"
RSM	2	Reference select for main phase detector
RSA	2	Reference select for auxiliary phase detector
FDAC	8	Fractional compensation charge pump current DAC
NAUX	14	Auxiliary divider ratio; 128 to 16,384 allowed
CP	2	Charge pump current ratio select (see table 1)
LD	2	Lock detect output select (see table 2)
PD1	1	PD1 = 0 for power down; shuts off power to main divider and main chargepumps, anded with PD2 to turn off ref. divider.
PD2	1	PD2 = 0 for power down; shuts off power to auxiliary divider, and auxiliary charge pumps; anded with PD1 to turn off ref. divider.
PC	8	Power control (see note 3)
M	2	$\pm M$, M = 6, 7, 8, 9 (see note 4)
SE	1	Transmit offset synthesizer on/off
TM	1	Transmit mode: '0' = DUAL
AD	1	Mode control, 1 = digital; 0 = analog
SM1	1	Sleep mode 1
SM2	1	Sleep mode 2

1. Data bits are shifted in on the the leading clock edge, with the least significant bit (LSB) first and the most significant bit (MSB) last.

2. On the rising edge of the strobe and with the address decoder output = 1, the contents of the input shift register are transferred to the working registers. The strobe rising edge comes one half clock period after the clock edge on which the MSB of a word is shifted in.
3. The PC bits are used for the power control function. Eight (8) bits of data allows for appropriate resolution of the power control. 00000000 = 0 dB; 11111111 = -45.9 dB (= 255 \times 0.18).
4. The M bits are used to program the $\pm M$ counter for integer values between 6 and 9. 00 = 6, 01 = 7, 10 = 8, 11 = 9.
5. The TM bit is used to put the SA9024 into DUAL mode operation. In DUAL mode (TM = 0).
6. The AD bit allows a reduction in the linearity of the DUAL output driver while in AMPS mode.
7. The SM1 bit is used to shut down the TX_{LO} buffers. SM1 = 1, buffers on; SM1 = 0, buffers off.
8. The SM2 bit is used to shut down the RCLK buffer. SM2 = 1, buffer on; SM2 = 0, buffer off.
9. The SE bit turns on and off the offset loop synthesizer circuits. SE = 1, synthesizer on; SE = 0, synthesizer off.
10. The LOCK bits determine what signal is present on the LOCK pin as follows:

Table 2.

Lock Detect Output Select*	
LOCK	LOCK Pin Function
00	Main, auxiliary and offset lock condition
01	Main and auxiliary lock condition
10	Main lock detect condition
11	Auxiliary lock condition

*When a section is in power down mode, the lock indicator for that section is high.

900 MHz transmit modulator and 1.3 GHz fractional-N synthesizer

SA9024

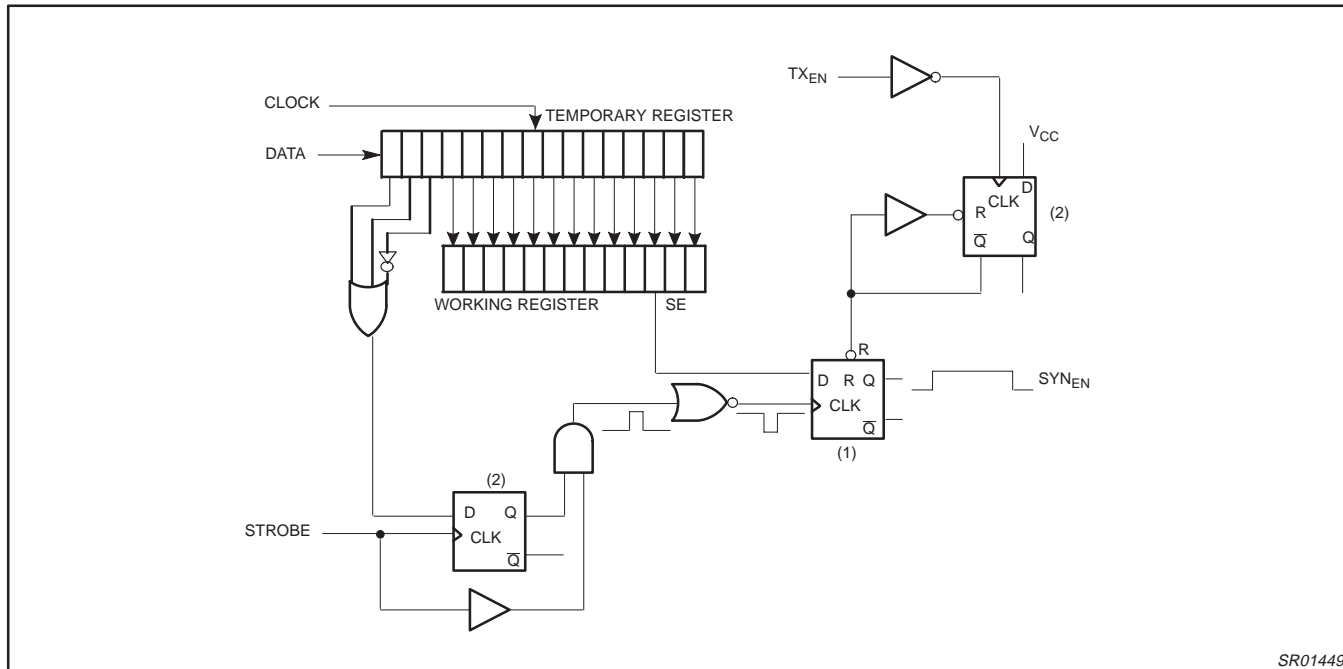

Figure 6. Transmit Offset Synthesizer Reset Circuit

In Figure 6, the falling edge of the strobe and address, inverted, toggles the Q output of flip-flop (1) to a '1' state, enabling the phase detector, VCO, divide by M, TX_{IF} buffer and SSB up-converter. Approximately 80µs after the synthesizer is locked, the TX_{EN} signal (enabled = 1) turns on the modulator and variable gain amplifier. The rising edge of TX_{EN} has no effect on SYN_{EN}, however, the falling (rising inverted) edge toggles the Q̄ output of D flip-flop (2) to a '0' state. This disables the synthesizer, modulator and variable gain amplifier. To insure that slow edges on TX_{EN} do not cause improper operation, the TX_{EN} is a Schmitt trigger design.

The address decoder for program word 'D' ANDed together with the strobe is used to load the contents of the temporary register into the working registers. D flip-flop (3) is used to prevent multiple strobe and address pulses in the event the address decoder output toggles on garbage bits during the time the strobe remains in a '1' state.

The temporary register is common to the transmit offset synthesizer, main channel synthesizer and auxiliary synthesizer.

900 MHz transmit modulator and 1.3 GHz fractional-N synthesizer

SA9024

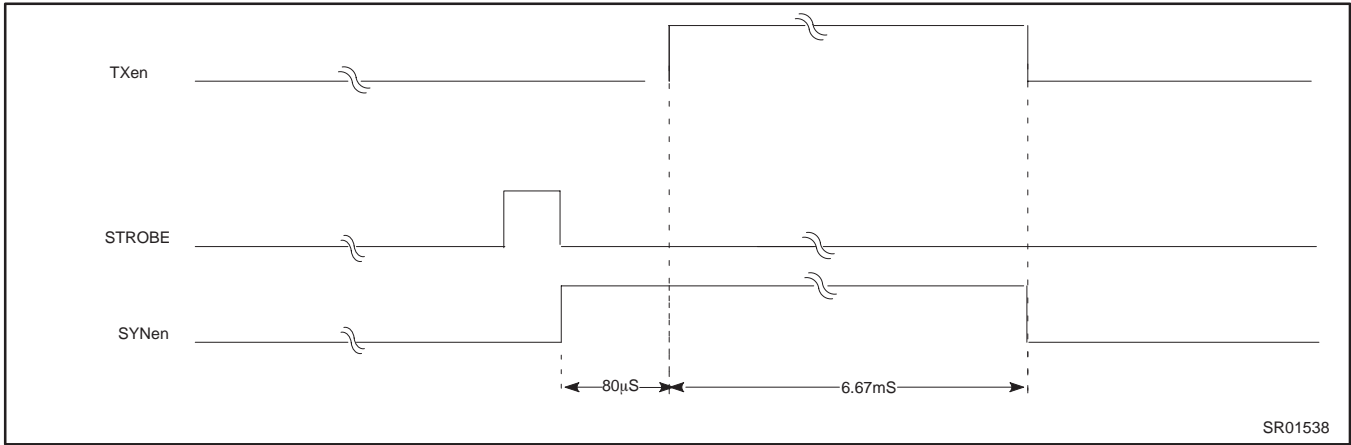

Figure 7. Transmit Offset Synthesizer Timing Diagram

SR01538

900 MHz transmit modulator and 1.3 GHz fractional-N synthesizer

SA9024

Data format

Format of programmed data

LAST IN				MSB		SERIAL PROGRAMMING FORMAT						FIRST IN LSB	
p23		p22		p21		p20	../..	../..			p1		p0

A word, length 24 bits

Last in				MSB																LSB		First IN		
Address		fmod		Fractional-N			Main Divider ratio- Nmain																Spare	
0	1	Fmod	NF2	NF1	NF0	N15	N14	N13	N12	N11	N10	N9	N8	N7	N6	N5	N4	N3	N2	N1	N0	sk1	sk2	
Default:	0	0	1	0	0	0	0	1	0	0	0	1	0	0	0	1	1	0	0	0	0	0	0	
A word select		Fixed to 00.																						
Fractional Modulus select		FM 0=modulo 8, 1=modulo 5.																						
Fractional-N Increment		NF2..0 Fractional N Increment values 000 to 111.																						
N-Divider		N0..N15, Main divider values 512 to 65535 allowed for divider ratio.																						

B word, length 24 bits

ADDRESS		REFERENCE DIVIDER NREF										RSM		RSA		FRACTIONAL COMPENSATION DAC							
0	1	R9	R8	R7	R6	R5	R4	R3	R2	R1	R0	RSM 1	RSM 0	RSA 1	RSA 0	Fdac 7	Fdac 6	Fdac 5	Fdac 4	Fdac 3	Fdac 2	Fdac 1	Fdac 0
Default:	0	0	0	0	1	0	1	0	0	0	1	0	0	0	0	x	x	x	x	x	x	x	x
B word select		Fixed to 01																					
R-Divider		R0..R9, Reference divider values 4 to 1023 allowed for divider ration.																					
Charge pump current Ratio		CP1, CP0: Charge pump current ratio, see table of charge pump currents.																					
Main comparison select		RSM Comparison divider select for main phase detector.																					
Aux comparison select		RSA Comparison divider select for auxiliary phase detector.																					
Fractional Compensation		Fdac7..0, Fractional compensation charge pump current DAC, values 0 to 255. FDAC = 77 for best op MOD8.																					

C word, length 24 bits

ADDRESS		AUXILIARY DIVIDER NAUX														CP		LOCK		PD		SPARE	
1	0	A13	A12	A11	A10	A9	A8	A7	A6	A5	A4	A3	A2	A1	A0	CP1	CP0	LD1	LD0	PD1	PD2	PD3	LOD
Default	0	0	0	0	0	0	1	1	1	0	0	1	0	1	0	1	1	0	0	TXEN	TXEN	0	0
C word select		Fixed to 10																					
A-Divider		A0..A13, Auxiliary divider values 128 to 16384 allowed for divider ratio.																					
Charge pump current Ratio		CP1, CP0: Charge pump current ratio, see table fo charge pump currents.																					
Lock detect output		LD1 LD0 0 0 Combined main, aux. & offset loop lock detect signal present at the LOCK pin. 0 1 Combined main and aux. lock detect signal present at the LOCK pin. 1 0 Main lock detect signal present at the LOCK pin. 1 1 Auxiliary loop lock detect signal present at the LOCK pin. When a section is in power down mode, the lock indicator for that section is high.																					
Power down		PD1=1: power to N-divider, reference divider, main charge pumps, PD1=0 to power down. PD2=1: power to Aux divider, reference divider, Aux charge pumps, PD2=0 to power down.																					

900 MHz transmit modulator and 1.3 GHz fractional-N synthesizer

SA9024

Table 3.
Main and auxiliary chargepump currents

CP1	CP0	I _{PHA}	I _{PHP}	I _{PHP-SU}	I _{PHI-SU}
0	0	1.5xlset	3xlset	15xlset	36xlset
0	1	0.5xlset	1xlset	5xlset	12xlset
1	0	1.5xlset	3xlset	15xlset	0
1	1	0.5xlset	1xlset	5xlset	0

NOTES

1. I_{SET} = Vset/RN; bias current for charge pumps.
2. CP1 is used to disable the PHI pump.
3. I_{php_su} is the total current out of PHP in speedup mode.

D word, length 24 bits

Address			Power Control								M divider		SE	TM	AD	Sleep Mode		Test pa_current							
1	1	0	PC7	PC6	PC5	PC4	PC3	PC2	PC1	PC0	M1	M0	SE	TM	AD	SM1	SM2	pai5	pai4	pai3	pai2	pai1	pai0		
Default:			x	x	x	x	x	x	x	x	0	0	0	0	0	0	0	0	0	0	0	0	0	0	
D0 word select			Fixed to 110.																						
Output Power Control			PC7(msb)...PC0(lsb) Provides output power attenuation for DUAL mode amplifier outputs in 0.18 dB steps, Fx = 45.9 dB.																						
M Divider			00 = 6, 01 = 7, 10 = 8, 11 = 9																						
Offset loop power down			SE Offset loop synthesizer power down, SE = 1 power on, SE = 0 power down (sleep mode).																						
DUAL mode select			TM = 0 DUALmode																						
AMPS/DAMPS mode select			AD = 1 DAMPS mode. AD = 0 AMPS mode																						
TX buffers power down			SM1 TX Local oscillator buffers power down. SM1 = 1 power on, SM1 = 0 to power down. SM2 RCLK buffer power down. SM2 = 1 power on, SM2 = 0 to power down.																						
Test: pa_current:pai			TX test bits for controlling the current in the power amp. Should be 0 during normal operation.																						

900 MHz transmit modulator and 1.3 GHz fractional-N synthesizer

SA9024

MODES OF OPERATION

There are two power saving modes of operation which the circuit can be put into, dependent on the status of the system. The intention of these different modes is to disable circuitry that is not in use at the time in order to reduce power consumption. During sleep mode, only circuitry which is required to provide a master clock to

the digital portion of the system is enabled. During receive mode, circuitry which is used to perform the receive function and provide a master clock is enabled. In transmit mode all the functions of the circuit are enabled which are required to perform transmit, receive and provide master clock. When the circuit is powered for the first time, it is in DUAL MODE SLEEP.

Mode Programming

Mode	Dual Mode AMPS			Logic
	Sleep	RX	TX	
Mode Setting and BlockStatus (X = ON)				
TX _{EN}	0	0	1	
PD1	0	1	1	
PD2	0	1	1	
SE→SYN _{EN}	0	0	1	
TM	0	0	0	
SM1	0	0	1	
SM2	0	1	1	
Main loop, Ndivider, RXLO buffer		X	X	PD1
Aux loop, Adivider		X	X	PD2
Rdivider		X	X	PD1 .OR. PD2
Offset VCO, Mdivider			X	SE (+delay) See SE→SYN _{EN} diagram
RCL buffer		X	X	SM2
MCL buffer, reference input	X	X	X	1 (always ON)
DUAL _{TX} PA			X	(.not. TM) .and. TX _{EN} .and. SM1
TXLO buffer, SSB up-converter			X	SM1
I/Q MODULATOR, VGA			X	TXEN .AND. SM1
Control Logic	X	X	X	1 (always ON)

Main Divider

The input signal on RX_{LO} is amplified to a logic level by a balanced input comparator giving a common mode rejection. This input stage is enabled by serial control bit PD1 = 1. Disabling means that all currents in the comparator are switched off. The main divider is built up to be a 16-bit counter.

The loading of the work registers F_{MOD}, N_F and N_{MAIN} is synchronized with the state of the main counter to avoid extra phase disturbance when switching over to another main divider ratio as is explained in the Serial Programming Input chapter.

At the completion of a main divider cycle, a main divider output pulse is generated which will drive the main phase comparator. Also, the fractional accumulator is incremented with N_F. The accumulator works modulo Q. Q is preset by the serial control bit F_{MOD} to 8 when F_{MOD} = '0'. Each time the accumulator overflows, the total divide ratio will be N_{MAIN} + 1 for the next cycle. The mean division ratio over Q main divider cycles will then be:

$$NQ = N_{MAIN} + \frac{N_F}{Q}$$

Synchronization is provided to avoid a random phase on the phase detector upon the loading of a new ratio and when powering up the loop.

Auxiliary Divider

The input signal on INA is amplified to logic level by a single-ended input buffer, which accepts low level AC-coupled input signals. This input stage is enabled if the serial control bit PD2 = '1'. Disabling means that all currents in the buffer and prescaler are switched off. The auxiliary divider is programmed with 14 bits and has continuous integer division ratios over the range of 128 to 16,384.

Reference Divider (Figure 8)

The input can be driven by a differential crystal input or an external TCXO. This input stage is enabled by the OR function of the serial input bits PD1 and PD2. Disabling means that all currents are switched off. The reference divider consists of a programmable divide by N_{REF} (N_{REF} = 4 to 1,023) followed by a 3-bit binary counter. The 2 bit SM determines which of the four output pulses is selected as the main phase detector signal. To obtain the best time spacing for the main and auxiliary reference signals, a different output will be used for the auxiliary phase detector, reducing the possibility of unwanted interactions.

900 MHz transmit modulator and 1.3 GHz fractional-N synthesizer

SA9024

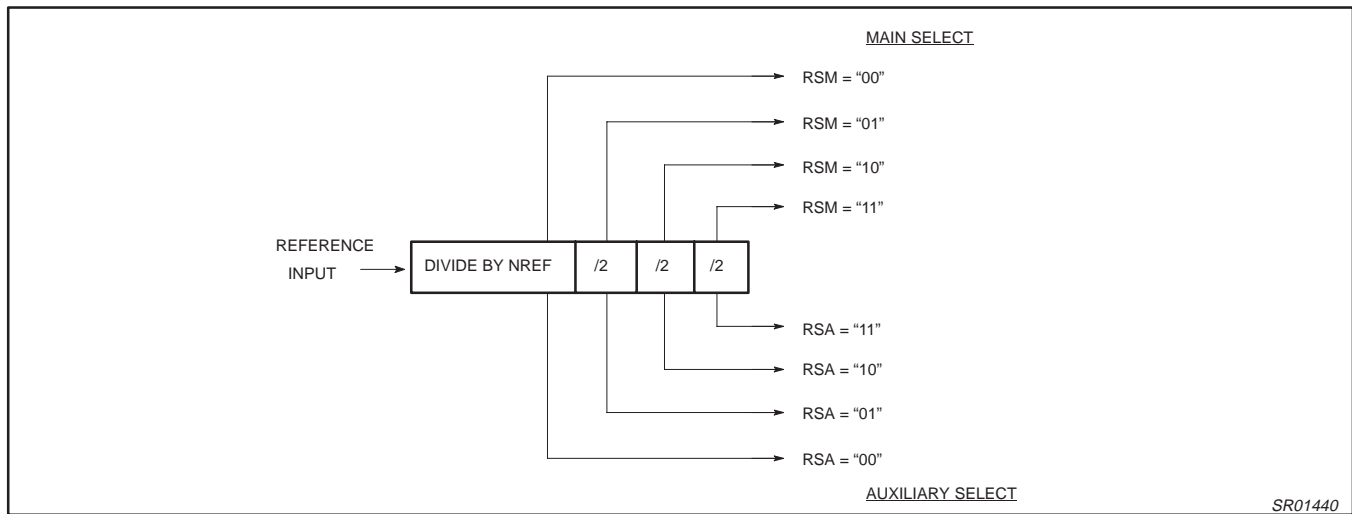

Figure 8. Reference Variable Divider

Phase Detectors (Figure 9)

The auxiliary and main phase detectors each consist of a 2 D-type flip-flop phase and frequency detector. Each flip-flop is set by the negative edge of the divider terminal count output pulse. The reset inputs are activated after a delay when both flip-flops have been set. This avoids non-linearity or dead-band around zero phase error. The flip-flops drive on-chip charge pumps. A pull-up current from the charge pump indicates the VCO frequency shall be increased while a pull-down pulse indicates the VCO frequency shall be decreased.

Current Settings

The IC has two current setting pins, RN and I_{PEAK}. The active charge pump currents and the fractional compensation currents are linearly dependent on the current in the current setting pins. This current, I_{SET}, is set by an external resistor connected between the current setting pin and V_{SS}.

Auxiliary Output Charge Pumps

The auxiliary charge pumps on pin PHA are driven by the auxiliary phase detector and the current value is determined by the external resistor attached to pin RN.

900 MHz transmit modulator and 1.3 GHz fractional-N synthesizer

SA9024

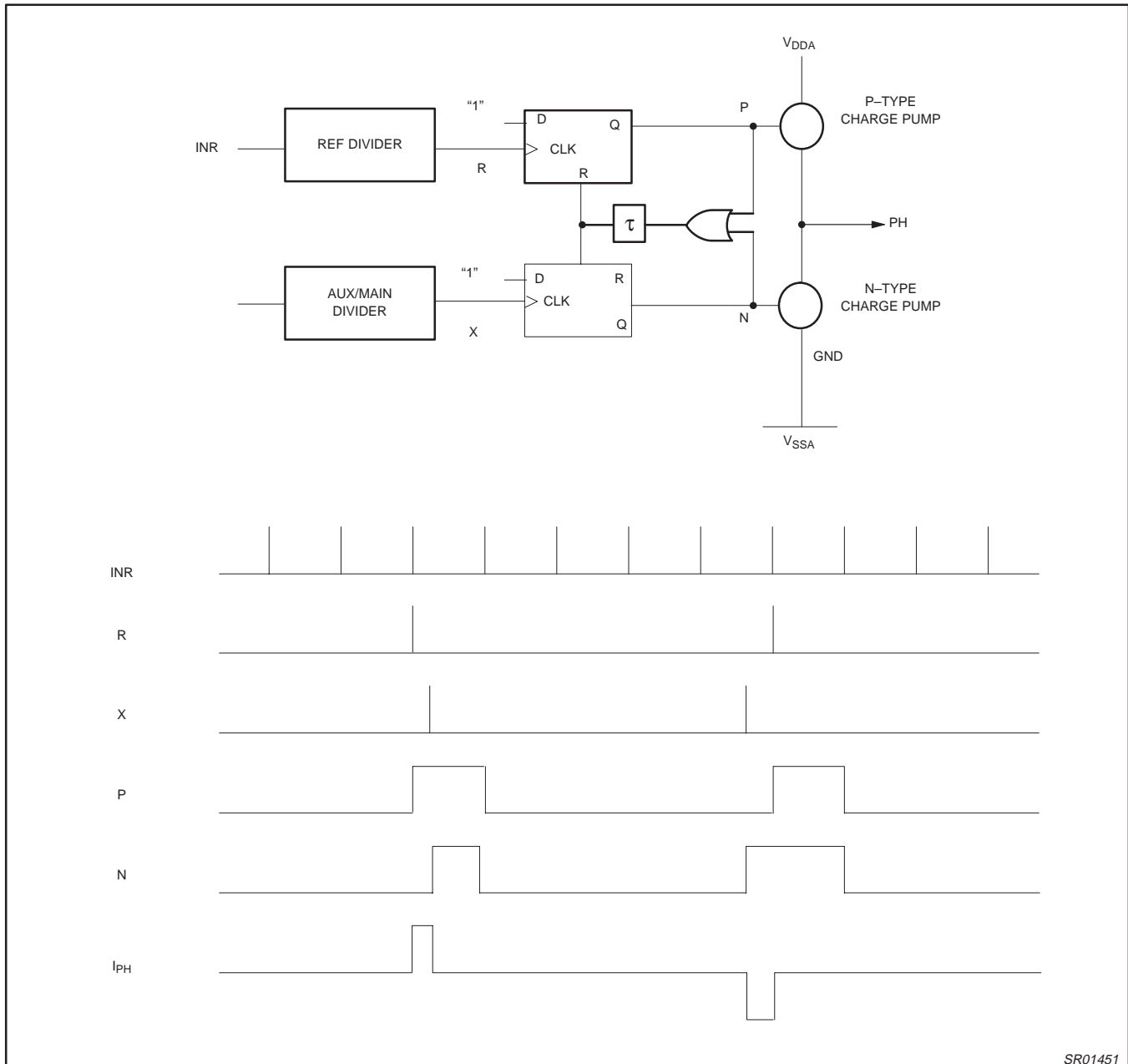

Figure 9. Phase Detector Structure With Timing

Main Output Charge Pumps and Fractional Compensation Currents

The main charge pumps on pin PHP and PHI are driven by the main phase detector. The current value is determined by the current at pin RN. The fractional compensation current is linearly dependent

on the main charge pump current and its level relative to the main charge pumps is set by an 8-bit programmable DAC. The timing for the fractional compensation is derived from the main divider. The current level based on the value of FRD, FDAC and I_{SET}. Figure 10 shows the waveforms (not to scale) for a typical base.

900 MHz transmit modulator and 1.3 GHz fractional-N synthesizer

SA9024

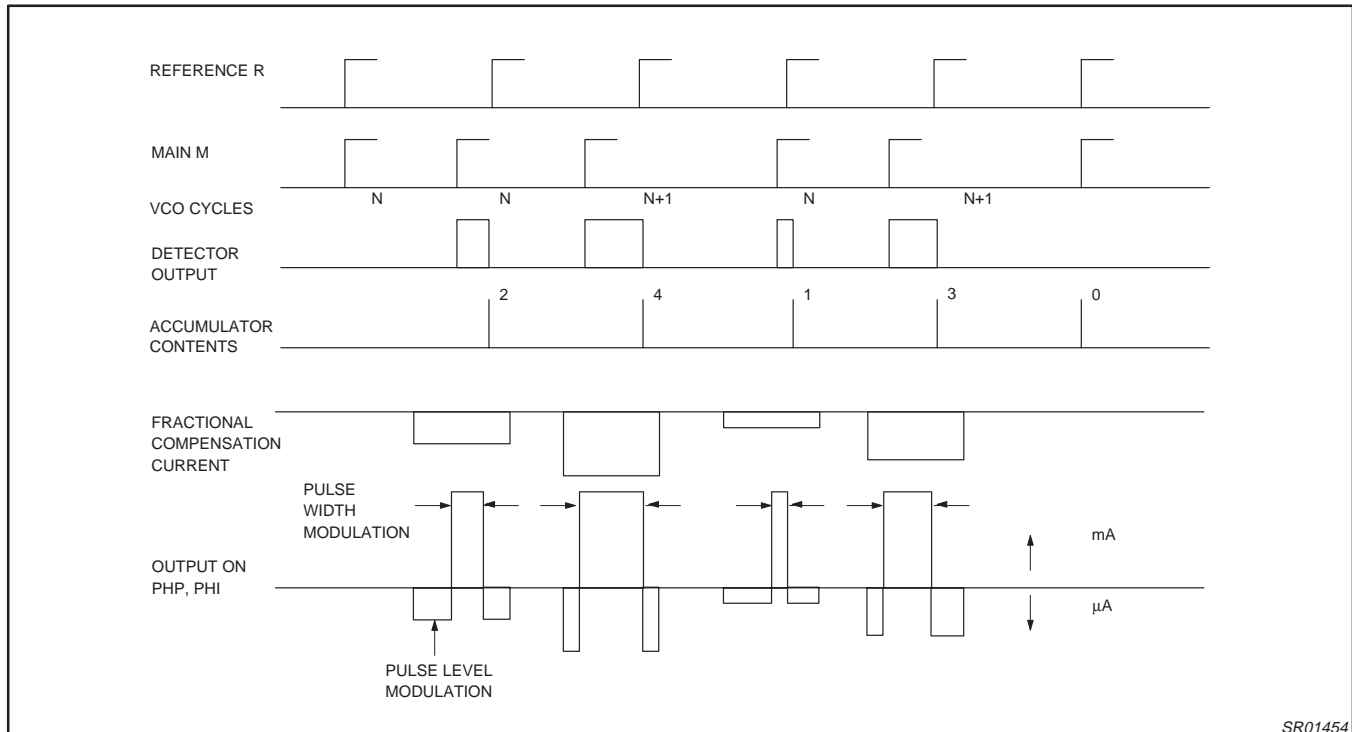

Figure 10. Waveforms for NF = 2; Fraction = 0.4

Figure 10 shows that for a proper fractional compensation, the area of the fractional compensation current pulse must be equal to the area of the charge pump ripple output.

The fractional compensation current is derived from the main charge pump in that it will follow all the current scaling through external resistor setting, programming or speedup operation.

For a given pump,

$$I_{comp} = \frac{I_{pump}}{128} \times \frac{F_{dac}}{5 \times 128} \times FRD$$

Where:

I_{comp} is the compensation current, I_{pump} is the pump current, F_{dac} is the fractional DAC value and FRD is the fractional accumulator value.

The theoretical value for F_{dac} would then be: 128 for $F_{mod} = 1$ (modulo 5) and 80 for $F_{mod} = 0$ (modulo 8).

When the serial input A word is loaded, the output circuits are in the “speedup mode” as long as the STROBE is H, otherwise the “normal mode” is active.

Lock Detect

The output LOCK maintains a logic ‘1’ when the auxiliary phase detector ANDed with the main phase detector ANDed with Offset Phase Detector indicates a lock condition. During the Standby mode of operation when the offset loop is unlocked, ($SYN_{EN} = low$ – see figure 6), the offset phase detector lock output is forced to an on (locked) state so that the lock detect will give an indication of receiver lock. The lock condition for the main and auxiliary synthesizers is defined as a phase difference of less than ± 1 cycle on the reference input INR. The LOCK condition is also fulfilled

when the relative counter is disabled ($PD1 = '0'$ or $PD2 = '0'$) for the main or auxiliary counter, respectively.

Functional Description of Offset Loop, Modulator and Power Control

Transmit Offset Synthesizer

The transmit offset phase locked loop portion of the SA9024 design consists of the following functional blocks: reference oscillator, limiters, phase detector, +M, IF VCO and passive loop filter. Harmonic contents of this signal are attenuated by an LP filter. The output of the IF VCO is also divided by N and compared with the reference oscillator in the phase detector.

Reference Oscillator

This Oscillator is used to generate the reference frequency together with an external crystal and varicap. The output is internally routed to three buffers and a phase comparator. It is possible to run the oscillator as an amplifier from an external reference signal (TCXO).

Phase Detector and Charge Pump

The phase comparator is used to compare the output of the divider with the reference. It provides an output proportional to the phase difference between the divided down VCO and the reference. This output is then filtered and used as the control voltage input to the VCO. The phase detector is a Gilbert multiplier cell type, having a linear output from 0 to π ($\pi/2 \pm \pi/2$), followed by a charge pump. The charge pump peak output current is programmable to 6.4mA via the use of an external resistor.

A preliminary design analysis has been performed with the following loop parameters:

900 MHz transmit modulator and 1.3 GHz fractional-N synthesizer

SA9024

A lock detect signal is provided and ANDed together with lock detect signals from both the main channel synthesizer and auxiliary synthesizer. While in standby mode, the lock detect signal will be forced to a valid lock state so that the lock detect signal will indicate when the main and auxiliary phase detectors have achieved phase lock.

Divide by M

The ÷M is a 2-bit programmable divider which can be configured for any integer divide from 6 to 9. The divider is used to convert the VCO output down to the reference frequency before feeding it into the phase comparator.

VCO

This oscillator is used to generate the transmit IF frequency between 90MHz and 180MHz. The VCO tank is configured using a parallel inductor tuning varactor diode. DC blocking capacitors are used to isolate the varactor control voltage from the VCO tank DC bias voltages.

SSB Up-converter and TX_{IF} Buffer

The TX_{IF} buffer provides isolation between the SSB Up-converter and the VCO output. The Single Sideband Up-converter (SSB) is an active Gilbert cell multiplier (matched pair), combined with two

quadrature phase shift networks and a low pass filter. The SSB up-converter is used to reject the unwanted upper sideband that would normally occur during the up-conversion process.

I/Q Modulator

The quadrature modulator is an active Gilbert cell multiplier (matched pair) with cross coupled outputs. These outputs are then provided to the variable gain amplifier. When the in-phase input $I = \cos(\omega t)$ and the quadrature-phase input $Q = \sin(\omega t)$ (i.e., Q lags I by 90°), the resulting output should be upper single sideband.

Variable Gain Amplifiers

The variable gain amplifiers are used to control the output level of the device, with a power control range of 45.9dB. The output stages are differential, matched from 200Ω to 50Ω.

Power Control

The power control range should be greater than or equal to 45.9dB, having a monotonically decreasing slope, with 0dB = +11.5 dBm nominal. Eight bits are available for power control programming. The top 6 bits (PC7 to PC2) provide coarse attenuation with .6dB step size accuracy. The bottom 2 bits provide fine attenuation with .18 dB step size accuracy.

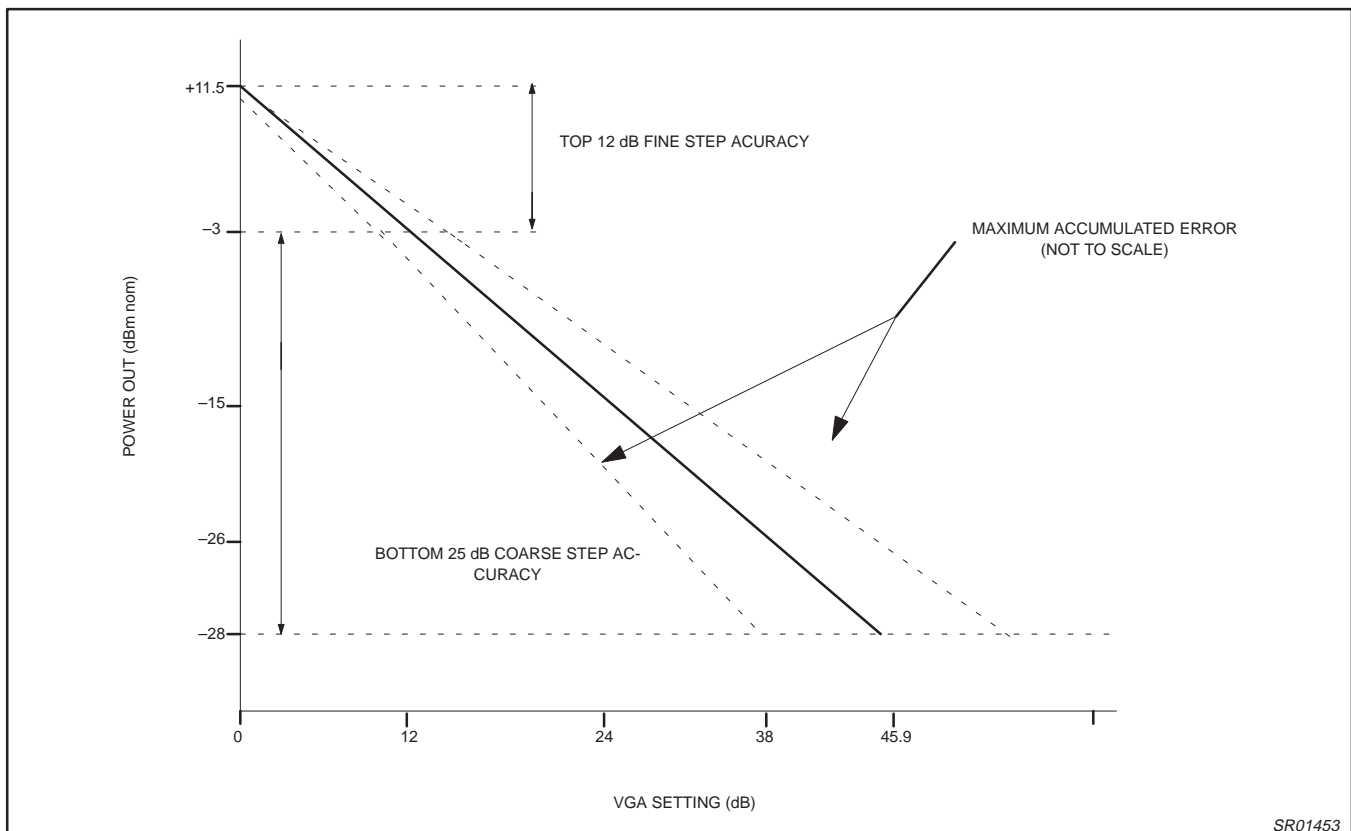

Figure 11. Power Control

Oscillator Buffers

There are three buffers for the reference signal, two of which are used to provide external reference signals. The internal reference signal is used for the main and auxiliary synthesizer reference. The second buffer (MCLK) is used as a master clock for external digital

circuitry which is always on, while the third buffer (RCLK) is used as a clock for external digital circuitry which is not used in sleep mode.

LO Buffers

The LO buffers are used to provide isolation for the VCO and between the transmitter up-converter and channel synthesizer.

900 MHz transmit modulator and 1.3 GHz fractional-N synthesizer

SA9024

LQFP48: plastic low profile quad flat package; 48 leads; body 7 x 7 x 1.4 mm

SOT313-2

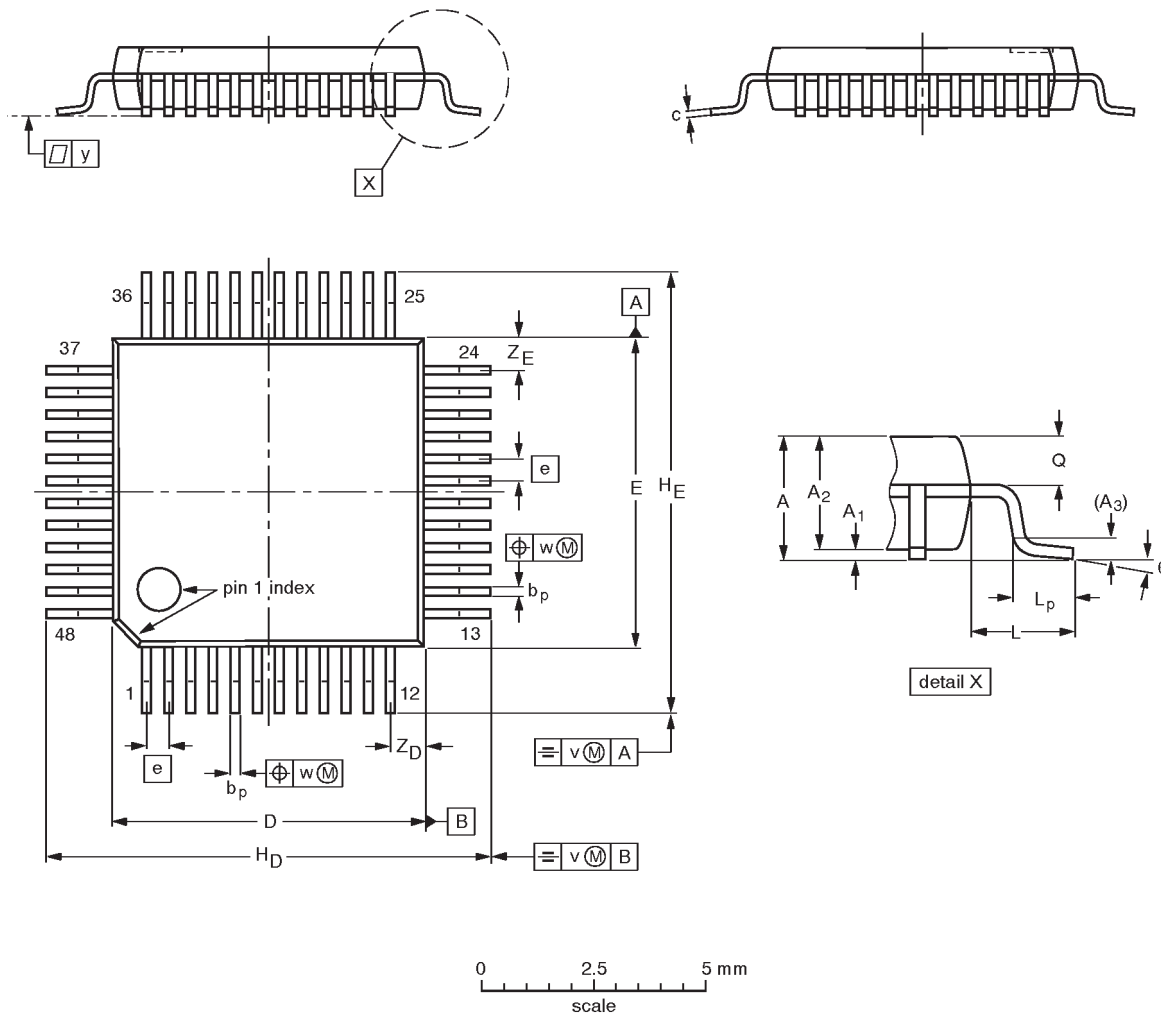

DIMENSIONS (mm are the original dimensions)

UNIT	A max.	A ₁	A ₂	A ₃	b _p	c	D ⁽¹⁾	E ⁽¹⁾	e	H _D	H _E	L	L _p	Q	v	w	y	Z _D ⁽¹⁾	Z _E ⁽¹⁾	θ
mm	1.60	0.20 0.05	1.45 1.35	0.25	0.27 0.17	0.18 0.12	7.1 6.9	7.1 6.9	0.5	9.15 8.85	9.15 8.85	1.0	0.75 0.45	0.69 0.59	0.2	0.12	0.1	0.95 0.55	0.95 0.55	7° 0°

Note

1. Plastic or metal protrusions of 0.25 mm maximum per side are not included.

OUTLINE VERSION	REFERENCES				EUROPEAN PROJECTION	ISSUE DATE
	IEC	JEDEC	EIAJ			
SOT313-2						93-06-15- 94-12-19

900 MHz transmit modulator and 1.3 GHz fractional-N synthesizer

SA9024

DEFINITIONS

Data Sheet Identification	Product Status	Definition
<i>Objective Specification</i>	Formative or in Design	This data sheet contains the design target or goal specifications for product development. Specifications may change in any manner without notice.
<i>Preliminary Specification</i>	Preproduction Product	This data sheet contains preliminary data, and supplementary data will be published at a later date. Philips Semiconductors reserves the right to make changes at any time without notice in order to improve design and supply the best possible product.
<i>Product Specification</i>	Full Production	This data sheet contains Final Specifications. Philips Semiconductors reserves the right to make changes at any time without notice, in order to improve design and supply the best possible product.

Philips Semiconductors and Philips Electronics North America Corporation reserve the right to make changes, without notice, in the products, including circuits, standard cells, and/or software, described or contained herein in order to improve design and/or performance. Philips Semiconductors assumes no responsibility or liability for the use of any of these products, conveys no license or title under any patent, copyright, or mask work right to these products, and makes no representations or warranties that these products are free from patent, copyright, or mask work right infringement, unless otherwise specified. Applications that are described herein for any of these products are for illustrative purposes only. Philips Semiconductors makes no representation or warranty that such applications will be suitable for the specified use without further testing or modification.

LIFE SUPPORT APPLICATIONS

Philips Semiconductors and Philips Electronics North America Corporation Products are not designed for use in life support appliances, devices, or systems where malfunction of a Philips Semiconductors and Philips Electronics North America Corporation Product can reasonably be expected to result in a personal injury. Philips Semiconductors and Philips Electronics North America Corporation customers using or selling Philips Semiconductors and Philips Electronics North America Corporation Products for use in such applications do so at their own risk and agree to fully indemnify Philips Semiconductors and Philips Electronics North America Corporation for any damages resulting from such improper use or sale.

Philips Semiconductors
811 East Arques Avenue
P.O. Box 3409
Sunnyvale, California 94088-3409
Telephone 800-234-7381

Philips Semiconductors and Philips Electronics North America Corporation register eligible circuits under the Semiconductor Chip Protection Act.
 © Copyright Philips Electronics North America Corporation 1997
 All rights reserved. Printed in U.S.A.

print code

Date of release: 05-96

Document order number:

Let's make things better.