

FEATURES AND BENEFITS

- Low power loss, high efficiency operation
- Low forward voltage drop
- Fast switching capability
- High forward surge capability
- Excellent High Temperature Stability

MECHANICAL DATA

- Epoxy : UL94 V-0 rated flame retardant
- Case: TO-247 Package
- Terminals: Matte Tin annealed over copper
- Weight: Approximated 2.03 grams

Primary Characteristic	
I_O	2X40A
V_{RRM}	170V
I_{FSM}	880A
V_F Typical=5A, $T_J=125^\circ\text{C}$	0.43V
T_{Jmax}	175°C

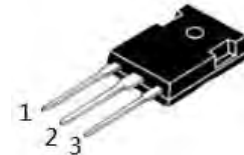

Maximum Ratings (TA=25°C unless otherwise specified)						
Characteristics		Symbol	Value	Unit		
Peak Repetitive Reverse Voltage		V_{RRM}	170	V		
Working Peak Reverse Voltage		V_{RWM}	170	V		
DC Blocking Voltage		V_{DC}	170	V		
RMS Reverse Voltage		V_{RMS}	119	V		
Average Forward Rectified Current (per diode)		I_O	40	Amps		
Peak Forward Surge Current, 8.3 ms Single Half Sine-wave Superimposed on Rated Load (JEDEC method)		I_{FSM}	880	Amps		
Electrical Characteristics (TA=25°C unless otherwise specified)						
Characteristics		Symbol	Typ.	Max.	Unit	
Forward Voltage Drop ⁽¹⁾	IF=5A Ta=25°C	V_F	0.58	0.62	V	
	IF=100A Ta=25°C	V_F	0.93	0.97	V	
	IF=5A Ta=125°C	V_F	0.43	0.47	V	
	IF=100A Ta=125°C	V_F	0.85	0.89	V	
Reverse Current ⁽²⁾	VR=170V Ta=25°C	I_R	3	9	μA	
	VR=170V Ta=125°C	I_R	5	15	mA	

THERMAL CHARACTERISTICS (TA = 25 °C unless otherwise noted)				
Characteristics		Symbol	Value	Unit
Typical Thermal Resistance, junction to case	TO-247	$R_{\theta JC}$	2	°C/W
Operating Temperature Range (in DC Mode)		T_J	-65 to +175	°C
Storage Temperature Range		T_{STG}	-65 to +150	°C

Notes (1): Pulse test: 300μs pulse width, 1% duty cycle.

Notes (2): Pulse width ≤40ms

Notes (3): FR-4 PCB, 2oz copper. Minimum recommended pad layout

RATINGS AND CHARACTERISTICS CURVES

Fig 1. Typical Forward Characteristics

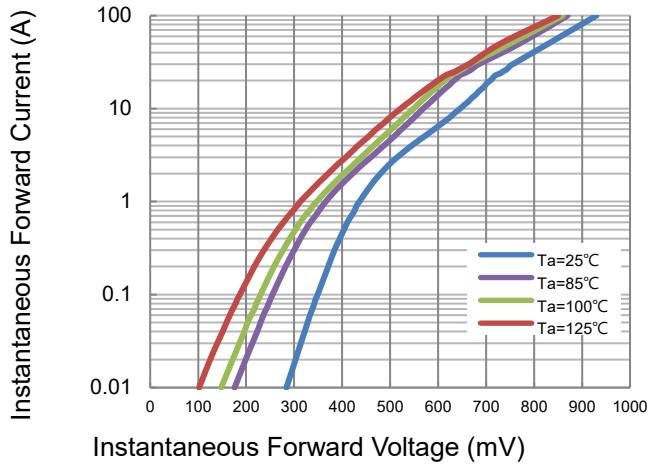

Fig 2. Typical Reverse Characteristics

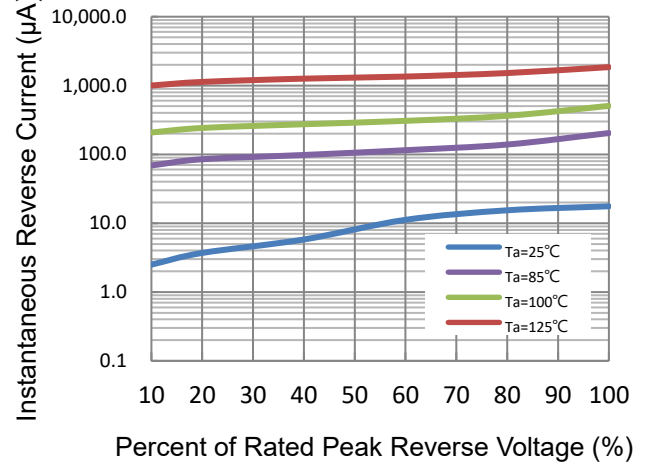

Fig 3. Typical Forward Current Derating Curve

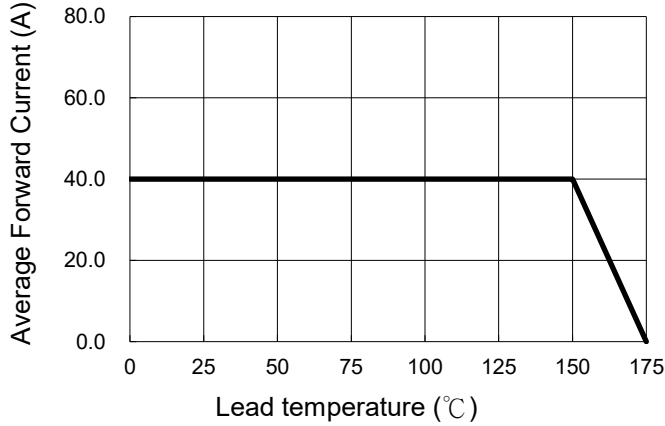
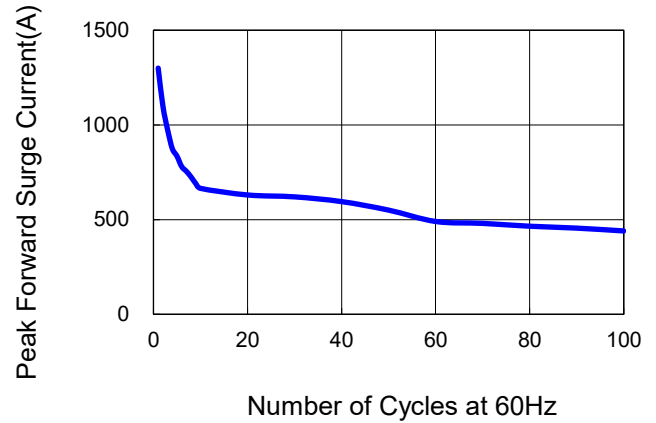
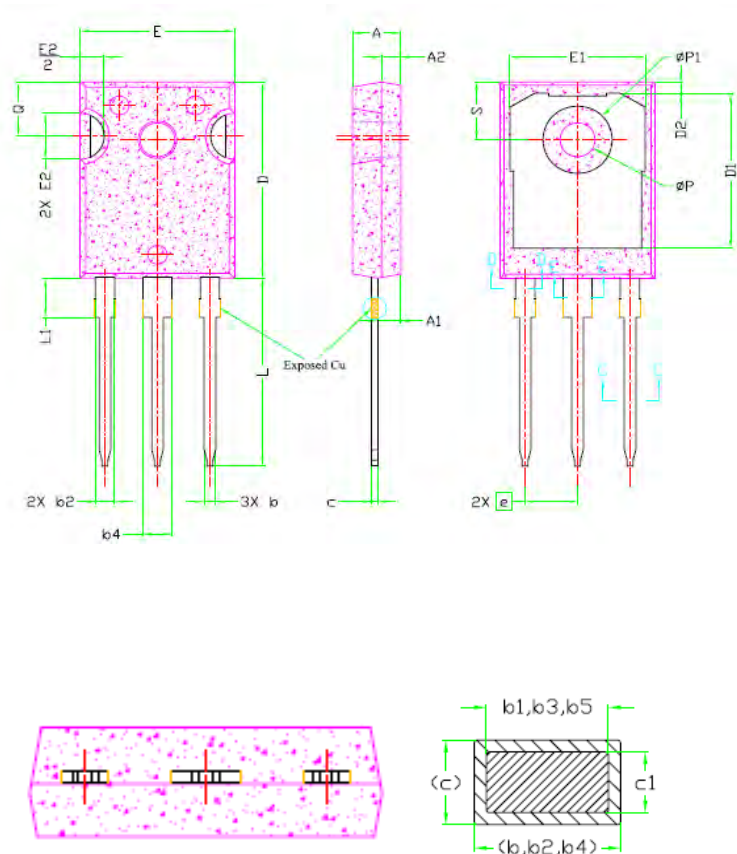

Fig 4. Non-repetitive Forward Surge Current



Package Outline Dimensions (in millimeters)

TO-247				
SYMBOL	Dimensions			
	Millimeters		Inches	
	Min	Max	Min	Max
A	4.83	5.21	0.19	0.21
A1	2.29	2.55	0.09	0.10
A2	1.50	2.49	0.06	0.10
b	1.12	1.33	0.04	0.05
b1	1.12	1.28	0.04	0.05
b2	1.91	2.39	0.08	0.09
b3	1.91	2.34	0.08	0.09
b4	2.87	3.22	0.11	0.13
b5	2.87	3.18	0.11	0.13
c	0.55	0.69	0.02	0.03
c1	0.55	0.65	0.02	0.03
D	20.80	21.10	0.82	0.83
D1	16.25	17.65	0.64	0.69
D2	0.51	1.35	0.02	0.05
E	15.75	16.13	0.62	0.64
E1	13.46	14.16	0.53	0.56
E2	4.32	5.49	0.17	0.22
e	5.44			
L	19.81	20.32	0.78	0.80
L1	4.10	4.40	0.16	0.17
ψP	3.56	3.65	0.14	0.14
ψp1	7.19REF			
Q	5.39	6.20	0.21	0.24
S	6.04	6.30	0.24	0.25



Shanghai Leiditech Electronic Co.,Ltd
 Email: sale1@leiditech.com
 Tel : +86- 021 50828806
 Fax : +86- 021 50477059