

6CH ELECTRIC VOLUME WITH TONE CONTROL

DESCRIPTION

The SC62446 is 6 channels electric volume controlled 3-wire serial data. The IC is suitable for use in home-use audio systems and TV sets.

FEATURES

- Electric volume
Volume level.....0dB~-79dB, -∞dB (1dB/step)
- Tone control
Bass/treble, 0dB ~ ±10dB (2dB/step)
- 4 output ports
- Built-in microcomputer interface circuit controlled by 16-bit serial data.

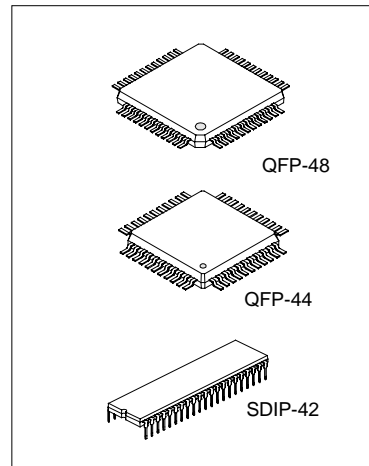

APPLICATIONS

- DVD
- TV
- Home audio equipment

RECOMMENDED OPERATING CONDITIONS

Supply voltage range	±4.5~±7.3V (analog)
	4.5~5.5V(digital)
Rated supply voltage	±7.0V (analog)
	5.0V (digital)

PIN CONFIGURATIONS

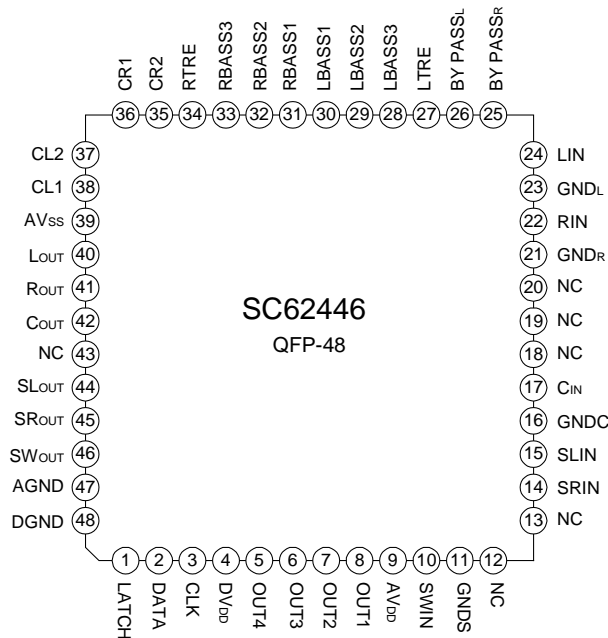
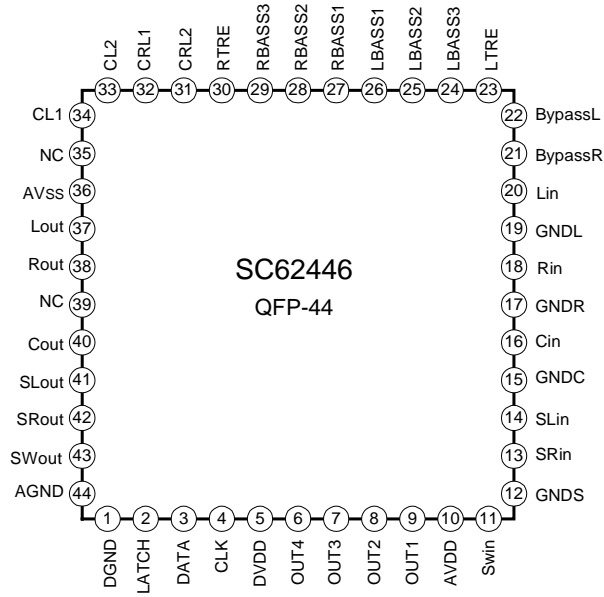

PIN CONFIGURATIONS (Continued)

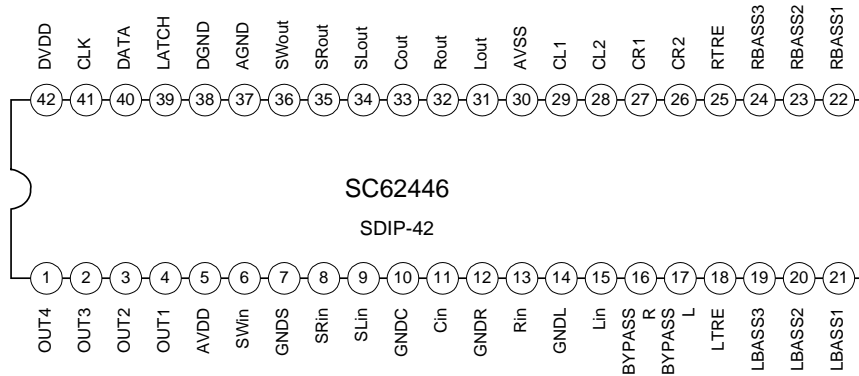

BLOCK DIAGRAM

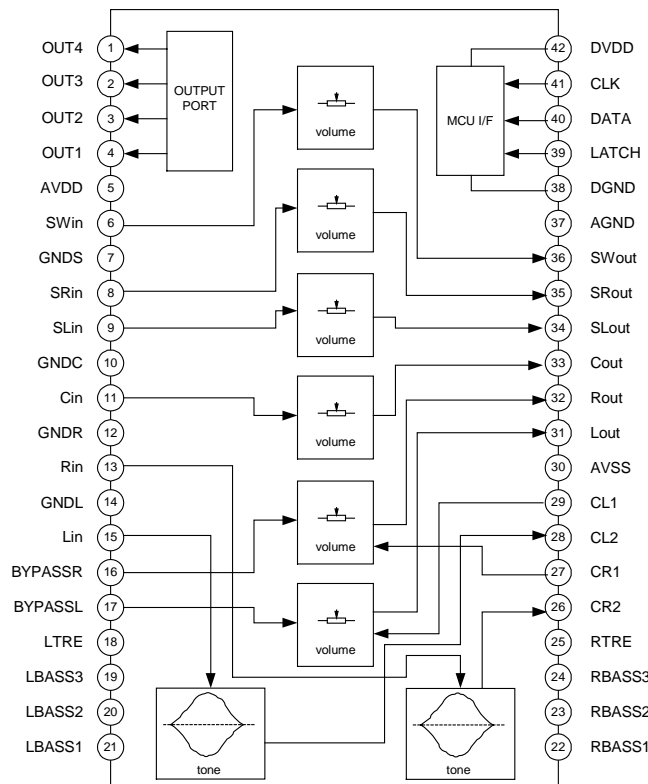

ABSOLUTE MAXIMUM RATING

Characteristic	Symbol	Value	Unit
Supply Voltage	V _{DD}	15	V
Power dissipation	P _D	1000	mW
Thermal derating	K _θ	10	mW/°C
Storage temperature	T _{STG}	-65 ~ +150	°C
Operating Temperature	T _{OPR}	-40~ + 80	°C

ELECTRICAL CHARACTERISTICS (T_{amb}=25°C, unless otherwise specified)

(1) Power supply characteristics

Parameter	Symbol	Test condition	Min	Typ	Max	Unit
Analog Positive Circuit Current	I _{DD}	Current at pin 5 No signal	--	25	35	mA
Analog Negative Circuit Current	I _{SS}	Current at pin 30 No signal	--	25	35	mA
Digital Circuit Current	I _{DD}	Current at pin 42 No signal	--	0.5	2.0	mA

(2) Input/output characteristics

Parameter	Symbol	Test condition	Min	Typ	Max	Unit
Input Resistance	R _i	13, 15, 16, 17, 27, 29 pin	35	70	150	KΩ
Maximum Output Voltage	V _{OM}	6,8,9,11,13,15,16,17pin INPUT 31~36 pin OUTPUT R _L =10KΩ, THD=1%	3.0	4.0	--	V _{rms}
Pass Gain	G _v	V _i =0.2V _{rms} , FLAT 6,8,9,11,13,15,16,17pin INPUT 31~36 pin OUTPUT	-2.0	0	2.0	dB
Distortion	THD	BW=400~30KHz V _i =0.2V _{rms} , R _L =10KΩ	--	0.02	0.09	%
Output Noise Voltage	V _n (VOL)	31~36pin, R _g =1KΩ, JIS-A, VOL=0dB	--	2	6	μV _{rms}
	V _n (tone)	31,32pin, R _g =1KΩ JIS-A, VOL=0dB	--	8	20	μV _{rms}
Maximum Attenuation	ATT _{MAX}	31~36pin, R _g =1KΩ JIS-A, VOL= - ∞ dB	-86	--	--	dB
Volume Gain Between Channel	DVOL		-1.5	0	1.5	dB
Cross Talk Between Channel	CT	V _O =0.5V _{rms} , R _L =10KΩ, JIS-A R _g =1KΩ	--	-80	-65	dB
Port Output Current	I _L	R _L =22KΩ	0.2	--	--	mA

— HANGZHOU SILAN MICROELECTRONICS JOINT-STOCK CO.,LTD —

Rev: 1.0 2000.12.31

(3) Tone control characteristics

Parameter	Symbol	Test condition	Min	Typ	Max	Unit
Tone control voltage gain	T-10dB	Vo=0.2Vrms, f=1KHz TIEBLE (f=10KHz) BASS(f=100Hz)	-12	-10	-8	dB
	T-8dB		-10	-8	-6	dB
	T-6Db		-7.5	-6	-4.5	dB
	T-4dB		-5.5	-4	-2.5	dB
	T-2dB		-3	-2	-1	dB
	T+2dB		1	2	3	dB
	T+4dB		2.5	4	5.5	dB
	T+6dB		4.5	6	7.5	dB
	T+8dB		6	8	10	dB
	T+10dB		8	10	12	dB
Balance between channel	BALT	Input pin 13, 15 Vo=0.2Vrms Output pin 31, 32	-1.5	0	+1.5	dB

RECOMMENDED OPERATING CONDITION

Parameter	Symbol	Min	Typ	Max	Unit
Analog positive supply voltage	AVDD	4.5	7.0	7.3	V
Analog negative supply voltage	AVSS	-7.3	-7.0	-4.5	V
Digital supply voltage	DVDD	4.5	5.0	5.5	V
High-level input voltage	VIH	DVDD/2+1	--	DVDD	V
Low-level input voltage	VIL	DGND	--	DVDD/2-1	V

DIGITAL BLOCK TIMING REGULATION

Parameter	Symbol	Min	Typ	Max	Unit
CLOCK cycle time	tor	8	--	--	μsec
CLOCK pulse width ("H" level)	tWHC	3.2	--	--	
CLOCK pulse width ("L" level)	tWLC	3.2	--	--	
CLOCK, DATA, LATCH rise time	tr	--	--	0.8	
CLOCK, DATA, LATCH fall time	tf	--	--	0.8	
DATA setup time	tSD	1.6	--	--	
DATA hold time	tHD	1.6	--	--	
LATCH setup time	tSL	2	--	--	
LATCH pulse width	tWHL	3.2	--	--	

DIGITAL CONTROL SPECIFICATION

Four kinds of input format options are available by changing slot settings of DE and DF. (When the IC is powered up, the internal settings are not fixed)

D01	D11	D21	D31	D41	D51	D61	D71	D81	D91	DA1	DB1	DC1	DD1	DE	DF
TONE CONTROL TREBLE				1	2	3	4	TONE CONTROL BASS				0	BY PASS 1:on, 0:off	0	0
				OUTPUT PORT n 1:high, 0:low											

D02	D12	D22	D32	D42	D52	D62	D72	D82	D92	DA2	DB2	DC2	DD2	DE	DF
VOLUME Lch							VOLUME Rch							0	1

D03	D13	D23	D33	D43	D53	D63	D73	D83	D93	DA3	DB3	DC3	DD3	DE	DF
VOLUME Cch							VOLUME SWch							1	0

D04	D14	D24	D34	D44	D54	D64	D74	D84	D94	DA4	DB4	DC4	DD4	DE	DF
VOLUME SLch							VOLUME SRch							1	1

SETTING CODE

(1) Tone control (bass/treble)

ATT	Treble	D01	D11	D21	D31
	bass	D81	D91	DA1	DB1
-10dB		1	1	1	0
-8dB		1	1	0	0
-6dB		1	0	1	1
-4dB		1	0	1	0
-2dB		1	0	0	1
+0dB		0	0	0	0
+2dB		0	0	0	1
+4dB		0	0	1	0
+6dB		0	0	1	1
+8dB		0	1	0	0
+10dB		0	1	1	0

Port output

		D41	D51	D61	D71
PORT1	0	L	--	--	--
	1	H			
PORT2	0	--	L	--	--
	1		H		
PORT3	0	--	--	L	--
	1			H	
PORT4	0	--	--	--	L
	1				H

BYPASS control

DD1	
TONE	0
BYPASS	1

Note: Do not input other data than the above.

(2), (3), (4) VOLUME

ATT	VOLUME	D0X	D1X	D2X	D3X	D4X	D5X	D6X
		D7X	D8X	D9X	DAX	DBX	DCX	DDX
	-0dB	0	0	0	0	0	0	0
	-1dB	0	0	0	0	0	0	1
	-2dB	0	0	0	0	0	1	0
	-3dB	0	0	0	0	0	1	1
	-4dB	0	0	0	0	1	0	0
	-5dB	0	0	0	0	1	0	1
	-6dB	0	0	0	0	1	1	0
	-7dB	0	0	0	0	1	1	1
	-8dB	0	0	0	1	0	0	0
	-9dB	0	0	0	1	0	0	1
	-10dB	0	0	0	1	0	1	0
	-11dB	0	0	0	1	0	1	1
	-12dB	0	0	0	1	1	0	0
	-13dB	0	0	0	1	1	0	1
	-14dB	0	0	0	1	1	1	0
	-15dB	0	0	0	1	1	1	1
	-16dB	0	0	1	0	0	0	0
	-17dB	0	0	1	0	0	0	1

(To be continued)

(Continued)

ATT	VOLUME	D0X	D1X	D2X	D3X	D4X	D5X	D6X
		D7X	D8X	D9X	DAX	DBX	DCX	DDX
-18dB	0	0	0	1	0	0	1	0
-19dB	0	0	0	1	0	0	1	1
-20dB	0	0	0	1	0	1	0	0
-21dB	0	0	0	1	0	1	0	1
-22dB	0	0	0	1	0	1	1	0
-23dB	0	0	0	1	0	1	1	1
-24dB	0	0	0	1	1	0	0	0
-25dB	0	0	0	1	1	0	0	1
-26dB	0	0	0	1	1	0	1	0
-27dB	0	0	0	1	1	0	1	1
-28dB	0	0	0	1	1	1	0	0
-29dB	0	0	0	1	1	1	0	1
-30dB	0	0	0	1	1	1	1	0
-31dB	0	0	0	1	1	1	1	1
-32dB	0	1	0	0	0	0	0	0
-33dB	0	1	0	0	0	0	0	1
-34dB	0	1	0	0	0	0	1	0
-35dB	0	1	0	0	0	0	1	1
-36dB	0	1	0	0	0	1	0	0
-37dB	0	1	0	0	0	1	0	1
-38dB	0	1	0	0	0	1	1	0
-39dB	0	1	0	0	0	1	1	1
-40dB	0	1	0	1	0	0	0	0
-41dB	0	1	0	1	0	0	0	1
-42dB	0	1	0	1	0	0	1	0
-43dB	0	1	0	1	0	0	1	1
-44dB	0	1	0	1	1	1	0	0
-45dB	0	1	0	1	1	1	0	1
-46dB	0	1	0	1	1	1	1	0
-47dB	0	1	0	1	1	1	1	1
-48 dB	0	1	1	0	0	0	0	0
-49 dB	0	1	1	0	0	0	0	1
-50 dB	0	1	1	0	0	0	1	0
-51 dB	0	1	1	0	0	0	1	1

(To be continued)

(Continued)

ATT	VOLUME	D0X	D1X	D2X	D3X	D4X	D5X	D6X
		D7X	D8X	D9X	DAX	DBX	DCX	DDX
-52 dB	0	1	1	0	1	0	0	
-53 dB	0	1	1	0	1	0	1	
-54dB	0	1	1	0	1	1	0	
-55dB	0	1	1	0	1	1	1	
-56dB	0	1	1	1	0	0	0	
-57dB	0	1	1	1	0	0	1	
-58dB	0	1	1	1	0	1	0	
-59dB	0	1	1	1	0	1	1	
-60dB	0	1	1	1	1	0	0	
-61dB	0	1	1	1	1	0	1	
-62dB	0	1	1	1	1	1	0	
-63dB	0	1	1	1	1	1	1	
-64dB	1	0	0	0	0	0	0	
-65dB	1	0	0	0	0	0	1	
-66dB	1	0	0	0	0	1	0	
-67dB	1	0	0	0	0	1	1	
-68dB	1	0	0	0	1	0	0	
-69dB	1	0	0	0	1	0	1	
-70dB	1	0	0	0	1	1	0	
-71dB	1	0	0	0	1	1	1	
-72dB	1	0	0	1	0	0	0	
-73dB	1	0	0	1	0	0	1	
-74dB	1	0	0	1	0	1	0	
-75dB	1	0	0	1	0	1	1	
-76dB	1	0	0	1	1	0	0	
-77dB	1	0	0	1	1	0	1	
-78dB	1	0	0	1	1	1	0	
-79dB	1	0	0	1	1	1	1	
-∞dB	1	0	0	0	0	0	0	

THERMAL DERATING

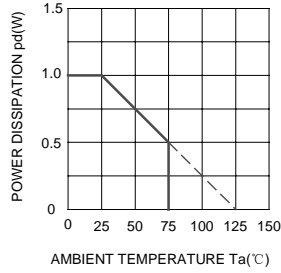

TIMING DIAGRAM

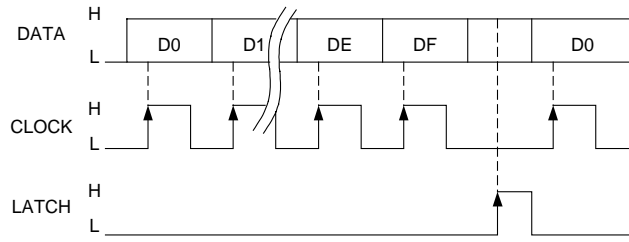

note: CLOCK and LATCH function at raising edges of pulse

DATA timing

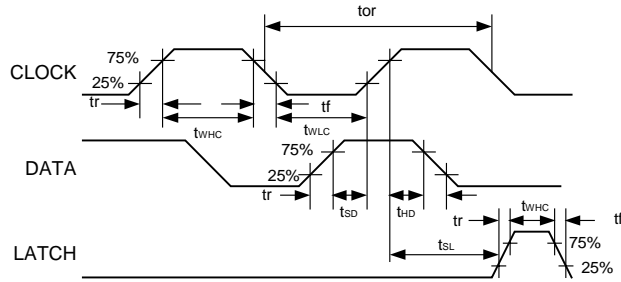

CLOCK, DATA, LATCH timing

SYSTEM DIAGRAM

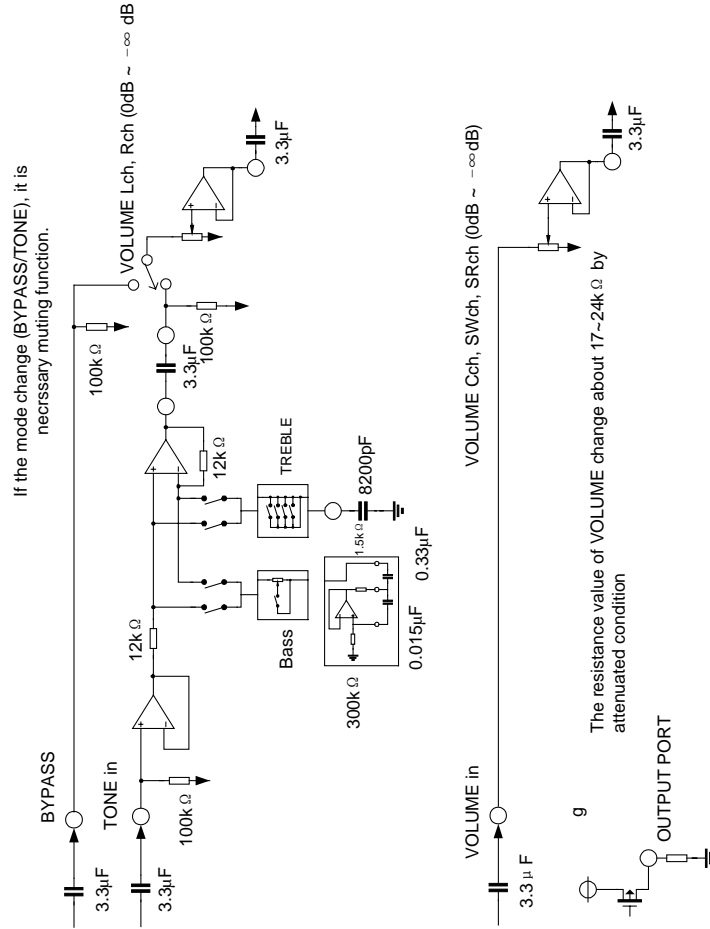

TYPICAL APPLICATION CIRCUIT

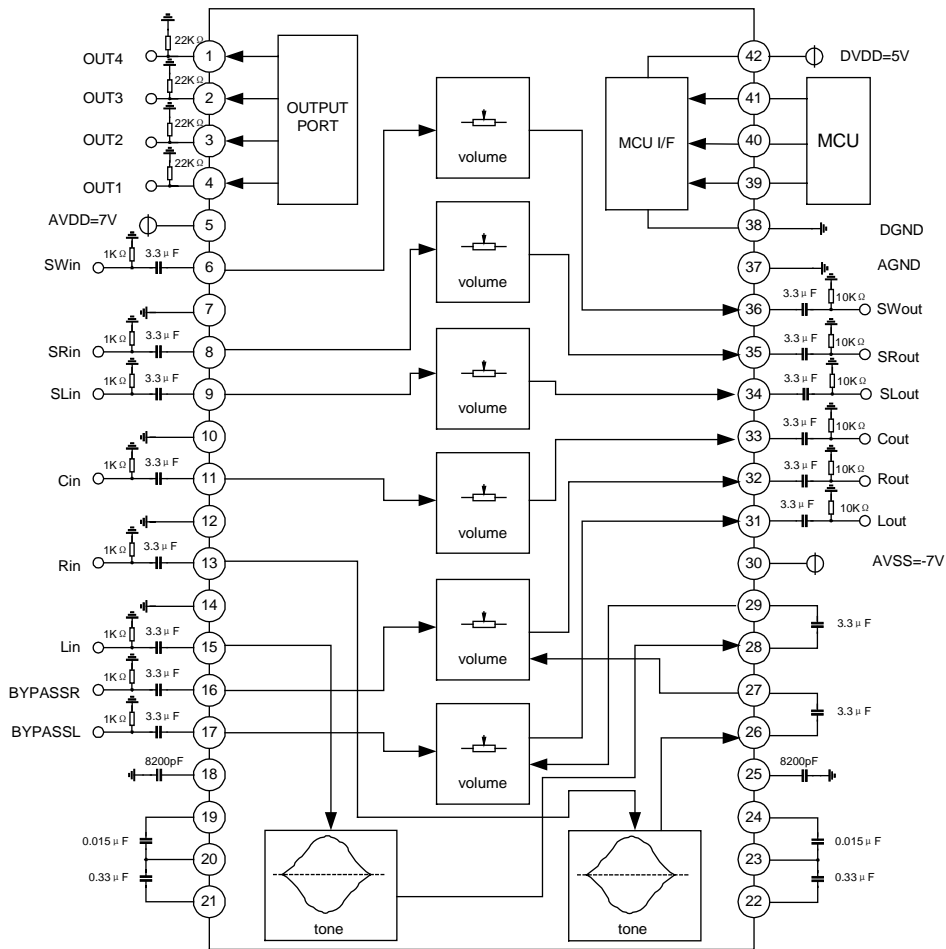

PACKAGE OUTLINE

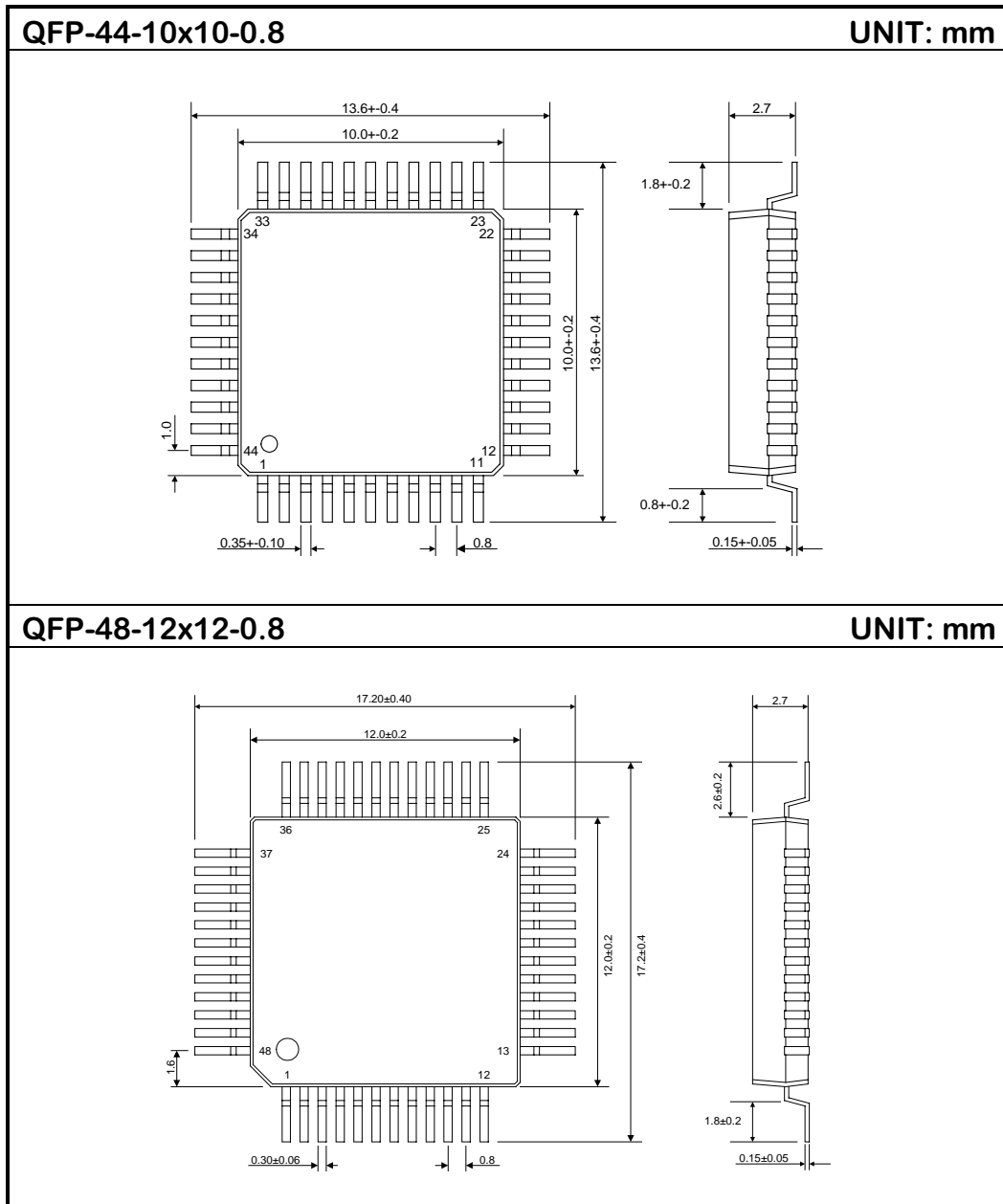

PACKAGE OUTLINE (Continued)

