

DTMF RECEIVER

DESCRIPTION

The SC9270C/D is a complete DTMF receiver integrating both the bandsplit filter and digital decoder functions. The filter section uses switched capacitor techniques for high- and low-group filters and dial-tone rejection. Digital counting techniques are employed in the decoder to detect and decode all 16 DTMF tone-pairs into a 4-bit code. External component count is minimized by on-chip provision of a differential input amplifier, clock-oscillator and latched 3-state bus interface.

FEATURES

- *Complete receiver in an 18-pin package
- *Excellent performance
- *CMOS, single 5 volt operation,
- *Widely operating voltage: 1.2V ~ 5.25V
- *Minimum board area
- *Central office quality
- *Low power consumption
- *Power-Down mode (SC9270D only)
- *Inhibit-mode (SC9270D only)

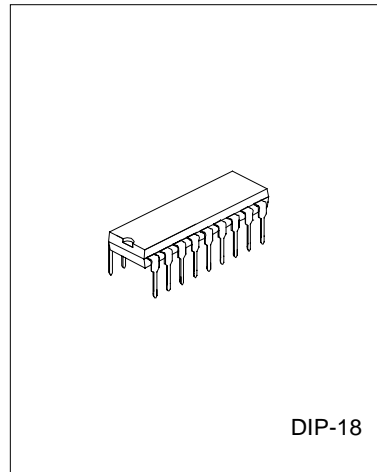

APPLICATIONS

- *Paging systems
- *Repeater systems / Mobile radio
- *Credit card systems
- *Remote control
- *Personal computers

PIN CONFIGURATIONS

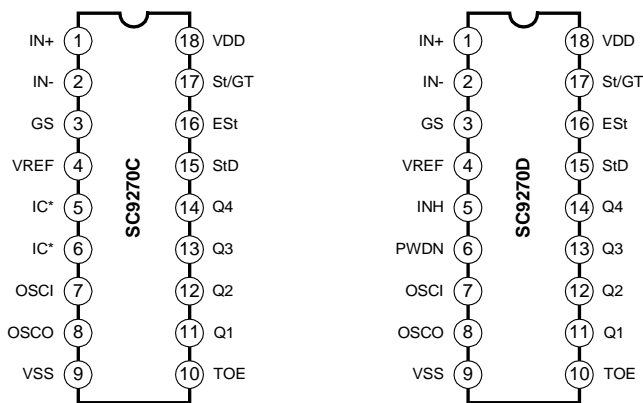

BLOCK DIAGRAM

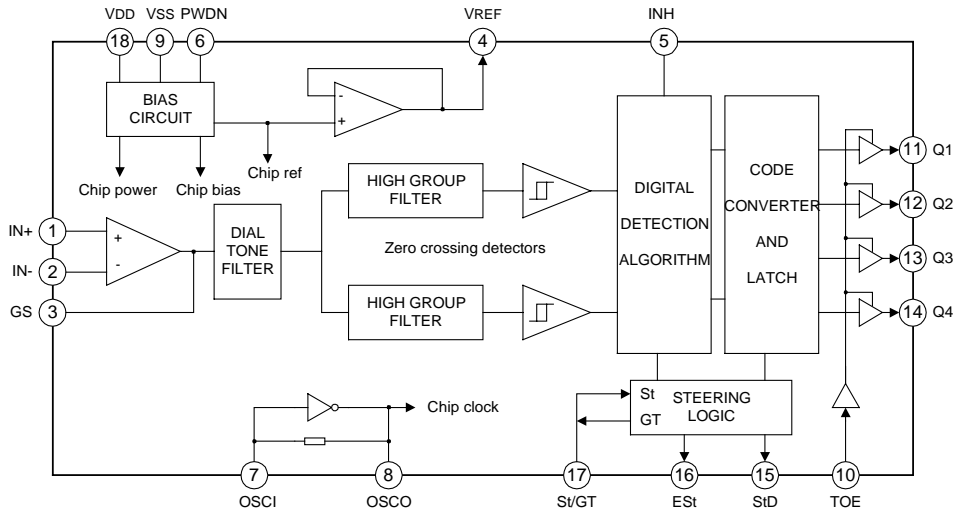

Figure 1. block diagram

ABSOLUTE MAXIMUM RATINGS (Notes 1, 2, 3)

Characteristic	Symbol	Value	Unit
Power Supply Voltage	VDD-VSS	6	V
Voltage on any pin	--	VSS-0.3 ~ VDD+0.3	V
Current at any pin	--	10	mA
Operating temperature	Topr	-40~+85	°C
Storage Temperature	Tstg	-65~+150	°C
Package power dissipation		500	mW

Note: 1. Absolute maximum ratings are those values beyond which damage to the device may occur.

2. Unless otherwise specified, all voltages are referenced to ground.

3. Power dissipation temperature derating: -12 mW / from 65°C to 85°C

RECOMMENDED OPERATING CONDITIONS (Note 1)

Parameter	Symbol	Conditions	Min	Typ(Note 2)	Max	Unit
Positive Supply Voltages	VDD	VSS=0V	1.2	5	--	V
Oscillator Clock Frequency	fc	--	--	3.579545	--	MHz
Oscillator Frequency Tolerance	Δfc	--	--	±0.1	--	%

Note: 1. Voltages are with respect to ground(Vss), unless otherwise stated.

2. Typical figures are at 25°C and are for design aid only: not guaranteed and not subject to production testing.

— HANGZHOU SILAN MICROELECTRONICS JOINT-STOCK CO.,LTD —

DC ELECTRICAL CHARACTERISTICS

Parameter	Symbol	Conditions	Min	Typ	Max	Unit
SUPPLY						
Operating Supply Voltage	VDD	--	1.2	--	5.25	V
Operating Supply Current	I _{CC}	--	--	3.0	7.0	mA
Power Consumption	P _O	f=3.579MHz; VDD=5V	--	15	35	mW
Standby Current	I _S	PWDN pin = VDD	--	--	100	μA
INPUTS						
Low Level Input Voltage	V _{IL}	--	--	--	1.5	V
High Level Input Voltage	V _{IH}	--	3.5	--	--	V
Input Leakage Current	I _{IH} /I _{IL}	V _{IN} = V _{SS} or VDD	--	0.1	--	μA
Pull up(Source) Current	I _{SO}	TOE(Pin 10)=0V	--	7.5	15	μA
Input Impedance (IN+, IN-)	R _{IN}	@1kHz	--	10	--	MΩ
Steering Threshold Voltage	V _{Tst}	--	--	2.35	--	V
OUTPUTS						
Low Level Output Voltage	V _{OL}	No load	--	0.03	--	V
High Level Output Voltage	V _{OH}	No load	--	4.97	--	μA
Output Low(Sink) Current	I _{OL}	V _{OUT} =0.4V	1.0	2.5	--	mA
Output High(Source) Current	I _{OH}	V _{OUT} =4.6V	0.4	0.8	--	mA
VREF Output Voltage	V _{REF}	No load	2.4	--	2.7	V
VREF Output Resistance	R _{OR}	--	--	10	--	kΩ

OPERATING CHARACTERISTICS
Gain Setting Amplifier

Parameter	Symbol	Conditions	Min	Typ	Max	Unit
Input Leakage Current	I _{IN}	V _{SS} < V _{IN} < VDD	--	±100	--	nA
Input Resistance	R _{IN}	--	--	10	--	MΩ
Input Offset Voltage	V _{OS}	--	--	±25	--	mV
Power Supply Rejection	PSRR	1kHz	--	60	--	dB
Common Mode Rejection	CMRR	-3.0V < V _{IN} < 3.0V	--	60	--	dB
DC Open Loop Voltage Gain	A _{VOL}	--	--	65	--	dB
Open Loop Unity Gain Bandwidth	f _C	--	--	1.5	--	MHz
Output Voltage Swing	V _O	R _L ≥ 100kΩ to V _{SS}	--	4.5	--	V _{PP}
Tolerable capacitive load(GS)	C _L	--	--	100	--	PF
Tolerable resistive load(GS)	R _L	--	--	50	--	kΩ
Common Mode Range	V _{CM}	No load	--	3.0	--	V _{PP}

Notes : 1. All voltages referenced to VDD unless otherwise noted.

2. VDD = 5.0V, VSS = 0V, T_A = 25°C .

———— **HANGZHOU SILAN MICROELECTRONICS JOINT-STOCK CO.,LTD** ————

Rev: 1.1 2001.04.27

AC CHARACTERISTICS (All voltage referenced to Vss otherwise noted; VDD=5.0V, VSS=0V, TA=25°C, fCLK=3.579545 MHz, using test circuit of figure 2 & 3. Typical figures are at 25°C and are for design aid only: not guaranteed and not subject to production testing)

Parameter	Symbol	Test Conditions	Min	Typ	Max	Unit
SIGNAL CONDITIONS						
Valid Input Signal Levels (each tone of composite signal)	--	Note:1,2,3,5,6,9,11	--	--	-40	dBm
	--	Note:1,2,3,5,6,9,11	--	--	7.75	mVRMS
	--	Note:1,2,3,5,6,9,11	+1	--	--	dBm
	--	Note:1,2,3,5,6,9,11	883	--	--	mVRMS
Positive Twist Accept	--	Note:2,3,6,9,11	--	10	--	dB
Negative Twist Accept	--	Note:2,3,6,9,11	--	10	--	dB
Frequency Deviation Accept Limit	--	Note:2,3,5,9,11	--	±1.5%±2Hz	--	
Frequency Deviation Reject Limit	--	Note:2,3,5,11	±3.5	--	--	
Thrid Tone Tolerance	--	Note:2,3,4,5,9,13	-18.5		--	dB
Noise Tolerance	--	Note:2,3,4,5,7,9,10	--	-12		dB
Dial Tone Tolerance	--	Note:2,3,4,5,8,9,11	--	+18	--	dB
TIMING						
Tone Present Detection Time	tDP	Refer to Fig. 4. Note:12	5	14	16	ms
Tone Absent Detection Time	tDA	Refer to Fig. 4. Note:12	0.5	4	8.5	ms
Tone Duration Accept	tREC	User adjustable	--	--	40	ms
Tone Duration Reject	tREC	User adjustable	20	--	--	ms
Interdigit Pause Accept	tID	User adjustable	--	--	40	ms
Interdigit Pause Reject	tDO	User adjustable	20	--	--	ms
OUTPUTS						
Propagation Delay (St to Q)	tPQ	TOE=VDD	--	8	11	µs
Propagation Delay (St to StD)	tPSED	TOE=VDD	--	12	--	µs
Output Data Set Up (Q to Std)	tQSED	TOE=VDD	--	4.5	--	µs
Propagation Delay (TOE to Q Enable)	tPTE	RL=10kΩ, CL=50pf	--	50	--	ns
Propagation Delay (TOE to Q Disable)	tPTD	RL=10kΩ, CL=50pf	--	300	--	ns
CLOCK						
Crystal/Clock Frequency	fC	--	3.5759	3.5759	3.581	MHz
Clock Input Rise Time	tLHCL	Ext. clock	--	--	110	ns
Clock Input Fall Time	tHLCL	Ext. clock	--	--	110	ns
Clock Input Duty Time	DCCL	Ext. clock	40	50	60	%
Capacitive Load (OSCO)	CLO	--	--	--	30	pf

Notes: 1. dBm = decibels above or below a reference power of 1mW into a 600 Ohm load.

2. Digit sequences consists of all 16 DTMF tones.

— **HANGZHOU SILAN MICROELECTRONICS JOINT-STOCK CO.,LTD** —

Rev: 1.1 2001.04.27

3. Tone duration = 40mS Tone pause = 40mS.
4. Nominal DTMF frequencies are used.
5. Both tones in the composite signal have an equal amplitude.
6. Tone pair is deviated by $\pm 1.5\% \pm 2\text{Hz}$.
7. Bandwidth limited (3kHz) Gaussian Noise.
8. The precise dial tone frequencies are (350Hz and 440Hz) $\pm 2\%$.
9. For an error rate of less than 1 in 10,000.
10. Referenced to the lowest level frequency component in DTMF signal.
11. Referenced to the minimum valid accept.
12. For guard time calculation purpose.
13. Referenced to Fig.10 Input DTMF Tone level at -25dBm (-28dBm at GS Pin) interference Frequency Range between 480—3400Hz.

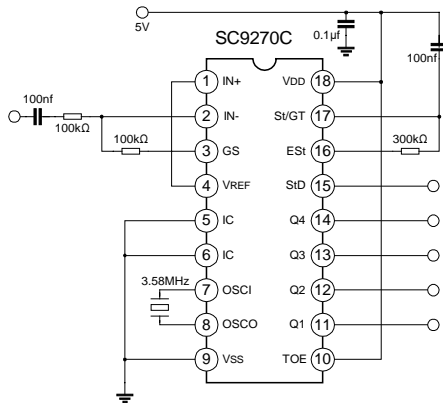

Figure 2. Single ended input cofiguration

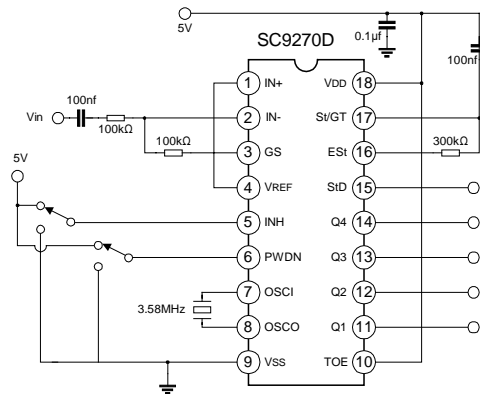

Figure 3. Single ended input cofiguration

PIN DESCRIPTION

Pin No.	Pin Name	I/O	Description	
1	IN+	I	Non-Inverting input	Connections to the front-end differential amplifier.
2	IN-	I	Inverting input	
3	GS	--	Gain select. Gives access to output of front-end differential amplifier for connection of feedback resistor.	
4	VREF	O	Reference voltage output, nominally VDD/2. May be used to bias the inputs at mid-rail (see application diagram).	
5	INH	I	Inhibit (input) logic high inhibit the detection of 1633Hz internal built-in pull down resistor. (SC9270D only). (For SC9270C, this pin must be tied to VSS)	
6	PWDN	I	Power down (input). Active high power down the device and inhibit the oscillator internal built-in pull down resistor. (SC9270D only). (For SC9270C, this pin must be tied to VSS)	
7	OSC1	I	Clock Input	3.579545MHz crystal connected between these pins completes internal oscillator.
8	OSC2	O	Clock Output	
9	VSS	--	Negative power supply, normally connected to 0V.	
10	TOE	I	3-state data output enable. Logic high enables the outputs Q1-Q4. This pin is Internally pulled up.	
11~14	Q1 ~ Q4	O	3-state data outputs. When enabled by TOE, provide the code corresponding to the last valid tone-pair received (see Table 1). When TOE is logic low, the data outputs are high impedance.	
15	StD	O	Delayed steering output. Presents a logic high when a received tone-pair has been registered and the output latch updated; returns to logic low when the voltage on St/GT falls below VTSt.	
16	ESst	O	Early steering output. Presents a logic high immediately when the digital algorithm detects a recognizable tone-pair (signal condition). Any momentary loss of signal condition will cause ESst to return to a logic low.	
17	St/GT	I/O	Steering input/guard time output (bi-directional). A voltage greater than VTSt detected at St causes the device to register the detected tone-pair and update the output latch. A voltage less than VTSt frees the device to accept a new tone-pair. The GT output acts to reset the external steering time-constant; its state is a function of ESst and the voltage on St.	
18	VDD	--	Positive power supply.	

TIMING DIAGRAM

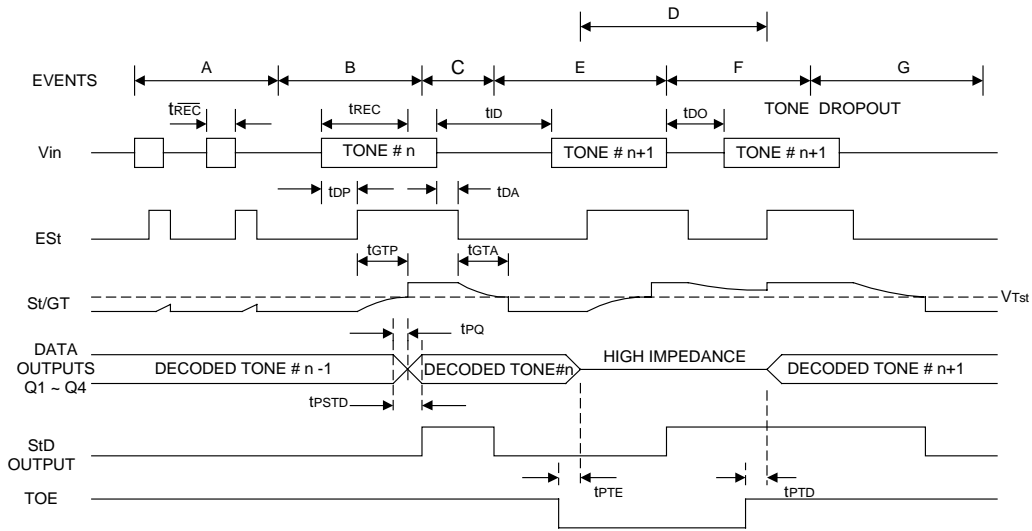

Figure 4. Timing diagram

EXPLANATION OF EVENTS	EXPLANATION OF SYMBOLS
A. Short tone bursts: detected. Tone duration is invalid.	V_{in} : DTMF composite input signal.
B. Tone #n is detected. Tone duration is valid. Decoded to outputs.	t_{REC} : Maximum DTMF signal duration not detected as valid.
C. End of tone #n is detected and validated.	t_{REC} : Minimum DTMF Signal duration required for valid recognition.
D. 3 State outputs disabled (high impedance).	t_{ID} : Minimum time between valid DTMF signals.
E. Tone #n + 1 is detected. Tone duration is valid. Decoded to outputs.	t_{DO} : Maximum allowable dropout during valid DTMF signal
F. Tristate outputs are enabled. Acceptable drop out of tone #n + 1 does not register at outputs.	t_{DP} : Time to detect the presence of valid DTMF signals.
G. End of tone #n + 1 is detected and validated.	t_{DPA} : Time to detect the absence of valid DTMF signals.
	t_{GTP} : Guard Time, Tone present.
	t_{GTA} : Guard Time, Tone absent.

FUNCTION DESCRIPTIONS

The SC9270C/D monolithic DTMF receiver offers small size, low power consumption and high performance. Its architecture consists of a bandsplit filter section, which separates the high and low tones of receiver pair, followed by a digital counting section which verifies the frequency and duration of the received tones before passing the corresponding code to the output bus.

1. FILTER SECTION

Separation of the low-group and high-group tones is achieved by applying the dual tone signal to the inputs of two filters a sixth order for the high group and an eighth order for the low group. The bandwidths of which correspond to the bands enclosing the low-group and high-group tones (see table 1). The filter section also incorporates notches at 350Hz and 440 Hz for exceptional dial-tone rejection. Each filter output is followed by a second-order switched-capacitor section which smooth the signals prior to limiting. Limiting is performed by high-gain comparators which are provided with hysteresis to prevent detection of unwanted low-level signals and noise; the outputs of the comparators provide full-rail logic swings at the frequencies of the incoming tones.

Flow	Fhigh	KEY	TOE	Q4	Q3	Q2	Q1
697	1209	1	H	0	0	0	1
697	1336	2	H	0	0	1	0
697	1477	3	H	0	0	1	1
770	1209	4	H	0	1	0	0
770	1336	5	H	0	1	0	1
770	1477	6	H	0	1	1	0
852	1209	7	H	0	1	1	1
852	1336	8	H	1	0	0	0
852	1477	9	H	1	0	0	1
941	1336	0	H	1	0	1	0
941	1209	*	H	1	0	1	1
941	1477	#	H	1	1	0	0
697	1633	A	H	1	1	0	1
770	1633	B	H	1	1	1	0
852	1633	C	H	1	1	1	1
941	1633	D	H	0	0	0	0
--	--	ANY	L	Z	Z	Z	Z
L=LOGIC LOW, H=LOGIC HIGH, Z=HIGH IMPEDANCE							
Table 1: Function decode table							

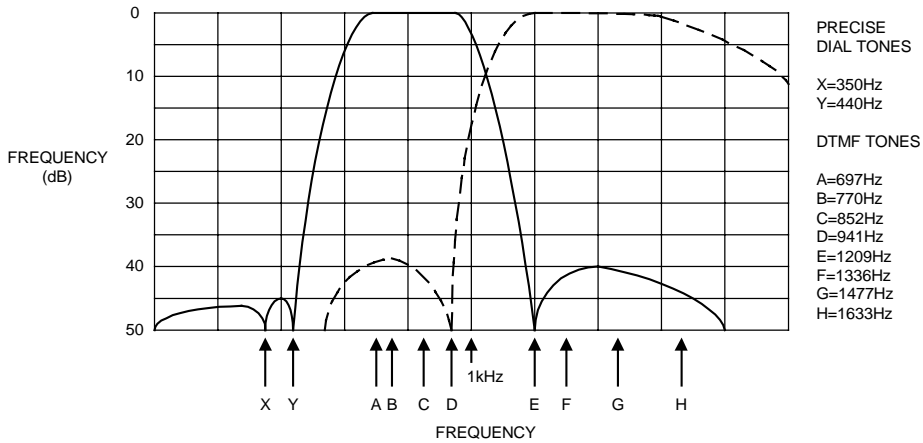

Figure 5. Filter Response

2. DECODER SECTION

The decoder used digital counting techniques to determine the frequencies of the limited tones and to verify that they correspond to standard DTMF frequencies. A complex averaging algorithm(protects) against tone simulation by extraneous signals, such as voice, while providing tolerance to small frequency deviations and variations. This averaging algorithm has been developed to ensure an optimum combination of immunity to “talk-off” and tolerance to the presence of interfering signals (“third tones”) and noise. When the detector recognizes the simultaneous presence of two valid tones (referred to as “signal condition” in some industry specifications), it raises the “early steering” flag (ESt). Any subsequent loss of signal condition will cause ESt to fall.

3. STEERING CIRCUIT

Before registration of a decoded tone-pair, the receiver checks for a valid signal duration (referred to as “character- recognition-condition”). This check is performed by an external RC time-constant driven by ESt. A logic high on ESt causes Vc (see Fig.4) to rise as the capacitor discharges. Provided signal-condition is maintained (ESt remains high) for the validation period (tGTP), Vc reaches the threshold (VTSt) of the steering logic to register the tone-pair, latching its corresponding 4-bit code (see Fig.3) into the output latch. At this point, the GT output is activated and drives Vc to VDD. GT

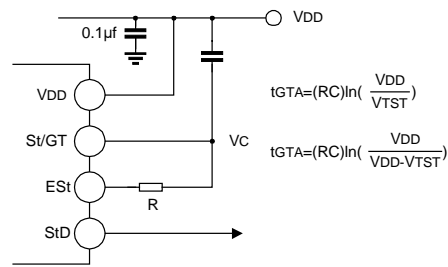

Figure 6. Basic steering Circuit

continues to drive high as long as ESt remains high. Finally after a short delay to allow the output latch to settle, the “delayed-steering” output flag, StD, goes high, signaling that a received tone-pair has been registered. The contents of the output latch are made available on the 4-bit output bus by raising the 3-state control input (TOE) to a logic high. The steering circuit works in reverse to validate the interdigit pause between signals. Thus, as well as rejecting signals too short to be considered valid, the receiver will tolerate signal interruptions (“drop-out”) too short to be considered a valid pause. The facility, together with the capability of selecting the steering time-constants externally, allows the designer to tailor performance to meet a wide variety of system requirements.

4. GUARD TIME ADJUSTMENT

In many situations not requiring independent selection of receive and pause, the simple steering circuit of Fig.6 is applicable. Component values are chosen according to the following formulae:

$$t_{REC} = t_{DP} + t_{GTP} \qquad t_{ID} = t_{DA} + t_{GTA}$$

The value of t_{DP} is a parameter of the device (see table) and t_{REC} is the minimum signal duration to be recognized by the receiver. A value for C of 0.1 μ F is recommended for most applications, leaving R to be selected by the designer. For example, a suitable value of R for a t_{REC} of 40mS would be 300k. Different steering arrangements may be used to select independently the guard-times for tone-present (t_{GTP}) and tone-absent (t_{GTA}). This may be necessary to meet system specifications which place both accept and reject limits on both tone duration and interdigital pause. Guard-time adjustment also allows the designer to tailor system parameters such as talk off and noise immunity. Increasing t_{REC} improves talk-off performance, since it reduces the probability that tones simulated by speech will maintain signal condition for long enough to be registered. On the other hand, a relatively short t_{REC} with a long t_{DO} would be appropriate for extremely noisy environments where fast acquisition time and immunity to drop - outs would be required. Design information for guard-time adjustment is shown in Fig.7.

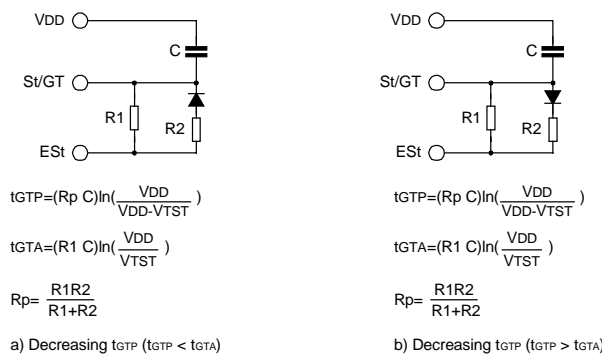

Figure 7. Guard time adjustment

5. INPUT CONFIGURATION

The input arrangement of the SC9270C/D provides a differential-input operational amplifier as well as a bias source (VREF) which is used to bias the inputs at mid-rail.

Provision is made for connection of a feedback resistor to the op-amp output (GS) for adjustment of gain. In a single-ended configuration, the input pins are connected as shown in Fig.2 with the op-amp connected for unity gain and VREF biasing the input at 1/2VDD.

Fig.8 shows the differential configuration, which permits the adjustment of gain with the feedback resistor R5.

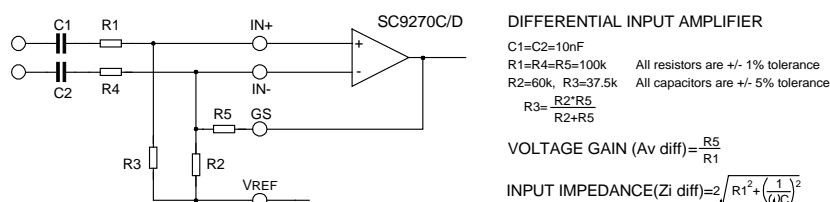

Figure 8. Differential input configuration

6. POWER – DOWN AND INHIBIT MODE

A logic high applied to pin 6 (PVDN) will power the device to minimize the power consumption in a standby mode. It stops the oscillator and the functions of the filters.

Inhibit mode is enabled by a logic high input to the pin 5 (INH). It inhibits the detection of 1633 Hz. The output code will remain the same as the previous detected code (see table 2).

fLOW	Fhigh	KEY	TOE	Q4	Q3	Q2	Q1	fLOW	Fhigh	KEY	TOE	Q4	Q3	Q2	Q1
697	1209	1	H	L	L	L	H	697	1209	4	H	L	H	L	L
697	1336	2	H	L	L	H	L	697	1336	5	H	L	H	L	H
697	1477	3	H	L	L	H	H	697	1477	6	H	L	H	H	L
770	1209	4	H	L	H	L	L	770	1209	7	H	L	H	H	H
770	1336	5	H	L	H	L	H	770	1336	8	H	H	L	L	L
770	1477	6	H	L	H	H	L	770	1477	9	H	H	L	L	H
852	1209	7	H	L	H	H	H	852	1336	0	H	H	L	H	L
852	1336	8	H	H	L	L	L	852	1477	*	H	H	L	H	H
852	1477	9	H	H	L	L	H	852	1209	#	H	H	H	L	L
941	1336	0	H	H	L	H	L	852	1633	A	H	H	H	L	H
941	1209	*	H	H	L	H	H	770	1633	B	H	H	H	H	L
941	1477	#	H	H	H	L	L	852	1633	C	H	H	H	H	H
697	1633	A	H	H	H	L	H	941	1633	D	H	L	L	L	L
770	1633	B	H	H	H	H	L	--	--	ANY	L	Z	Z	Z	Z
852	1633	C	H	H	H	H	H	PREVIOUS DATA							
941	1633	D	H	L	L	L	L								
--	--	ANY	L	Z	Z	Z	Z								
--	--	ANY	L	Z	Z	Z	Z								

Table 2: Truth table
 (Z: high impedance) INH = VSS INH = VDD

6. CRYSTAL OSCILLATOR

The internal clock circuit is completed with the addition of an external 3.579545MHz crystal and is normally connected as shown in Figure 2. However, it is possible to configure several SC9270C/D devices employing only a single oscillator crystal. The oscillator output of the first device in the chain is coupled through a 30pF capacitor to the oscillator input (OSCI) of the next device. Subsequent devices are connected in a similar fashion. Refer to Figure 9 for details. The problems associated with unbalanced loading are not a concern with the arrangement shown, ie: precision balancing capacitors are not required.

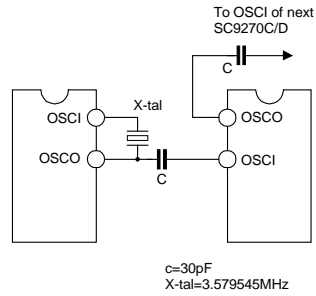

Figure 9 Oscillator Connection

PACKAGE OUTLINE

