

Surface Mount Schottky Barrier Diodes

Features

- Low Forward Voltage

PINNING

PIN	DESCRIPTION
1	Cathode
2	Anode

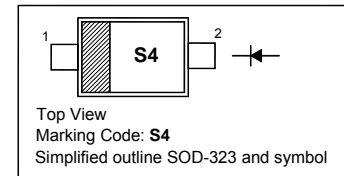

Absolute Maximum Ratings ($T_a = 25\text{ }^\circ\text{C}$)

Parameter	Symbol	Value	Unit	
Peak Repetitive Reverse Voltage	V_{RRM}	SD103AWS SD103BWS SD103CWS	40 30 20	V
Reverse Voltage		SD103AWS SD103BWS SD103CWS	40 30 20	V
Average Forward Rectified Current		$I_{F(AV)}$	350	mA
Non-Repetitive Peak Forward Surge Current at $t = 1\text{ s}$	I_{FSM}	2	A	
Power Dissipation	P_{tot}	200	mW	
Operating and Storage Temperature Range	T_j, T_{stg}	- 65 to + 125	$^\circ\text{C}$	

Characteristics at $T_a = 25\text{ }^\circ\text{C}$

Parameter	Symbol	Min.	Typ.	Max.	Unit	
Reverse Breakdown Voltage at $I_R = 10\text{ }\mu\text{A}$	$V_{(BR)R}$	SD103AWS SD103BWS SD103CWS	40 30 20	- - -	V	
Reverse Leakage Current at $V_R = 30\text{ V}$ at $V_R = 20\text{ V}$ at $V_R = 10\text{ V}$		I_R	SD103AWS SD103BWS SD103CWS	- - -	5 5 5	μA
Forward Voltage at $I_F = 20\text{ mA}$ at $I_F = 200\text{ mA}$			V_F	- -	- -	0.37 0.6
Total Capacitance at $V_R = 0\text{ V}$, $f = 1\text{ MHz}$	C_T			-	50	-
Reverse Recovery Time at $I_F = I_R = 200\text{ mA}$, $I_{rr} = 0.1 I_R$, $R_L = 100\text{ }\Omega$	t_{rr}	-	10	-	ns	

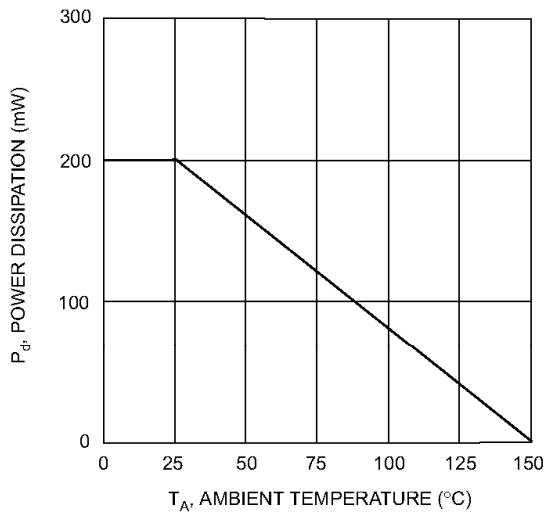

Fig. 1 Power Derating Curve

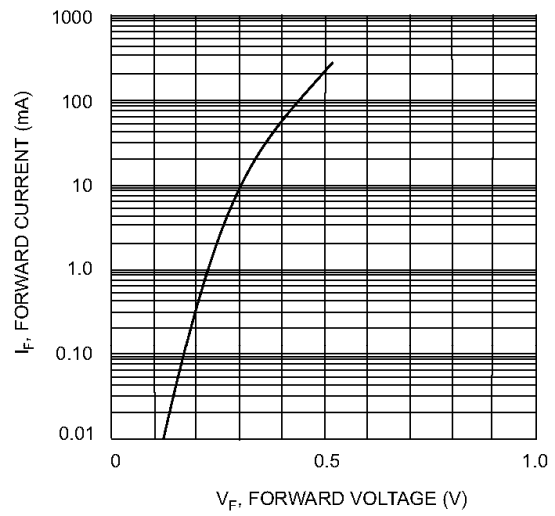

Fig. 2 Typical Forward Characteristics

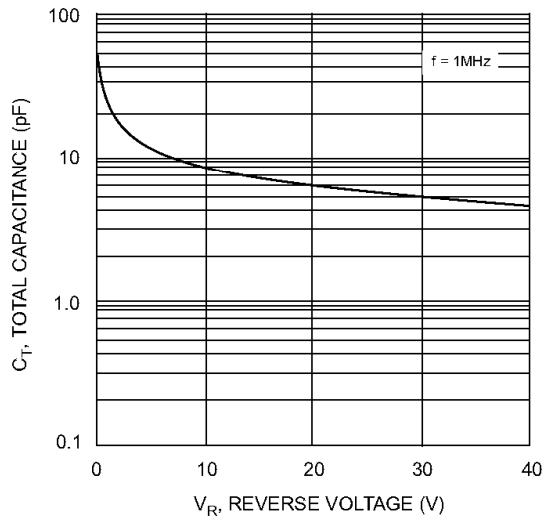
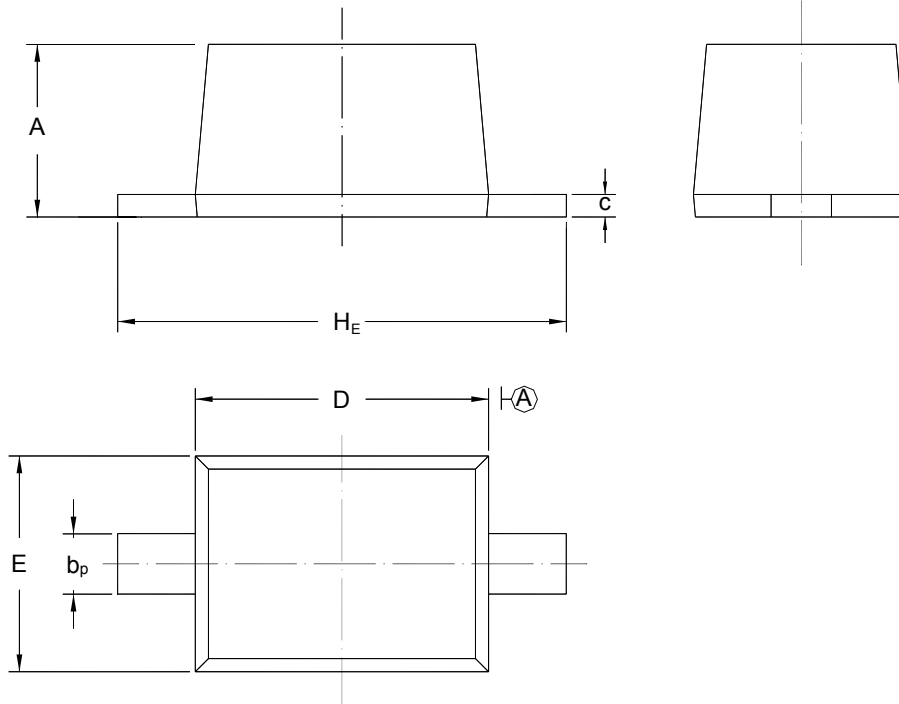

Fig. 3 Total Capacitance vs Reverse Voltage

PACKAGE OUTLINE

Plastic surface mounted package; 2 leads

SOD-323



UNIT	A	b_p	C	D	E	H_E
mm	1.10 0.80	0.40 0.25	0.15 0.00	1.80 1.60	1.35 1.15	2.80 2.30