

General Description

The SDC2921 is a Pulse–Width Modulation (PWM) control circuit with complete protection circuits for the SMPS (Switching Mode Power Supply). It contains various functions, can minimize external components of switching power supply systems in personal computer.

Features

- Complete PWM control and protection circuits
- Over voltage protection for 3.3V/ 5V/ 12V/ PT
- Under voltage protection for 3.3V/ 5V/ 12V
- 280ms PG time delay
- Open drain power good output
- 280ms time delay for UVP
- Remote ON/OFF function
- Built-in soft-start function
- Package: DIP-16

Applications

- PC power supply

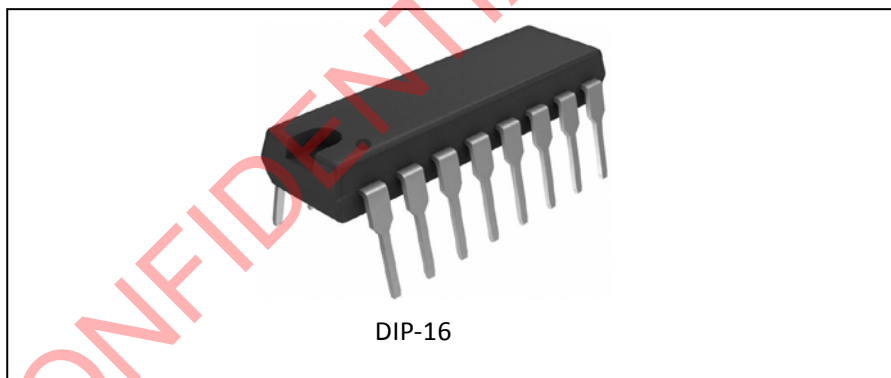

Figure 1. Package Type

Pin Configuration

Figure 2. Pin Configuration

Pin Number	Pin Name	Function
1	V33	OVP/UVI input for 3.3V
2	V5	OVP/UVI input for 5V
3	V12	OVP/UVI input for 12V
4	PT	Extra OVP protection input
5	GND	Ground
6	RT	Oscillation frequency set by external resistor
7	C1	PWM open drain output 1
8	C2	PWM open drain output 2
9	REM	Remote on/off input
10	SS	Soft start function set by external capacitor
11	PG	Power good signal
12	DET	Extra protection input
13	VCC	Supply voltage
14	OPOUT	OP output
15	VIN-	OP negative input
16	VIN+	OP positive input

Table 1. Pin Description

Functional Block Diagram

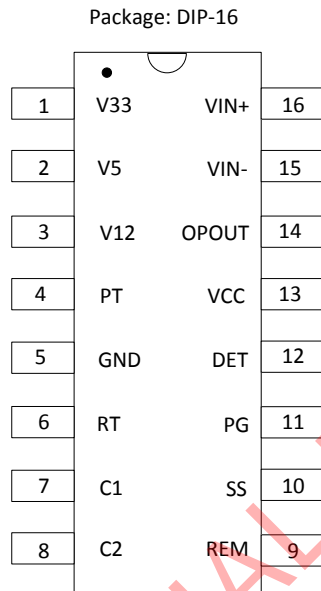
Figure 3. Functional Block Diagram

Ordering Information

Package	Temperature	Part Number		Marking ID		Packing Type
		Pb-free	Halogen-free	Pb-free	Halogen-free	
DIP-16	-10°C~70°C	SDC2921AZ -E1	SDC2921AZ -G1	SDC2921	SDC2921G	Tube
		SDC2921BZ -E1	SDC2921BZ -G1	SDC2921	SDC2921G	Tube

Absolute Maximum Ratings (NOTE: Stresses greater than those listed under Absolute Maximum Ratings may cause permanent damage to the device.)

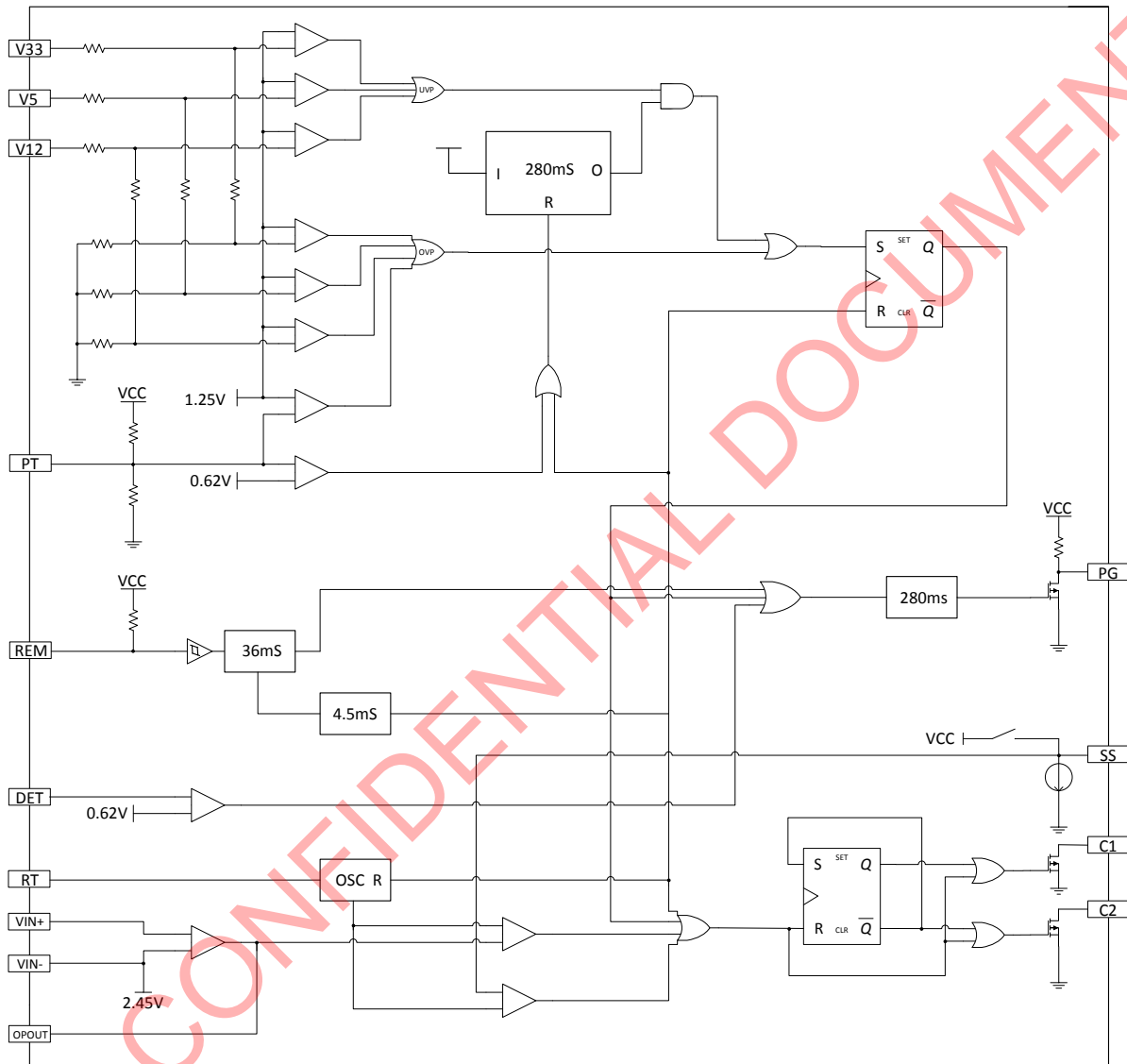
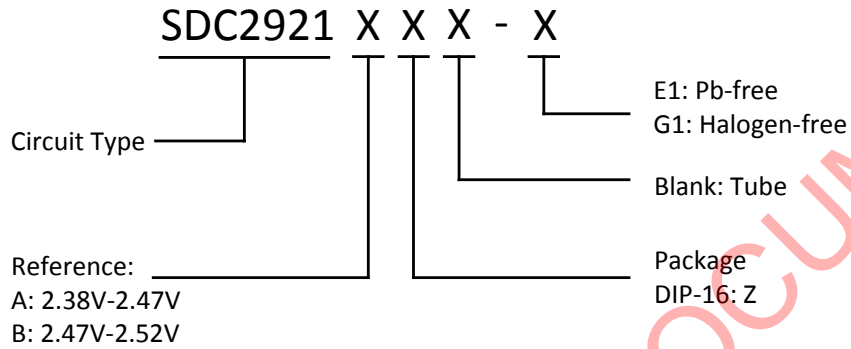
Parameter	Symbol	Value	Unit
Supply voltage	V_{CC}	5.5	V
Drain output voltage	V_{CC1}, V_{CC2}	5.5	V
Drain output current	I_{CC1}, I_{CC2}	200	mA
Power dissipation	P_d	200	mW
Storage temperature	T_{STG}	-65~150	°C
ESD, HBM model per Mil-Std-883, Method 3015	HBM	2000	V
ESD, MM model per JEDEC EIA/JESD22-A115	MM	200	V

Table 2. Absolute Maximum Ratings

Recommended Operating Conditions

Parameter	Symbol	Min	Max	Unit
Supply voltage	V_{CC}	4.5	5.5	V
Oscillation frequency	f_{OSC}	55	65	kHz
Operating temperature	T_{OPR}	-10	70	°C

Table 3. Recommended Operating Conditions

Electrical Characteristics (Ta=25°C, V_{CC}=5.0V, unless otherwise specified)

Parameter	Symbol	Conditions	Min	Typ	Max	Unit
Dead Time Control Section						
Input threshold voltage 1	V _{THDT}	Zero duty cycle	-	3.0	3.3	V
Input threshold voltage 2		Max duty cycle	-	0.1	-	V
Error Amp Section						
Open loop voltage gain	G _V	0.5V~3.5V	-	65	-	dB
Cross over point	B _G	0dB	1800	2200	2600	kHz
VIN- bias voltage(SDC2921A)	V _N	VIN- open	2.38	-	2.47	V
VIN- bias voltage(SDC2921B)	V _N	VIN- open	2.47	-	2.52	V
Output Section						
Output saturation voltage	V _{DSSAT}	I _C =100mA	-	1.0	1.3	V
Drain off-state current	I _{DOFF}	V _{CC} =V _S =V _D =0V	-	2	10	uA
Rising time	t _r	-	-	100	200	ns
Falling time	t _f	-	-	50	200	ns
Protection Section						
3.3V OVP	V33 _{OVP}	-	3.8	4.1	4.3	V
5V OVP	V5 _{OVP}	-	5.8	6.2	6.6	V
12V OVP	V12 _{OVP}	-	4.41	4.64	4.90	V
PT OVP	VPT _{OVP}	-	1.2	1.25	1.3	V
3.3V UVP	V33 _{UVP}	-	1.78	1.98	2.18	V
5V UVP	V5 _{UVP}	-	2.70	3.00	3.30	V
12V UVP	V12 _{UVP}	-	2.11	2.37	2.63	V
UVP disable voltage	VPT _{DIS}	-	0.55	0.62	0.68	V
UVP delay time	t _{UVP}	-	100	280	500	ms
Remote On/Off Section						
Rem high input voltage	V _{REMH}	-	2.0	-	-	V
Rem low input voltage	V _{REML}	-	-	-	0.8	V
Rem pull high voltage	V _{REMO}	-	2.0	-	5.25	V
Rem on delay time	t _{REMON}	-	30	36	42	ms
Rem off delay time	t _{REMOFF}	-	3.5	4.5	5.5	ms

Parameter	Symbol	Conditions	Min	Typ	Max	Unit
Power Good Section						
Detecting input voltage	V_{DET}	-	0.55	0.62	0.68	V
PG output pull-up resistor	R_{PUP}	-	-	5	-	k Ω
PG output load resistor	R_{PG}	-	0.5	1	2	k Ω
PG delay time	t_{PG}	-	100	280	350	ms
PG output saturation voltage	V_{SATPG}	$I_{PG}=10mA$	-	0.2	0.4	V
Soft Start Section						
Sink current of SS	$I_{SS.SINK}$	-	-	13	-	μA
Source current of SS	$I_{SS.SOURCE}$	-	-	700	-	μA
Total Device						
Standby supply current	I_{DD}	-	-	10	20	mA
Oscillation Section						
Oscillation frequency	f_{OSC}	$R_T=120k\Omega$	50	-	70	kHz

Table 4. Electrical Characteristics

Function Description
Input impedance

Pin Number	Pin Name	Input impedance
1	V33	47 kΩ
2	V5	73 kΩ
3	V12	47 kΩ
4	PT	TO VCC: 24 kΩ; TO GND: 4.6 kΩ

Table 5. Input impedance

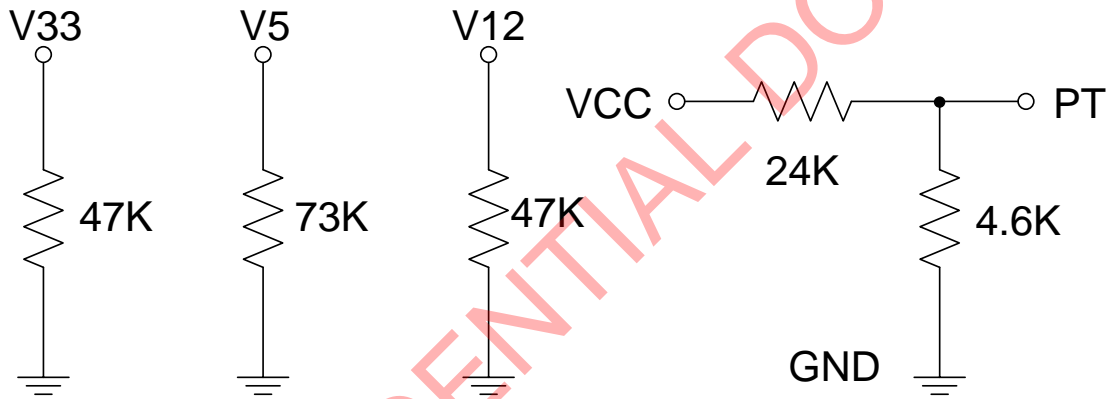

Figure 4. Electrical Characteristics

Sawtooth OSC. Function

Figure 5. Sawtooth OSC. Function

SDC CONFIDENTIAL DOCUMENT

Under Voltage Protection Delay Time

Figure 6. Delay Time

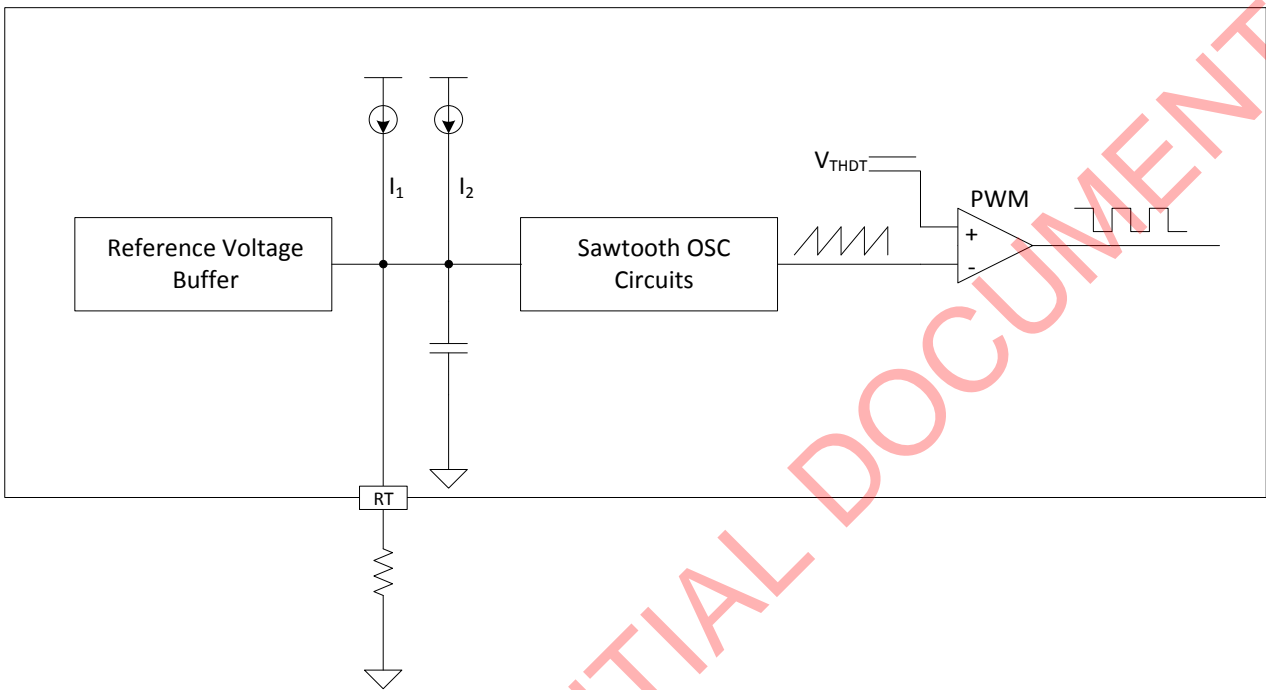
Pulse Width Modulation Block

The output pulse width modulation is generated by comparison of the sawtooth waveform from the capacitor CT to the feedback of the voltage. Therefore, an increase in feedback control signal amplitude cause a linear

decrease of the output pulse width. Also, the SS(Soft-Start) limits the output pulse width. The timing diagram is shown as below:

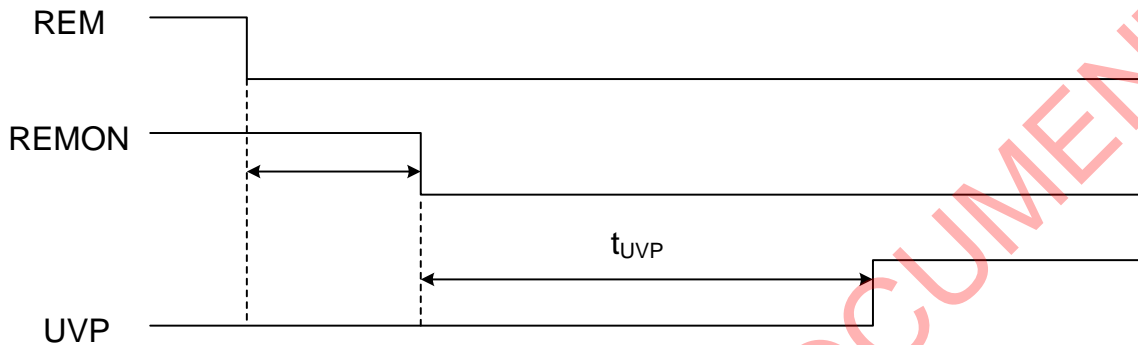
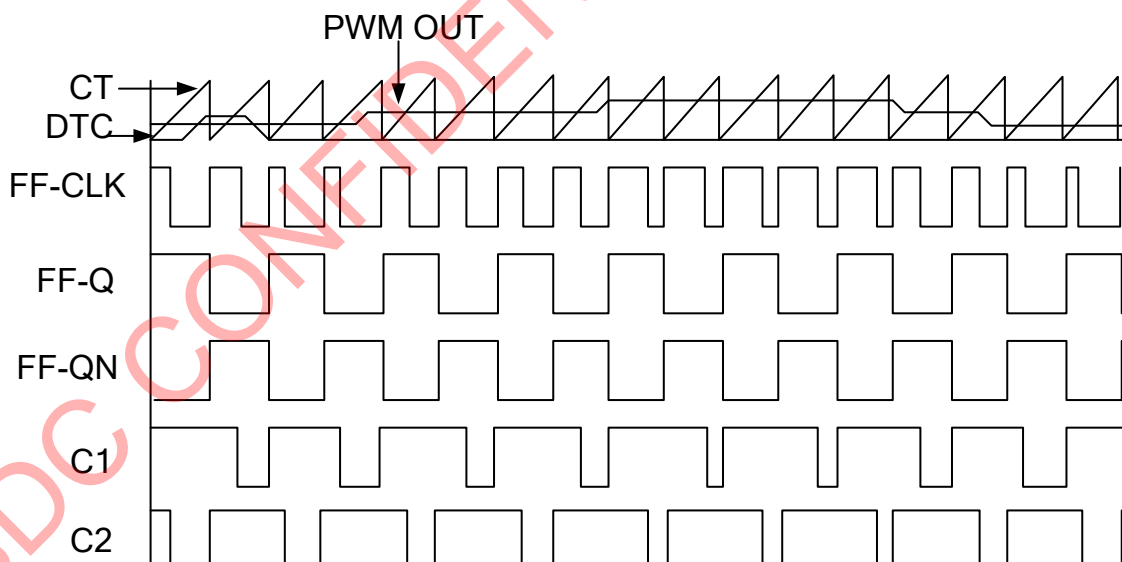

Figure 7. PWM Block

The function of PT

This signal is prepared for extra OVP/OPP ($V_{PT} > 1.25V$) or disable under voltage protection function ($V_{PT} < 0.62V$)

Typical Application

Figure 8. Typical Application

In some application power systems, adding an external resistor (R6) could reduce the peak value spike from the environments to pin 9 (REM) and avoid pin 9 (REM) damaged by the external noise.

Package Dimension
DIP-16

Symbol	Dimensions In Millimeters		Dimensions In Inches	
	Min	Max	Min	Max
A	3.710	4.310	0.146	0.170
A1	0.510	-	0.020	-
A2	3.200	3.600	0.126	0.142
B	0.380	0.570	0.015	0.022
B1	1.524(BSC)		0.060(BSC)	
C	0.204	0.360	0.008	0.014
D	18.800	19.200	0.740	0.756
E	6.200	6.600	0.244	0.260
E1	7.320	7.920	0.288	0.312
e	2.540(BSC)		0.100(BSC)	
L	3.000	3.600	0.118	0.142
E2	8.400	9.000	0.331	0.354

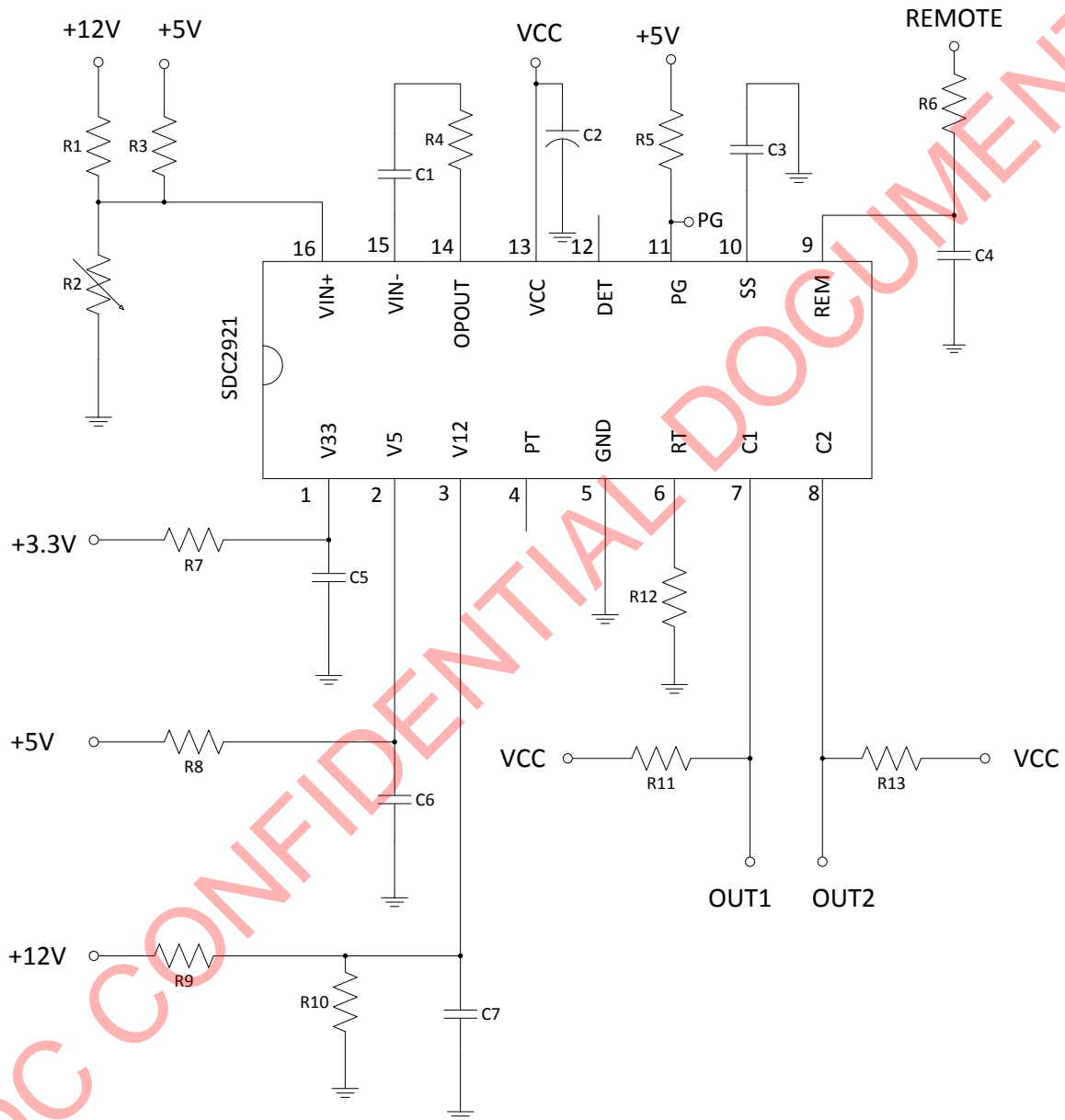
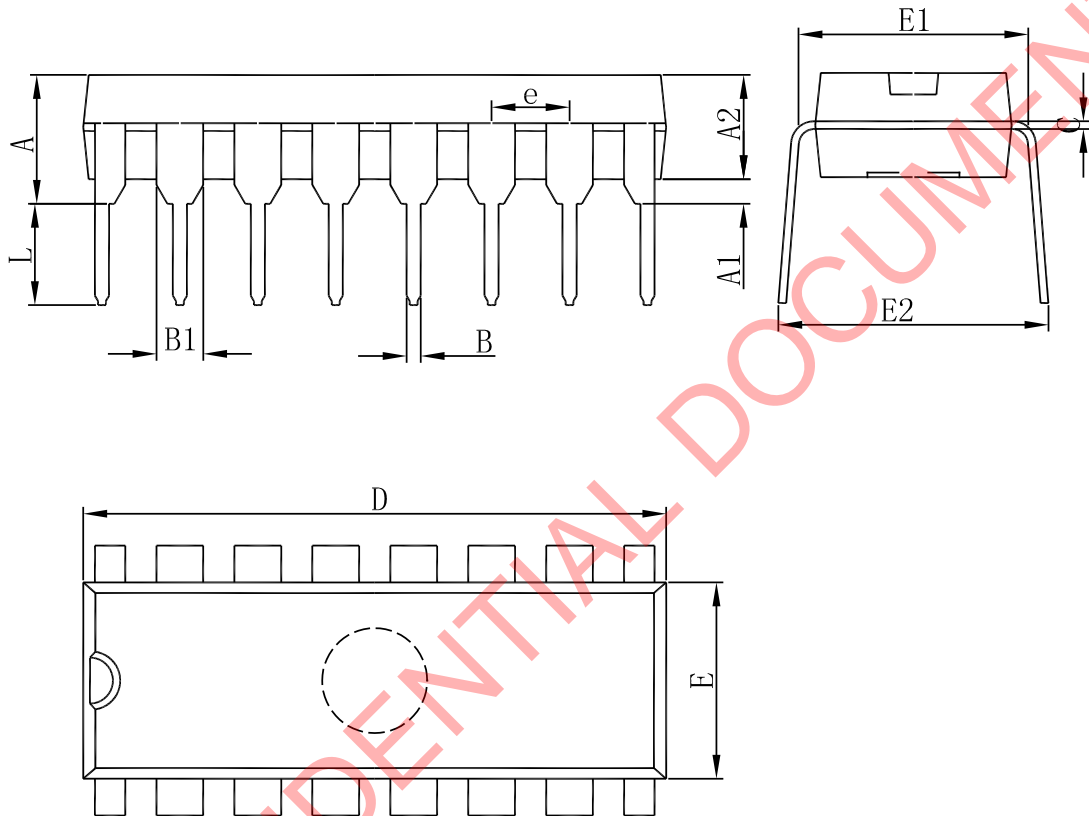

Shaoxing Devechip Microelectronics Co., Ltd.

<http://www.sdc-semi.com/>

IMPORTANT NOTICE

Information in this document is provided solely in connection with Shaoxing Devechip Microelectronics Co., Ltd. (abbr. SDC) products. SDC reserves the right to make changes, corrections, modifications or improvements, to this document, and the products and services described herein at anytime, without notice. SDC does not assume any responsibility for use of any its products for any particular purpose, nor does SDC assume any liability arising out of the application or use of any its products or circuits. SDC does not convey any license under its patent rights or other rights nor the rights of others.

© 2013 Devechip Microelectronics - All rights reserved

Contact us:

Headquarters of Shaoxing
Address: Tian Mu Road, No13,
Shaoxing city, Zhejiang province, China
Zip code: 312000
Tel: (86) 0575-8861 6750
Fax: (86) 0575-8862 2882

Shenzhen Branch
Address: 22A, Shangbu building, Nan Yuan Road, No.68,
Futian District, Shenzhen city, Guangdong province, China
Zip code: 518031
Tel: (86) 0755-8366 1155
Fax: (86) 0755-8301 8528