

## Description

The IDT SGAS711 is a solid-state chemiresistor sensor designed to detect flammable gases in air. The SGAS711 sensor uses an integrated heater with highly sensitive MOx material tailored for detection of flammable gases, such as methane, propane, hydrogen, liquefied petroleum gas (LPG), and more. In addition to detecting flammable gases, the sensor is also sensitive to other hydrocarbons, such as pentane and R410a, and it can be used for leak detection.

The chemiresistor sensors in the IDT SGAS family are based on the principle that metal-oxide materials undergo surface interactions (physisorption and chemisorption) with gas molecules at elevated temperatures, resulting in a measurable change in electrical resistance. As metal-oxide materials are polycrystalline (i.e., composed of multiple grains with distinct grain boundaries), the adsorbed gases have significant electronic effects on the individual grains. These gas-solid interactions result in a change in electron (or hole) density at the surface (i.e., a space charge forms), which in turn changes the electrical conductivity of the oxide. IDT has developed a set of nanostructured gas-sensing materials with excellent sensitivity and stability.

**Figure 1. Product Photo**



## Features

- High sensitivity to a wide range of flammable gases
- Non-specific response; capable of being calibrated to detect a wide range of flammable gases
- Long lifetime (several years in typical applications)
- Typical response time < 30 seconds to 90% of full scale
- Environmental temperature range: -20°C to 50°C
- Minimal response to environmental humidity over the range of 0% to 95%, non-condensing
- Rugged, reliable sensor based on IDT's exclusive technology
- TO-39 package

## Typical Applications

- Leak Detection
- Gas Concentration Detection
- Process Control

## Examples of Target Gases

- Hydrocarbons (HC)
- Hydrogen
- Liquid Petroleum Gas (LPG)
- Methane
- Natural Gas
- Propane
- Pentane
- R410a

## Available Support

- Evaluation kit – SMOD711 Smart Sensing Module
- Application notes
- Instruction videos
- Reference designs

## Contents

1. Pin Assignments.....	4
2. Pin Descriptions.....	4
3. Sensor Specifications.....	4
4. Sensor Characteristics.....	5
5. Basic Measurement Circuit.....	6
6. Heater Driver Circuits and Control.....	7
6.1 Constant Voltage Drive.....	7
6.2 Constant Current Drive.....	8
6.3 Pulse-Width Modulation.....	8
6.4 Operating the Sensor at Temperature Extremes.....	9
7. Sensing Characteristics.....	10
7.1 Sensitivity.....	10
7.2 Response and Recovery Time.....	11
7.3 Cross-Sensitivity.....	12
8. Maximum ESD Ratings.....	13
9. Mechanical Stress Testing.....	13
10. Package Drawing and Dimensions.....	14
11. Applications and Use Conditions.....	15
12. Ordering Information.....	15
13. Revision History.....	15

## List of Figures

Figure 1. Product Photo.....	1
Figure 2. Pin Assignments for SGAS711 – Top View.....	4
Figure 3. Typical Sensor Response Characteristic.....	6
Figure 4. Basic Measurement Circuit.....	6
Figure 5. Three Terminal Voltage Regulator.....	7
Figure 6. Voltage-Controlled Constant Current Circuit.....	8
Figure 7. Recommended Applied Heater Voltage as a Function of Environmental Temperature.....	9
Figure 8. Sensor Response to a Variety of Flammable Gases.....	10
Figure 9. Effect of Different Humidity Levels on Sensor Signal at Ambient Temperature.....	11
Figure 10. Typical Sensor Response to Step Changes in Methane Concentration for Seven SGAS711 Sensors.....	11
Figure 11. Typical Sensor Response to other Common Gases.....	12
Figure 12. TO-39 Package (TO4) Outline Drawing PSC-4676.....	14

---

## List of Tables

Table 1.	Pin Descriptions.....	4
Table 2.	Electrical Specifications.....	4
Table 3.	Temperature Specifications.....	5
Table 4.	Maximum ESD Ratings .....	13
Table 5.	Mechanical Stress Test Conditions .....	13

## 1. Pin Assignments

**Figure 2. Pin Assignments for SGAS711 – Top View**

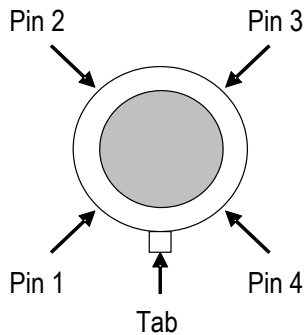

## 2. Pin Descriptions

**Table 1. Pin Descriptions**

Note: See Figure 4 for the connections described below.

Pin Number	Name	Description
1	Heater +	Positive input for $V_H$ heater voltage supply
2	Sensor +	High-side of resistive sensor element; positive input for sensing voltage $V_C$
3	Heater –	Negative input for $V_H$ heater voltage supply (ground)
4	Sensor –	Low-side of resistive sensor element; connects to middle of resistor divider circuit to produce sensing voltage output ( $V_{OUT}$ )

## 3. Sensor Specifications

Note: All measurements were made in dry gas at room temperature. Specifications are subject to change.

**Table 2. Electrical Specifications**

Symbol	Parameter	Conditions	Minimum	Typical	Maximum	Units
$P_H$	Heater Power Consumption	$V_H = 7.0V$		900		mW
$V_H$	Recommended Heater Voltage	$T_{SENSOR} = 300^{\circ}C$		7.0		VDC
$R_H$	Heater Resistance	At room temperature	28	30	32	$\Omega$
$V_C$	Recommended Sensing Voltage		2.5		5.0	VDC
$R_{1000}$	Resistance at 1000ppm Methane ( $CH_4$ )		10		1000	k $\Omega$
$R_{1000}/R_{2500}$	Resolution: Resistance in 1000ppm/ Resistance in 2500ppm		1.2			

**Table 3. Temperature Specifications**

Symbol	Parameter	Conditions	Minimum	Typical	Maximum	Units
T <sub>OP</sub>	Sensor Operation Temperature	V <sub>H</sub> = 7.0V		300		°C
T <sub>AMB</sub>	Recommended Environmental Temperature Range		-20		50	°C
T <sub>STOR</sub>	Maximum Storage Temperature Range		-50		125	°C

The sensor is not intended for continuous operation above or below the environmental temperature specification, but exposure for short durations will not will not harm the sensor.

## 4. Sensor Characteristics

IDT's solid-state chemiresistive sensors are an advanced type of gas-sensitive resistor; i.e. they sense the presence of a target gas through a change in resistance of the sensing element. Most sensors exhibit reduced resistance as gas concentration increases, typically over several orders of magnitude across the sensing range.

Solid-state chemiresistive sensors show a reduced resistance with increasing gas concentration according to Equation 1:

$$R_S = A * C^{-\alpha} \quad \text{Equation 1}$$

where  $R_S$  is resistance,  $C$  is concentration, and  $A$  and  $\alpha$  are constants. Although several refined versions of this equation are available for specific sensors or sensing materials, the fundamental resistance versus concentration relationship for all of IDT's n-type sensors follows Equation 1. Taking the log of both sides of the equation results in Equation 2:

$$\log(R_S) = \log(A) - \alpha * \log(C) \quad \text{Equation 2}$$

This shows that log resistance versus log concentration is linear.

An immediately observable consequence of Equation 1 is that sensor resistance will change rapidly at low concentrations and much less at high concentrations. This is illustrated in the following example:

$$\begin{aligned} R_{GAS\_10ppm} &= 20k\Omega \\ R_{GAS\_100ppm} &= 5k\Omega \\ A_{GAS} &= 8.0 * 10^4 \\ \alpha_{air} &= 0.602 \end{aligned}$$

The non-logarithmic response plot shown in Figure 3 illustrates the fundamental challenge that must be addressed when measuring the resistance of chemiresistor sensors and relating these measurements to gas concentrations. Additional non-linear effects from measurement circuitry exacerbate these challenges and must be understood in order to account for or eliminate these effects.

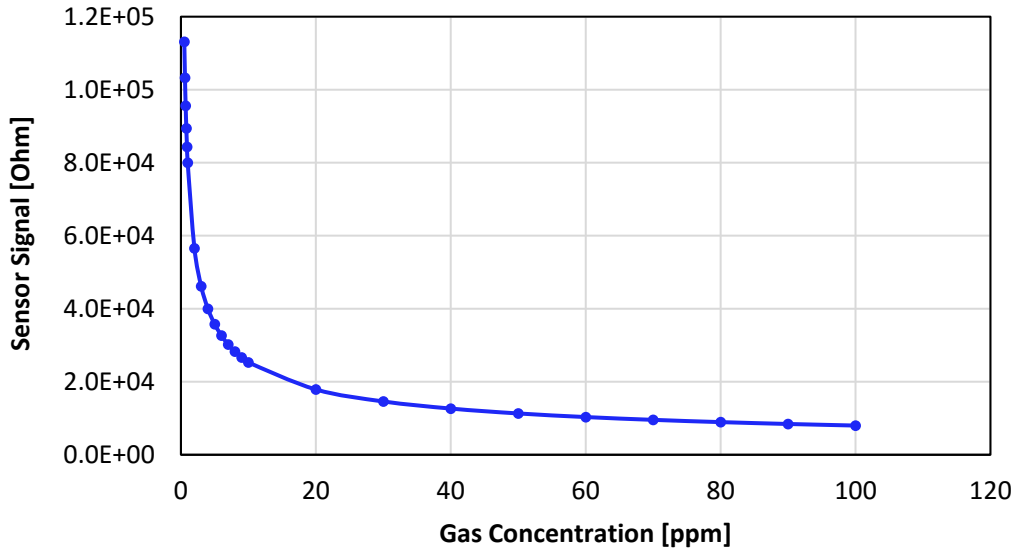
**Figure 3. Typical Sensor Response Characteristic**

The electronic instrumentation used to detect this change in resistance influences the quality and accuracy of the gas sensing result. In particular, the choice of the analog front-end used to measure resistance can ultimately have a significant effect on overall measurement characteristics and must be selected with care. For additional information, see IDT's *Application Note – Resistance Measuring Circuits for SGAS Sensors*.

## 5. Basic Measurement Circuit

The sensor can be operated using a simple voltage divider. This requires two voltage supplies: heater voltage ( $V_H$ ) and circuit voltage ( $V_C$ ).  $V_H$  is applied to the heater in order to maintain a constant, elevated temperature for optimum sensing.  $V_C$  is applied to allow a measurement of the output voltage ( $V_{OUT}$ ) across a load resistor ( $R_L$ ).

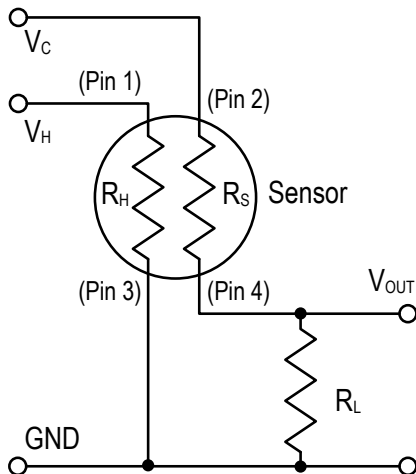
**Figure 4. Basic Measurement Circuit**

Pins 1 and 3 are attached to the heater. Apply  $V_H$  across these pins. Pins 2 and 4 are attached to the resistive sensor element. Connect these pins in the measurement circuit. IDT supplies basic measurement circuitry for many of our sensors. More information can be found in IDT's *Application Note – Resistance Measuring Circuits for SGAS Sensors*.

## 6. Heater Driver Circuits and Control

This sensor contains a resistive element that is used to heat the sensor to the target operating temperature as shown in Table 3. The SGAS711 sensor uses a thermistor heater element with a positive temperature coefficient, i.e. the heater resistance increases from the cold (room temperature) resistance as power is applied. This provides the opportunity for constant power and constant resistance (closely related to constant temperature) control of the heater.

### 6.1 Constant Voltage Drive

The simplest method of applying heater power is the use of a *constant voltage drive*. Because heaters draw a relatively large amount of current in normal operation, some method of current amplification is required. Additionally, because relatively small changes in voltage levels will affect the temperature of the heater (and consequently gas sensitivity), voltage regulation is required.

An easily implemented control circuit utilizes a three terminal voltage regulator, with the LM317 serving as an example as shown in Figure 5.

**Figure 5. Three Terminal Voltage Regulator**

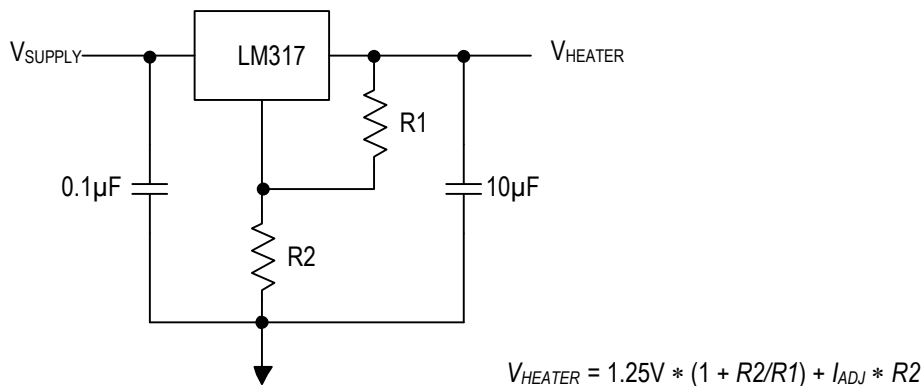

R1 and R2 (one of which can be a potentiometer) are selected to provide the target heater drive voltage for the sensor. The example for the LM317 is capable of regulating voltages down to 1.25V and is thus suitable for SGAS711 sensors. However, a wide variety of more advanced three terminal voltage regulators is available from component manufacturers.

Constant voltage circuits of this type are relatively efficient, particularly if a switching regulator is used. Adding external control of the regulator output voltage with a current sensing resistor would allow feedback control of the sensor heater power and temperature, but the required circuitry is somewhat complex. Applications requiring feedback control are better implemented with the constant current circuit that is described in section 6.2.

## 6.2 Constant Current Drive

The *constant current drive* is more complex and costly than the constant voltage drive, but the added capabilities justify the expense for many applications. Additionally, the circuit is “microcontroller friendly” because the heater current is directly controllable via an input voltage signal, and feedback control of the heater is possible through a simple measurement of the resultant voltage on the heater.

The constant current heater drive circuit is shown in Figure 6.  $V_{IN}$  (supplied by an external source) is forced across  $R1$ , thus providing a predictable current through both  $R1$  and  $R2$ , along with a predictable voltage drop (relative to  $V_{DD}$ ) across  $R2$ . An equivalent drop is imposed across  $R3$ , and the current through both  $R3$  and  $R_{HEATER}$  is thus controlled independently of the load resistance according to the equation in Figure 6.

The heater current is controllable to below 1mA. However, the circuit is inefficient compared to others, as power is dissipated in  $R3$  and  $Q2$  as well as the heater. Limiting the supply voltage to several hundred mV above the highest required drive voltage will help increase circuit efficiency.

While  $V_{in}$  can be supplied by a fixed voltage reference (such as a divider), the flexibility of the circuit is most revealed when  $V_{IN}$  is supplied by a microcontroller via a digital-to-analog converter (DAC). With this type of control, the heater drive can be time programmed to allow pulsing of the heater with variable amplitude. Determination of heater power or resistance is possible by reading the voltage level at the heater. Since the heater temperature directly correlates with heater resistance, direct feedback control of bulk heater temperature is possible by raising or lowering the heater current such that  $V_{HEATER}/I_{HEATER}$  is constant. Likewise, constant heater power can be maintained by controlling current to keep  $V_{HEATER} * I_{HEATER}$  constant.

**Figure 6. Voltage-Controlled Constant Current Circuit**

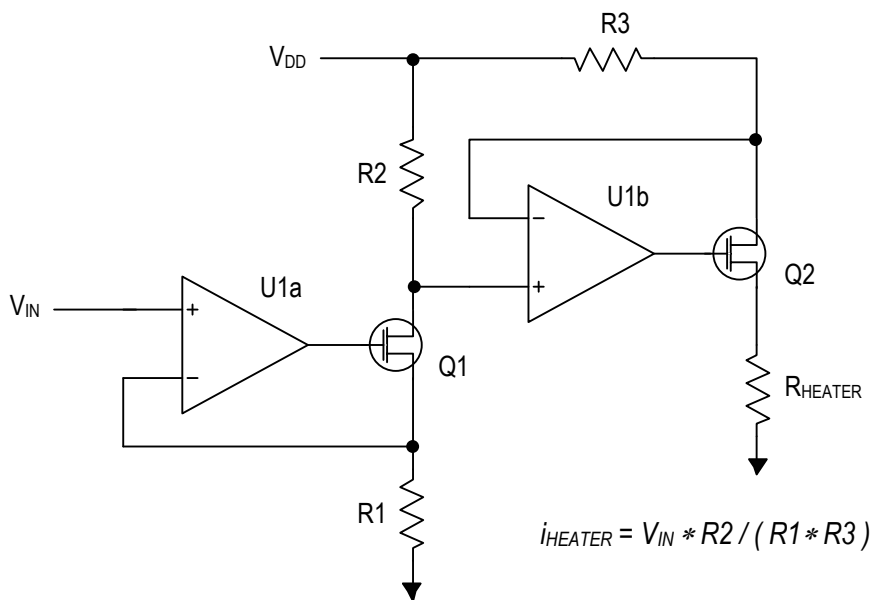

## 6.3 Pulse-Width Modulation

Pulse-width modulation (PWM) is a very efficient method of providing controllable drive to the heater. However, this method has not undergone sufficient testing at IDT to allow us to recommend it for any sensors in the SGAS family.

PWM heater drive design should keep the following in mind:

- Voltage to the heater should not exceed the maximum voltage allowed for a given heater family.
- A low-pass filter should be considered as part of the sensor signal circuit path to reduce noise from heater PWM.



## 6.4 Operating the Sensor at Temperature Extremes

When this sensor is used outdoors, the relative response of the sensor to the target gases will be a function of environmental temperature when the sensor is operated with a constant voltage or current applied to the heater. This behavior is readily explained by considering that large shifts in ambient temperatures affect the operating temperature at the sensor surface, in turn altering the kinetics and thermodynamics of the interaction of the sensing surface with flammable gases. This alters the electrical conduction of the sensor element (the basis of metal-oxide sensor operation). In these cases, it is recommended to operate the sensor in a feedback loop, where constant resistance at the heater is maintained. For operation in ambient conditions above  $T_{AMB} = 50^{\circ}\text{C}$ , additional compensation of the sensor signal may be required and should be developed by the user with the specific application and operating conditions in mind. A graphical representation of the recommended temperature set point voltage versus environmental temperature is shown in Figure 7.

The mathematical description for the curve is given in Equation 3:

$$V_H = -0.01 * \text{Environmental Temperature } [^{\circ}\text{C}] + 7.2$$

Equation 3

**Figure 7. Recommended Applied Heater Voltage as a Function of Environmental Temperature**

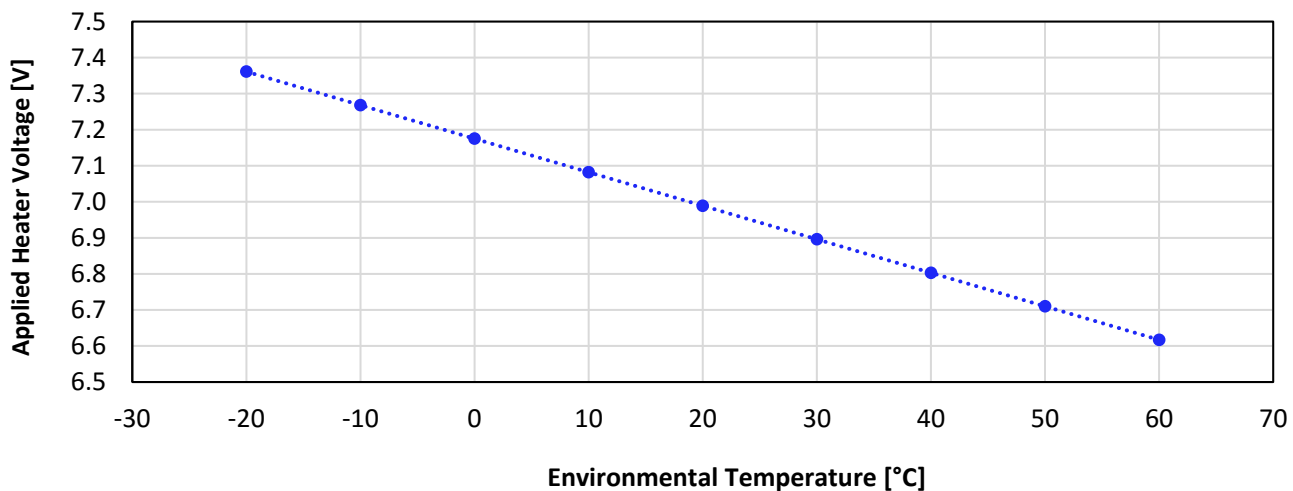

## 7. Sensing Characteristics

The following graphs show the typical responses that are to be expected from the sensors upon exposure to a variety of test conditions. For sensor specifications, refer to Table 2.

### 7.1 Sensitivity

The typical sensitivity of the SGAS711 sensor to a range of flammable gases is shown in Figure 8. Sensitivity is defined as the ratio between the resistance in air ( $R_{Air}$ ) and the resistance in gas ( $R_{Gas}$ ).

**Figure 8. Sensor Response to a Variety of Flammable Gases**

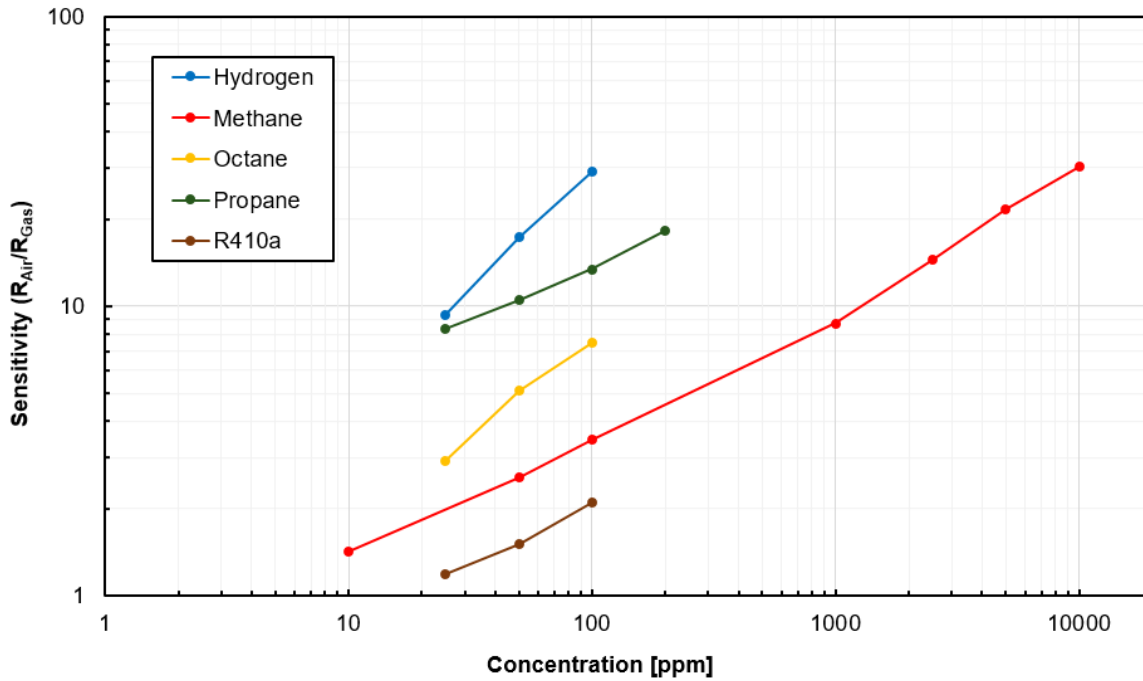

The typical response of the sensor to changes in humidity is shown in Figure 9.

**Figure 9. Effect of Different Humidity Levels on Sensor Signal at Ambient Temperature**

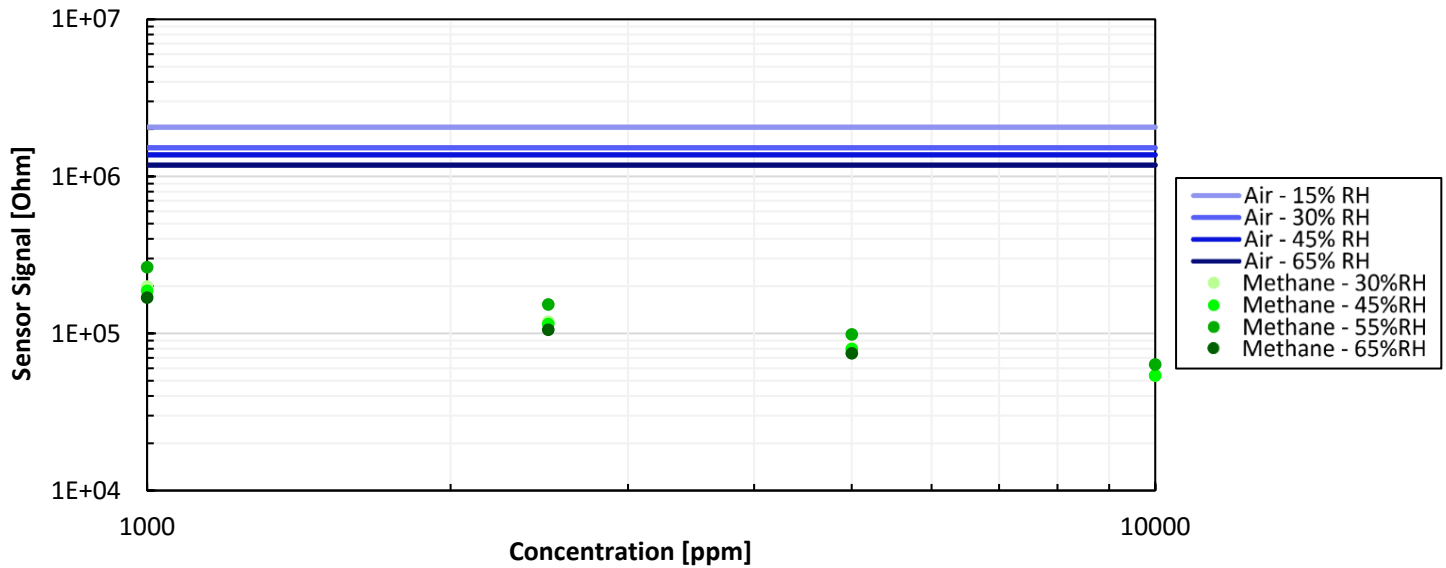

## 7.2 Response and Recovery Time

The typical response and recovery time of seven sensors is shown in Figure 10. The response and recovery time can be strongly affected by the sensor location within the system, including any barriers to diffusion of gas to and from the sensor surface and whether the sensor is operated with or without a pump or other source of external flow.

**Figure 10. Typical Sensor Response to Step Changes in Methane Concentration for Seven SGAS711 Sensors**

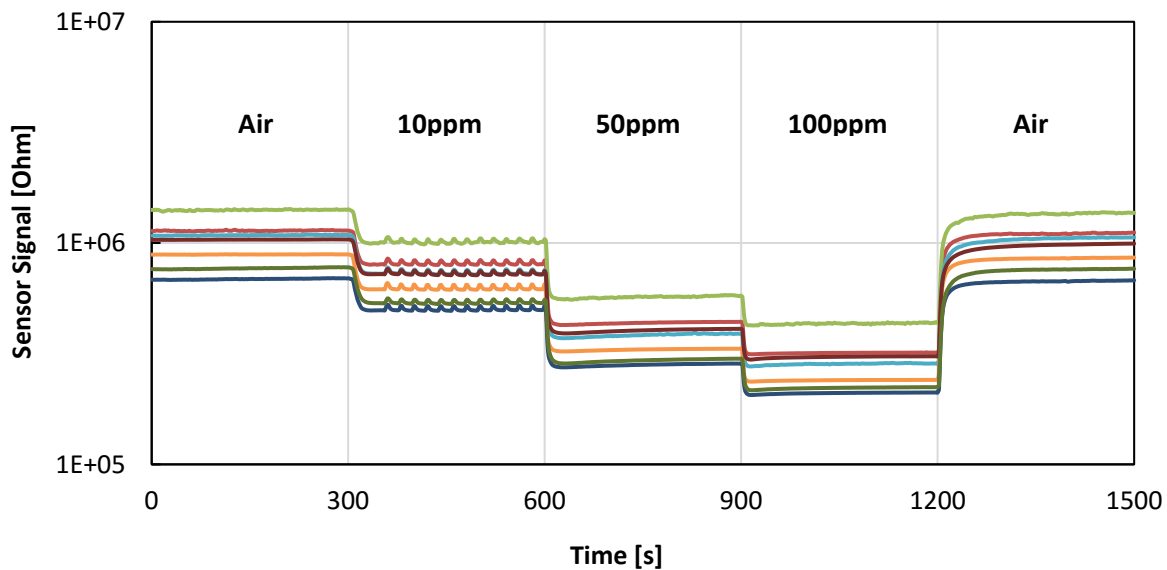

### 7.3 Cross-Sensitivity

The response of the SGAS711 sensors to a range of other common gases is shown in Figure 11.

**Figure 11. Typical Sensor Response to other Common Gases**

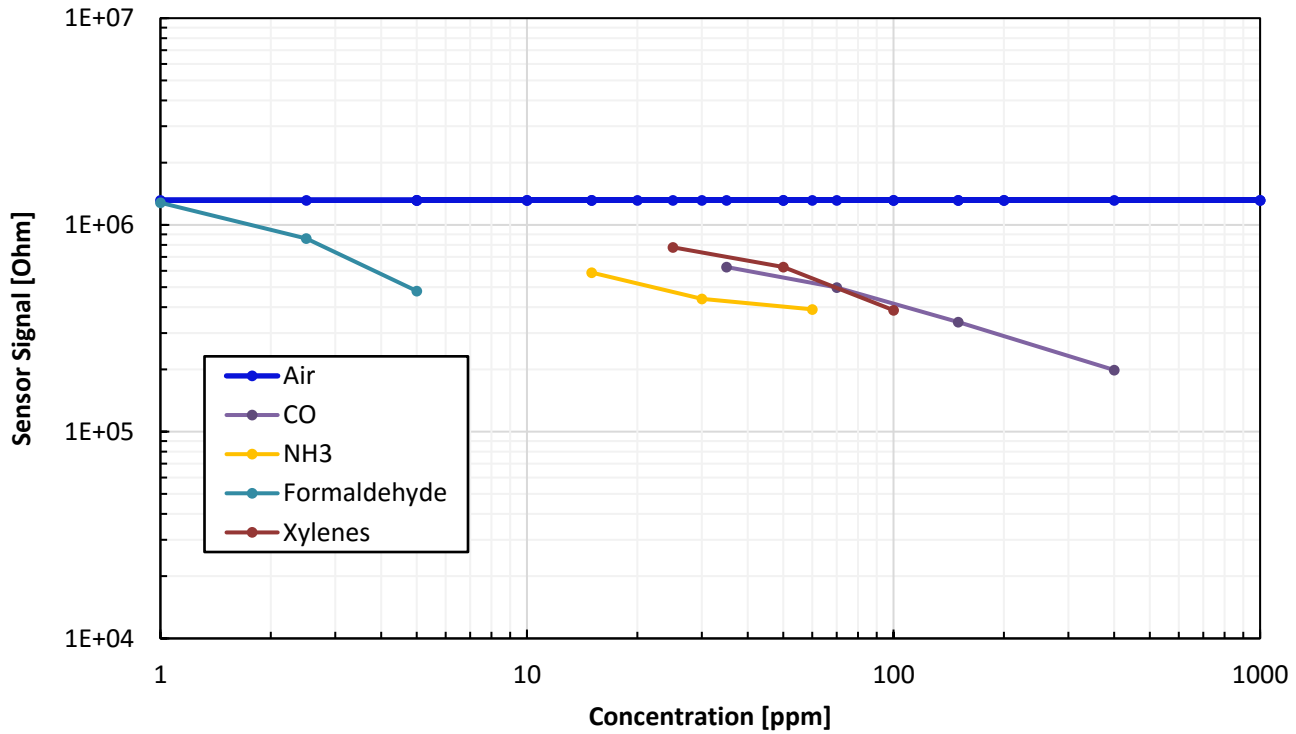

## 8. Maximum ESD Ratings

**Table 4. Maximum ESD Ratings**

Symbol	Parameter	Conditions	Minimum	Maximum	Units
V <sub>HBM1</sub>	Electrostatic Discharge Tolerance – Human Body Model (HBM1)		2000	–	V
V <sub>CDM</sub>	Electrostatic Discharge Tolerance – Charged Device Model (CDM) on Packaged Module		500	–	V

## 9. Mechanical Stress Testing

The qualification of the SGAS711 is based on the JEDEC standard (JESD47).

After subjection to the mechanical shock and vibration testing conditions given in Table 5, the SGAS711 sensor will meet the specifications given in this document. For information on constant acceleration test conditions and limits, contact IDT (see contact information on last page).

**Table 5. Mechanical Stress Test Conditions**

Stress Test	Standard	Conditions
Mechanical Shock	JESD22-B104, M2002	Y1 plane only, 5 pulses, 0.5ms duration, 1500g peak acceleration
Vibration Variable Frequency	JESD22-B103, M2007	20Hz to 2kHz (log variation) in > 4 minutes, 4 times in each orientation, 50g peak acceleration

# 10. Package Drawing and Dimensions

Figure 12. TO-39 Package (TO4) Outline Drawing PSC-4676

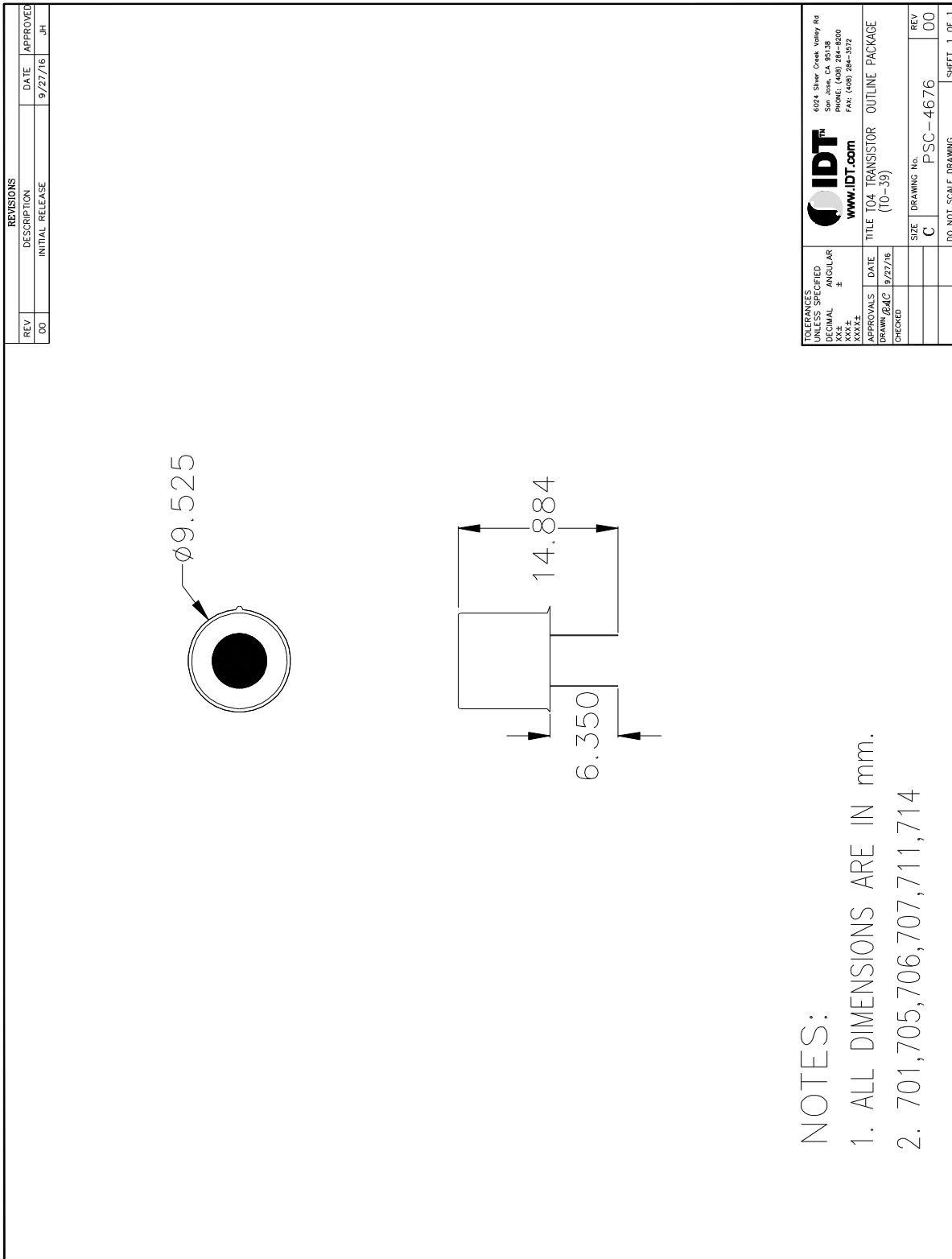

## 11. Applications and Use Conditions

The SGAS711 sensor is designed for gas leak detection and measurement of ppm levels of flammable gases. The sensor is not intended, recommended, or approved for use in safety or life-protecting applications or in potentially explosive environments. IDT disclaims all liability for such use. For sensor storage, IDT strongly recommends a dust and VOC free atmosphere, e.g. in synthetic air.

## 12. Ordering Information

Orderable Part Number	Description and Package	MSL Rating	Shipping Packaging	Temperature
SGAS711	4-pin TO-39 (TO4)	1	Tray	-20°C to +50°C
SMOD711KITV1	SMOD711 Evaluation Kit, including the SMOD711 Smart Sensing Module (includes the SGAS711 sensor), mini-USB cable, and wall-mounted 9V power supply. The <i>SMOD7xx Application Software</i> is available for download at <a href="http://www.idt.com/SMOD711">www.idt.com/SMOD711</a> .			

## 13. Revision History

Revision Date	Description of Change
October 24, 2017	Full revision.
November 4, 2016	Changed to IDT branding.



### Corporate Headquarters

6024 Silver Creek Valley Road  
San Jose, CA 95138  
[www.IDT.com](http://www.IDT.com)

### Sales

1-800-345-7015 or 408-284-8200  
Fax: 408-284-2775  
[www.IDT.com/go/sales](http://www.IDT.com/go/sales)

### Tech Support

[www.IDT.com/go/support](http://www.IDT.com/go/support)

DISCLAIMER Integrated Device Technology, Inc. (IDT) and its affiliated companies (herein referred to as "IDT") reserve the right to modify the products and/or specifications described herein at any time, without notice, at IDT's sole discretion. Performance specifications and operating parameters of the described products are determined in an independent state and are not guaranteed to perform the same way when installed in customer products. The information contained herein is provided without representation or warranty of any kind, whether express or implied, including, but not limited to, the suitability of IDT's products for any particular purpose, an implied warranty of merchantability, or non-infringement of the intellectual property rights of others. This document is presented only as a guide and does not convey any license under intellectual property rights of IDT or any third parties.

IDT's products are not intended for use in applications involving extreme environmental conditions or in life support systems or similar devices where the failure or malfunction of an IDT product can be reasonably expected to significantly affect the health or safety of users. Anyone using an IDT product in such a manner does so at their own risk, absent an express, written agreement by IDT.

Integrated Device Technology, IDT and the IDT logo are trademarks or registered trademarks of IDT and its subsidiaries in the United States and other countries. Other trademarks used herein are the property of IDT or their respective third party owners. For datasheet type definitions and a glossary of common terms, visit [www.idt.com/go/glossary](http://www.idt.com/go/glossary). All contents of this document are copyright of Integrated Device Technology, Inc. All rights reserved.