

HIGH-PERFORMANCE PRODUCTS

Description

The SK10/100E445 is an integrated 4-bit serial-to-parallel data converter. The device is designed to operate for NRZ data rates of up to 2.0 Gb/s. The chip generates a divide by 4 and a divide by 8 clock for both 4-bit conversion and a two chip 8-bit conversion function. The conversion sequence was chosen to convert the first serial bit to Q0, the second to Q1, etc.

The start bit for conversion can be moved using the SYNC input. A single pulse applied asynchronously for at least two input clock cycles shifts the start bit for conversion from Qn to Qn-1. For each additional shift required, an additional pulse must be applied to the SYNC input. Asserting the SYNC input will force the internal clock dividers to "swallow" a clock pulse, effectively shifting a bit from the Qn to the Qn-1 output (see Timing Diagram B).

The MODE input is used to select the conversion mode of the device. With the MODE input LOW, or open, the device will function as a 4-bit converter. When the MODE input is driven HIGH, the data on the output will change on every eighth clock cycle, thus allowing for an 8-bit conversion scheme using two E445's. When cascaded in an 8-bit conversion scheme, the devices will not operate at the 2.0 Gb/s data rate of a single device. Refer to the applications section of this data sheet for more information on cascading the E445.

For lower data rate applications, a V_{BB} reference voltage is supplied for single-ended inputs. When operating at clock rates above 500 MHz, differential input signals are recommended. For single-ended inputs, the V_{BB} pin is tied to the inverting differential input and bypassed via a 0.01 μF capacitor. The V_{BB} provides the switching reference for the input differential amplifier. The V_{BB} can also be used to AC couple an input signal.

Upon power-up, the internal flip-flops will attain a random state. To synchronize multiple E445's in a system, the master reset must be asserted.

Features

- Extended 100E VEE Range of -4.2V to -5.5V
- On-Chip Clock ÷ 4 and ÷ 8
- 2.0 Gb/s Data Rate Capability
- Differential Clock and Serial Inputs
- V_{BB} Output for Single-Ended Input Applications
- Asynchronous Data Synchronization
- Mode Select to Expand to 8-Bits
- Internal 75KΩ Input Pulldown Resistors
- ESD Protection of >4000V
- Fully Compatible with MC10/100E445
- Available in 28-Pin PLCC Package

Functional Block Diagram

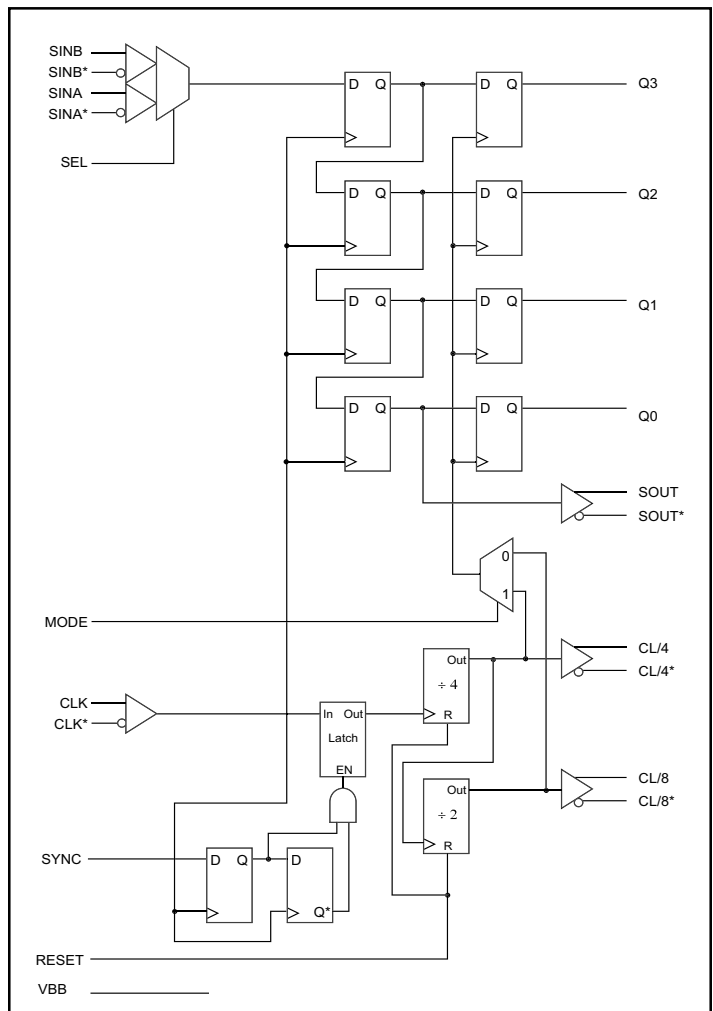

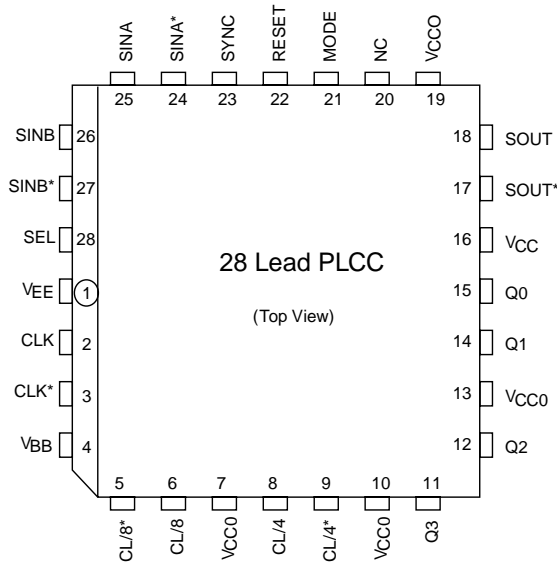
Pinout

Pin Names

Pin	Function
SINA, SINA*	Differential Serial Data Input A
SINB, SINB*	Differential Serial Data Input B
SEL	Serial Input Selector Pin
Q0 - Q3	Parallel Data Outputs
SOUT, SOUT*	Differential Serial Data Output
CLK, CLK*	Differential Clock Inputs
CL/4, CL/4*	Differential +4 Clock Output
CL/8, CL/8*	Differential +8 Clock Output
MODE	Conversion Mode 4-Bit/8-Bit
SYNC	Conversion Synchronizing Input
VBB	Reference Output Voltage
Vcc, Vcco	Positive Supply
VEE	Negative Supply
NC	No Connect

Function Table

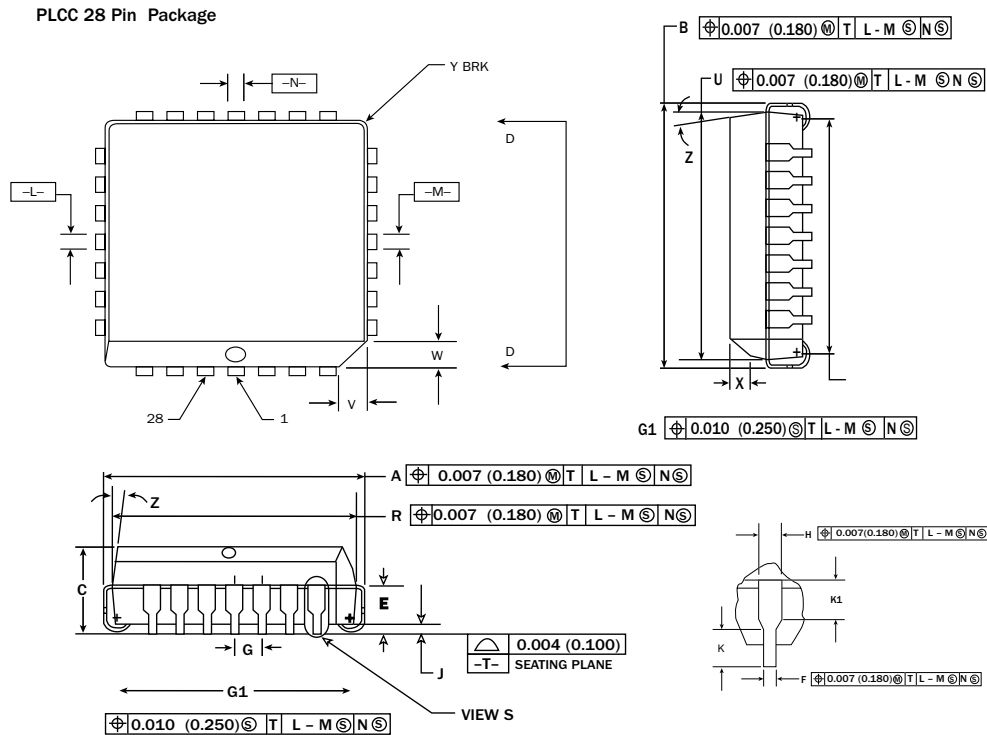
Mode	Conversion	SEL	Serial Input
L	4-Bit	H	A
H	8-Bit	L	B



NOTES:

1. Datums -L-, -M-, and -N- determined where top of lead shoulder exits plastic body at mold parting line.
2. DIM G1, true position to be measured at Datum -T-, Seating Plane.
3. DIM R and U do not include mold flash. Allowable mold flash is 0.010 (0.250) per side.
4. Dimensioning and tolerancing per ANSI Y14.5M, 1982.
5. Controlling Dimension: Inch.
6. The package top may be smaller than the package bottom by up to 0.012 (0.300). Dimensions R and U are determined at the outermost extremes of the plastic body exclusive of mold flash, tie bar burrs, gate burrs and interlead flash, but including any mismatch between the top and bottom of the plastic body.
7. Dimension H does not include Dambar protrusion or intrusion. The Dambar protrusion(s) shall not cause the H dimension to be greater than 0.037 (0.940). The Dambar intrusion(s) shall not cause the H dimension to be smaller than 0.025 (0.635).

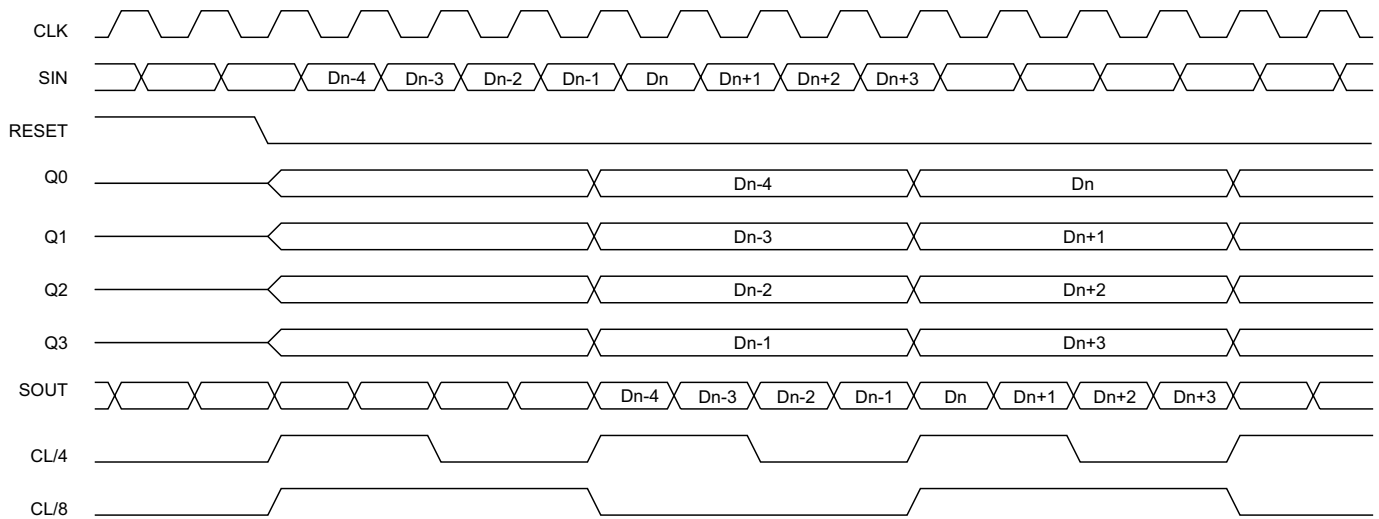
DIM	INCHES		MILLIMETERS	
	MIN	MAX	MIN	MAX
A	0.485	0.495	12.32	12.57
B	0.485	0.495	12.32	12.57
C	0.165	0.180	4.20	4.57
E	0.090	0.110	2.29	2.79
F	0.013	0.019	0.33	0.48
G	0.050 BSC		1.27 BSC	
H	0.026	0.032	0.66	0.81
J	0.020	-	0.51	-
K	0.025	-	0.64	-
R	0.450	0.456	11.43	11.58
U	0.450	0.456	11.43	11.58
V	0.042	0.048	1.07	1.21
W	0.042	0.048	1.07	1.21
X	0.042	0.056	1.07	1.42
Y	-	0.020	-	0.50
Z	2°	10°	2°	10°
G1	0.410	0.430	10.42	10.92
K1	0.040	-	1.02	-

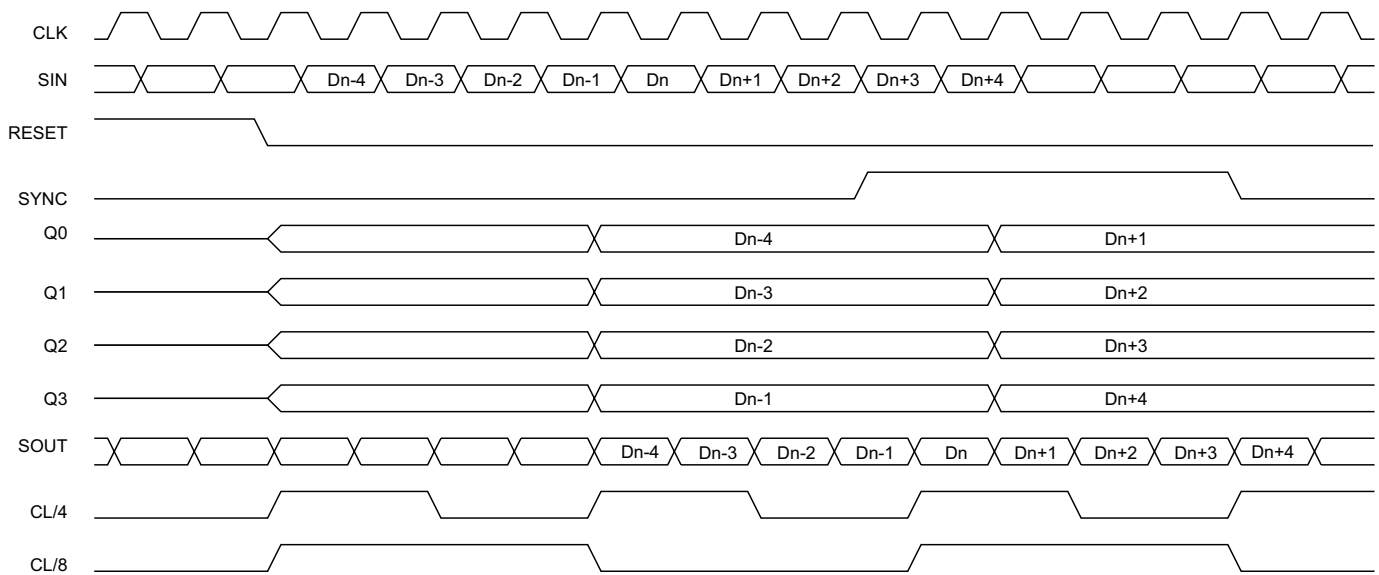

Timing Diagram A. 1:4 Serial to Parallel Conversion



Timing Diagram B. 1:4 Serial to Parallel Conversion with SYNC Pulse

HIGH-PERFORMANCE PRODUCTS
DC Characteristics
SK10E445 DC Electrical Characteristics
(VCC - VEE = 4.2V to 5.5V; VCC = VCC0; VOUT Loaded 50 Ω to VCC - 2.0V)

Symbol	Characteristic	TA = - 40°C			TA = 0°C			TA = +25°C			TA = +85°C			Unit
		Min	Typ	Max	Min	Typ	Max	Min	Typ	Max	Min	Typ	Max	
I _{IN}	Input Current (Diff) (SE)	-150		150 150	-150		150 150	-150		150 150	-150		150 150	μA μA
V _{BB}	Reference Output Voltage	-1.43		1.3	-1.38		-1.27	-1.35		-1.25	-1.31		-1.19	V
I _{EE}	Power Supply Current		154	185		154	185		154	185		154	185	mA

SK100E445 DC Electrical Characteristics
(VCC - VEE = 4.2V to 5.5V; VCC = VCC0; VOUT Loaded 50 Ω to VCC - 2.0V)

Symbol	Characteristic	TA = - 40°C			TA = 0°C			TA = + 25°C			TA = + 85°C			Unit
		Min	Typ	Max	Min	Typ	Max	Min	Typ	Max	Min	Typ	Max	
I _{IN}	Input Current (Diff) (SE)	-150		150 150	-150		150 150	-150		150 150	-150		150 150	μA μA
V _{BB}	Reference Output Voltage	-1.38		-1.26	-1.38		-1.26	-1.38		-1.26	-1.38		-1.26	V
I _{EE}	Power Supply Current		154	185		154	185		154	185		154	185	mA

HIGH-PERFORMANCE PRODUCTS
AC Characteristics
SK10/100E445 AC Electrical Characteristics
(VCC - VEE = 4.2V to 5.5V; VCC = VCC0; VOUT Loaded 50 Ω to VCC - 2.0V)

Symbol	Characteristic	TA = - 40°C			TA = 0°C			TA = + 25°C			TA = + 85°C			Unit
		Min	Typ	Max	Min	Typ	Max	Min	Typ	Max	Min	Typ	Max	
f _{max}	Max Conversion Frequency	2.0			2.0			2.0			2.0			GB/s NRZ
t _{PLH} t _{PHL}	Propagation Delay to Output CLK to Q0-Q3 CLK to SOUT CLK to CL/4 & CL/8	1200 700 800	1500 800 1050	1800 900 1300	1200 700 800	1500 805 1050	1800 910 1300	1200 700 800	1500 810 1050	1800 920 1300	1200 700 800	1500 850 1050	1800 1000 1300	ps ps ps
t _s	Setup Time SINA, SINB SEL	-100 0	-250 -200		-100 0	-250 -200		-100 0	-250 -200		-100 0	-250 -200		ps ps
t _h	Hold Time SINA, SINB, SEL	450	300		450	300		450	300		450	300		ps
t _{RR}	Reset Recovery Time	500	300		500	300		500	300		500	300		ps
t _{PW}	Minimum Pulse Width CLK, MR	400			400			400			400			ps
t _r , t _f	Rise/Fall Times (20% - 80%) Q0 - Q3 CL/4 & CL/8 SOUT	500 200 400	600 235 460	700 270 520	500 200 330	590 235 400	680 270 470	500 200 330	575 235 390	650 270 450	480 180 280	540 225 345	600 270 410	ps ps ps

- Notes: 1. For Standard ECL DC Specifications, refer to the ECL Logic Family Standard DC Specification Data Sheet.
 2. For part ordering description, see HPP Part Ordering Information Data Sheet.

HIGH-PERFORMANCE PRODUCTS

Application Information

The SK10/100E445 is an integrated 4-bit serial-to-parallel data converter. The chip is designed to work with the On Semi's E446 device to provide both transmission and receiving of a high speed serial data path. The E445 can convert up to a 2.0 GB/s NRZ data stream into 4-bit parallel data. The device also provides a divide by four clock output to be used to synchronize the parallel data with the rest of the system.

The E445 features multiplexed dual serial inputs to provide test loop capability when used in conjunction with the E446. Figure 1 illustrates the loop test architecture. The architecture allows for the electrical testing of the link without requiring actual transmission over the serial data path medium. The SINA serial input of the E445 has an extra buffer delay and should be used as the loopback serial input.

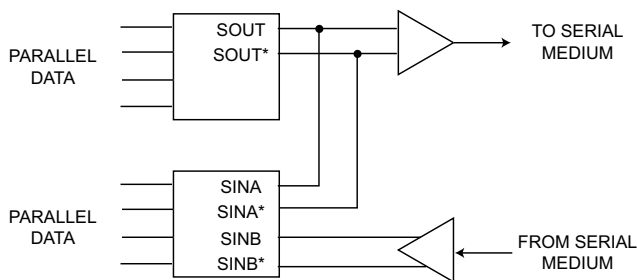

Figure 1. Loopback Test Architecture

The E445 features a differential serial output and a divide by 8 clock output to facilitate the cascading of two devices to build a 1:8 demultiplexer. Figure 2 illustrates the architecture for a 1:8 demultiplexer using two E445's; the timing diagram for this configuration can be found on the following page in Figure 5. Notice the serial outputs (SOUT) of the lower order converter feed the serial inputs of the higher order device. This feed-through of the serial inputs bounds the upper end of the frequency of operation. The clock to serial output propagation delay plus the setup time of the serial input pins must fit into a single clock period for the cascade architecture to function properly. Using the worst case values for these two parameters from the datasheet, TPD CLK to SOUT = 1150 ps and tS for SIN = -100 ps, yields a minimum period of 1050 ps

or a clock frequency of 950 MHz.

The clock frequency is significantly lower than that of a single converter. To increase this frequency, some games can be played with the clock input of the higher order E445. By delaying the clock feeding the second E445 relative to the clock of the first E445, the frequency of operation can be increased. The delay between the two clocks can be increased until the minimum delay of clock to serial out would potentially cause a serial bit to be swallowed (Figure 3).

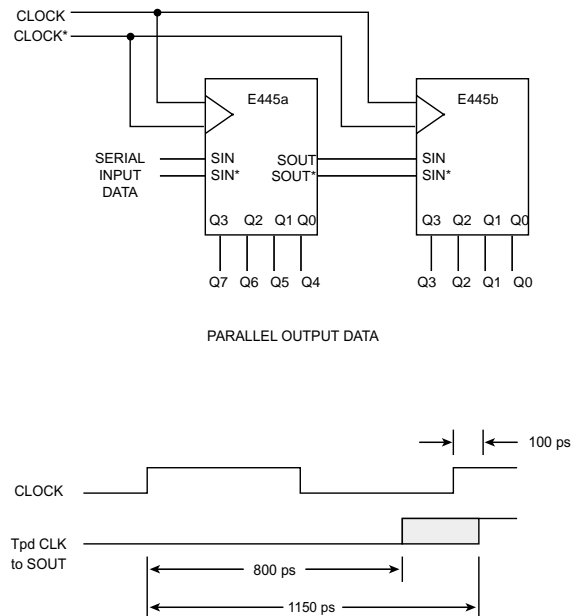

Figure 2. Cascaded 1:8 Converter Architecture

With a minimum delay of 800 ps on this output, the clock for the lower order E445 cannot be delayed more than 800 ps relative to the clock of the first E445 without potentially missing a bit of information. Because the setup time on the serial input pin is negative, coincident excursions on the data and clock inputs of the E445 will result in correct operation.

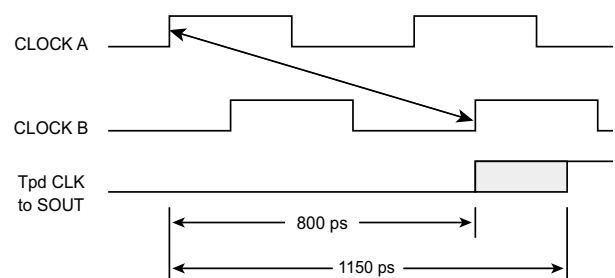

Figure 3. Cascade Frequency Limitation

HIGH-PERFORMANCE PRODUCTS
Application Information (continued)

Perhaps the easiest way to delay the second clock relative to the first is to take advantage of the differential clock inputs on the E445. By connecting the clock for the second E445 to the complimentary clock input pin, the device will clock a half a clock period after the first E445 (Figure 4). Utilizing this simple technique will raise the potential conversion frequency up to 1.4 GHz. The

divide by eight clock of the second E445 should be used to synchronize the parallel data to the rest of the system as the parallel data of the two E445's will no longer be synchronized. This skew problem between the outputs can be worked around as the parallel information will be static for eight more clock pulses.

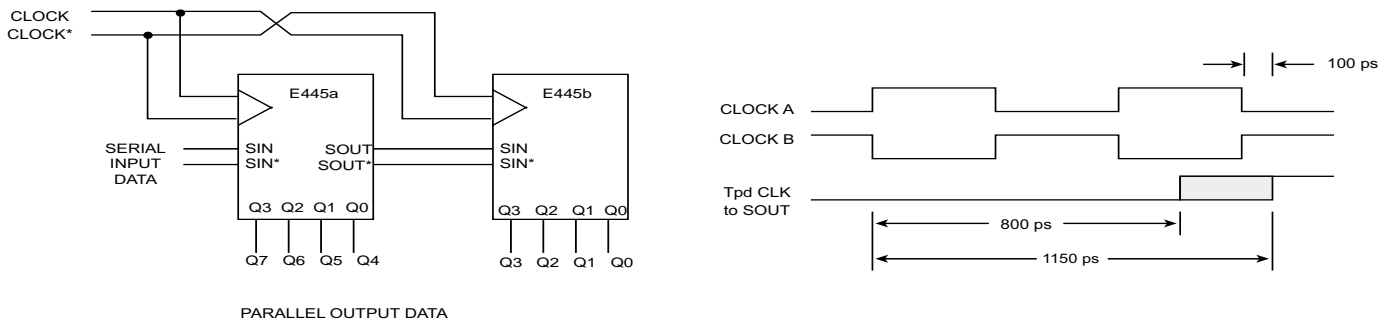

Figure 4. Extended Frequency 1:8 Demultiplexer

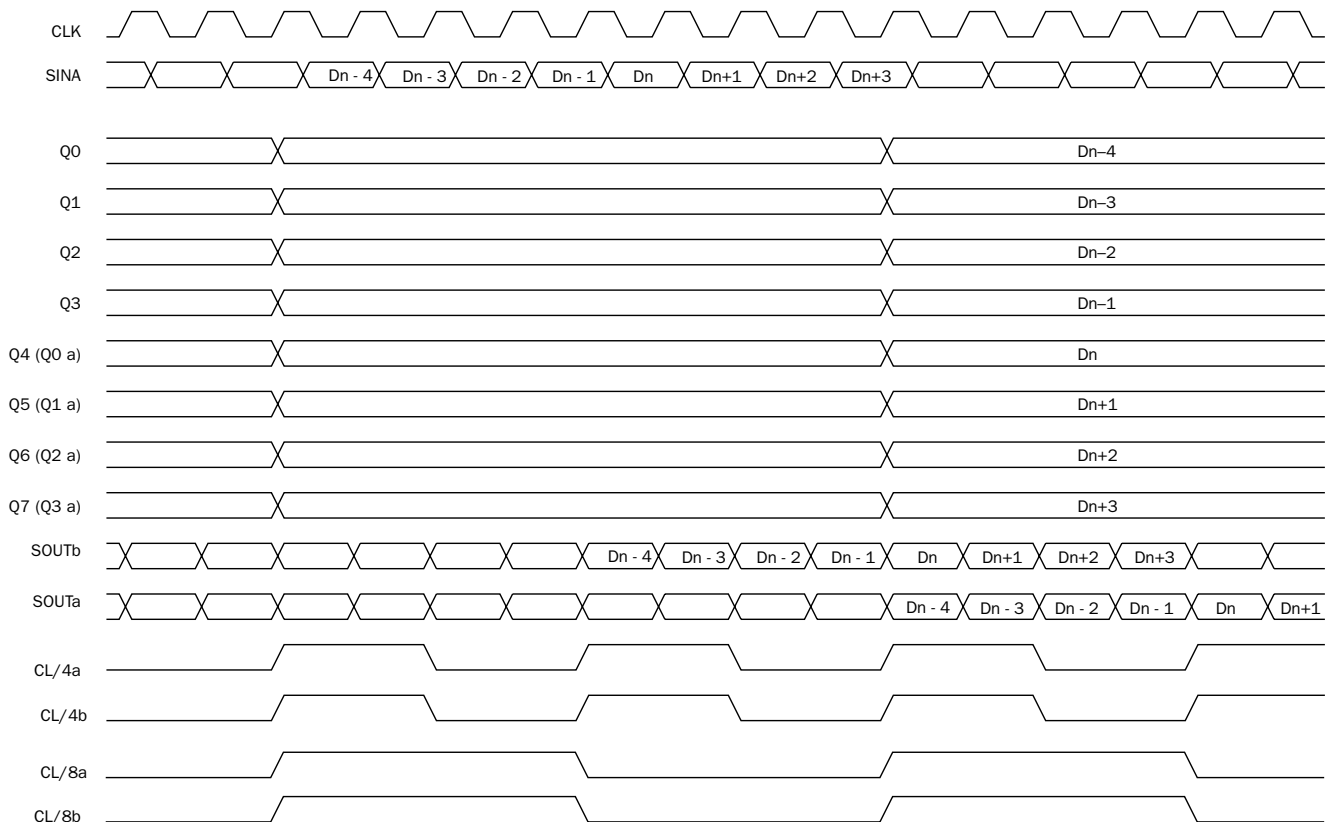

Figure 5. Timing Diagram A: 1:8 Serial to Parallel Conversion

HIGH-PERFORMANCE PRODUCTS**Ordering Information**

Ordering Code	Package ID
SK10E445PJ	28-PLCC
SK10E445PJT	28-PLCC
SK100E445PJ	28-PLCC
SK100E445PJT	28-PLCC

Contact Information

Division Headquarters
10021 Willow Creek Road
San Diego, CA 92131
Phone: (858) 695-1808
FAX: (858) 695-2633

Semtech Corporation
High-Performance Products Division

Marketing Group
1111 Comstock Street
Santa Clara, CA 95054
Phone: (408) 566-8776
FAX: (408) 566-8759